

MDO_00	K4	DDR3_D00	
MDO_01	M3	DDR3_D01	
MDO_02	J4	DDR3_D02	
MDO_03	N4	DDR3_D03	
MDO_04	K3	DDR3_D04	
MDO_05	N3	DDR3_D05	
MDO_06	G3	DDR3_D06	
MDO_07	L3	DDR3_D07	
MDO_08	H3	DDR3_D08	
MDO_09	J5	nDDR3_D09	
MDO_10	M4		DDR3_DM0
MDO_11			
MDO_12			
MDO_13	J2	DDR3_D014	
MDO_14	M1	DDR3_D015	
MDO_15	J1	DDR3_D016	
MDO_16	K1	nDDR3_DQ31	
MDO_17	L2		DDR3_DM1
MDO_18			
MDO_19			
MDO_20	R4	DDR3_D016	
MDO_21	V4	DDR3_D017	
MDO_22	R3	DDR3_D018	
MDO_23	W4	DDR3_D019	
MDO_24	T4	DDR3_D020	
MDO_25	Y2	DDR3_D021	
MDO_26	P3	DDR3_D022	
MDO_27	V3	DDR3_D023	
MDO_28	T3	DDR3_D024	
MDO_29	U3	nDDR3_DQ32	
MDO_30	W3		DDR3_DM2
MDO_31			
MDO_32			
MDO_33	R2	DDR3_D024	
MDO_34	V2	DDR3_D025	
MDO_35	P1	DDR3_D026	
MDO_36	W1	DDR3_D027	
MDO_37	R1	DDR3_D028	
MDO_38	Y1	DDR3_D029	
MDO_39	P2	DDR3_D030	
MDO_40	U2	DDR3_D031	
MDO_41	T1	DDR3_D033	
MDO_42	U1	nDDR3_DQ33	
MDO_43	V1		DDR3_DM3
MDO_44			
MDO_45			
MDO_46			
MDO_47			
MDO_48			
MDO_49			
MDO_50			
MDO_51			
MDO_52			
MDO_53			
MDO_54			
MDO_55			
MDO_56			
MDO_57			
MDO_58			
MDO_59			
MDO_60			
MDO_61			
MDO_62			
MDO_63			
MDO_64			
MDO_65			
MDO_66			
MDO_67			
MDO_68			
MDO_69			
MDO_70			
MDO_71			
MDO_72			
MDO_73			
MDO_74			
MDO_75			
MDO_76			
MDO_77			
MDO_78			
MDO_79			
MDO_80			
MDO_81			
MDO_82			
MDO_83			
MDO_84			
MDO_85			
MDO_86			
MDO_87			
MDO_88			
MDO_89			
MDO_90			
MDO_91			
MDO_92			
MDO_93			
MDO_94			
MDO_95			
MDO_96			
MDO_97			
MDO_98			
MDO_99			
MDO_100			

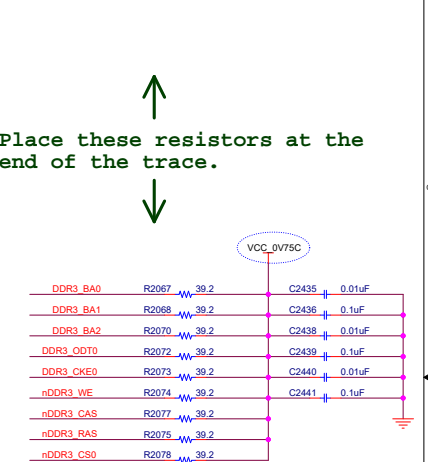

\* Data bits can be swapped within the byte lane to ease routing.  
\* Address/Command/Clock routing must be Fly-By in byte order 0, 1, 2, 3 ECC, 4, 5, 6, 7.

Place these resistors at the end of the trace.

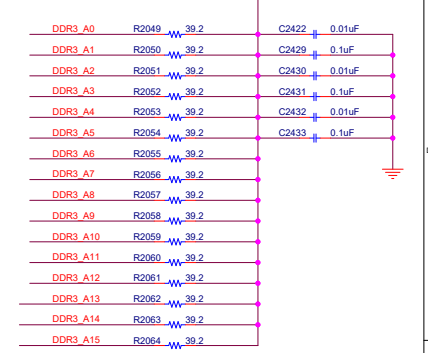
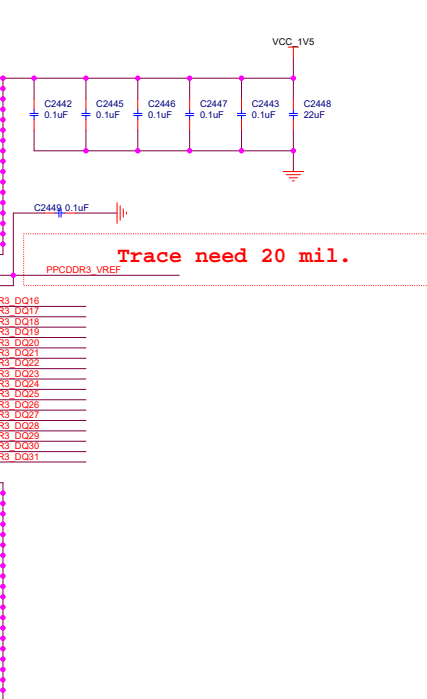
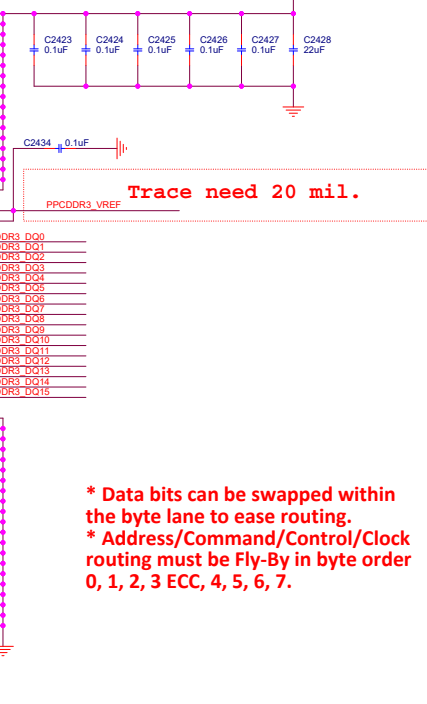
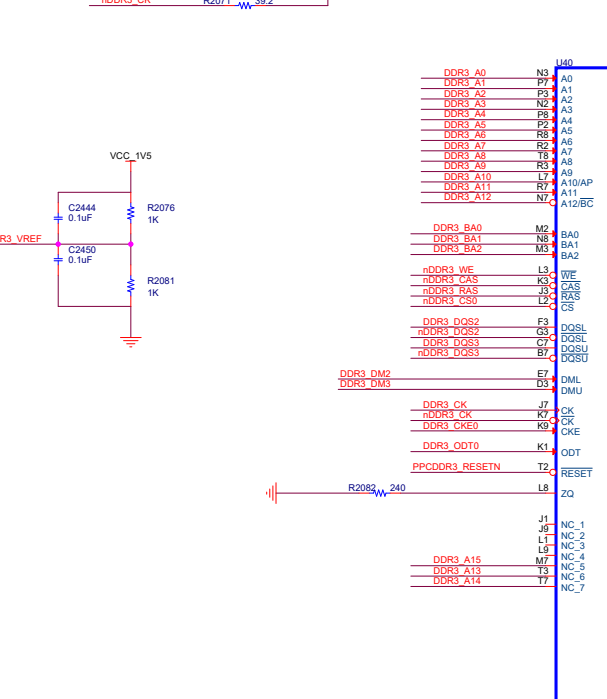
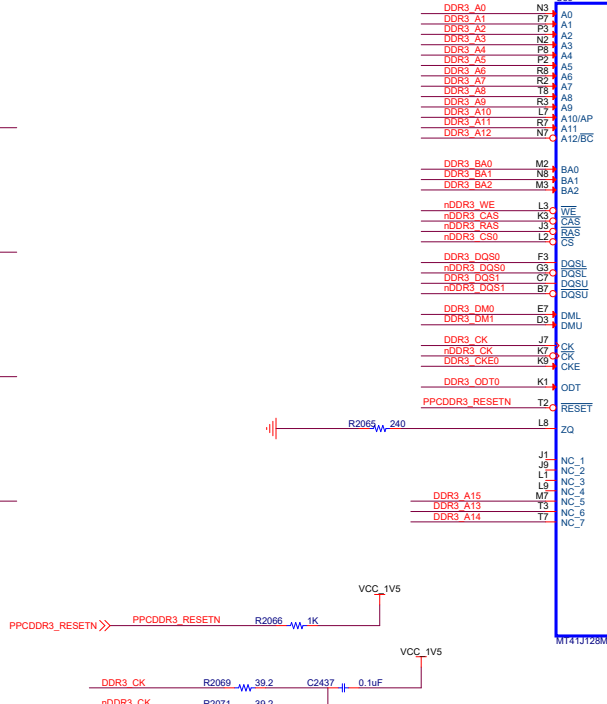
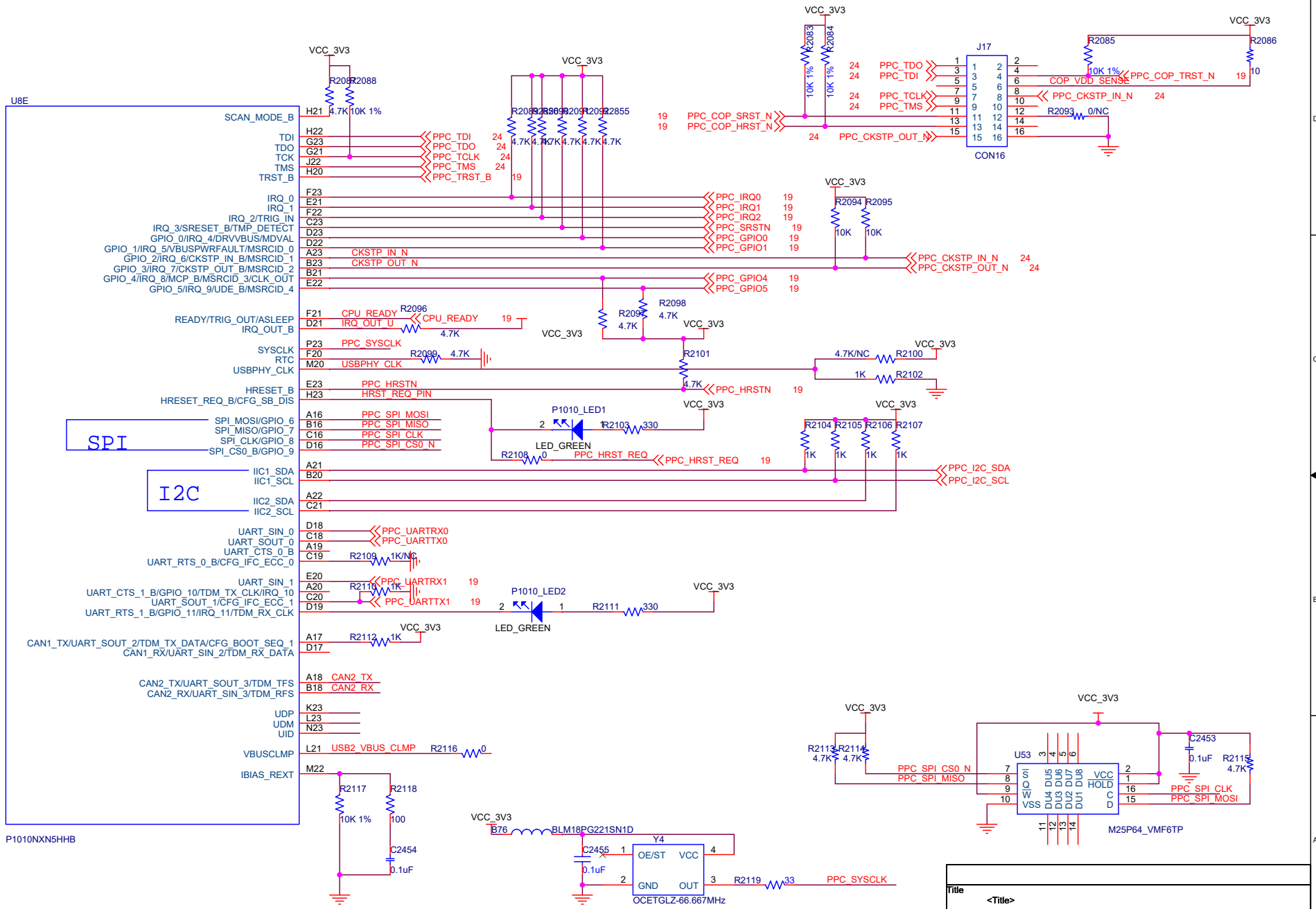

Title		<Title>
Size	Document Number	Rev
B	<Doc>	<RevCode>
Date:	Monday, April 18, 2016	Sheet 24 of 40

U8B

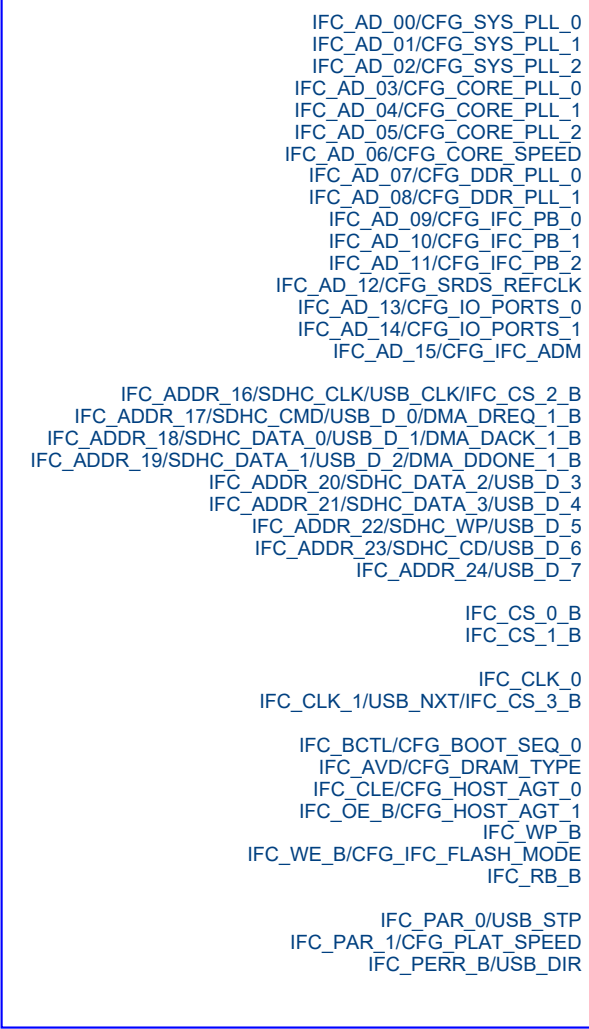

P1010NXN5HHB

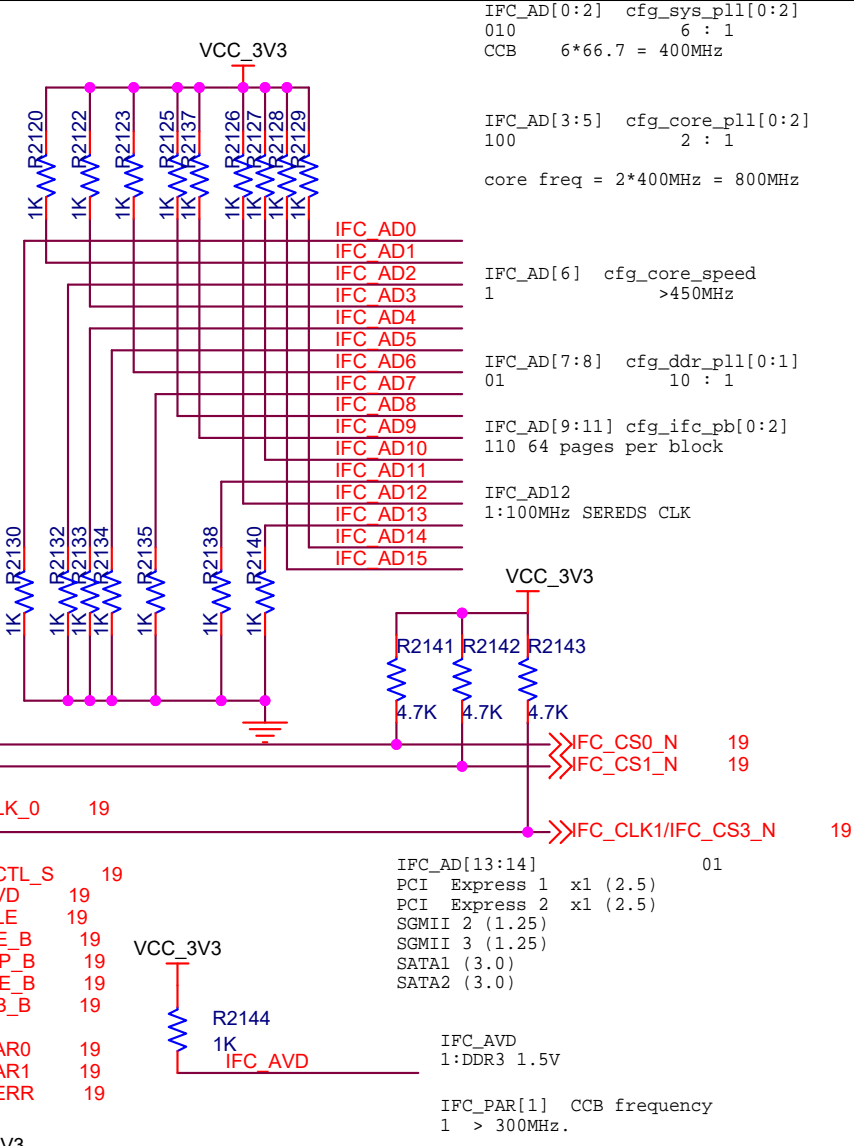
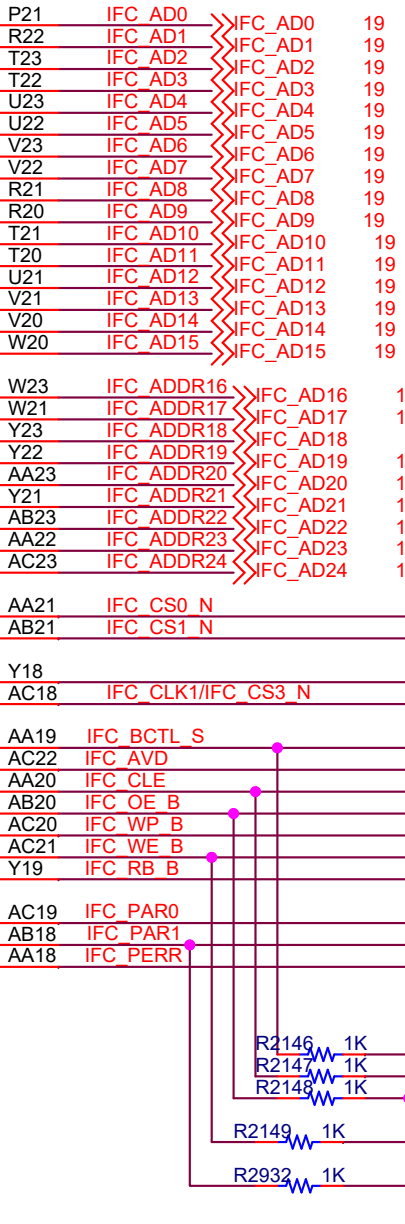

PCIE0,1 : root complex mode

Title		
<Title>		
Size	Document Number	Rev
A	<Doc>	<RevCode>
Date:	Monday, April 18, 2016	Sheet 25 of 40



