



Analog and Sensor Overview

For Industrial Applications

Stephen Yan 闫子波 | Analog & Sensor Group

M A Y . 2 0 1 5



External Use

Freescale, the Freescale logo, AN/Vec, C-5, CodeTEST, CodeWarrior, ColdFire, ColdFire+, C-Ware, the Energy Efficient Solutions logo, Kinetic, MagniV, mobileGT, PEG, PowerQUICC, Prosecc Expert, QorIQ, QorIQ Qonvergence, Qorivos, Ready Plus, SafeAssure, the SafeAssure logo, StarCore, Synchrify, Vortiga, Vybrid and Xilinx are trademarks of Freescale Semiconductor, Inc., Reg. U.S. Pat. & Tm. Off. AirMat, BeeKit, BeeStack, CoreNet, Flexis, LayerStack, MAXC, Platform in a Package, QUICC Engine, SMARTMO25, Tower, TurboLink and UMEMS are trademarks of Freescale Semiconductor, Inc. All other product or service names are the property of their respective owners. © 2015 Freescale Semiconductor, Inc.



We Are a Global Leader in Embedded Processing Solutions

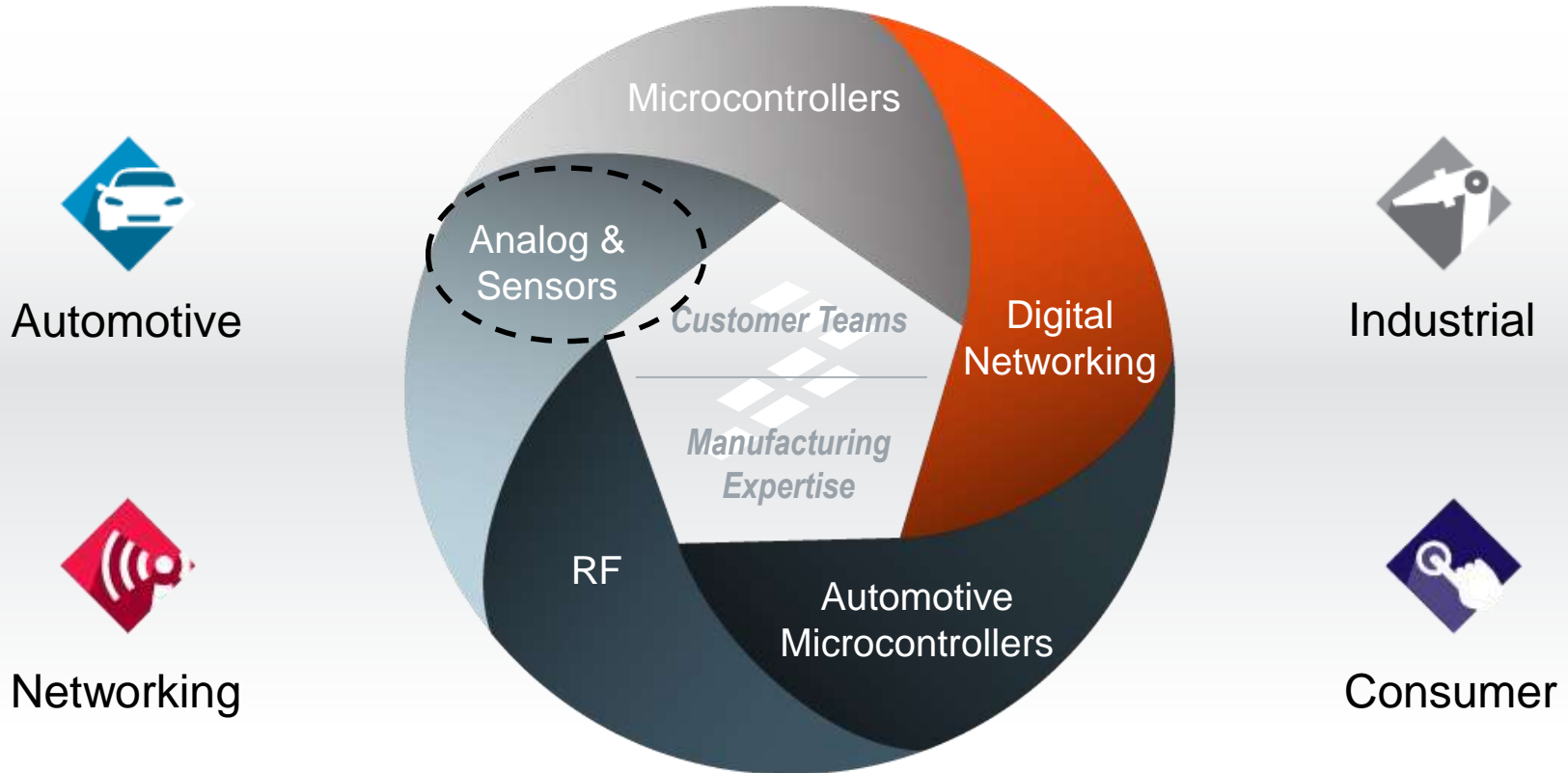

Five Core Product Groups

>50 Year Legacy
>6,000 Patent Families*

Four Primary Markets



Analog and Sensors

Making Embedded Systems Real

#2 merchant auto MEMS
#3 inertial + pressure MEMS
#4 merchant auto analog



Complete Embedded
System Solutions +
Automation

Preferred MCU partner
Bridges real-world to digital
Turnkey reference designs



Differentiated
Robust, Reliable
Performance

Thermal and energy efficient
Precision sense and control
Extreme harsh environments



Leadership in
Functional Safety

30+ years auto experience
Health monitoring and failover
Revolutionized “Safe” systems



Analog Portfolio

Bridging Real-World Physics to Connected Digital Intelligence



System Power Management and Interface



Power Drivers and Switches



Battery Management



Analog System Solution

Power Management IC

System Basis Chip

Physical Layer Transceiver

Input Monitoring

LDO – DC/DC
Safety – Monitoring
CAN – LIN – TPL – DSI

Gate Driver

Power Driver

eXtreme Switch

Low $R_{DS(on)}$ – SPI
High Side – Low Side
Diag. & Protection

Intelligent Battery Sensor

Battery Cell Controller

Li-Ion Battery Charger

Alternator Regulator

System in Package
800V – Balancing
LIN – CAN – TPL

77 GHz Radar

Airbag

Valve Controller

Programmable Solenoid Controller

Small Engine Controller

System On Chip
Safety
Diag. & Protection

System Power Management Solutions

Mission: One PMIC for each Freescale processor sold and more

 <p>freescale S32</p>	 <p>freescale i.MX</p>	 <p>freescale QorIQ</p>	 <p>freescale Kinetis</p>
<p>SBC's with Functional Safety</p>	<p>PMICs</p>	<p>High Performance Regulators</p>	<p>Battery Chargers</p>
			

Freescale PMICs for i.MX & QorIQ Processors

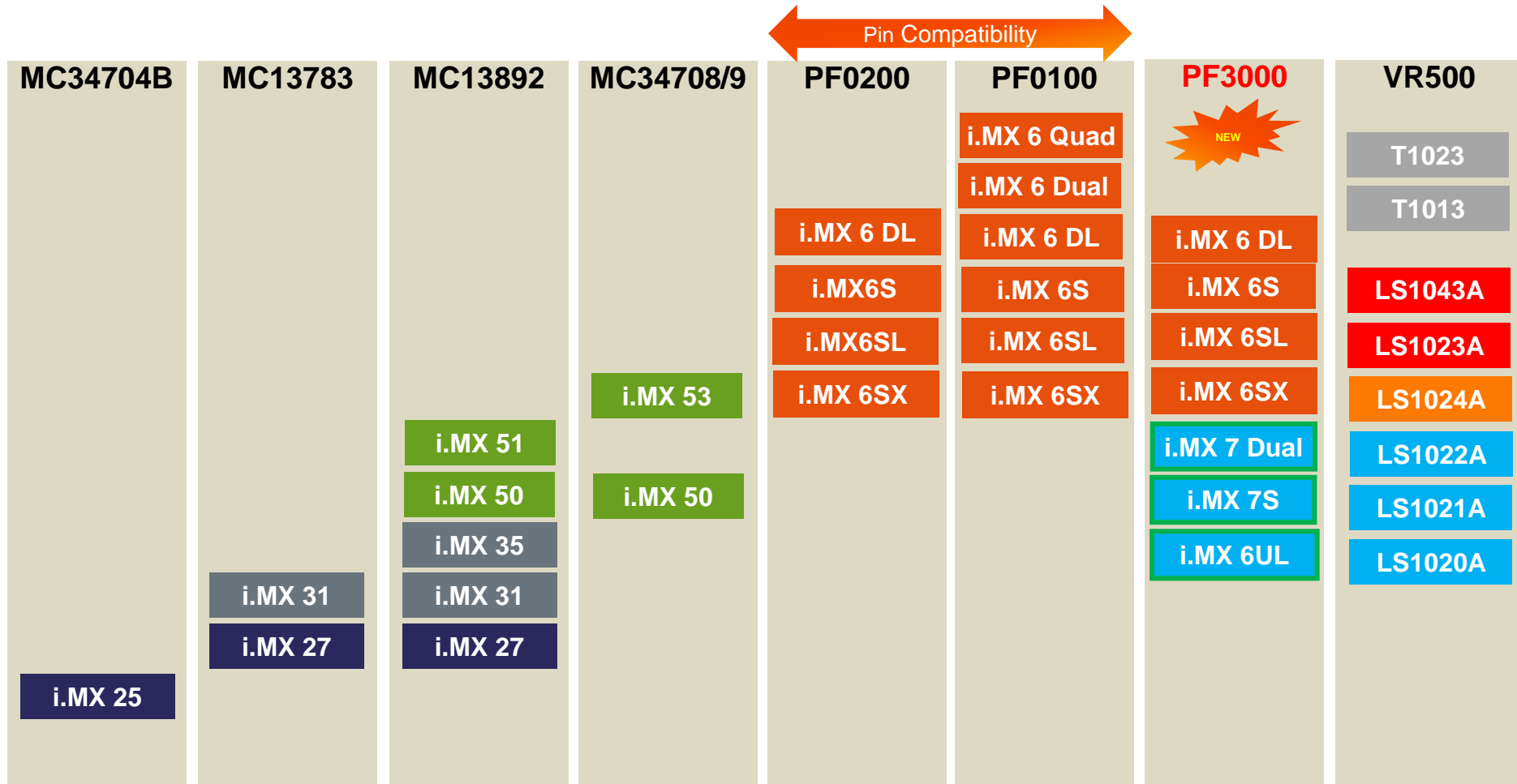

ARM11

ARM9

Cortex-A8

Cortex-A9

Cortex-A7

New MCU



Example: PF0100 Power to Complete i.MX 6 System

System Power Fusion by Freescale™

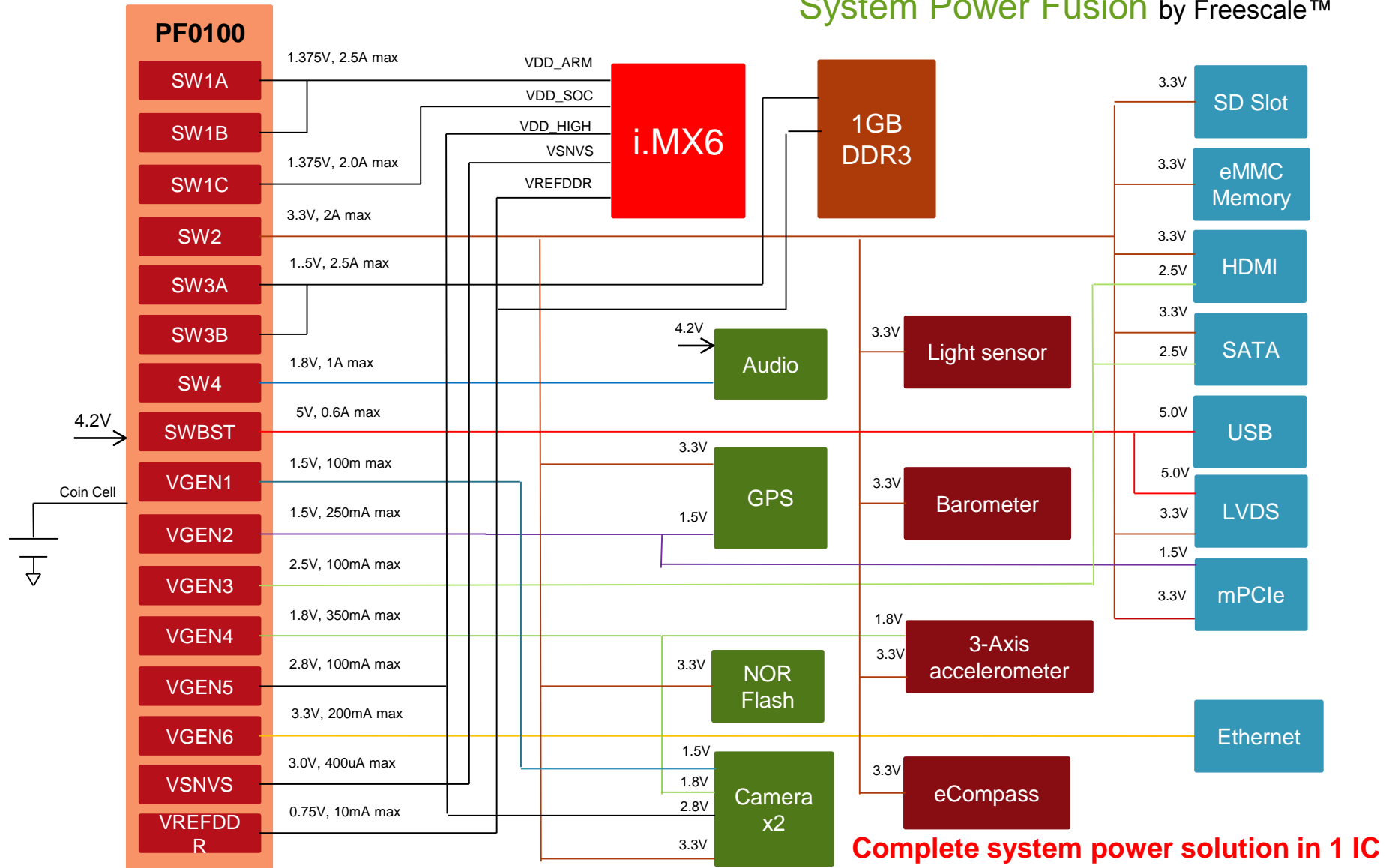

Complete system power solution in 1 IC

MMPF0200 : 12 Channel Configurable PMIC

Differentiating Points

- Compatibility with i.MX6 DL, S, SL, SX processors. BSPs under validation (patch released at the end of June).
- Boost regulator to 5.0 V out for USB
- OTP (One Time Programmable) memory to configure the start sequencing
- Custom pre-programmed output voltages, sequencing, and timing available
- Power control logic with processor interface and event detection

Product Features

- Vin 2.8V to 4.5V Supply
- 3 to 4 Channel configurable buck converters
- 6 User programmable LDO
- Forced PWM or automatic operation
- Boost regulator, Coin cell charger, DDR reference
- Programmable output voltage, current limit, soft-start, Fsw, OTP fault interrupt
- High power 8x8 mm, 56 E-QFN or WF-QFN

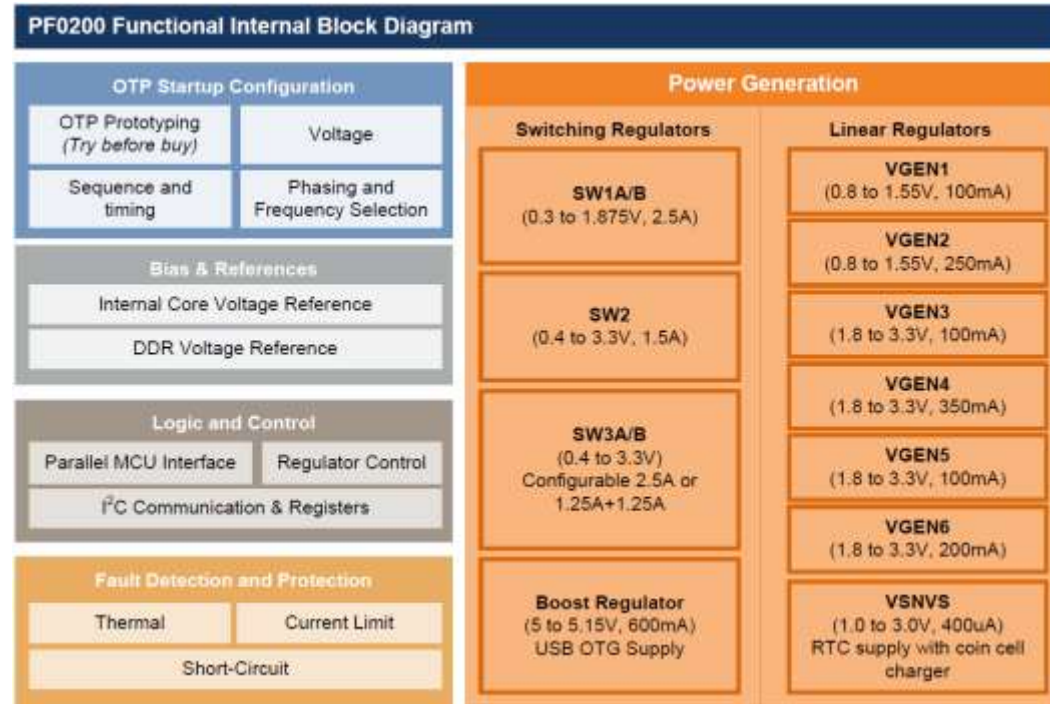

Lower featured version of the PF0100. SW1C and SW4 regulators are removed in MMPF0200 and SW2's current rating is reduced to 1.5A

Applications

- Tablets, eReaders, Smartbooks, Navigation
- IPTV, IP Phone
- Automotive infotainment
- Human-machine interface, Home Automation
- Portable Medical



Why Customer will buy Freescale's PMIC



Simplified Complexity

- **PMICs are defined alongside MCU development team**
 - Insure full **compatibility** with dedicated MPU/MCU's
- **Proven Solutions**
 - Complete **reference** designs with Android and Linux drivers
 - Development kits (SABRE, RIOT and more) for quick implementation
 - **From Freescale proven partner**
- **Highly Configurable with preprogrammed version**
 - Insure **Scalability** among i.MX family support
 - Factory preprogrammed version for specific i.MX

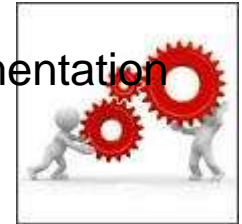

Energy Efficiency

- **The best light load efficiency on the market**
 - ~90% efficiency across the entire current delivery range
- **Dynamic Voltage Scaling** for power consumption optimization
- Soft Start Sequencing options for voltage rail start up
- **Best In Class Quiescent current for wearable series**



Functional Safety In Industrial

Key Applications

- **Transportation** Systems
- **Energy Conversion & Distribution (Inverters & Battery Management Safety Critical)**
- **Motor Control** Safety Critical (Robotics)
- Factory & Building **Automation**

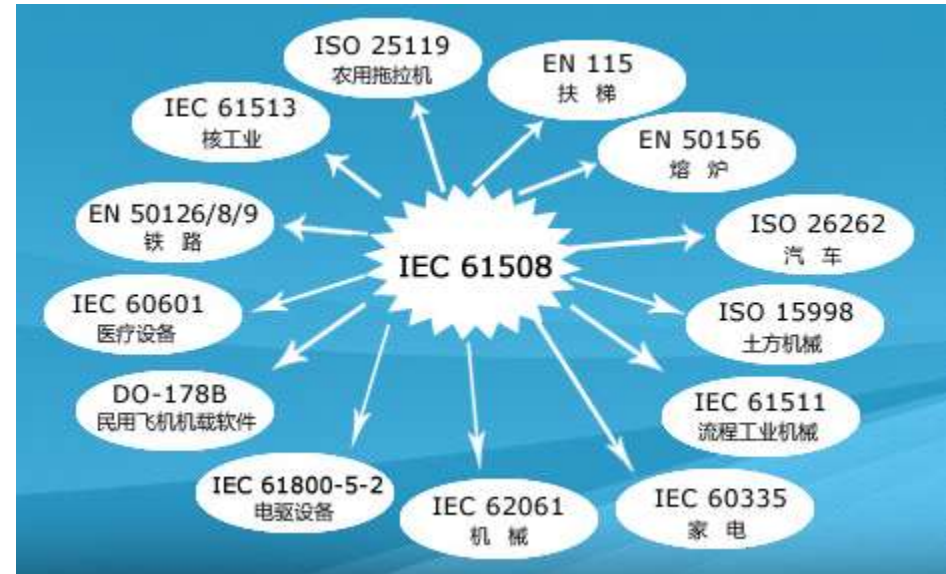

MC34FS6407 and FS6408 – SBC Key Features

Differentiating Points

- **Availability** : wide voltage operation range from 2.7V to 36V
- **Efficiency** of a Dual DC/DC converter topology
- **Safety** : Innovative architecture allowing **independent** monitoring of safety critical parameters
- **Scalable** family of products supporting a wide range of MCU and power segmentation architectures

Product Features

- **Bundles with** MCUs below 4 W of power dissipation
- Flexible DC/DC Buck pre regulator with optional Boost to fit with **Low Voltage requirements**
- Multiple supplies up to 1.5 A (up to 36 V operating voltage)
- Low Power Modes (**30 μ A**)
- Analog Multiplexer & Battery sensing
- **Independent fail safe state machine** supporting functional safety standards
- Secure SPI interface
- Robust CAN physical layer with superior EMI/ESD performance
- LQFP48 with Exposed Pad (7 x 7mm)

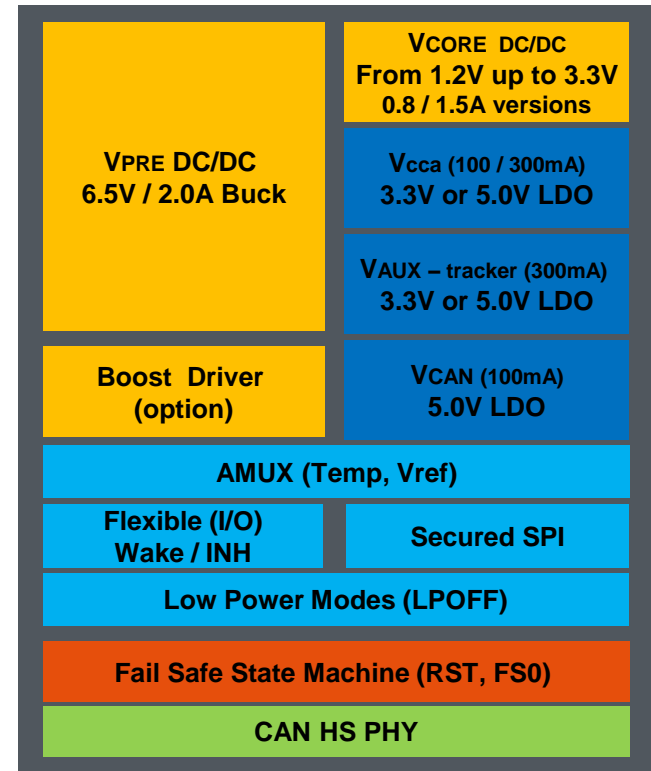

Applications

- Automation (Safe PLC, Robotics)
- Building control (Elevator, Gas furnace)
- Transportation (Mobile machine, Military)
- Medical (Infusion pump, monitoring)

Samples Available

Qualification March 2015



Interface and Input Monitoring



CAN Transceiver Market Dynamics

Energy Efficiency



- Minimize Standby Current without impact on Transceiver immunity
- CAN Partial Networking for energy savings – new ISO standard 11898-6 for CAN selective wake up

Functional Robustness



- EMC and ESD standardization
- Exceed EMC performance without common mode choke
- Improved safety and predictable behavior to secure communication

Increased Bandwidth



- Reduce SW download duration
- Increased Intersystem data exchanges require higher bandwidth
- CAN FD to increase bandwidth with limited architecture changes

Simplified Complexity



- Enhanced ESD protection to lower cost and improve quality
- Standard solutions with enhanced performance
- External lab certifications

MC33901/34901 **Chokeless** CAN High Speed Physical Layer

Differentiating Points

- **High Robustness:**
 - Exceeds EMC & ESD requirements **without added choke**
 - EMI compliant with **CAN FD 2M w choke**
- **Designed for EMC:** Low emission design combined with high immunity performance
- **Lowest quiescent current**, down to 8 μ A
- **Automotive and Industrial-Ready** : Specific P/N to support long-length CAN node interconnect



Product Features

- **Pin-to-pin compatible with standard**
- 5V and 3.3V I/O compatibility with auto-detection
- Industry-specific product options:
 - **Automotive:** Built-in “Tx Dominant Timeout” feature (MC33901)
 - **Industrial:** Built-in support for long-length and low baud rate networks (MC34901)

	Auto	Industrial
Wake Up	MC33901W	MC34901W
Standard	MC33901S	MC34901S
Mass Production		



CM0902 Dual CAN High Speed Transceiver

Robust, system-cost effective CAN High Speed Physical Layer offering low quiescent current while exceeding stringent EMC/ESD requirements, without added circuitry

Differentiating Points

- **System Performance/Cost:** 500kbit/sec EMC compliant w/o Common Mode Choke
- **Scalable System Solution:** Seamless attach to Freescale MCUs
- **Robustness:** Automotive OEM certified (MC33CM0902)

Product Features

- Pinout and function compatible w/CAN ISO11898-2 and -5 standard products
- I/O (SPI) is compatible with both 5V and 3.3V MCU digital levels
- Vdd and IO voltage monitoring, ability to respond in 'fail-safe' manner
- Low power modes and wake up capability
- 15uA quiescent current in low power mode
- Robustness:
 - **ESD without choke** : +6kV ESD contact discharge according to IEC61000-4-2, 150pF-330ohms
 - **Noise Immunity without choke** : Meet 36dBm DPI without external protection and 39dBm DPI with additional capacitors
 - Bus pins protected against Automotive Transients
- Automotive (AEC-Q100) and Industrial versions available
 - Automotive: MC33CM0902 (Tx Dominant Timeout)
 - Industrial: MC34CM0902 (No Timeout - Low baud rate applications)
- SOIC-14 and DFN14eP (planned)

MCU

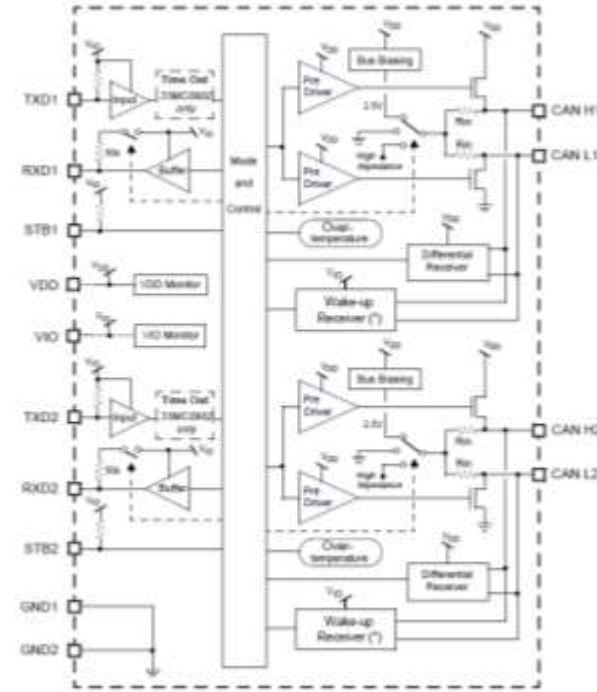

Typical Applications

- Auto Powertrain & Safety
- Motor control - Safety Critical
- Robotics
- Factory Automation



Main Differentiators

- Data rate, support both high data rate and low data rate in long distance
 - Competitors: minimum data rate >40kbps
 - Freescale: MC33901 ≥ 5 Kbps
- EMC performance
 - Freescale: Chokeless for 1Mbps, 2Mbps with Choke
- ESD performance
 - +/-8kV for contact discharge
- High impedance in un-power node
 - support hot plug-in/out

PLC product examples (Siemens, Rockwell)

Smart Relay



Siemens LOGO!



Rockwell Pico (Allen Bradley)

Compact PLC



Siemens SIMATIC S7-200



Rockwell MicroLogix

Standard Modular PLC



Siemens SIMATIC S7-300



Rockwell CompactLogix

High-End Modular PLC

Siemens SIMATIC S7-400



Rockwell ControlLogix

PLC I/O

- **DI** (Digital Inputs) – Sense external switches

CIO
MC33972/5/8

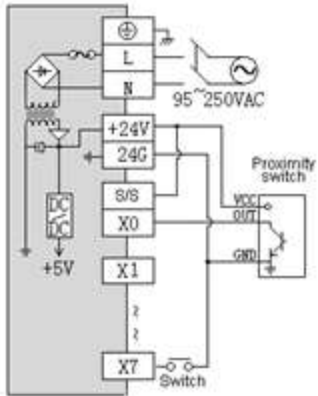

NPN Internal power

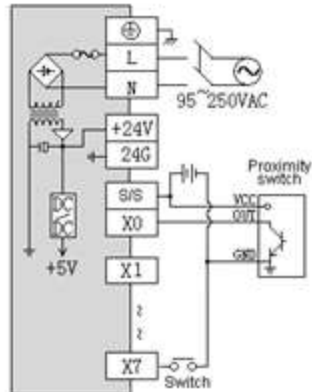

NPN External power

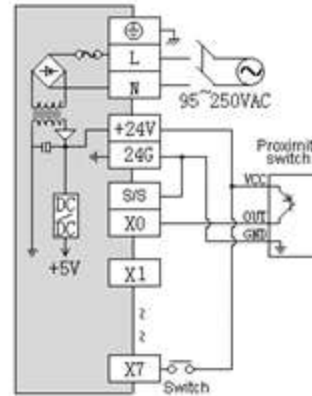

PNP Internal power

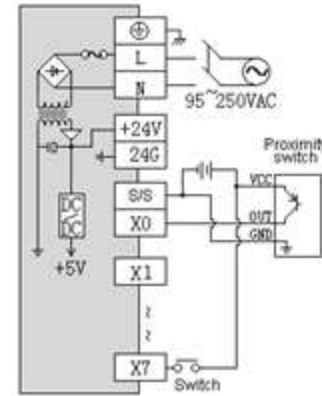

PNP External power

- **DO** (Digital Outputs) – Drive Relay/Valve/LED etc.

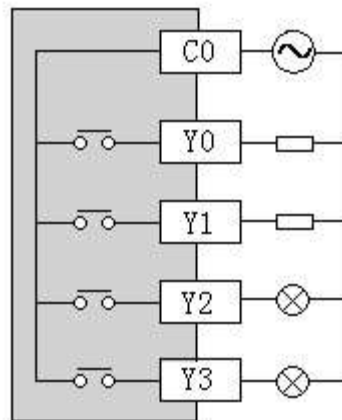

External Us

AC/DC Relay output

Lowside/high side switch
MC33999
MC33882
MC33879A

MC33999 - 16 Output Switch with SPI and PWM Control

Key Features

- RDS(ON) @ 25 degree C 0.55 Ohm
- Operating Voltage, VPWR 5.0 V – 27 V
- Operating Voltage, SOPWR 3.1 V – 5.5 V
- Outputs current limited (0.9 A) and voltage clamped (50V) for switching incandescent and inductive loads
- Output independent over temperature shutdown
- Programmed PWM of any combination of outputs plus parallel
- input control of eight outputs
- Output ON short-to-VBAT and OFF short-to-ground/open detection
- OFF open load detection current can be disabled for sensitive LED applications
- SPI diagnostic reporting

Applications

- PLC
- Valve control
- Medical Applications

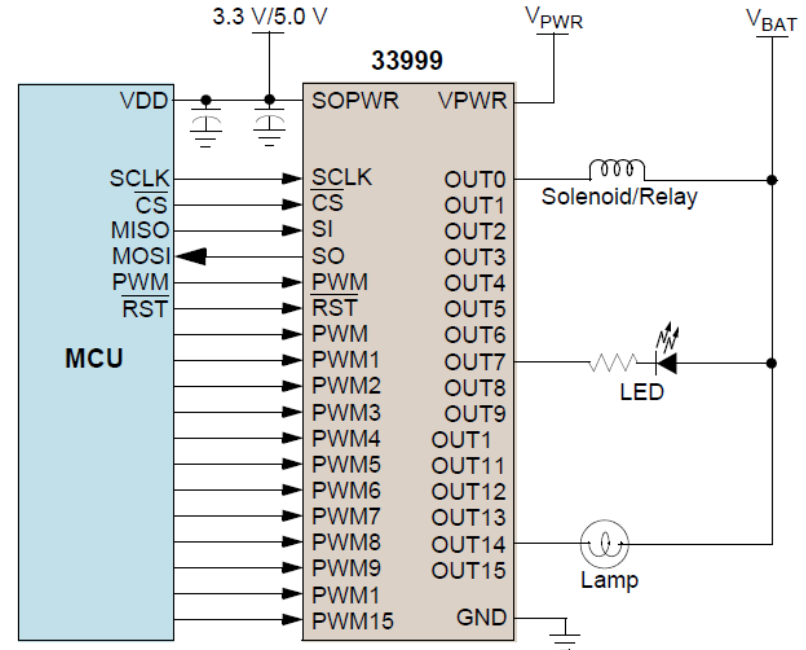

0.65 mm Pitch
7.5 mm x 17.9 mm Body
4.6 mm x 4.6 mm Expose ad

C I/O - What is it?

Multi-function input/output IC that can be used as...

- An input signal conditioning IC with specialized features for monitoring switch contacts
- A device to wake up the system from a reduced power state based on several conditions
- An analog multiplexer
- A source of external sensor switched power
- An output device for driving LEDs and FETs
- Any combination of the above!

For low pin count MCUs it provides an efficient means to expand system I/O capabilities

For all systems, it can replace numerous ICs, discretes, and passives, greatly reducing board space



Features

- Automatically detects switch opening and closing
 - Up to 22 switch contacts
- 14 pins detect switch closures to ground
- 8 pins are programmable to
 - Detect either switch closures to ground or to power
- Wide switch input voltage range
 - -14 to VPWR, (40V Max)
- Wetting current to minimize contact corrosion
 - Selectable 16 mA or 2 mA
- Serial interface to controller or processor
 - Uses popular SPI protocol
 - Directly connects to either 3.3 or 5.0V SPI ports
- Robust inputs
 - 4.0 V ground offset protection
 - 5.5 to 26 volt operation



MC3x978 Configurable IO MC33978 (Automotive) MC34978 (Industrial)

Analog Multiple Switch Detect Interface for translating 22 IOs onto a single MCU SPI bus with configurable wetting/drive current and low power auto-wake modes

Differentiating Points

- Proven performance & robust IO ESD above 15kV for gun stress test
- Quiescent current of 30uA; < 1/2 that of competitors and 1/100th that of discrete solutions
- Operating voltage range: 4.5V-36V to meet auto load dump
 - 48% better than competition
- 5*5mm QFN coming, compared to 6*6mm for competition
- Integrated battery sense

Product Features

- 22 I/Os:
 - 14 switch-to-ground
 - 8 programmable - switch to battery or ground
- 24-1 analog multiplexer
- -14 to +40V switch input voltage range
- Programmable wetting/drive current from 2mA to 20mA
 - Current Source capable of driving white LEDs
- SPI Interface with enhanced register set
- Wake-up upon signal detection
- Integrated temperature sensor and Battery Voltage Sensing
- -40c to 125c temperature range

Preliminary Schedule

- Initial Samples/Prelim Datasheet: Available Now
- Final Samples/Begin Qualification: Nov '14
- Qualified Samples/Launch: 1Q '15

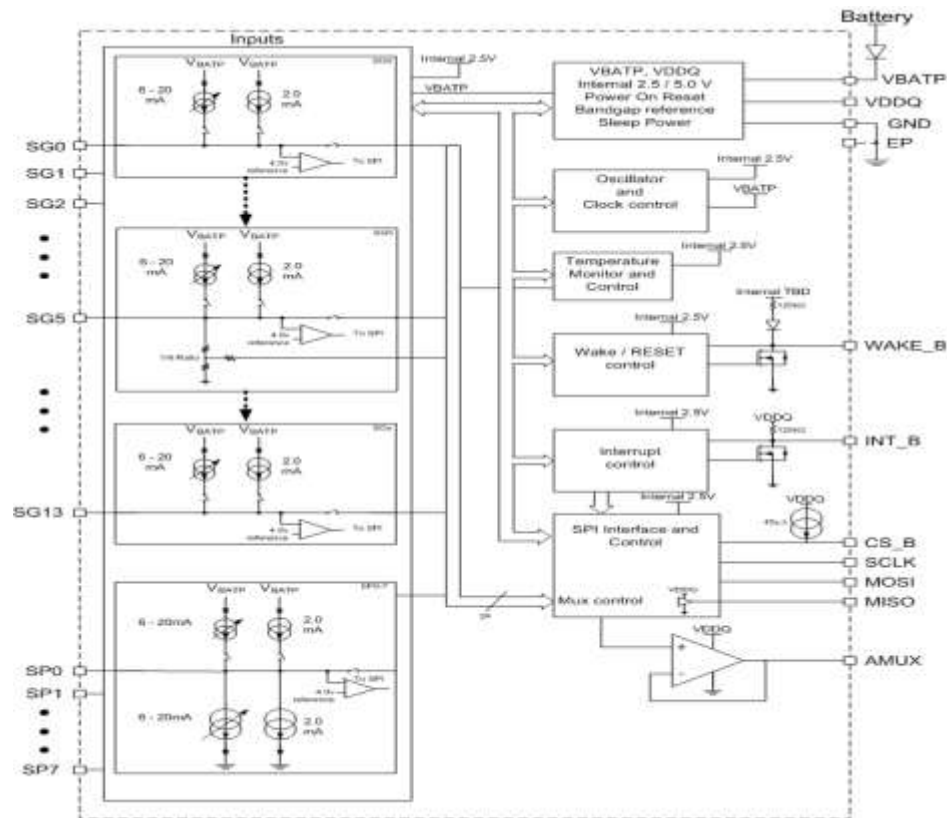

Applications

- Multiple switch detect in Body-Control modules
- Engine Control Modules
- Front-of-Dash Modules
- Wire Harness
- Junction Box
- White Goods



EK SUFFIX (PB-FREE)
98ASA10556D
32-PIN SOICW-EP



ES SUFFIX (PB-FREE)
98ASA00656D
32-PIN QFN (WF-TYPE)



MC33978 with 22 digital input channels

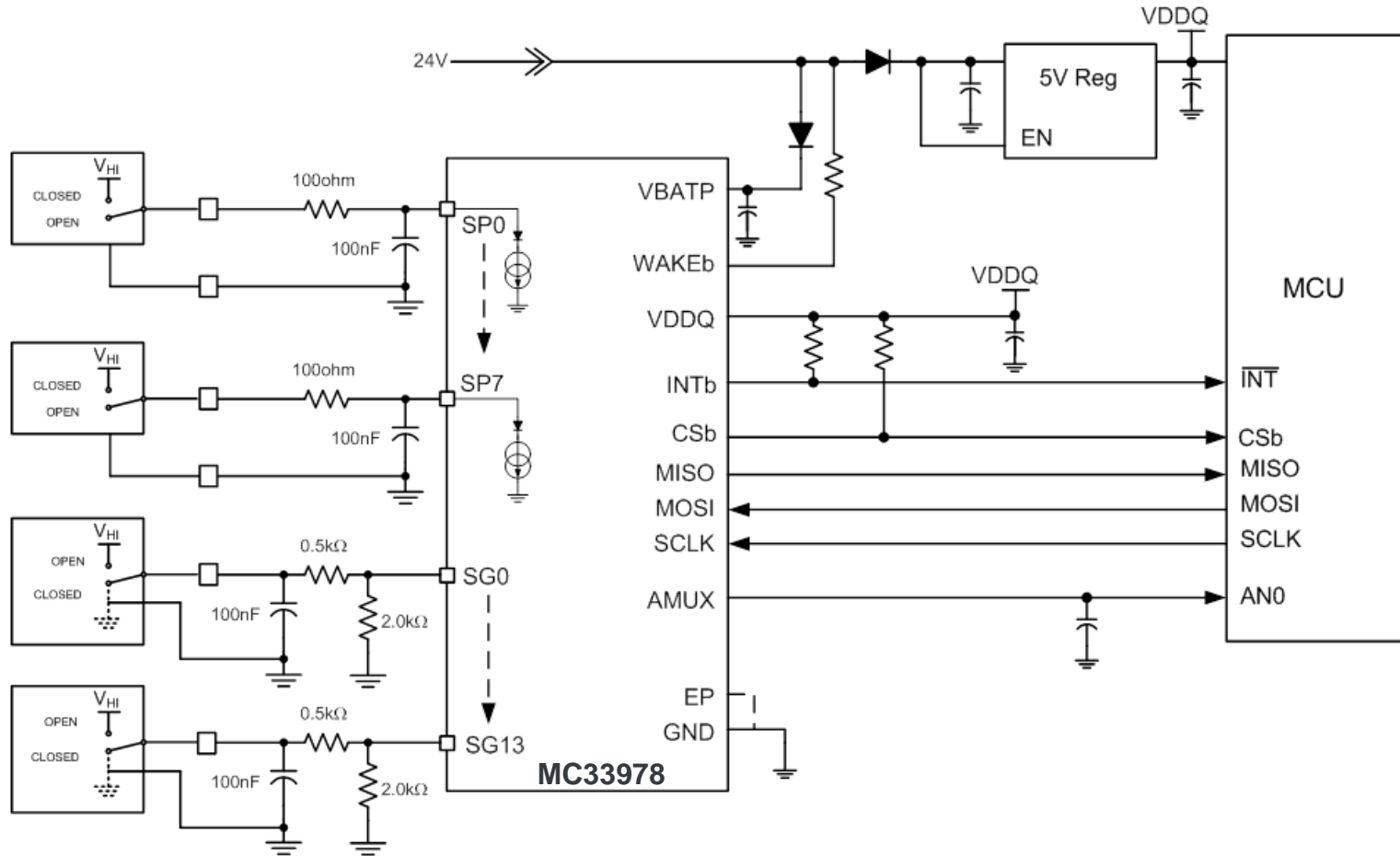

Analog Solutions for PLC

System Basis Chip

- Up to 36V input regulators for **MCU** and peripherals
- Functional Safety support features
- CAN Physical layer integrated

Configurable Power Management IC

- Voltage regulators for **MPU**, memory and peripherals
- Programmable voltage levels and timings (up to 14)
- MMPF series for i.MX, MC34VR500 for LS1

CAN Transceiver

- High EMC and ESD performance, enables choke protection removal
- TXD dominant time out disabled enables low baud rate & long cables

Configurable Octal Switch

- 8 configurable high side or low side switches with SPI interface
- RDS(ON) of 750 mΩ at 25 °C

Low RDSon High Side Switch

- Integrated control with high number of protective and diagnostic functions
- 6 to 50 mΩ RDSon

Multiple Input Monitoring Device

- Monitor up to 22 switch contacts with current wetting; or LED driving capability
- Multiplexed analog input
- Enables lower system stand-by current

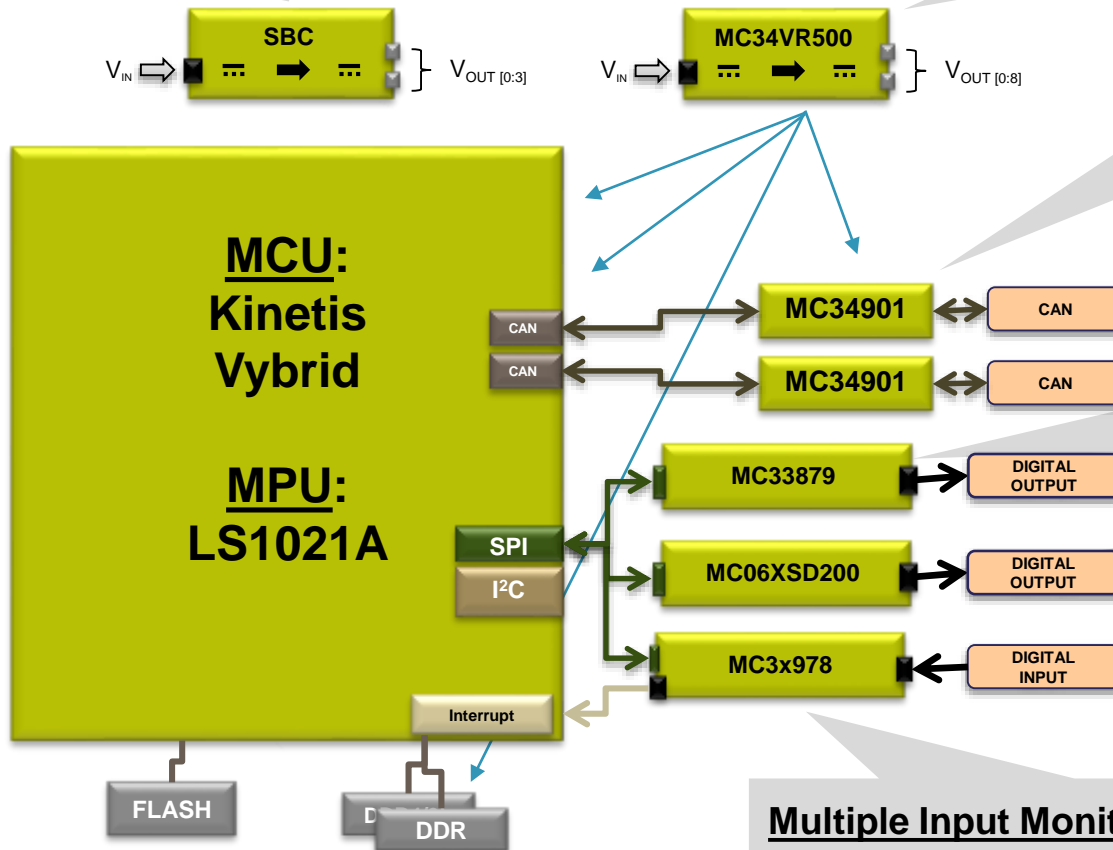



24 A / 36 V eXtreme Switch

MC06XSD200 – MC10XSD200 – MC16XSD200 – MC22XSD200 – MC50XSD200
Dual 6mΩ Dual 10mΩ Dual 16mΩ Dual 22mΩ Dual 50mΩ

Scalable, programmable family of 24 A/36 V SPI-driven, dual-channel, smart high-side switches with lowest RDSon for up to a 30% board reduction

Differentiating Points

- **Robustness:** Unique over-current latch-off protection, full digital & analog diagnostic and protection features with embedded failsafe mode
- **Integration:** Unique daisy-chainable SPI control for dual low RDSon channels in a single package
- **Accuracy:** 5X better current sensing accuracy over temperature & supply voltage range with unique accurate temperature sensing capability
- **Scalable:** Compatible PCB foot print and SPI software driver among the 24 A/36 V product family
- **Lowest RDSon in Dual Configuration:** 20% smaller PCB due to lower power dissipation when using 12 A/channel or 24 A/dual in a thermally enhanced package

Product Features

- Dual 24 A/36 V high side switch with 6, 10, 16, 22 or 50 mW RDSon channels
- Normal operating range: 8.0 – 36 V, extended range: 6.0 – 58 V
- Flexible load management 1-24 A with possible parallel output operating modes
- Programmable dynamic threshold over current protection and over-temperature protection with programmable auto-retry functions
- 3.3 V and 5.0 V compatible 16-bit Daisy chainable SPI control
- $\pm 5^\circ\text{C}$ temperature and synchronous / asynchronous current ($\pm 10\%$) sensing
- Individually programmable internal/external PWM clock signals

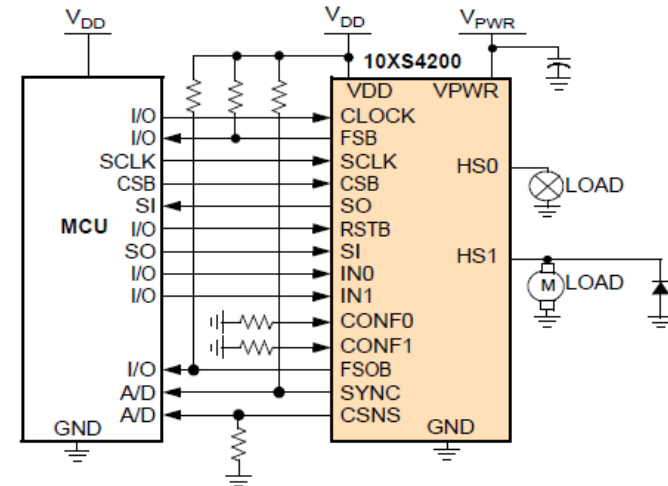

Typical Applications

- Transportation 12 / 24V
 - 24 V Lighting and capacitive loads
 - Valves
 - DC motors
- Industrial
 - High current / highly inductive loads (solenoids)
 - DC Motor control
 - Factory automation



eXtreme Switch Target Applications – Up to 36V Operating Voltage

DC Motor

- Heater
- Electric doors
- Wiper
- Washer pump
- Low end robotic
- Machine inspection
- Vending machines
- HVAC
- Hospital bed controller

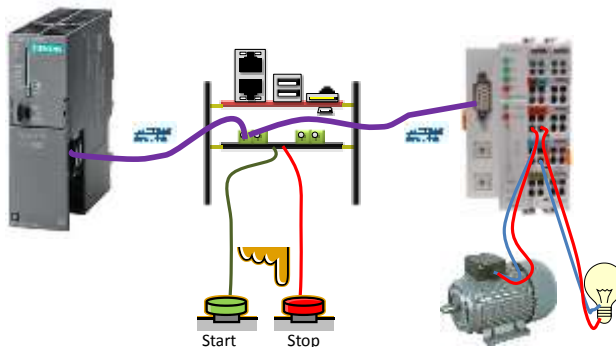

Inductive loads

- Solenoids
- Water and fluid control app
- Valves controllers for thermostats
- Home Automation system

Factory Automation

- PLC
- Industrial printing systems
- POS terminals

Capacitive loads

- External lighting
- Xenon
- Halogen
- LEDs

Motor Driver



Industrial & Medical Motor Applications



Video Conferencing / Cameras



ATM /
Cash counter



e-Bike



CPAP



Gas Meters



Home Automation



Robots



Electric
scooter



Auto Injectors



Drones



Pumps



Vacuum
robots



Cordless
Power tool

Low Voltage H-bridge Family for DC and Stepper Motors

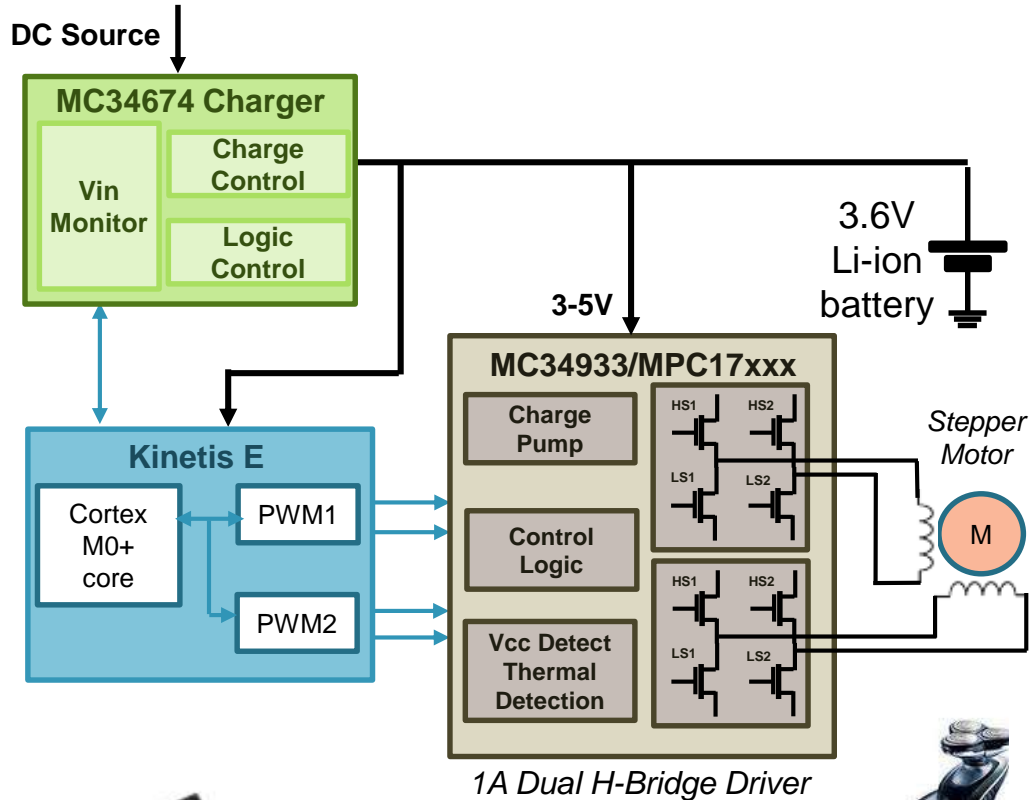

Differentiation

- 9 IoT actuator variants
- Operation from 2V to 15V
- Peak current 0.4A to 3.8A
- Independent PWM drivers
- PWM frequency up to 200kHz
- Single and dual configurations

Applications

- Digital camera
- Video conference
- DVD player
- Personal care products
- Medical



MC3x931/2 36V/5A 1x/2x H-bridge DC motor drivers

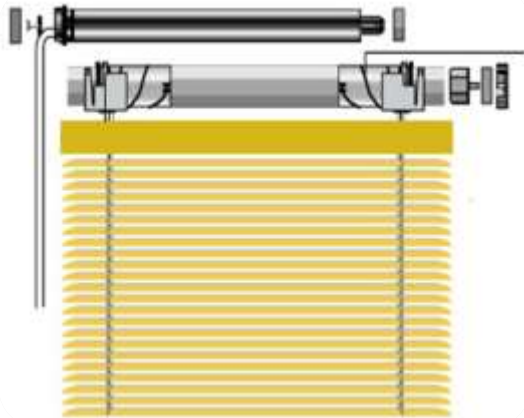
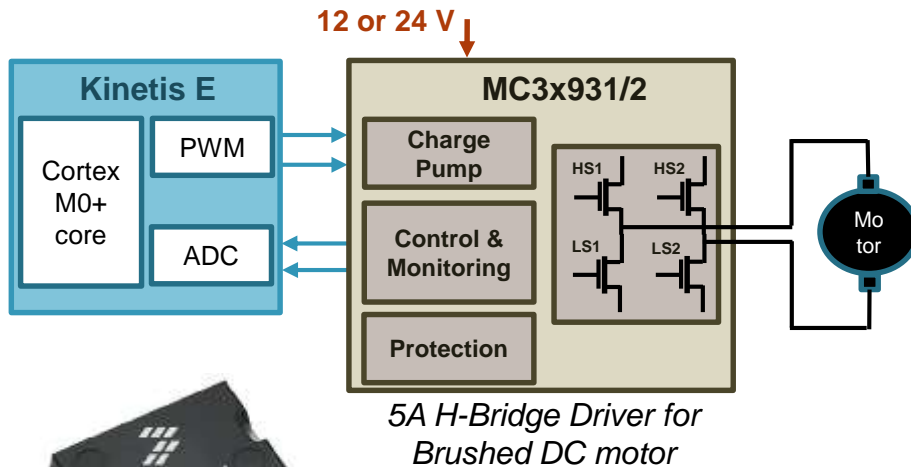

Differentiation

- PWM or SPIDrive control
- High current, high temp operation
- 2x lower thermal impedance
- High efficiency 125 mΩ RDSon
- Automatic thermal back-off for maximum drive operation
- Real-time load current monitoring
- >10A over current threshold

Applications

- Throttle control
- Exhaust gas recirculation
- Shock absorber / braking
- Tube motors
- Robotics / factory automation
- POS, ATM, vending kiosks

MC34937 3-phase Pre-drive IC

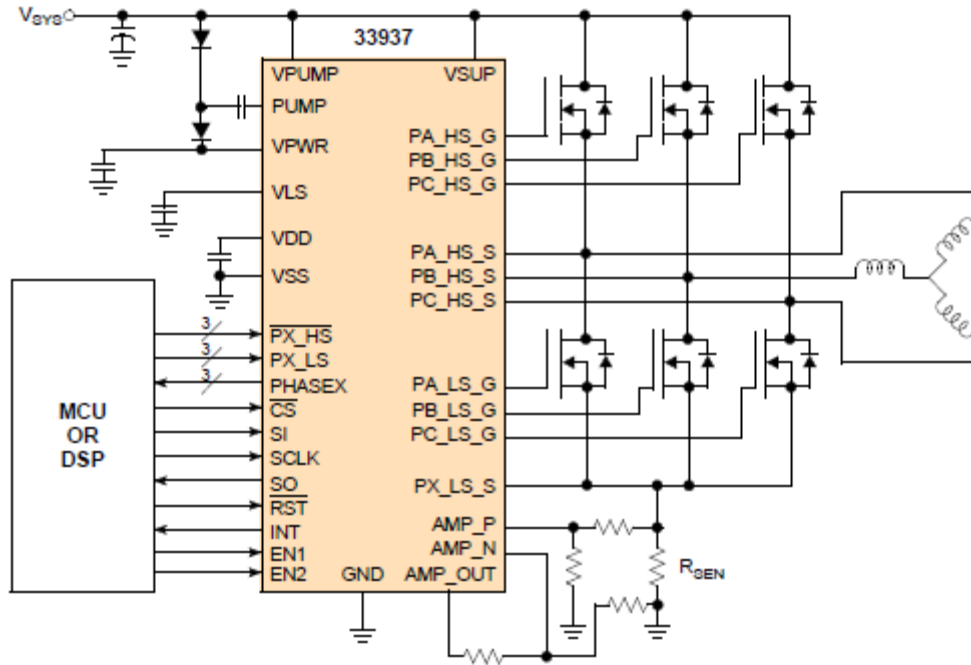

Features

- Up to 55V operating voltage range
- > 1.0 A peak gate drive current
- Wide SPI programmable dead time range
- Protection against transient spikes and reverse charge injection

Typical Applications

- Medical
- Power Tools
- Pumps / Fans

Product Options

-40 to 135°C

MC33937APEK

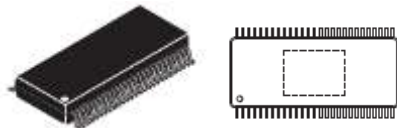

54-Pin, SOIC-EP
10x18 mm

Availability

Samples: Now
Production: Now

BMS and Battery Charger

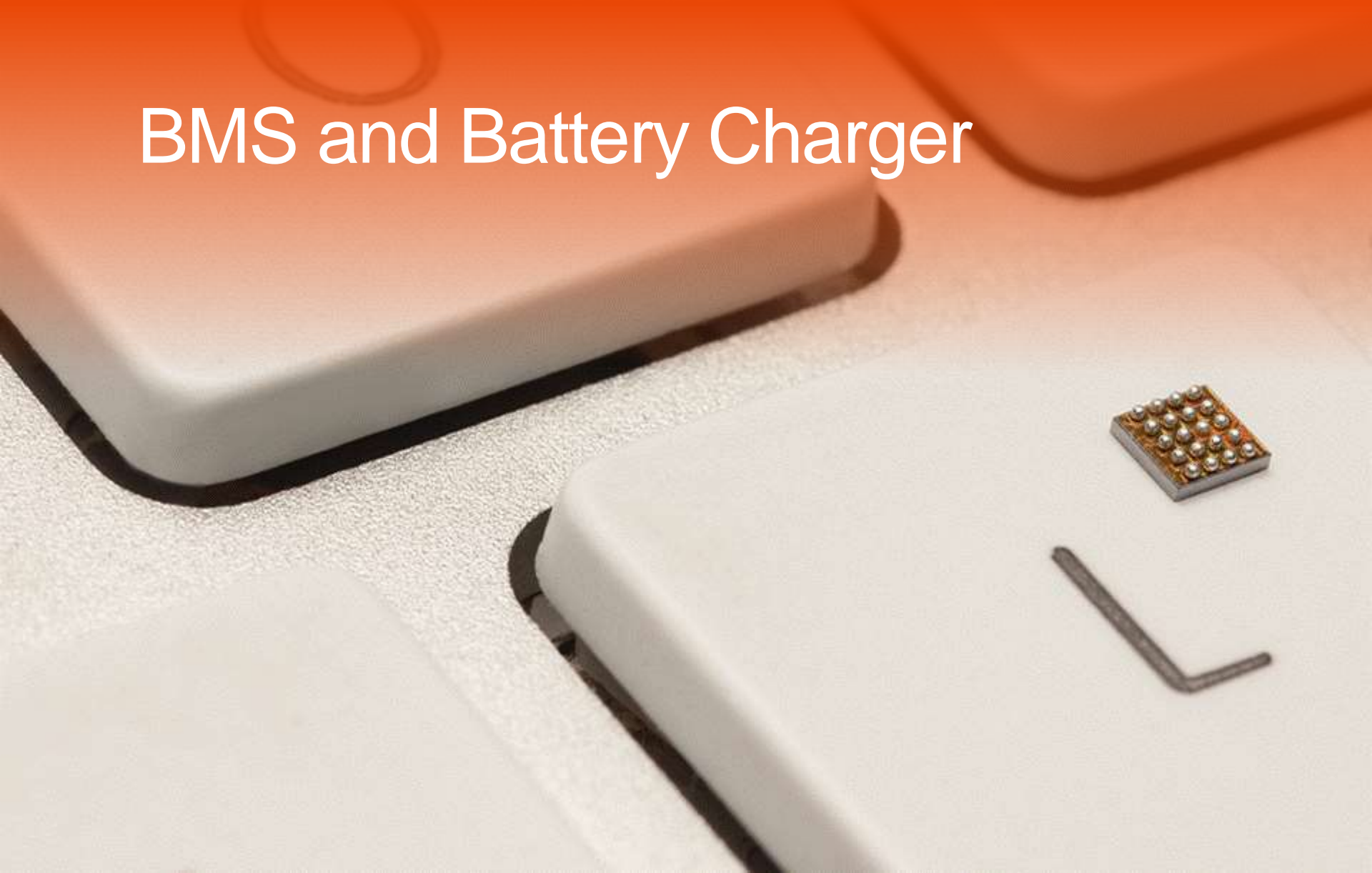

Battery Management Solutions

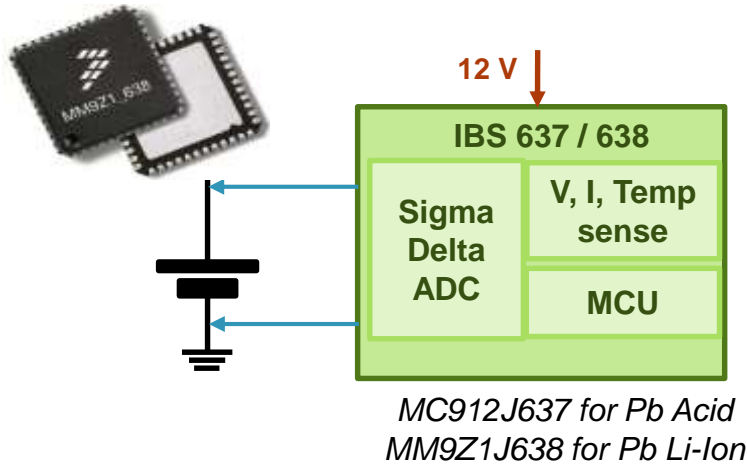

Intelligent Battery Sensors

- 12V Pb-Acid, 14V Li-Ion, HV junction box
- 4 cell with 52V measurement capability
- First IBS in production with CAN
- Lower average system current
- Configurable HW filters off-load MCU
- LIN conformance, robust EMC/ESD reduces BOM count and footprint

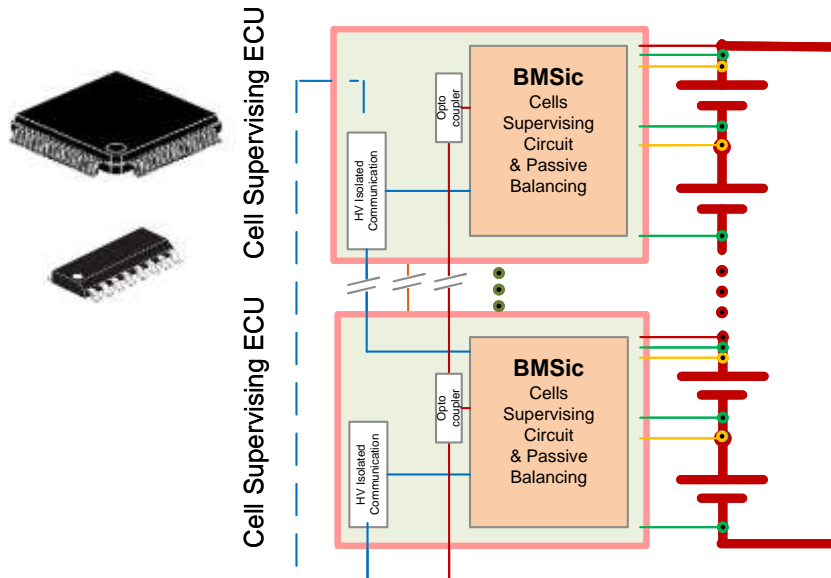

Battery Cell Controller

- 14 cell single chip 61V, multi-chip >800V
- ASIL-C w/ system diagnostics
- 2 Mbps transformer based isolation
- 1 shot cell impedance determination
- Topology flexibility

Milestones	MC33771	MC33664
Datasheet & EVB	Available	Available
Beta Samples	Jul-2014	Jul-2014
Release to Production	Jun-2015	Dec-2014

MC33771 14 Cell Li-ion Battery Cell Controller

Scalable ISO26262 ASIL-C compliant controller for 48 to >1000 V packs with 2 Mbps transformer coupled daisy chain transceivers, cell balancing FETs and current sensors reducing BOM cost 50%



Differentiating Points

- **Single chip** 48 V battery control scalable to > 1000 V
- **ASIL-C** functional safety compliant at 50% system BOM cost
- **300 mA** cell balancing transistors and 0.5% current sensors
- **2 Mbps** differential communication transceiver
- >2.5x higher transformer coupled daisy chain isolation (3750 V)
- Companion communication interface IC for MCU SPI isolation
- **2 mV** voltage measurement accuracy
- 65µs one shot synchronized cell impedance determination
- **Fast data acquisition:** 3.6 ms for 96 cells, 4.5 ms for 112 cells
- Functional verification & **diagnostics** supporting ISO26262
- Automotive robustness: ESD, EMC, **Hot plug**, AEC Q-100

Product Features

- **9.6 V ≤ VPWR ≤ 61.6 V** operation, 70V transient
- **14x** differential cell voltage + stack voltage measurement
- **7x** ADC + GPIO + temperature sensor Inputs
- Low power modes
- 64 pin QFP package
- Low-level drivers to simplify SW development

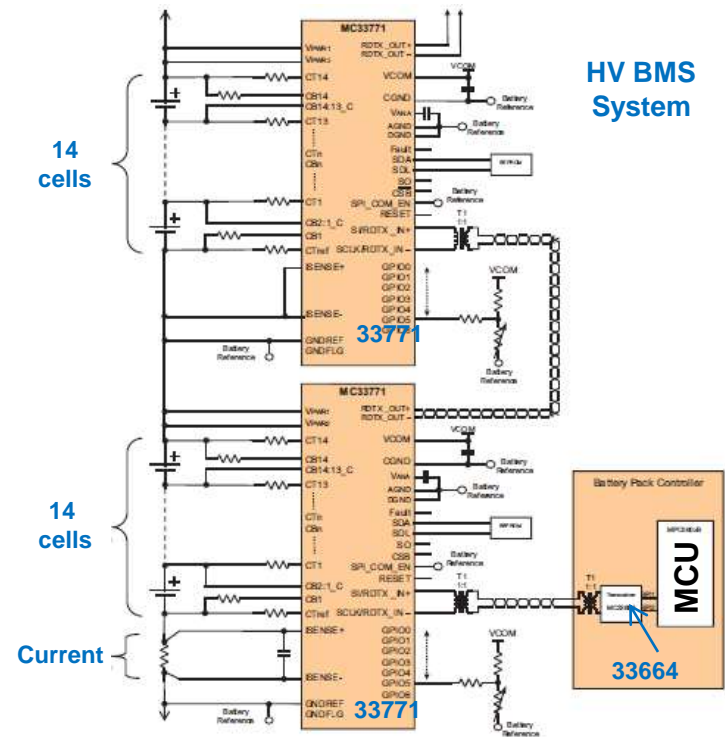

Typical Applications

- Automotive hybrid and electric vehicles
 - 48 V BMS and HV BMS (>1000V)
- Industrial
 - Energy storage systems (ESS)
 - Uninterrupted power supply (UPS)
 - E-bikes, E-scooters





MC33771 - Connectivity

SPI based solution

MC33771 Battery Cell Controller

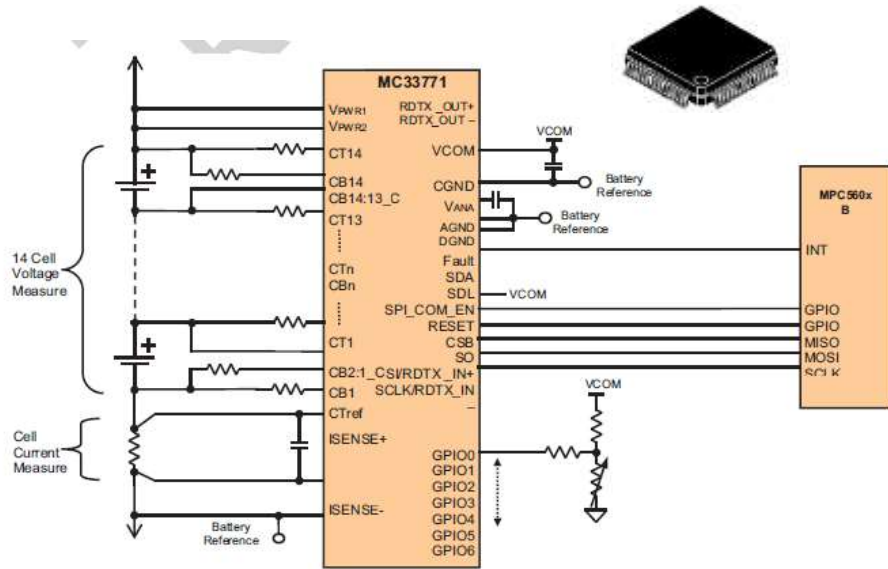

Figure 1. Low Voltage Simplified Application Diagram

Daisy Chain solution

MC33771 Battery Cell Controller + MC33664 Physical Layer

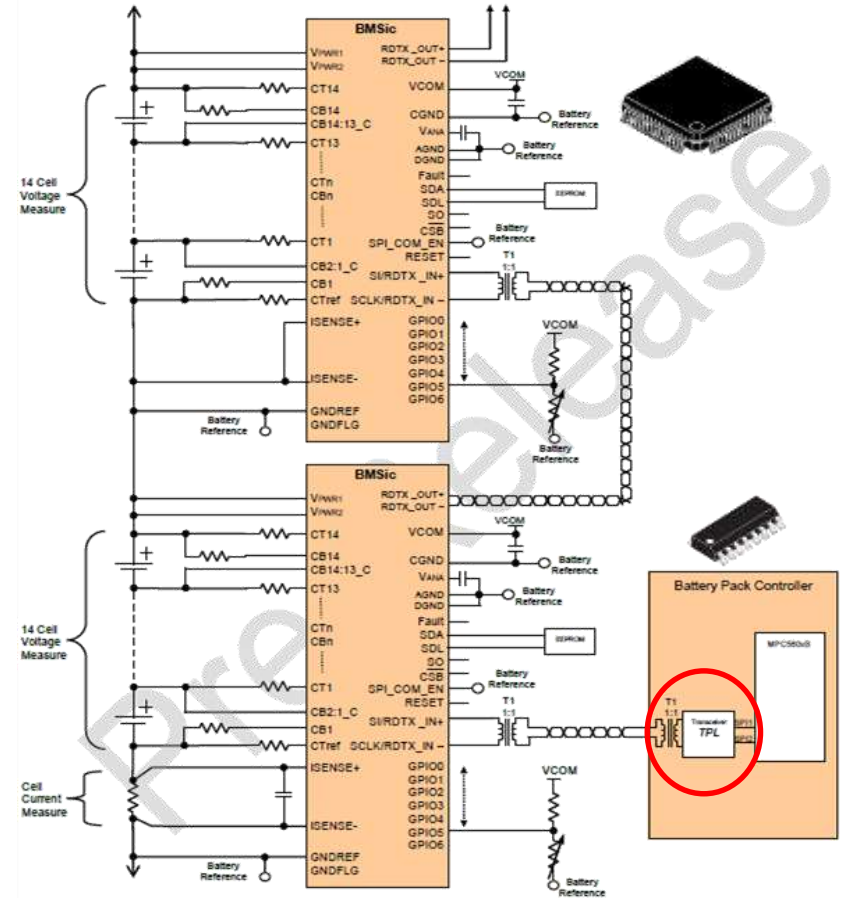
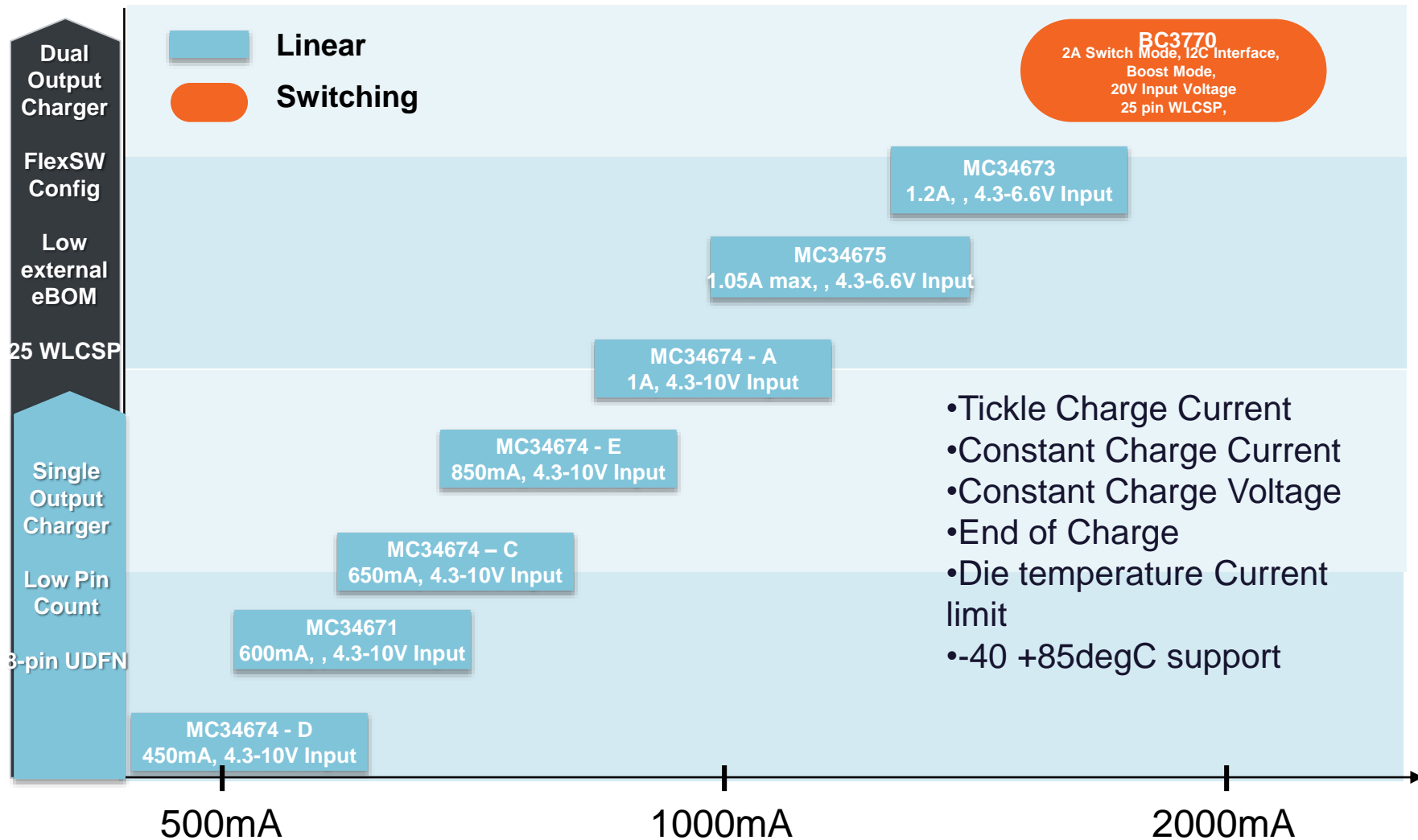

Figure 2. High Voltage System Application Diagram



Freescale Battery Charger Offering







Sensor Solutions Division

Freescale provides intelligent sensor solutions that expand contextual and environmental intelligence to advance the human experience.



Sensor Portfolio

	Pressure	Automotive, industrial, medical and consumer absolute and differential sensors <i>Flow, comfort management, HVAC, medical, engine control</i>
	Accelerometer	Consumer and industrial low-g sensors and tilt sensors Automotive medium- and high-g crash sensors <i>Vehicle stability, airbag, vibration monitor, tilt alignment</i>
	Magnetometer	Consumer and industrial magnetic field sensor and 3D compass <i>Orientation alignment, proximity detection, magnetic switch</i>
	Gyroscope	Consumer and industrial angular rate sensors and 6/9-DOF IMU Automotive roll sensor and IMU <i>Stabilization, motion and gesture HMI, inertial navigation, gaming</i>
	Sensing systems	Consumer and industrial MCU and sensor integrated platforms Automotive tire pressure monitoring system <i>Smart sensors, pedometer, anti-tamper, fault prognostication</i>

Another Billion Sensors Shipped in 5 Years



FREESCALE SENSORS
1
BILLION
UNITS SHIPPED

FREESCALE SENSORS
2
BILLION
UNITS SHIPPED



Industrial Accelerometer Family



FXLS8471

- SPI / I2C Output
- Extreme Perf.
 - .25mg/count sensitivity
- Extended Features
 - FIFO
 - Configurable P/L trip angles
 - High Pass Filter
 - Vector Magnitude

High Performance
Digital



MMA8491

- I2C Output
- Extreme Low Power
 - 0.35uA/Hz
- Cost Efficient
 - 1mg/count sensitivity
- Digital outputs for tilt detect
- Industrial Package

Low Power Tilt
Detection



FXLN83xx

- Analog Output
- High Bandwidth
 - 2.7kHz
- Low Voltage
 - 1.71-3.6V
- $\pm 2g$ to $\pm 16g$ selectable range
- Industrial Package
- Extended Temp Range: 105C

High Bandwidth
Analog



FXLS8471

3-Axis High-Performance Digital Accelerometer (SPI Interface)

Differentiating Points

- Output noise (99 ug/rHz)
- Offset and sensitivity accuracy
- Resolution of 0.25 mg/count

Product Features

- 1.95 V to 3.6 V supply voltage
- ± 2 g/ ± 4 g/ ± 8 g dynamically selectable
- Output data rate (ODR) from 800 Hz to 1.563 Hz
- SPI/I²C digital output interface with interrupts
- Embedded orientation (portrait/landscape)
- Embedded high pass filter
- Embedded 32 sample FIFO

Typical Applications

- Laptops: HDD drop protect
- Washing machine: out of balance detect

FXLS8471Q

14-bit output, SPI
High Pass Filter with DSP functions
Configurable Orientation detect
FIFO



Package

3 x 3 x 1 mm QFN, 0.5 mm pitch

Availability

NOW



FXAS21002C

3 Axis Gyro with Market leading power consumption (over 40% better than the leading competitors)
Part of Freescale's 9-axis Sensor Fusion Solution.

Differentiating Points

- **Best-in-class power performance: 2.7mA (Active), 1.6mA (Ready), 2uA (Standby)**
- Complete sensor fusion enablement suite

Product Features

- Enhanced Selectable Full Scale ranges: **+/-250, +/-500, +/-1000, +/-2000**
- Fast Transition from Standby to Active Mode (**60 ms**)
- Expanded Output data rates (ODR) from **12.5 Hz to 800Hz**
- Zero Rate Change over temperature: **$\pm 0.02 \text{dps}/^\circ\text{C}$ (XY), $\pm 0.01 \text{dps}/^\circ\text{C}$ (Z)**
- Improved Noise: Angular Random Walk = **0.025 dps/rt(Hz)**.
- Angular velocity resolution **$< 0.2^\circ/\text{s}$**
- Programmable interrupts, Power saving features
- 1.95-3.6V supply voltage

Typical Applications

- Controllers: Remotes, Games
- Ruggedized Industrial and Medical Handhelds and Tablets
- Sports Monitoring, Remote control toys, Robots



Package

4x4x1mm QFN, 0.5mm pitch

Availability

NOW





Pressure Sensor Portfolio

A – Absolute
D – Differential
G – Gauge
V – Vacuum

MPX10/12/53

D G

10...53 kPa
SOP, Unibody

Uncompensated

High sensitivity analog output
Need external circuit for compensation and amplification

MPX2 Series

A D G V

10...300 kPa
ChipPak, Unibody

Temperature Compensated

Integrated temperature compensation
Need external circuit for amplification

MPX7 Series

D G

±2...±25 kPa
SOP

Integrated Pressure Sensor

Integrated signal conditioning for temperature compensation, linearization and amplification

MPX4 Series

A D G

6...250 kPa
SOP, SSOP, Unibody

MPX5 Series

A D G V

4...1'000 kPa
SOP, SSOP, Unibody

MPX6 Series

A

100...400 kPa
SOP, SSOP

MPL3115 (Digital I²C)

A

115 kPa Smart Baro/Pressure
3 x 5 mm LGA

Package Examples



Pressure sensor in Medical



医疗应用	飞思卡尔压力传感器	区别
有创和无创血压监护仪、胎心监护	MPX2300DT1, MPX2301DT1, MPXM2053GS, MP3V5050	高质、大量生产，生物相容性，技术支持
睡眠呼吸暂停(CPAP机)	MPXV4006G, MP3V5004, MPXV7002	低成本，高灵敏度，信号放大，多端口配置选项，技术支持
吸入器和呼吸机	MPL115A, MPXC2011DT1, MPXC2012DT1, MPX12GP, MPX5700GP, MP3H6115	小尺寸，高灵敏度，低成本，大量生产，技术支持
病床	MPX2010DP, MPX5010DP	坚固封装，高灵敏度，信号完全放大，技术支持
伤口护理	MPL115A, MPXV2053GVP, MPXV5100G	小封装高度，多端口配置选项，技术支持

MPL3115A2

Precision Digital Altimeter



Differentiating Points

- Internally compensated, software is not needed
- Direct reading pressure in Pascals and altitude in meters



- On-board intelligence

Product Features

- Altitude resolution : < 1 foot / 0.3 m
- Pressure resolution: 1.5 Pa
- Pressure range: 20 – 110 kPa
- Calibrated pressure range: 50 – 110 kPa
- 1.95V to 3.6V supply voltage
- Variable output sampling rate (OST) up to 140 Hz
- Current Consumption:
 - Standby mode: 2 μ A
 - Low-power mode: 8.5 μ A at 1 Hz
- I²C digital interface



Typical Applications

- High Accuracy Altimeter
- Smartphones / Tablets
- GPS Enhancement for Location Based Services

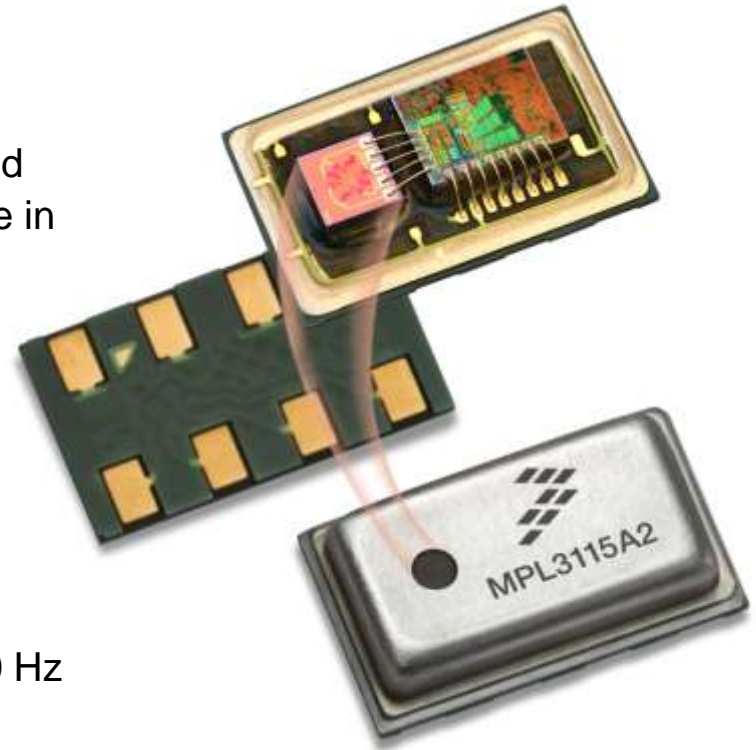

Package

3 x 5 x 1.1 mm LGA

Availability

Now



FXPQ3115MV

I2C Submersible Precision Altimeter

Differentiating Points

- Media resistant to water and salt water; ideal for submersible applications.
- Internally compensated, software is not needed
- Direct reading pressure in Pascals and altitude in meters
- On-board intelligence

Product Features

- Altitude resolution : < 1 foot / 0.3 m
- Pressure resolution: 1.5 Pa
- Pressure range: 20 – 110 kPa
- Calibrated pressure range: 50 – 110 kPa
- 1.95V to 3.6V supply voltage
- Variable output sampling rate (OST) up to 140 Hz
- Current Consumption:
 - Standby mode: 2 μ A
 - Low-power mode: 8.5 μ A at 1 Hz
- I²C digital interface

Typical Applications

- Waterproof fitness watches and activity monitors
- High accuracy altimetry
- Swim tracking equipment

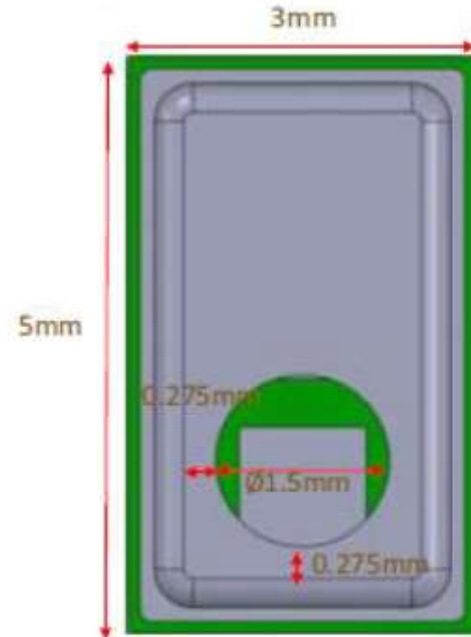

Package

3 x 5 x 1.5 mm LGA

Samples: Q2, 2015
Production: Q4, 2015

MPL3115A2 and FXPQ3115 Target Applications



Pedometer



Sport Bicycle



Fishing Barometer



Aeromodelling



Flying Saucer



Sport Watch

**Altimeter
Barometer
Function**



Analog and Sensor Summary

- Bridging real world physics to connected processors
- Preferred partner for complete embedded system solutions
- Leveraging MCU attach to diversify customers and markets
- Expanding strong automotive position
- Extending leadership with differentiated products

www.freescale.com/analog

www.freescale.com/sensor



Our Products Power The Internet of Things

Microcontrollers | Digital Networking | Auto MCU | Analog and Sensors | RF

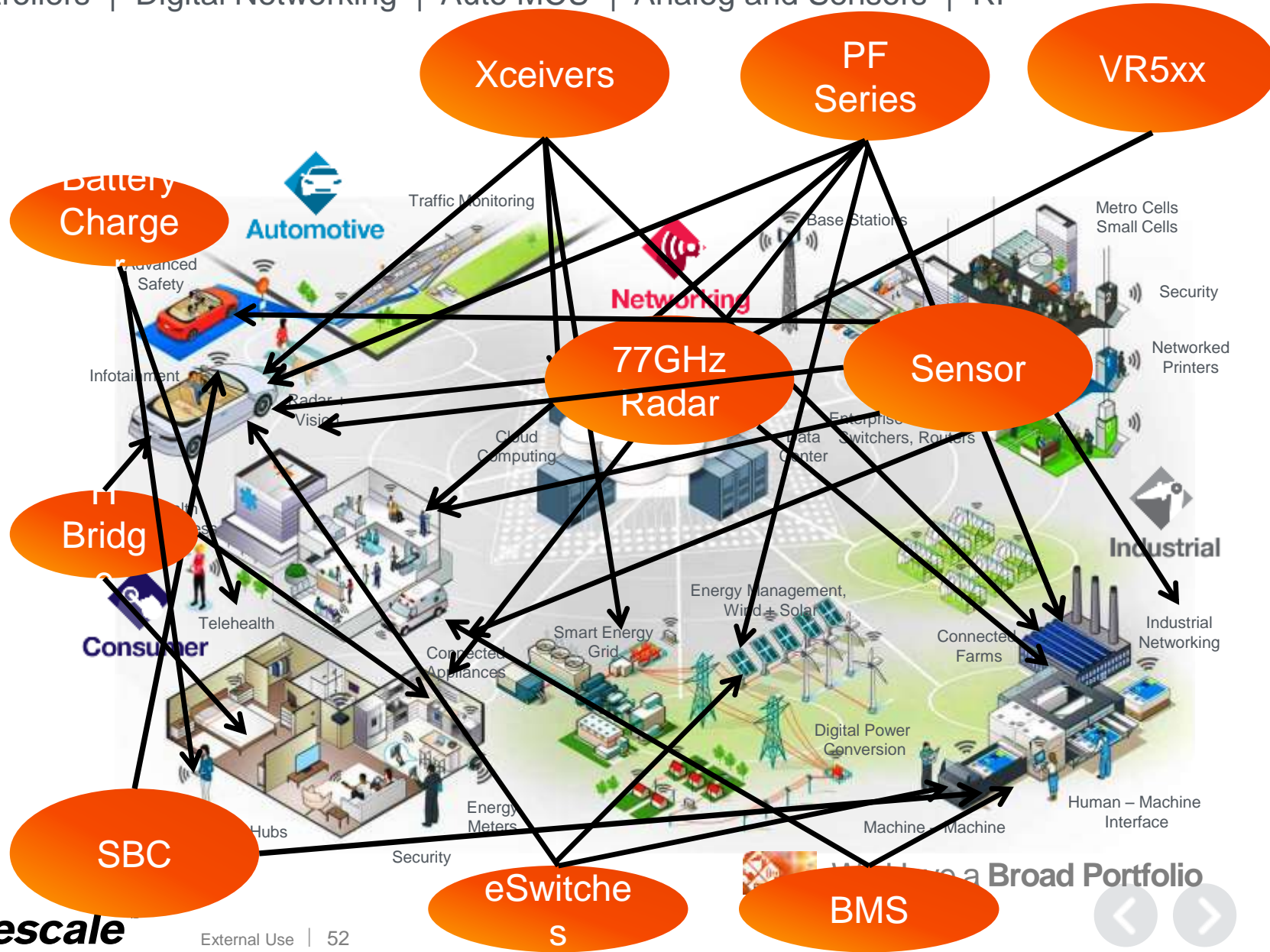



www.Freescale.com