

Revision History		
Rev. Code	Date	Description
E	03/30/2018	Preliminary Conversion from Mentor Design Capture

Page	TITLE PAGE
Page 1	TITLE PAGE
Page 2	LPC546XX/540XX POWER / USB
Page 3	LPC54XXX PORT 0,1 / BOOT SEL
Page 4	LPC546XX/540XX PORT 2,3,4
Page 5	TARGET EMC RAM
Page 6	PMOD/SPIFI/ACCELEROMETER
Page 7	LCD DISPLAY + TOUCH / SD CRD
Page 8	ETHERNET PHY
Page 9	AUDIO CODEC / DMIC
Page 10	SHIELD CONN / PMOD2 / LEDS
Page 11	LPC54XXX CUR MON / LINK2 BRIDGE
Page 12	LINK2 LPC4322 PERIPH / DEBUG
Page 13	LINK2 LPC4322/USB / BRD PWR

**LPC546xx/540xx Development brd**

**NXP**  
411 E. Plumeria DR  
San Jose, CA 95134

This document contains information proprietary to NXP and shall not be used for engineering design, procurement or manufacture in whole or in part without the express written permission of NXP Semiconductors.

ICAP Classification: CP: IUC: X PUBI:

Designer: <Designer>	Drawing Title: <b>LPC546XX / LPC540XX BRD</b>
Drawn by: <DrawnBy>	Page Title: <b>BLOCK DIAGRAM</b>
Approved: <Approver>	Size C Document Number SCHM-LPC546/540XX
Date: Monday, April 02, 2018	Rev E

Sheet 1 of 13

TARGET Hi-SPD  
USB DEVICE / HOST  
MICRO AB

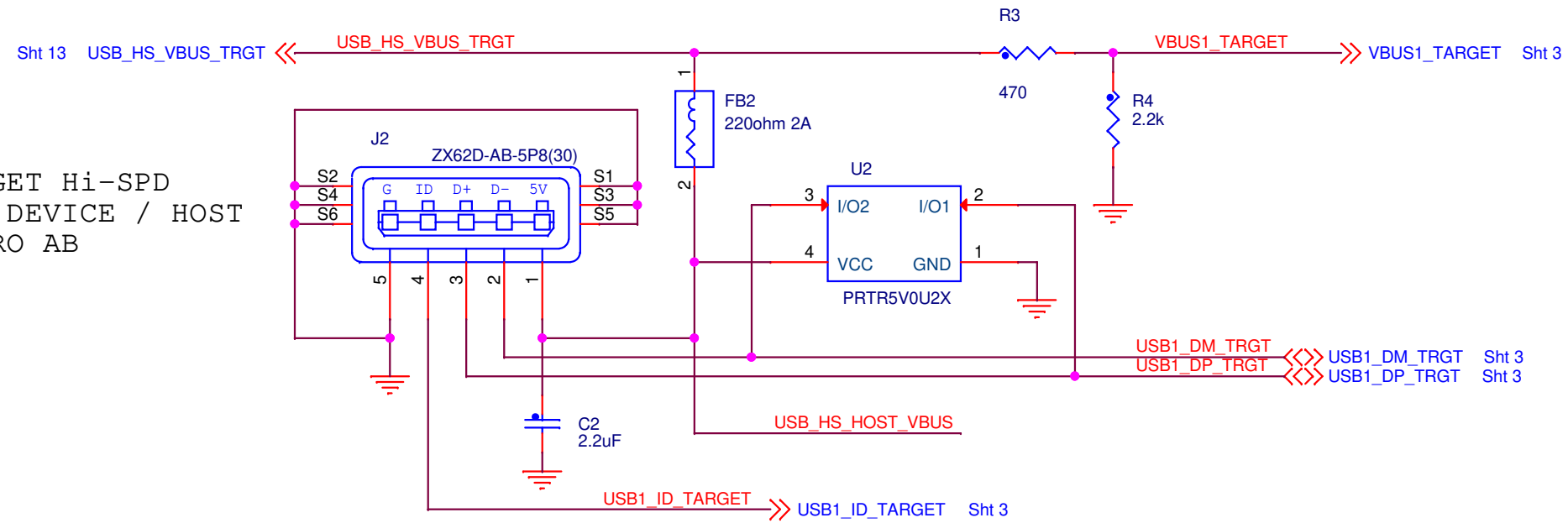

TARGET FULL-SPD  
USB DEVICE / HOST  
MICRO AB

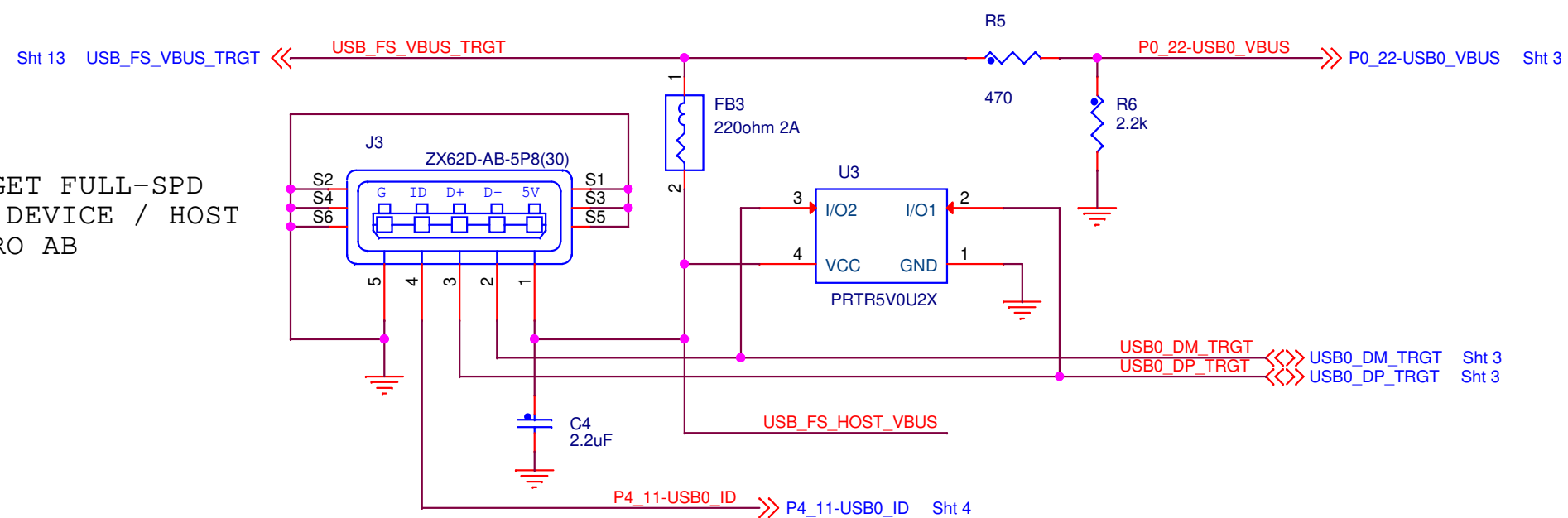

TARGET USB HS / ENET +3.3V POWER

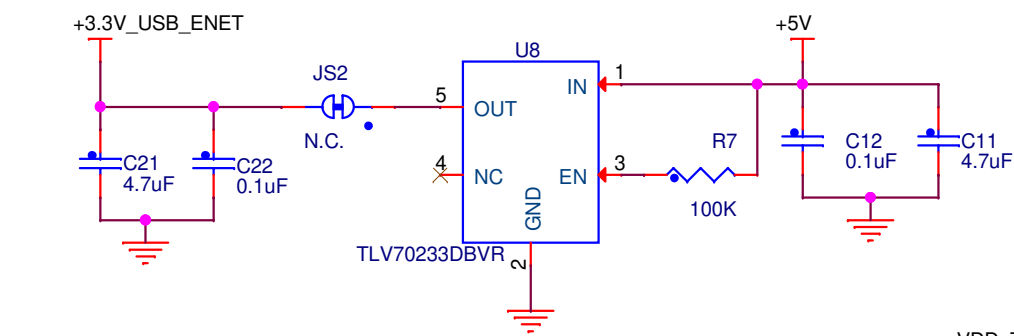

JP9 SETTINGS  
USBX Host VBUS  
USB1 High Spd - shunt 1 - 2 (default)  
USB0 Full Spd - shunt 2 - 3

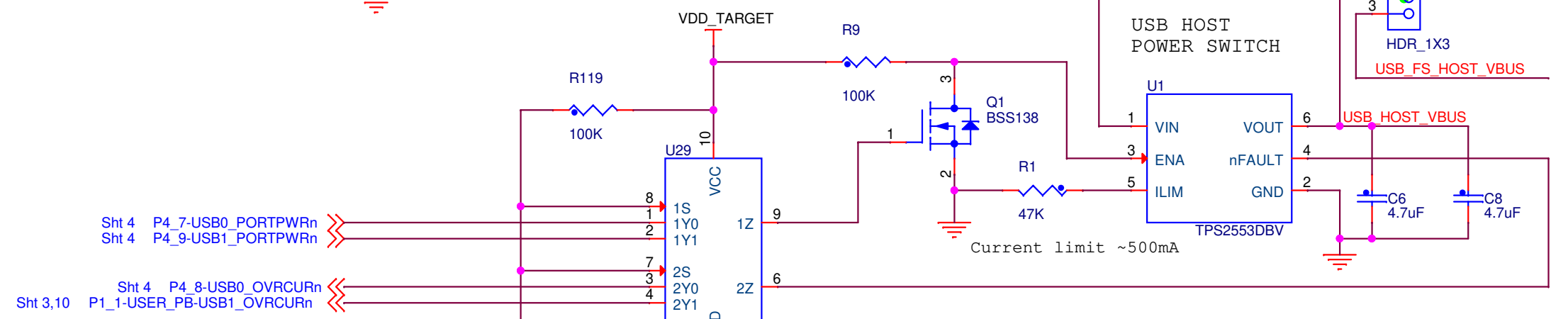

JP10 SETTINGS  
USBX Host Power Control Select  
USB0 Full Spd --- shunt installed  
USB1 High Spd -- open (default)

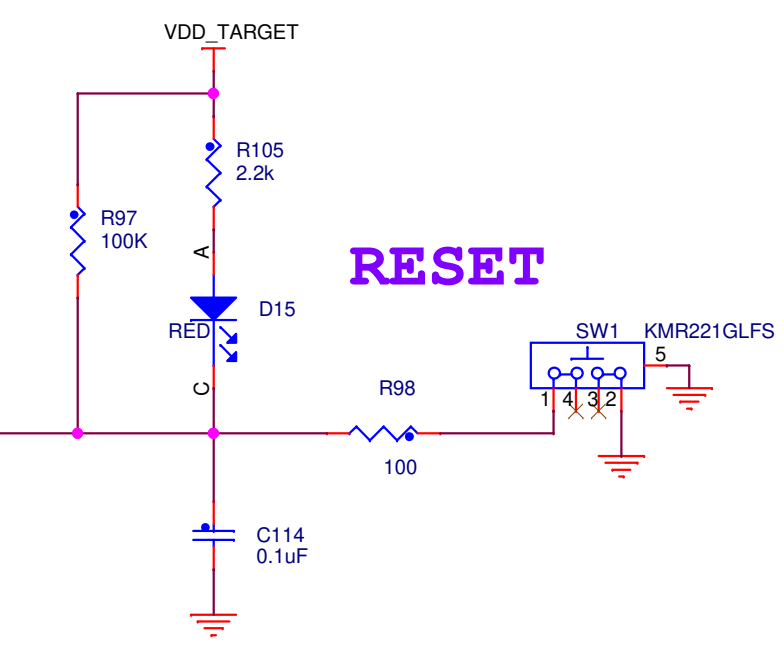
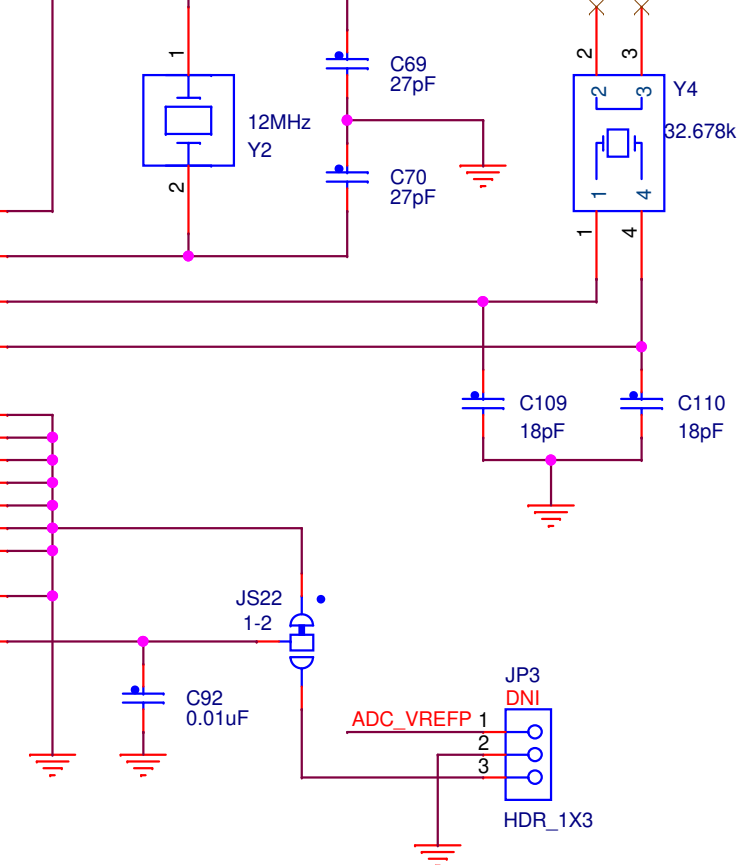
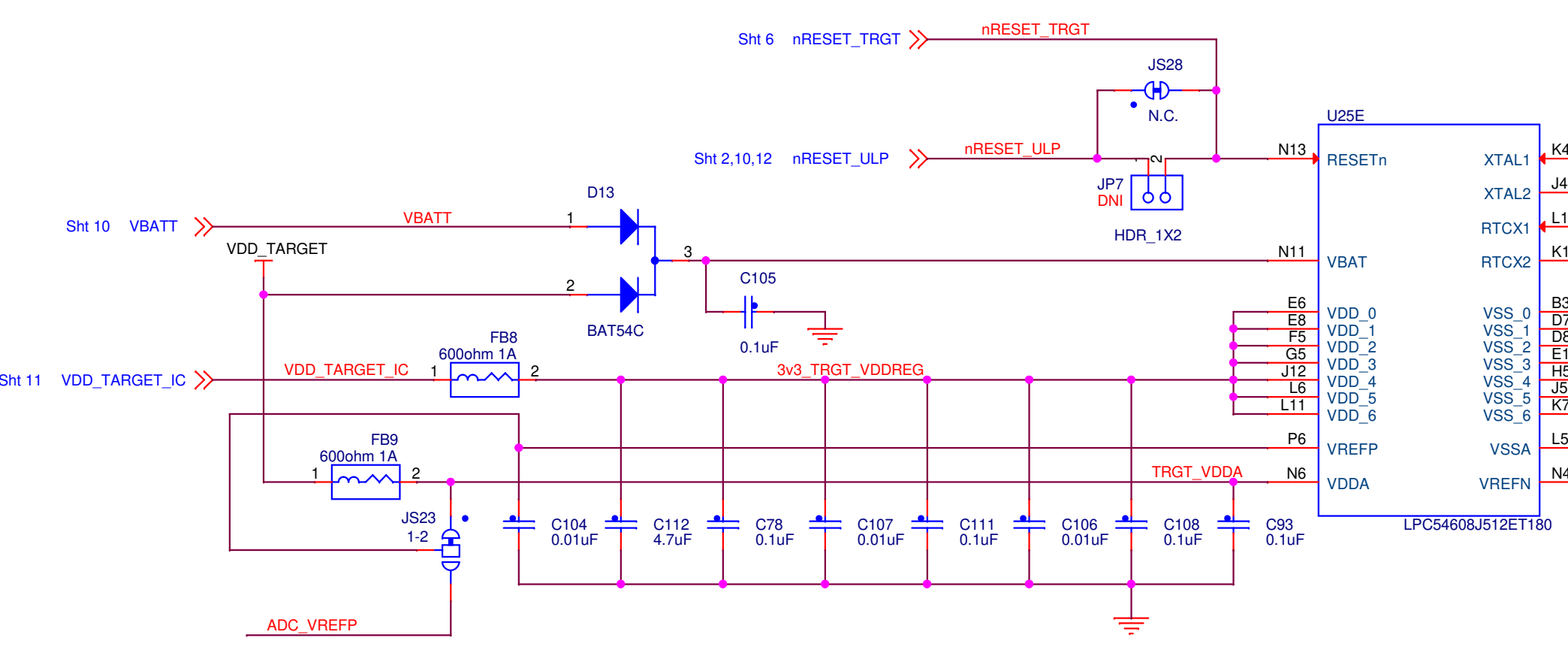

		411 E. Plumeria DR San Jose, CA 95134	
		<small>This document contains information proprietary to NXP and shall not be used for engineering design, procurement or manufacture in whole or in part without the express written permission of NXP Semiconductors.</small>	
ICAP Classification: CP: IUC: X PUBI:		Designer: <Designer> Drawing Title: <b>LPC546XX / LPC540XX BRD</b>	
Drawn by: <DrawnBy> Approved: <Approver>		Page Title: <b>LPC546XX/540XX POWER / USB</b> Document Number: SCHM-LPC546/540XX Rev: E	
Date: Monday, April 02, 2018		Sheet 2 of 13	

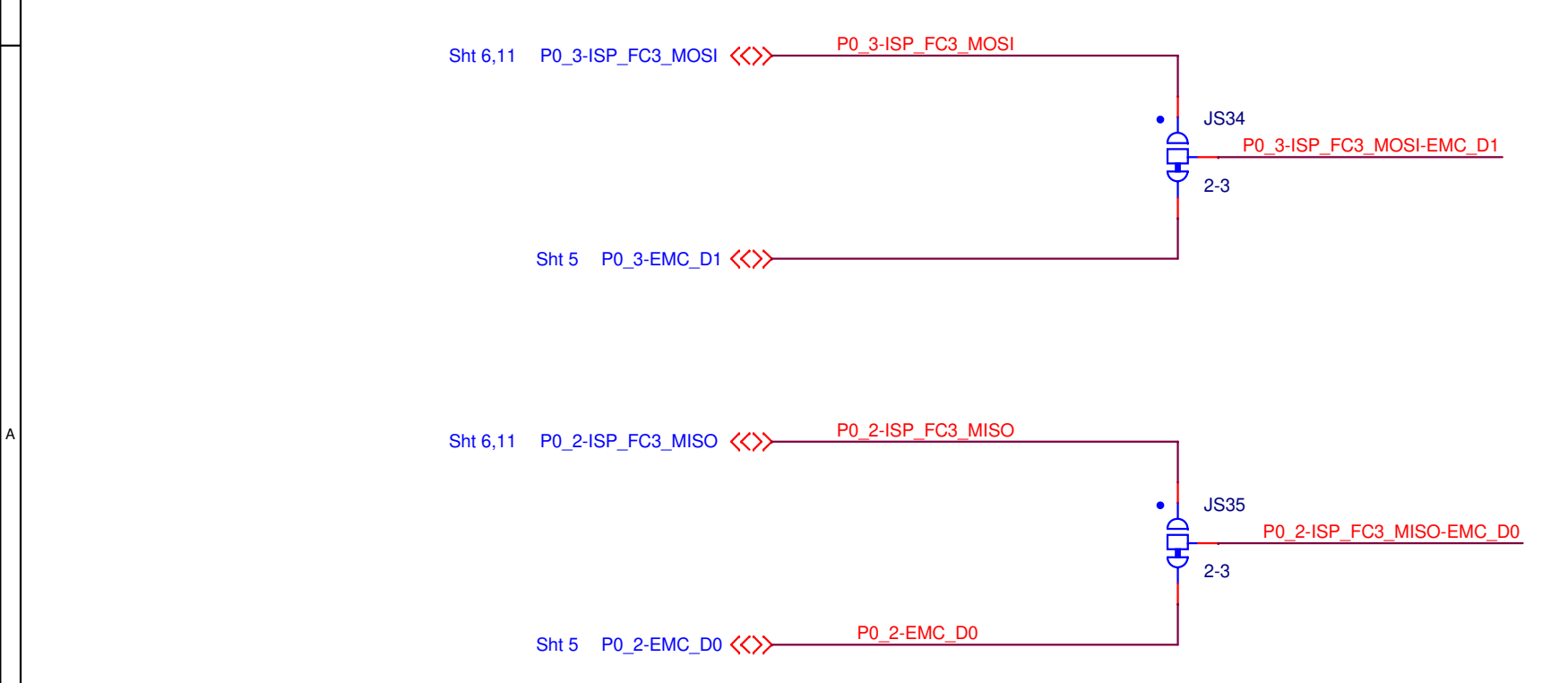
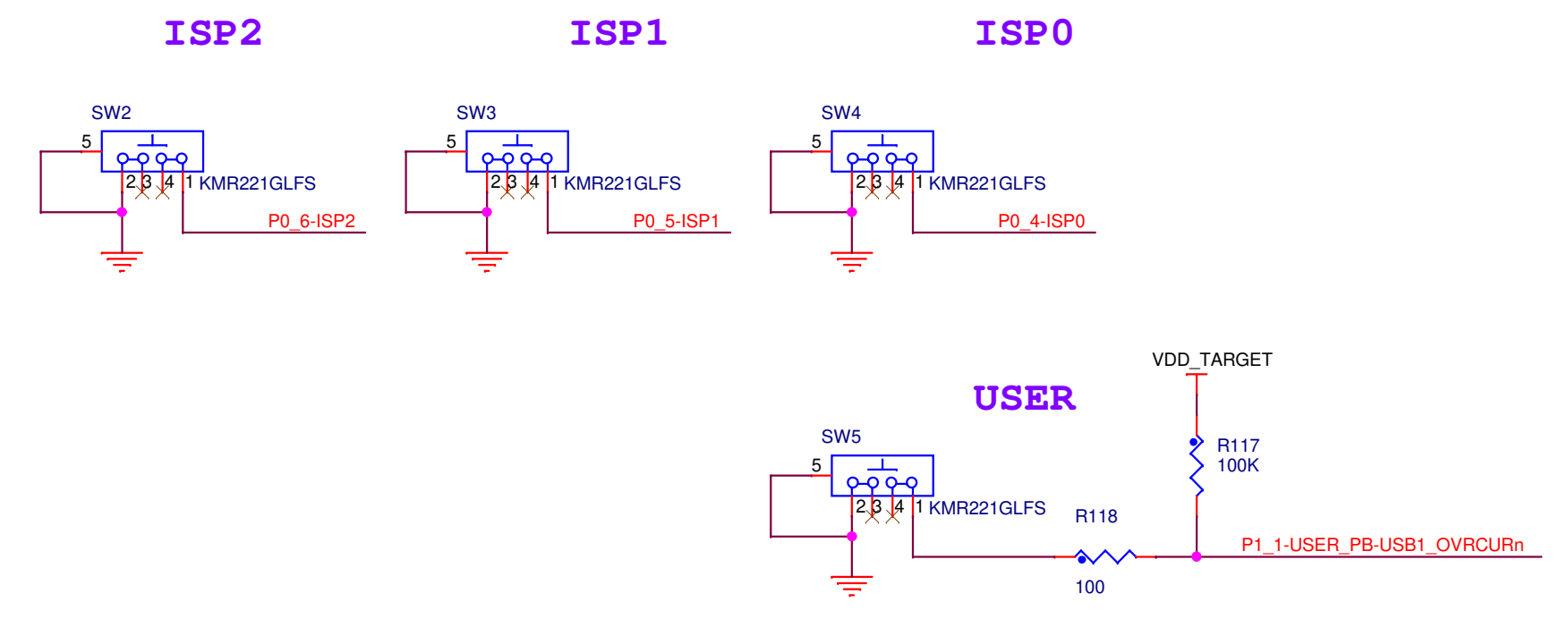
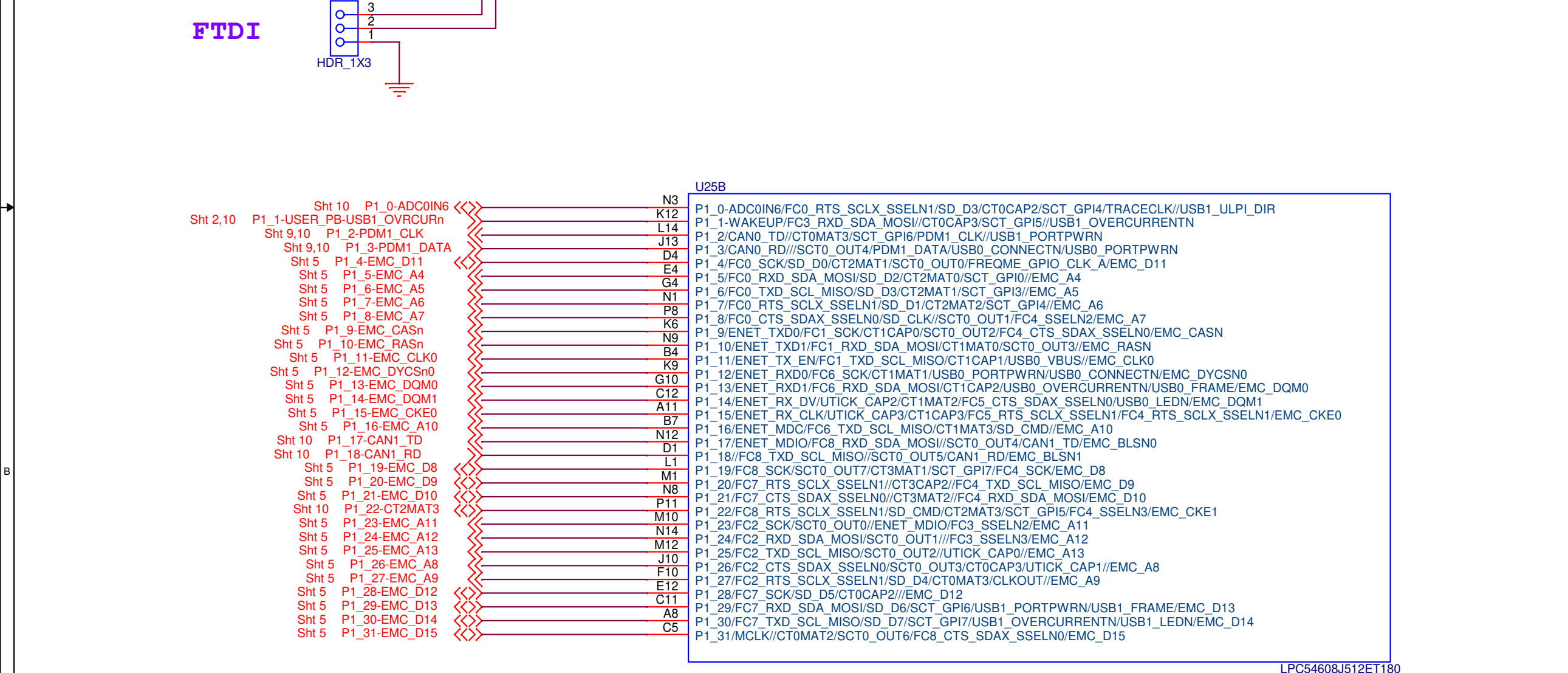
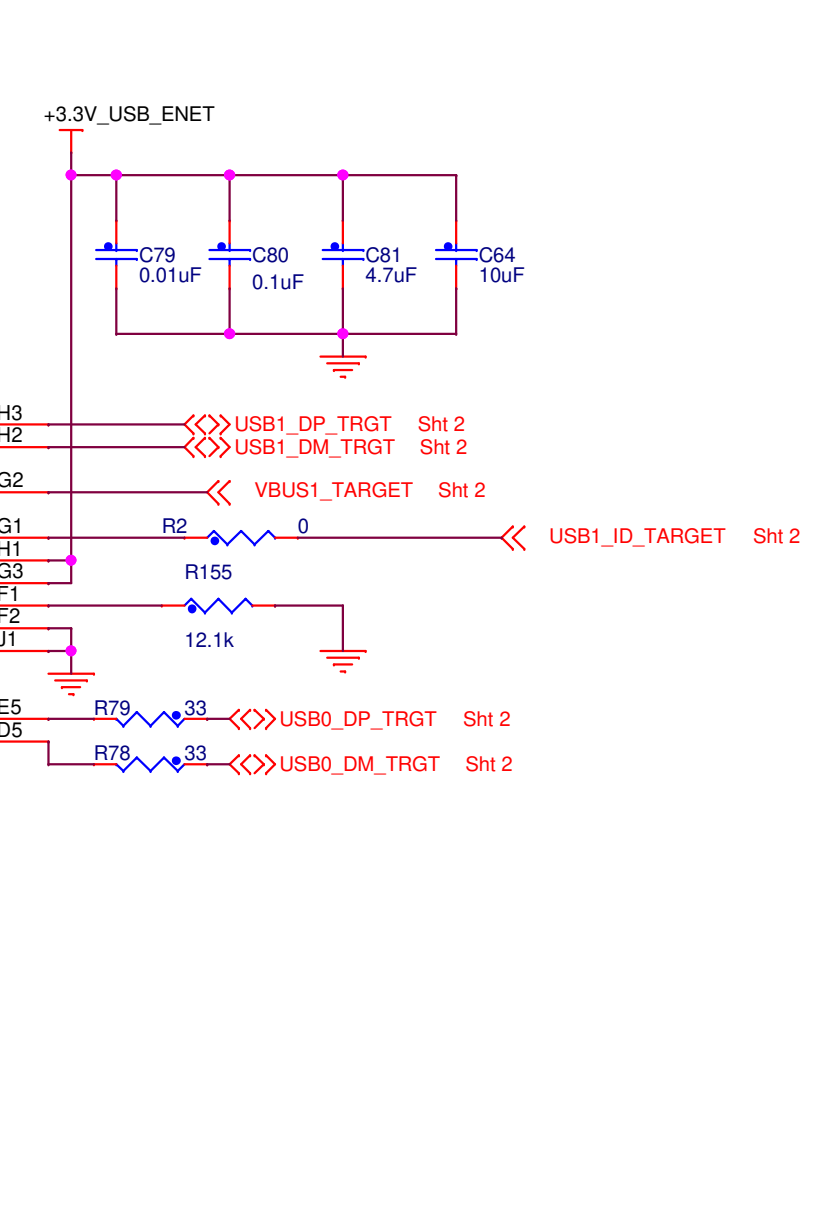
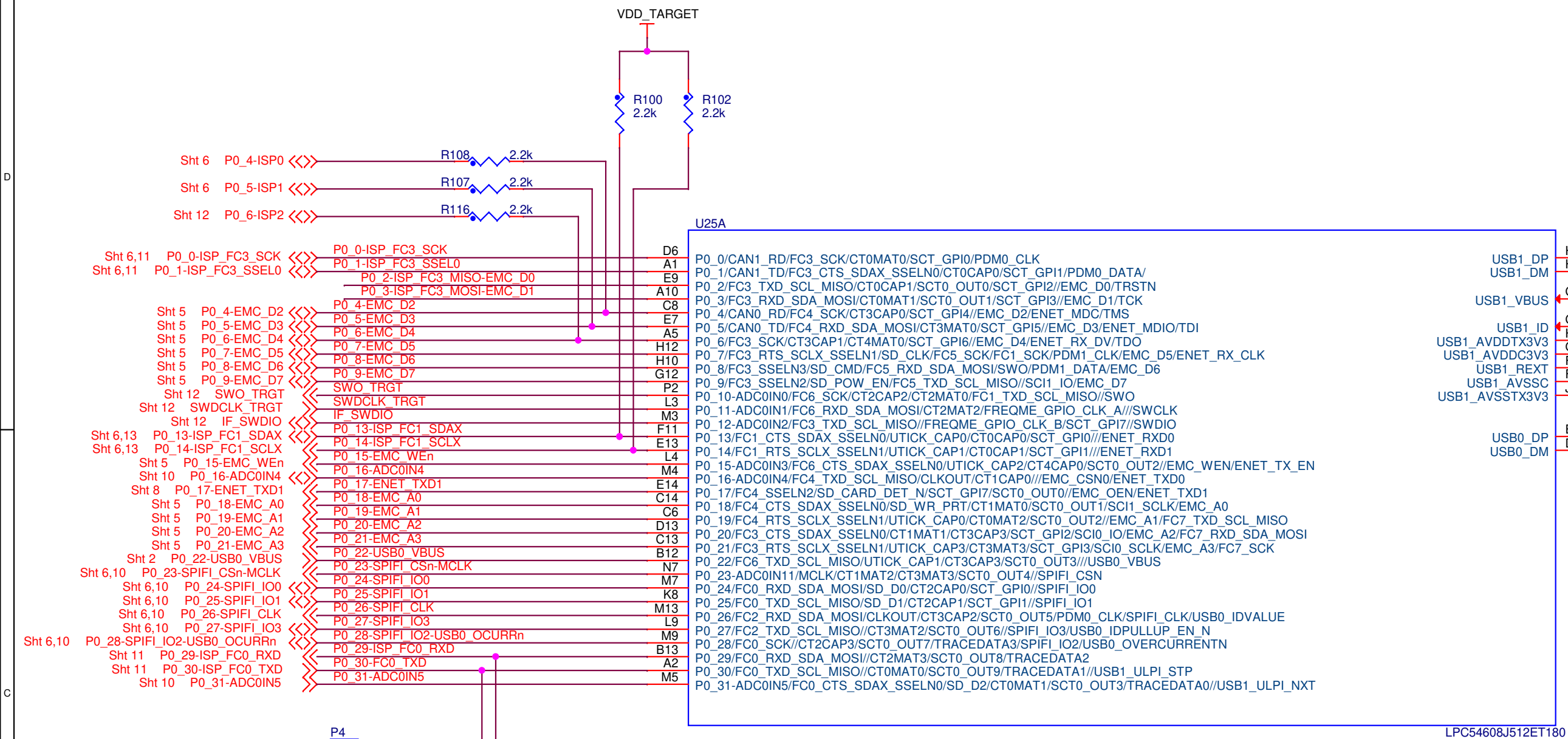

Solder Jumpers		JS33			Solder Jumpers		
		JS34	JS35	JS36			
3.3V		1	2	3	1.8V		
		1	2	3	1	2	3
		2	3	1	2	3	1
		3	1	2	3	1	2

**NXP**  
411 E. Plumeria DR  
San Jose, CA 95134

This document contains information proprietary to NXP and shall not be used for engineering design, procurement or manufacture in whole or in part without the express written permission of NXP Semiconductors.

ICAP Classification: CP: IUC: X PUBI:

Designer: <Designer>	Drawing Title: <b>LPC546XX / LPC540XX BRD</b>		
Drawn by: <DrawnBy>	Page Title: <b>LPC54XXX PORT 0,1 / BOOT SEL</b>		
Approved: <Approver>	Size C	Document Number SCHM-LPC546/540XX	Rev E
Date: Monday, April 02, 2018	Sheet 3	of 13	

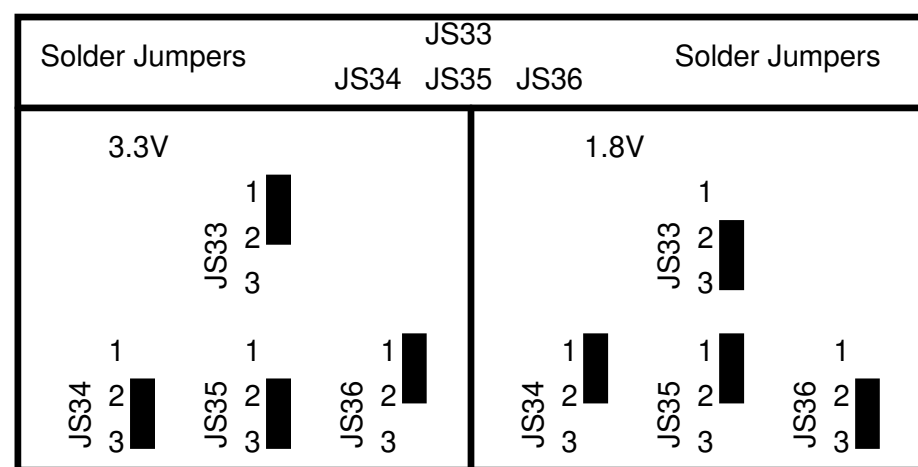
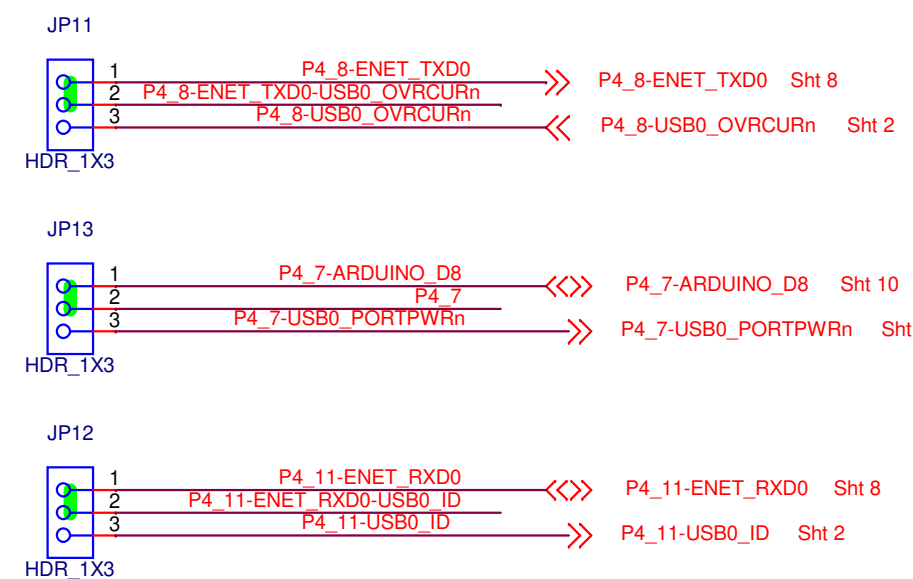
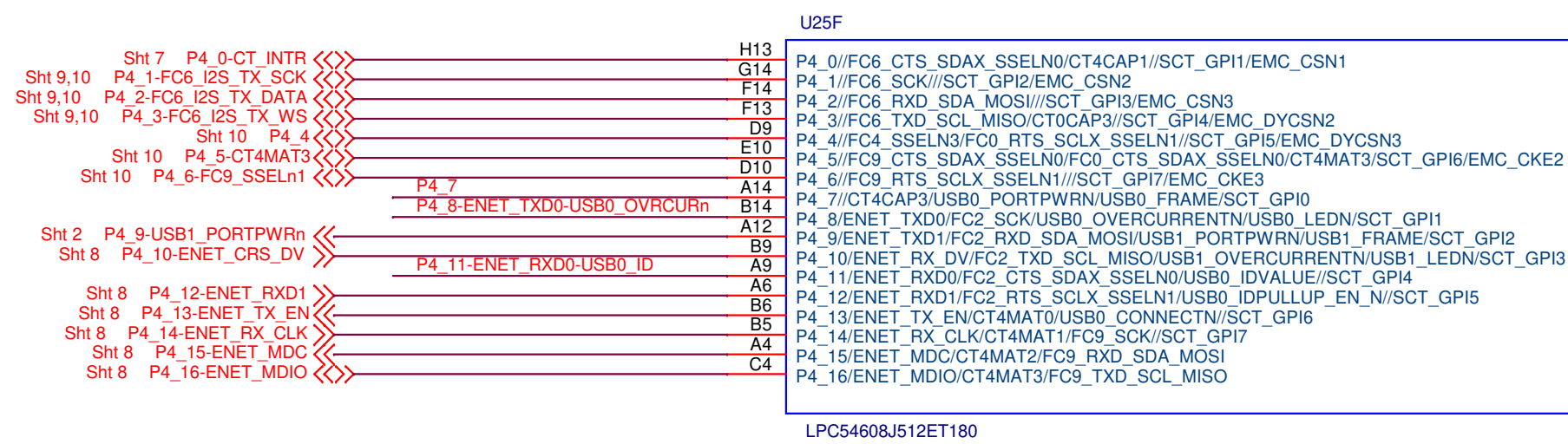
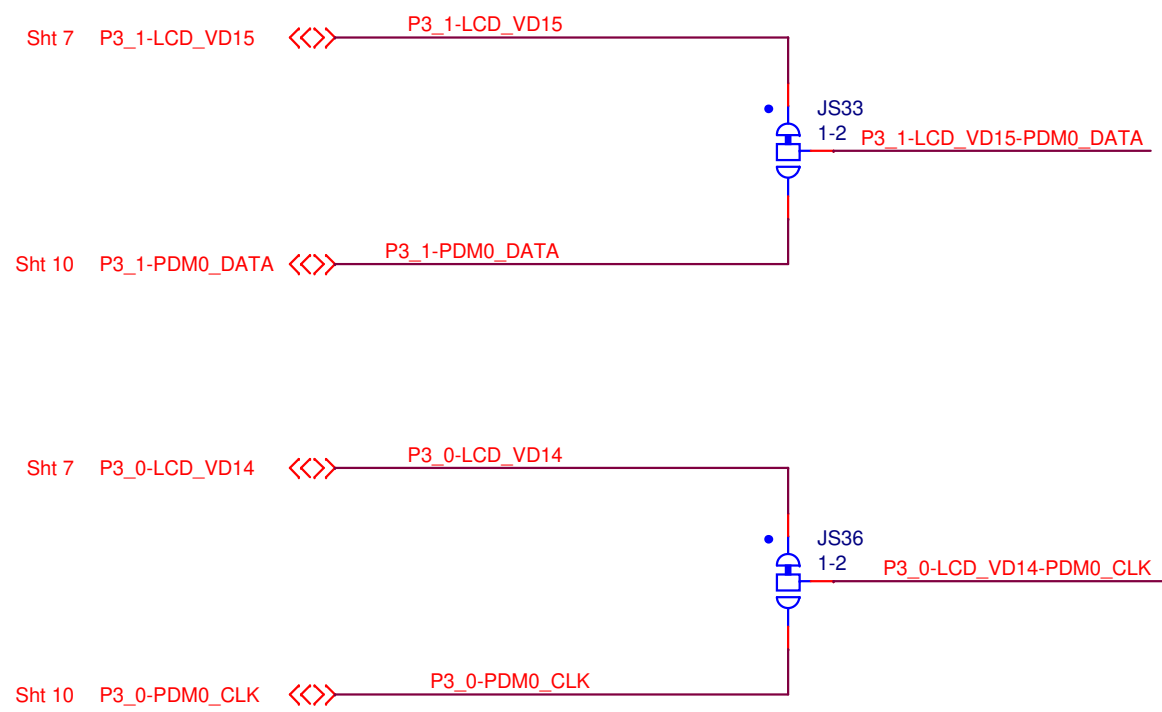
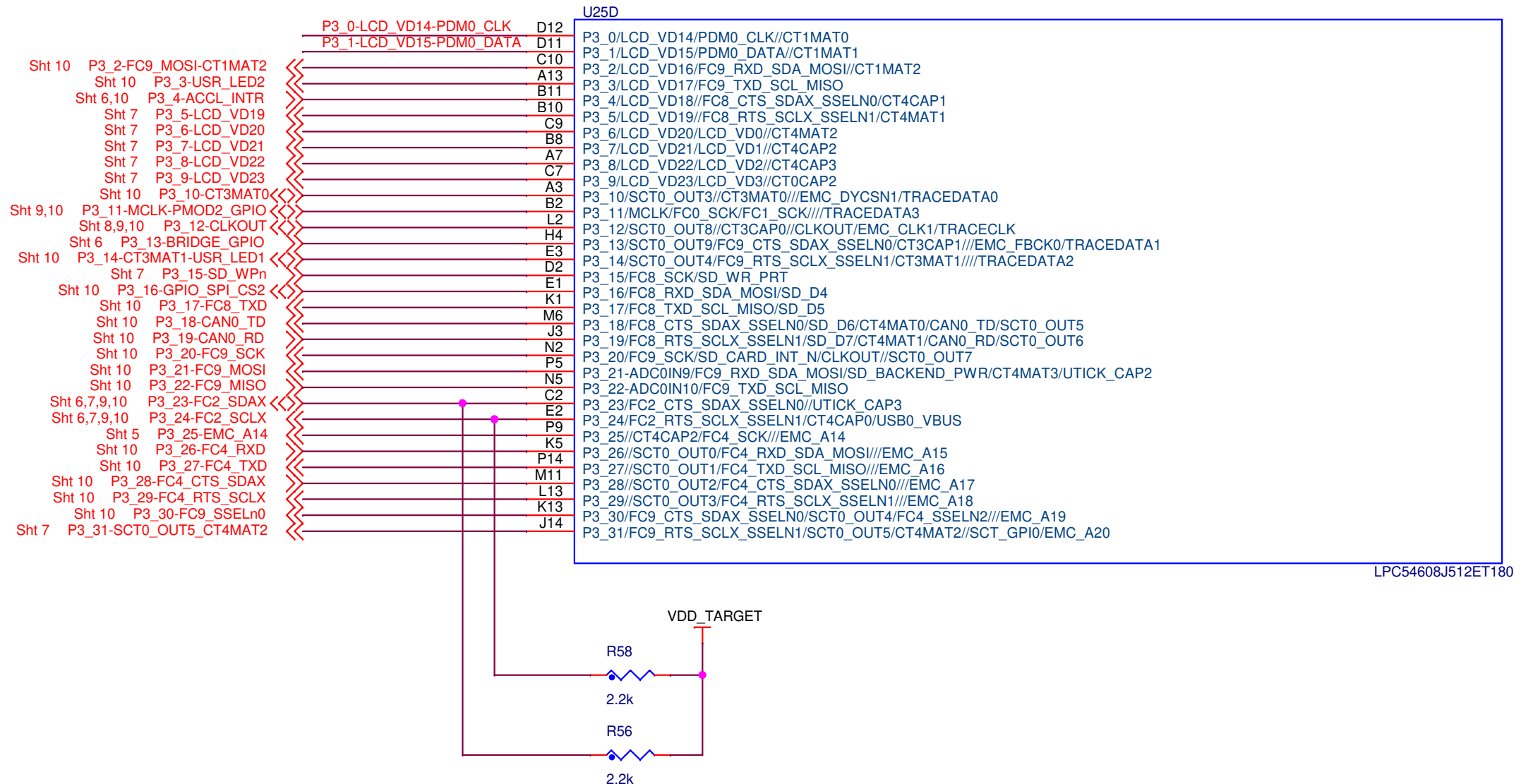
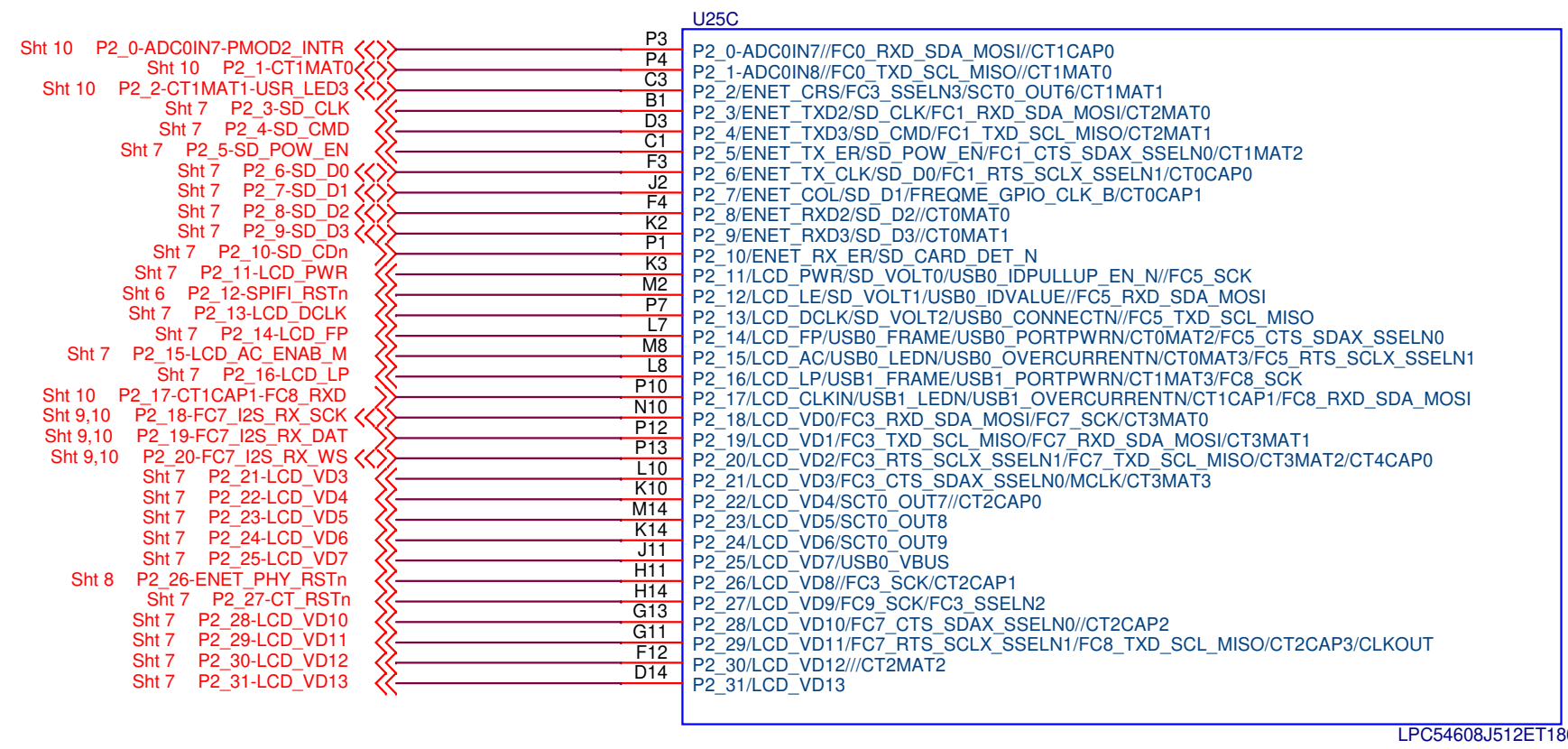

		411 E. Plumeria DR San Jose, CA 95134	
		This document contains information proprietary to NXP and shall not be used for engineering design, procurement or manufacture in whole or in part without the express written permission of NXP Semiconductors.	
ICAP Classification: CP: IUC: X PUBI:		Date: Monday, April 02, 2018	
Designer: <Designer>	Drawing Title: <b>LPC546XX / LPC540XX BRD</b>		
Drawn by: <DrawnBy>	Page Title: <b>LPC54XX/540XX PORT 2,3,4</b>		
Approved: <Approver>	Size C	Document Number SCHM-LPC546/540XX	Rev E
Date: Monday, April 02, 2018		Sheet 4 of 13	

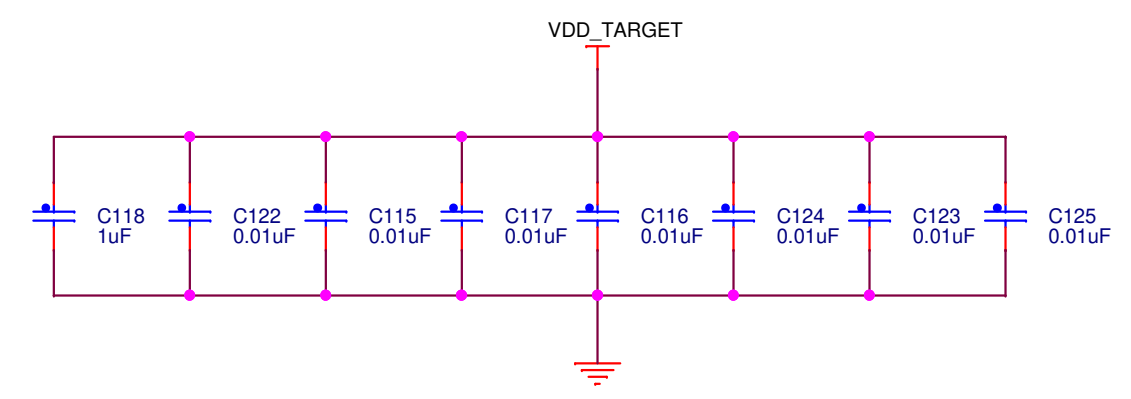
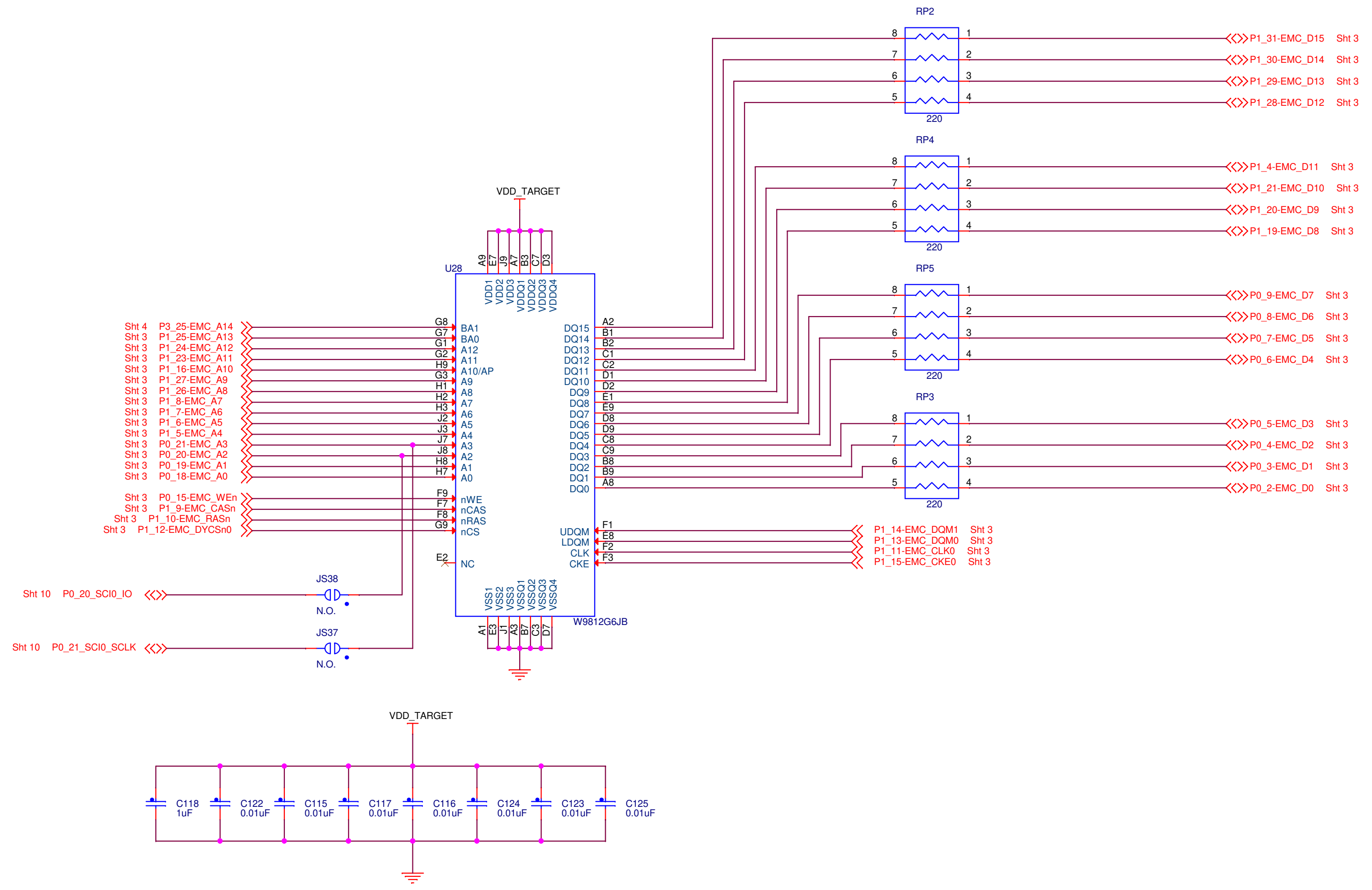

		411 E. Plumeria DR San Jose, CA 95134	
		<small>This document contains information proprietary to NXP and shall not be used for engineering design, procurement or manufacture in whole or in part without the express written permission of NXP Semiconductors.</small>	
ICAP Classification: CP: IUC: X PUBI:			
Designer: <Designer>	Drawing Title: <b>LPC546XX / LPC540XX BRD</b>		
Drawn by: <DrawnBy>	Page Title: <b>TARGET EMC_RAM</b>		
Approved: <Approver>	Size C	Document Number SCHM-LPC546/540XX	Rev E
Date: Monday, April 02, 2018		Sheet 5 of 13	

SPI / I2C header (PMOD compatible) Host interface

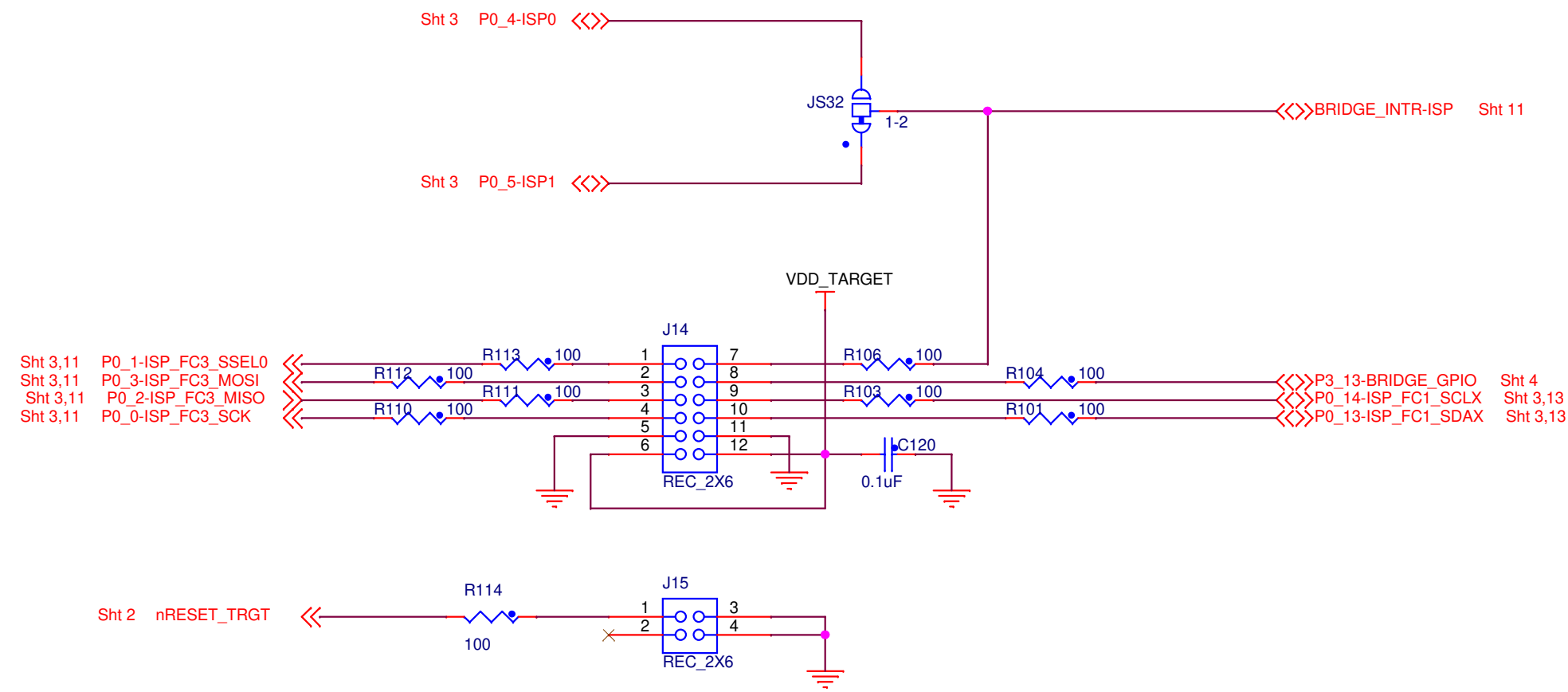

PMOD PIN FUNCTION

Pin 1: GPIO/SPI-SSEL(out)/UART-CTS(in)  
 Pin 2: GPIO/SPI-MOSI(out)/UART-TXD(out)  
 Pin 3: GPIO/SPI-MISO(in)/UART-RXD(in)  
 Pin 4: GPIO/SPI-SCK(out)/UART-RTS(out)  
 Pin 5: GND  
 Pin 6: VCC (3.3V)  
 Pin 7: GPIO/INT(in)  
 Pin 8: GPIO/RESET(out)  
 Pin 9: GPIO/SCL  
 Pin 10: GPIO/SDA  
 Pin 11: GND  
 Pin 12: VCC (3.3V)

LPC546xx/540xx supported function

Pin 1: GPIO/SPI-SSEL(out/in)  
 Pin 2: GPIO/SPI-MOSI(out/in)  
 Pin 3: GPIO/SPI-MISO(in/out)  
 Pin 4: GPIO/SPI-SCK(out/in)  
 Pin 5: GND  
 Pin 6: VCC (3.3V)  
 Pin 7: GPIO/INT(in/out)  
 Pin 8: GPIO/RESET(out)  
 Pin 9: SCL  
 Pin 10: SDA  
 Pin 11: GND  
 Pin 12: VCC (3.3V)

Accelerometer 3-axis

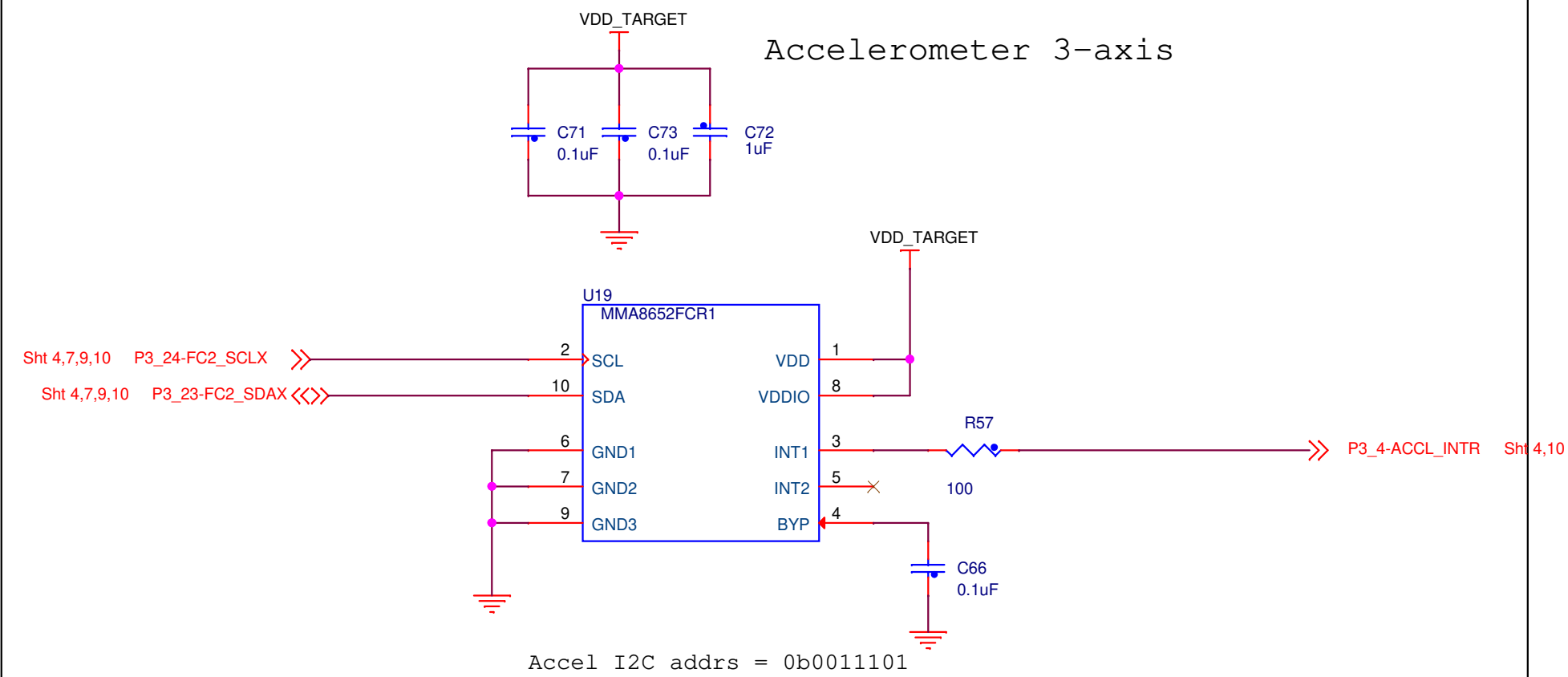

QSPI (SPIFI) NOR FLASH  
 S016 package / S08 package mutually exclusive

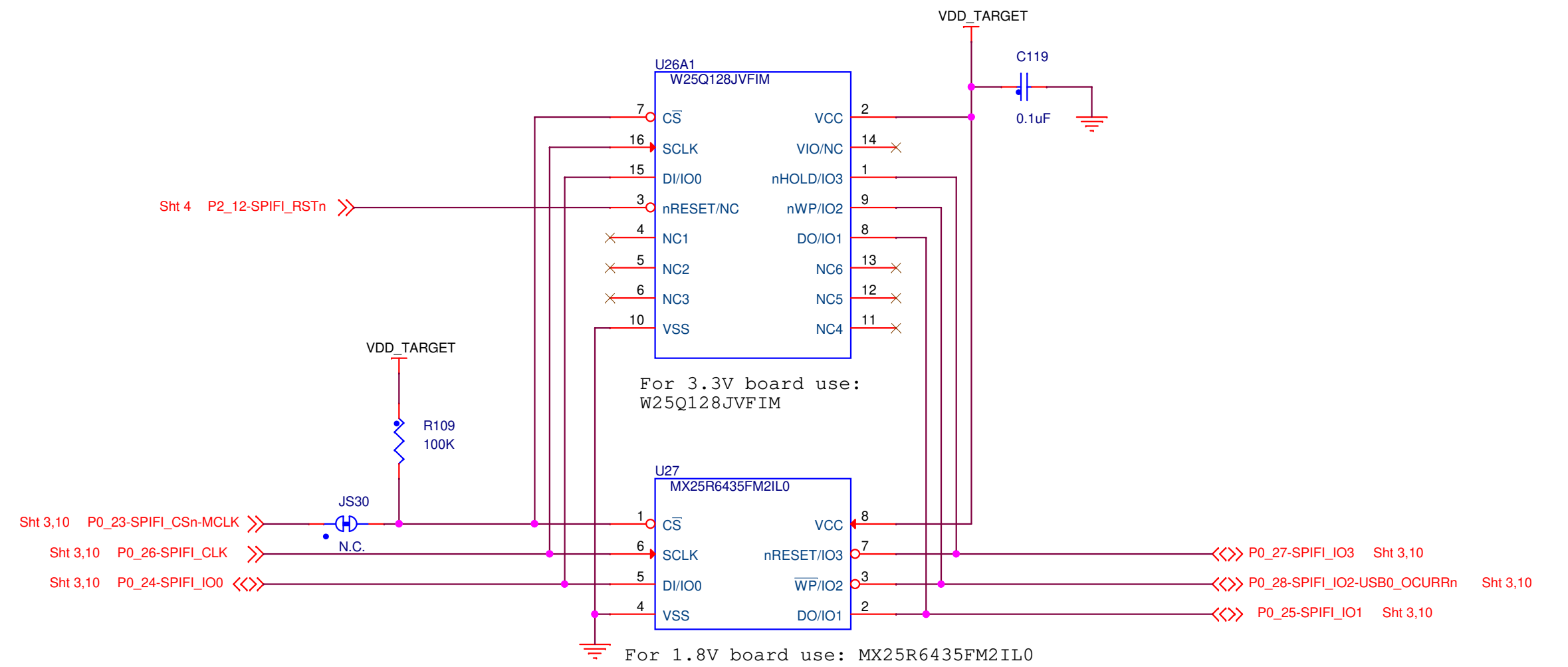

411 E. Plumeria DR  
 San Jose, CA 95134

This document contains information proprietary to NXP and shall not be used for engineering design, procurement or manufacture in whole or in part without the express written permission of NXP Semiconductors.

ICAP Classification: CP: IUC: X PUBI:	
Designer: <Designer>	Drawing Title: <b>LPC546XX / LPC540XX BRD</b>
Drawn by: <DrawnBy>	Page Title: <b>PMOD / SPIFI FLASH / ACCELEROMETER</b>
Approved: <Approver>	Size C Document Number SCHM-LPC546/540XX Rev E
Date: Monday, April 02, 2018	Sheet 6 of 13

### RK043FN02H-CT LCD display

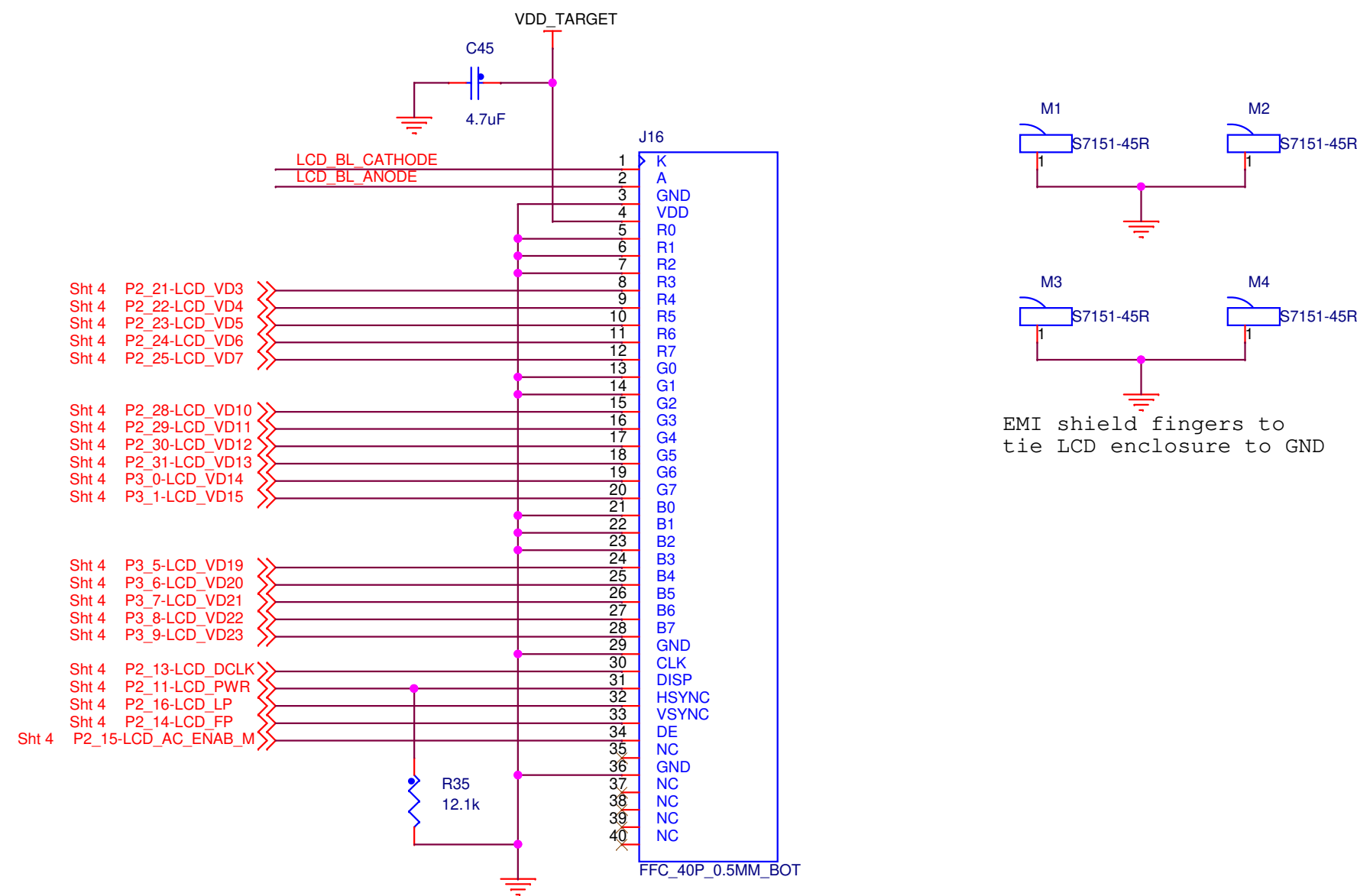

### Cap Touch RK043FN02H-CT LCD display

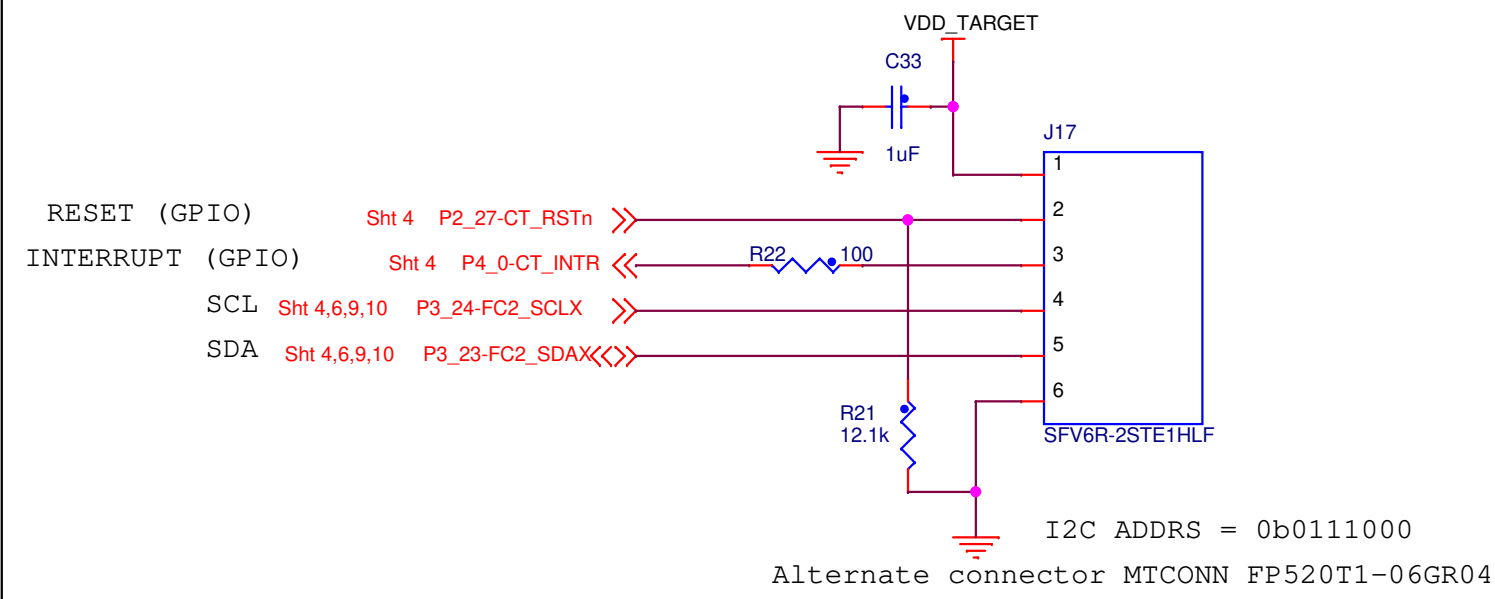

### SDIO SLOT

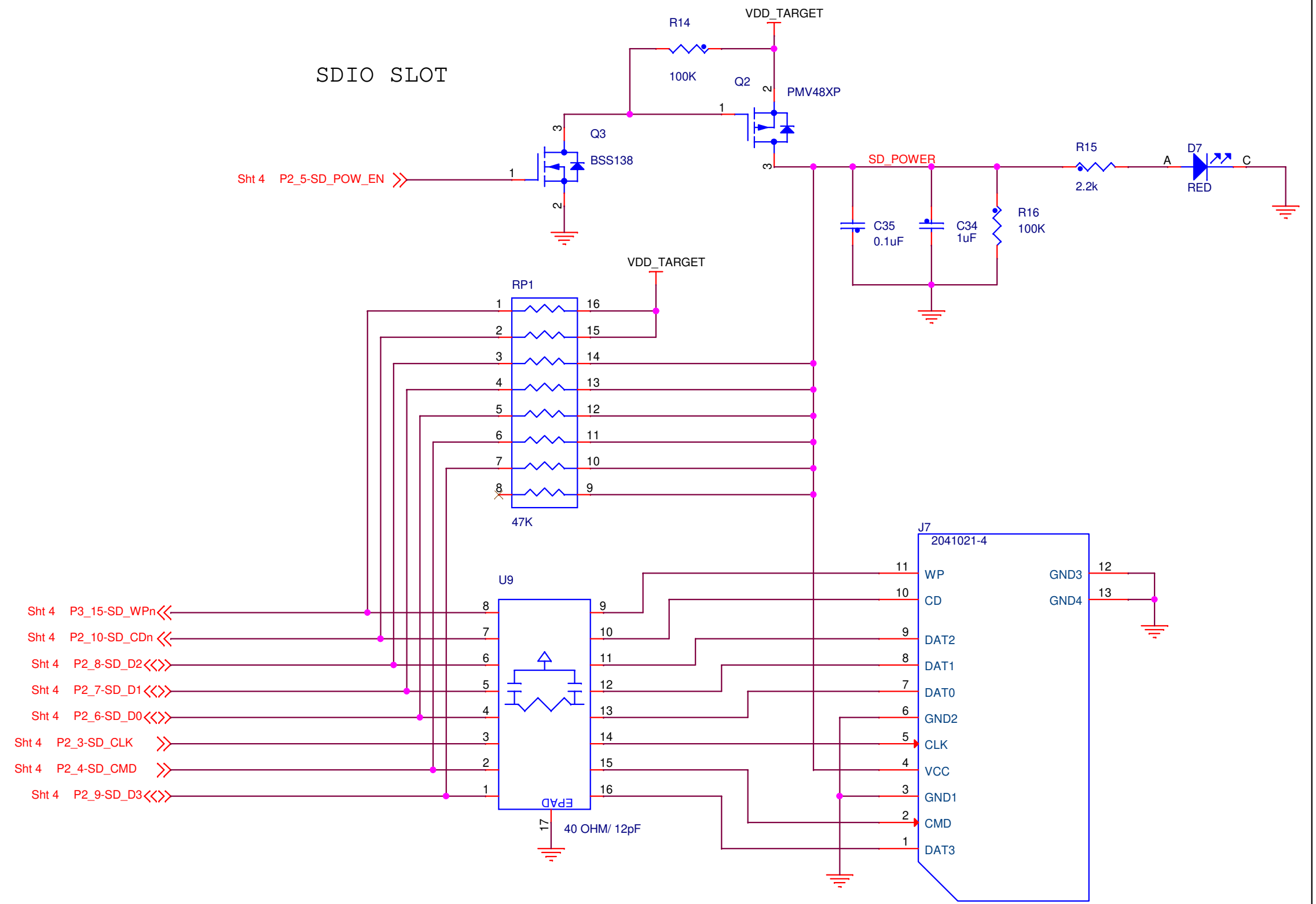

### LCD Backlight

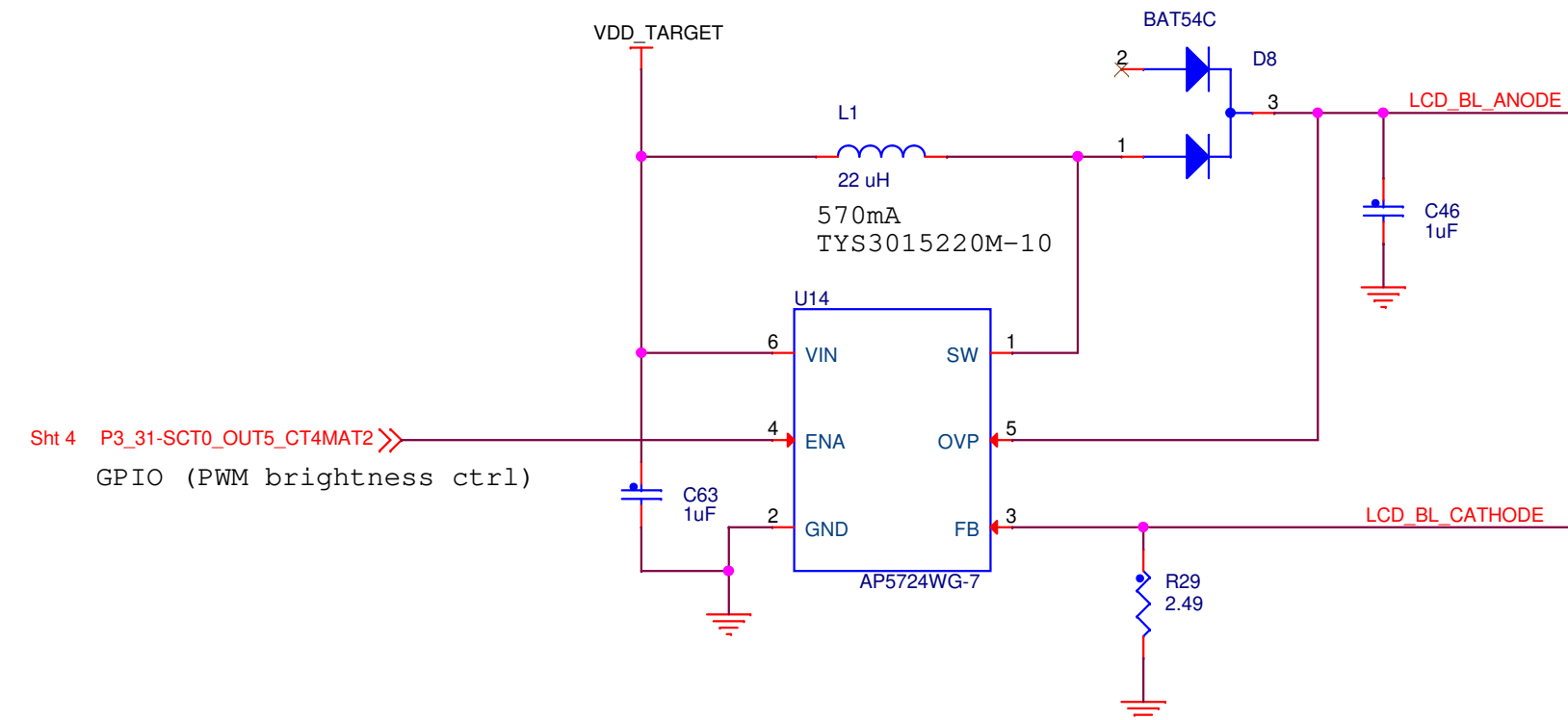

		411 E. Plumeria DR San Jose, CA 95134	
<small>This document contains information proprietary to NXP and shall not be used for engineering design, procurement or manufacture in whole or in part without the express written permission of NXP Semiconductors.</small>			
ICAP Classification: CP: IUC: X PUBI:			
Designer: <Designer>	Drawing Title: <b>LPC546XX / LPC540XX BRD</b>		
Drawn by: <DrawnBy>	Page Title: <b>LCD DISPLAY + CAP TOUCH / SD CARD SLOT</b>		
Approved: <Approver>	Size C	Document Number SCHM-LPC546/540XX	Rev E
Date: Monday, April 02, 2018	Sheet 7 of 13		

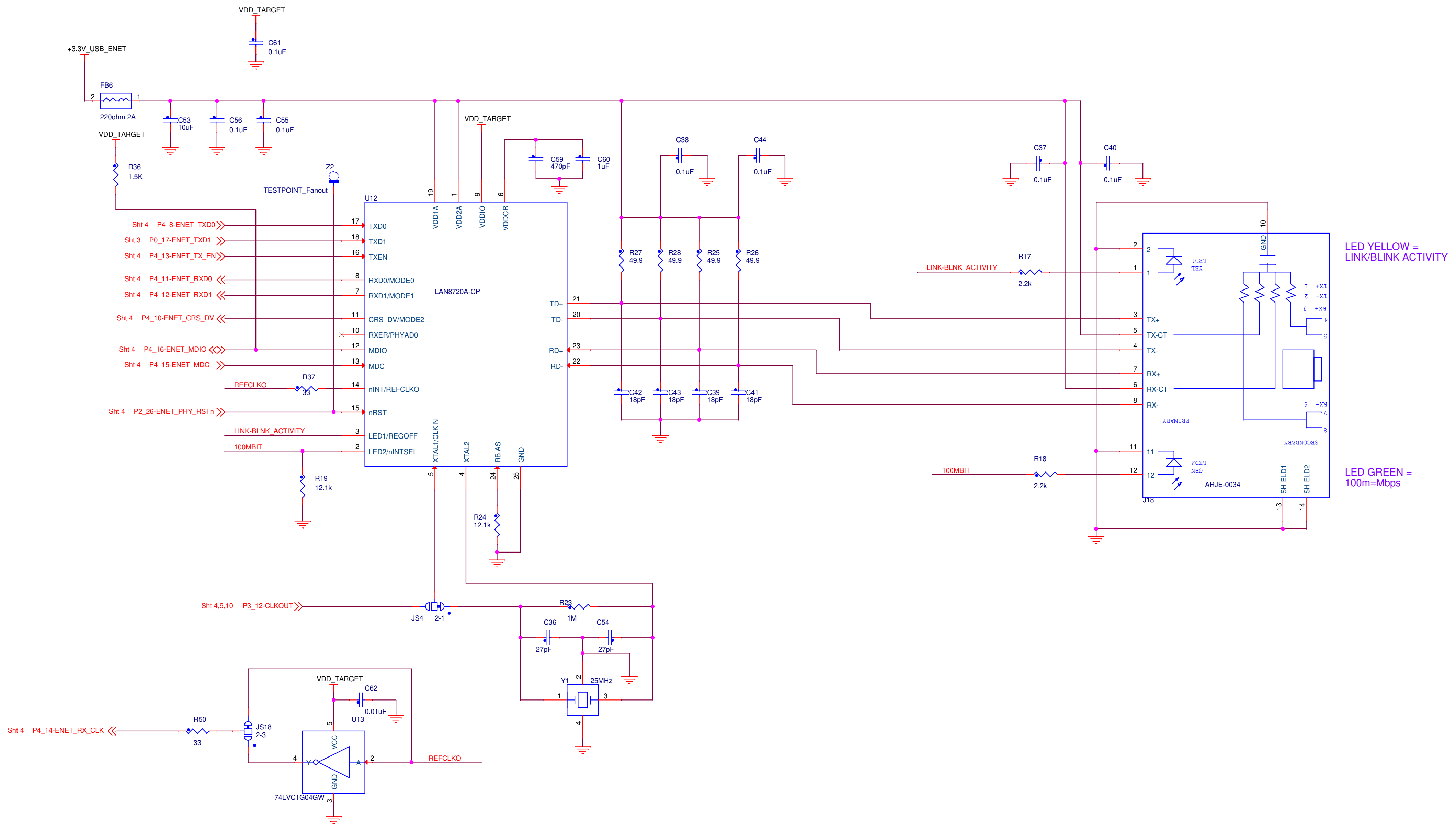

LED YELLOW =  
LINK/BLINK ACTIVITY

LED GREEN =  
100m=Mbps

		411 E. Plumeria DR San Jose, CA 95134	
This document contains information proprietary to NXP and shall not be used for engineering design, procurement or manufacture in whole or in part without the express written permission of NXP Semiconductors.			
ICAP Classification: CP: IUC: X PUBI:			
Designer: <Designer>	Drawing Title: <b>LPC546XX / LPC540XX BRD</b>		
Drawn by: <DrawnBy>	Page Title: <b>ETHERNET PHY</b>		
Approved: <Approver>	Size C	Document Number SCHM-LPC546/540XX	Rev E
Date: Monday, April 02, 2018		Sheet 8 of 13	



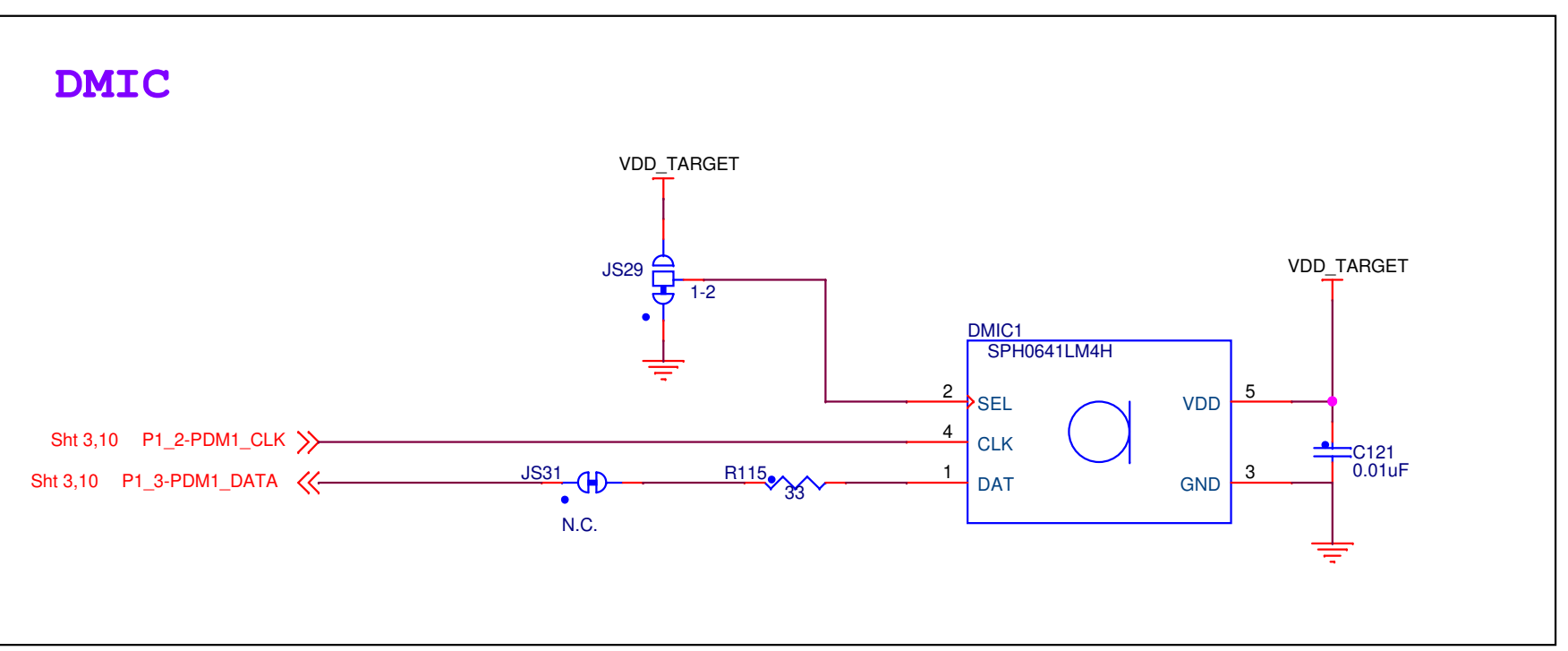
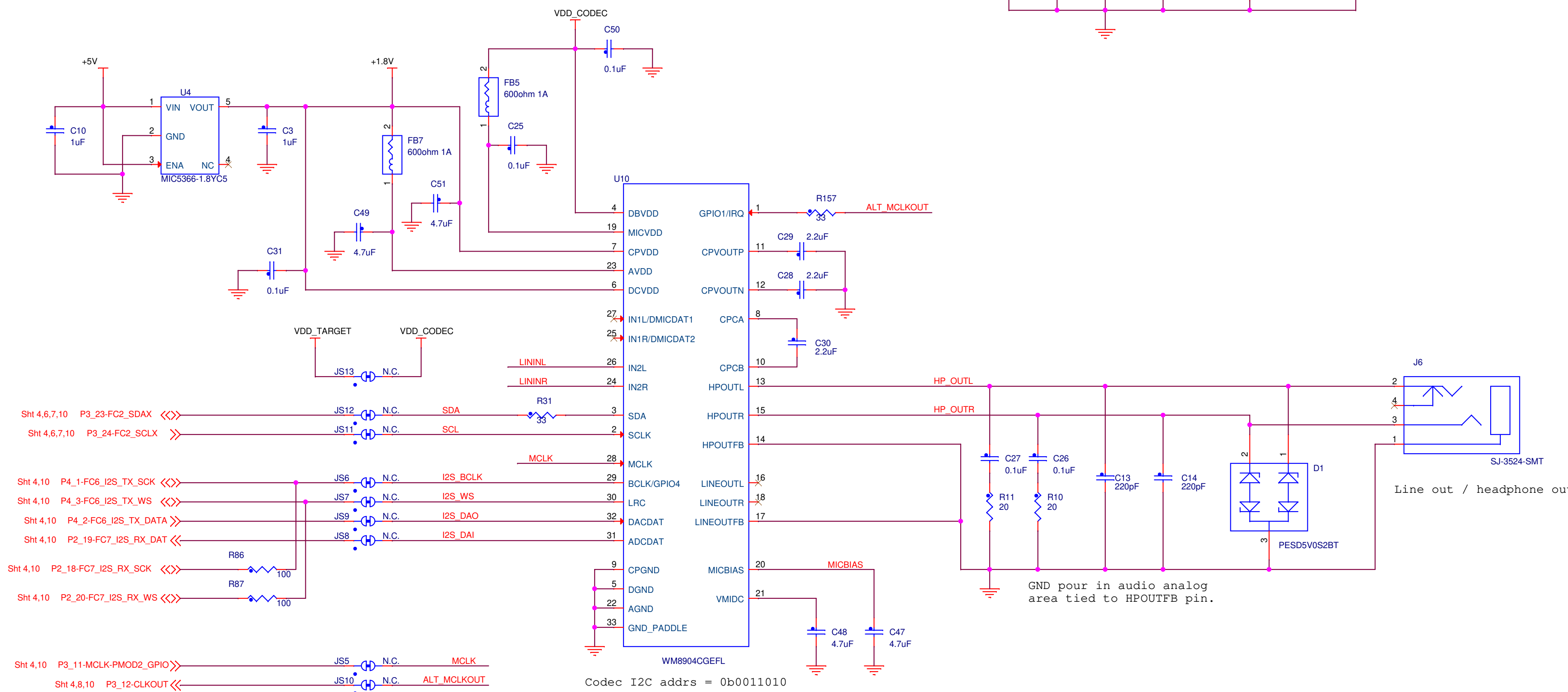

		411 E. Plumeria DR San Jose, CA 95134	
		This document contains information proprietary to NXP and shall not be used for engineering design, procurement or manufacture in whole or in part without the express written permission of NXP Semiconductors.	
ICAP Classification: CP: IUC: X PUBI:			
Designer: <Designer>	Drawing Title: <b>LPC546XX / LPC540XX BRD</b>		
Drawn by: <DrawnBy>	Page Title: <b>AUDIO CODEC / DMIC</b>		
Approved: <Approver>	Size C	Document Number SCHM-LPC546/540XX	Rev E
Date: Monday, April 02, 2018		Sheet 9 of 13	

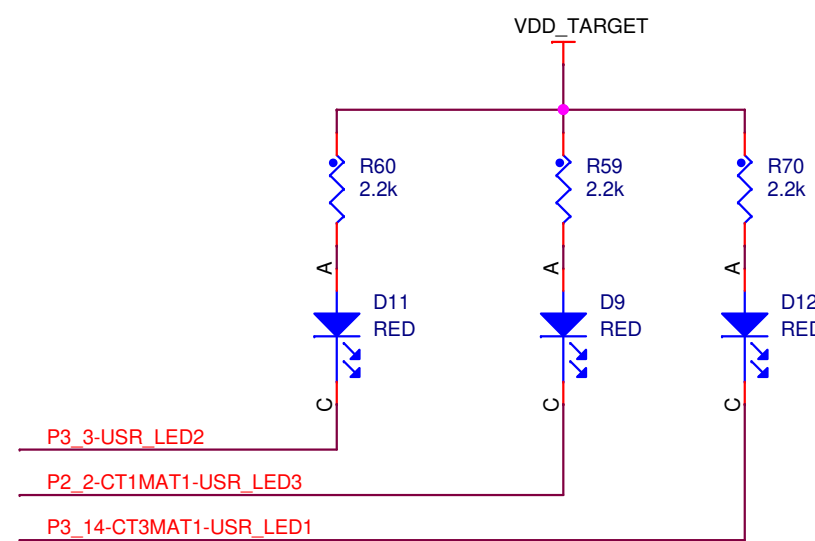
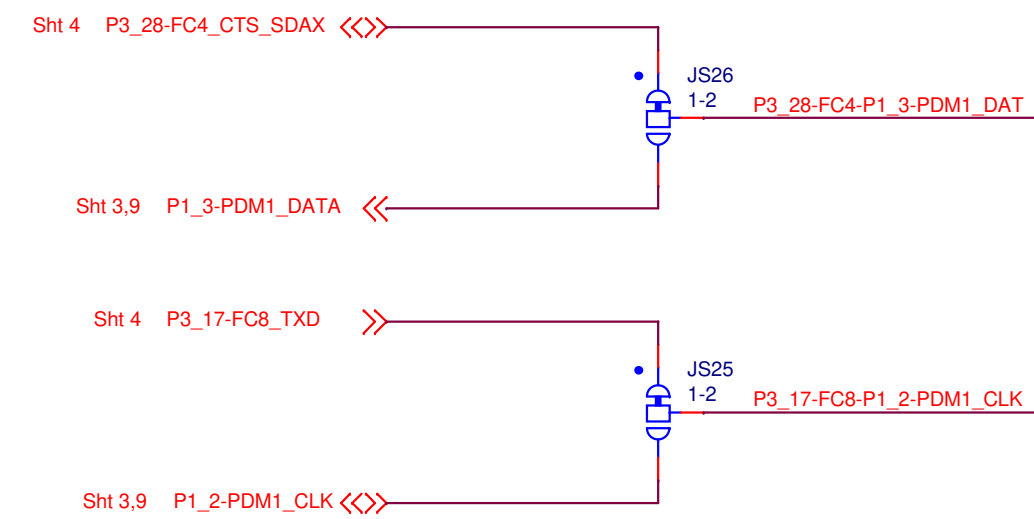
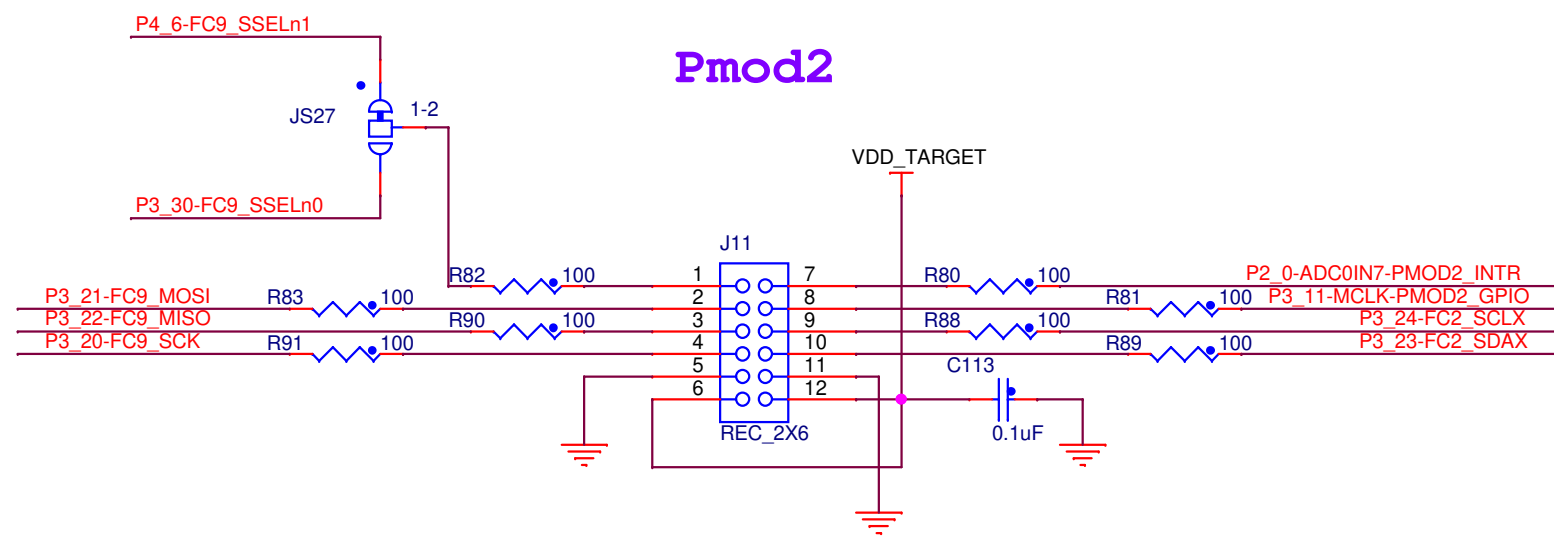
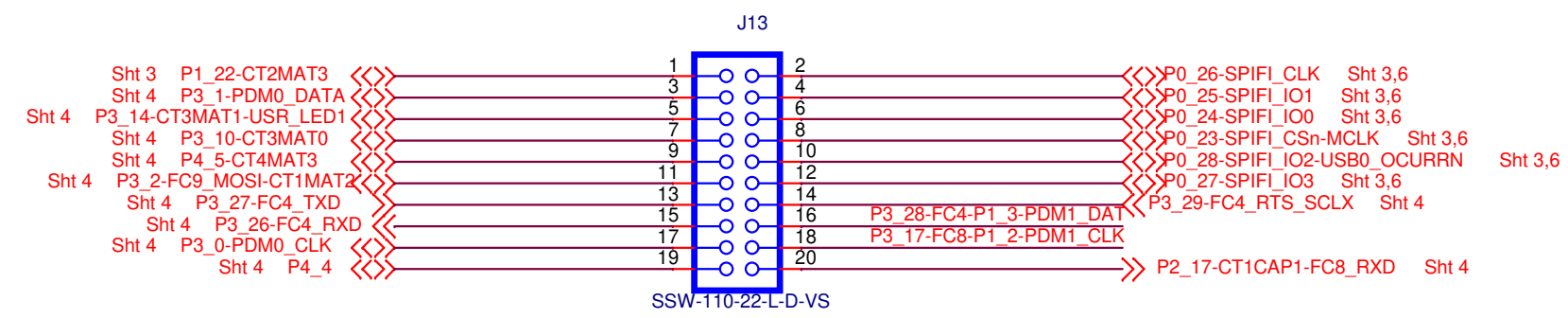
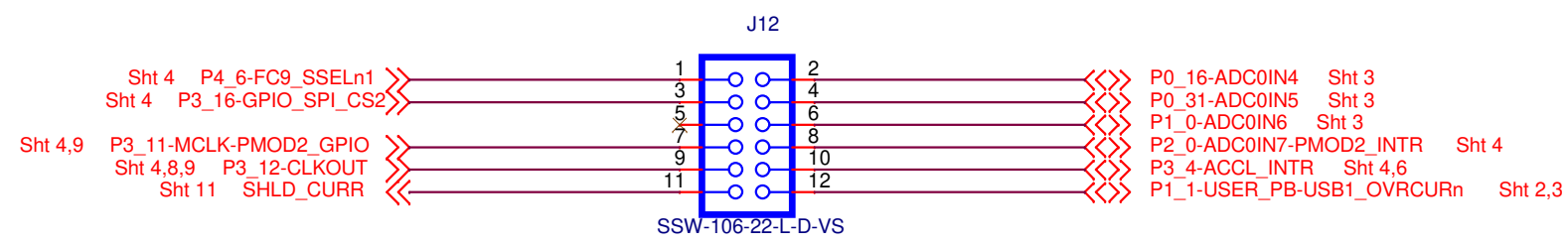
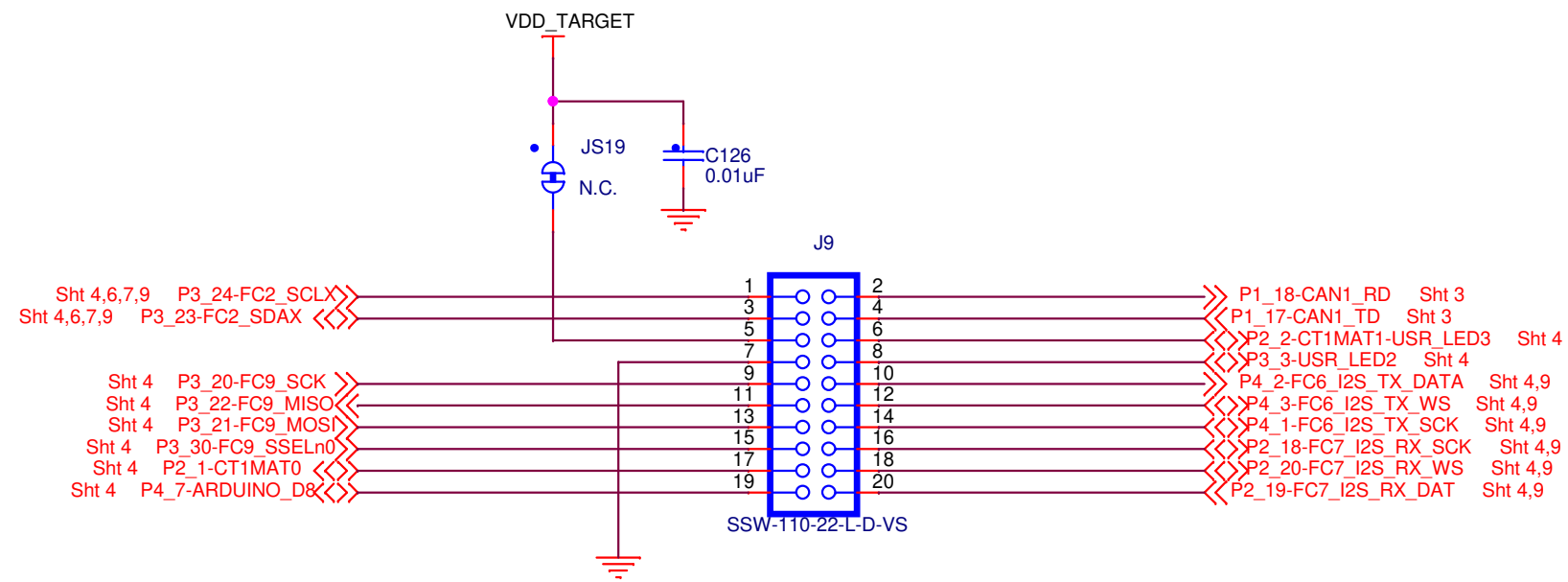
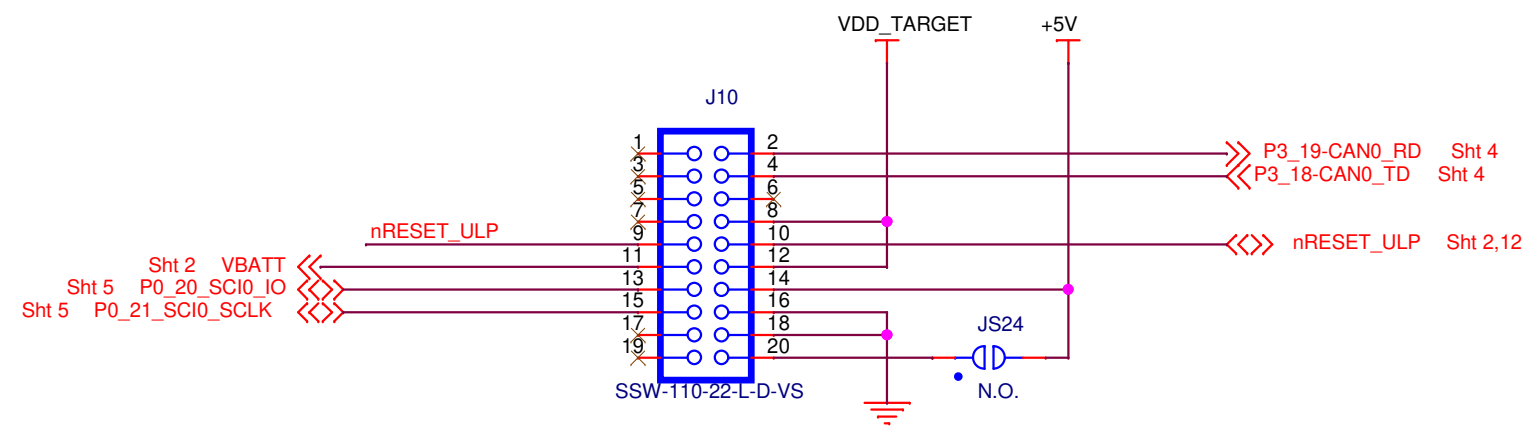
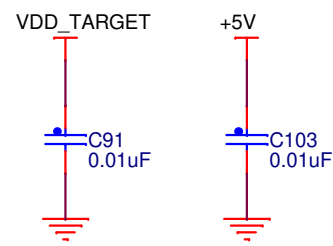

		411 E. Plumeria DR San Jose, CA 95134	
		This document contains information proprietary to NXP and shall not be used for engineering design, procurement or manufacture in whole or in part without the express written permission of NXP Semiconductors.	
ICAP Classification: CP: IUC: X PUBI:		Designer: <Designer>	
Drawing Title:		<b>LPC546XX / LPC540XX BRD</b>	
Drawn by: <DrawnBy>		Page Title:	
Approved: <Approver>		<b>SHIELD CONN / PMOD2 / LEDS</b>	
Size C	Document Number SCHM-LPC546/540XX	Rev E	Date: Monday, April 02, 2018
Sheet 10 of 13		Date: Monday, April 02, 2018	

Short JP6 when using Pmod SPI interface or FC0 UART at P4 (FTDI)

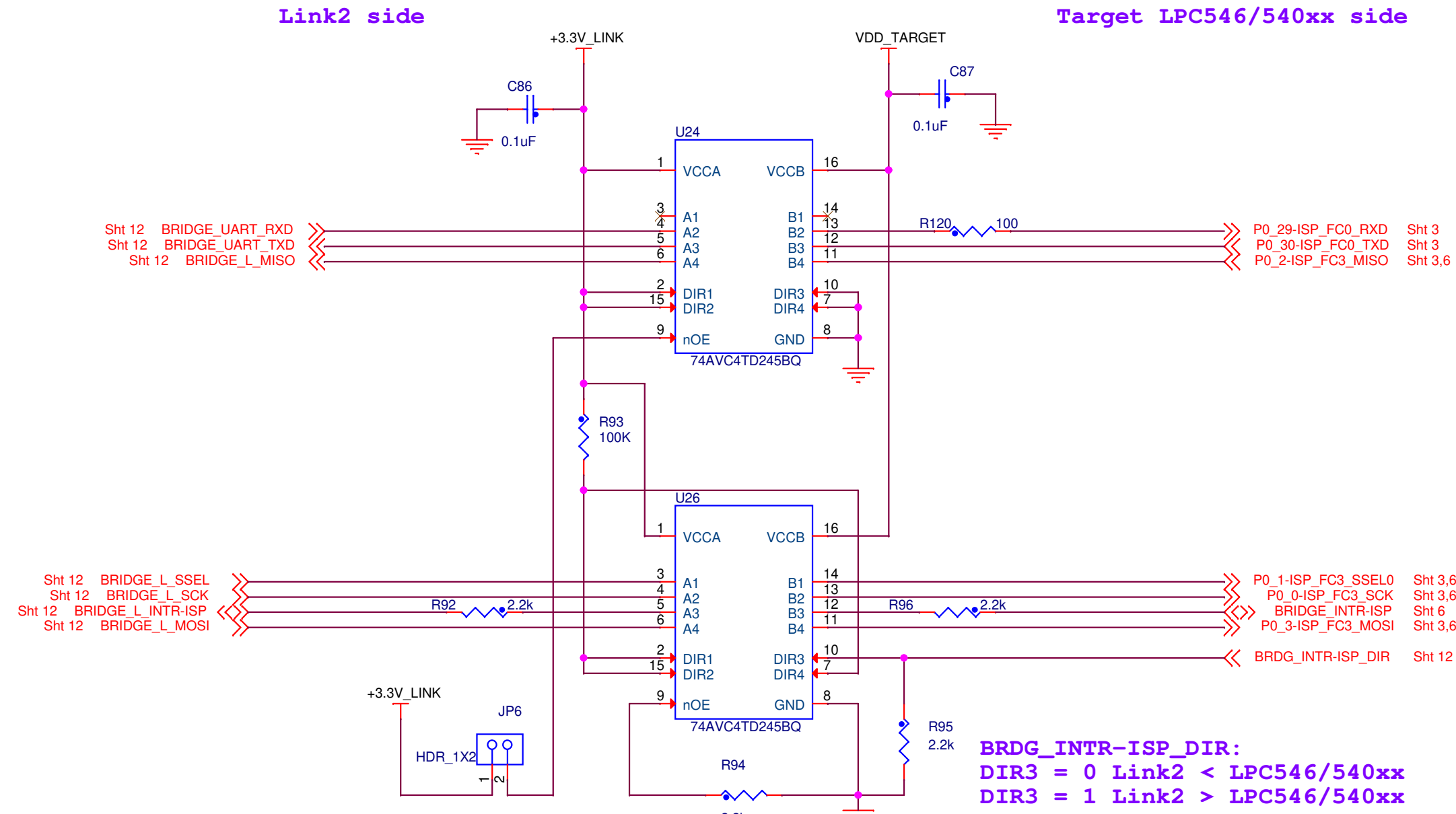

Short JP6 when using Pmod SPI interface or FC0 UART at P4 (FTDI)

BRDG\_INTR-ISP\_DIR:  
DIR3 = 0 Link2 < LPC546/540xx  
DIR3 = 1 Link2 > LPC546/540xx

LPC546XX/540XX VDD Core current measurement

LPC546XX/540XX				ADC122S021 12BIT ADC
Vsense (1) voltage 1-lsb	JP4.3-4 open LPC546xx LPC540xx	JP4.3-4 shunted LPC546xx LPC540xx	maximum current	ADC input 1-lsb 800uV
32uV	16uA minimum	32uA minimum	65mA	

(1) Vsense voltage is beteen U18 RS+ to RS-.  
The total Rvsense = R48 + (R49 || JP4.5-6).

JP4 3-4 setting

VDD LPC546XX LPC540XX	JP4 3-4	Total Rvsense (ohms)
3.3V	open	2
1.8V	shunted	1

Target LPC54xxx VDDC current measurement

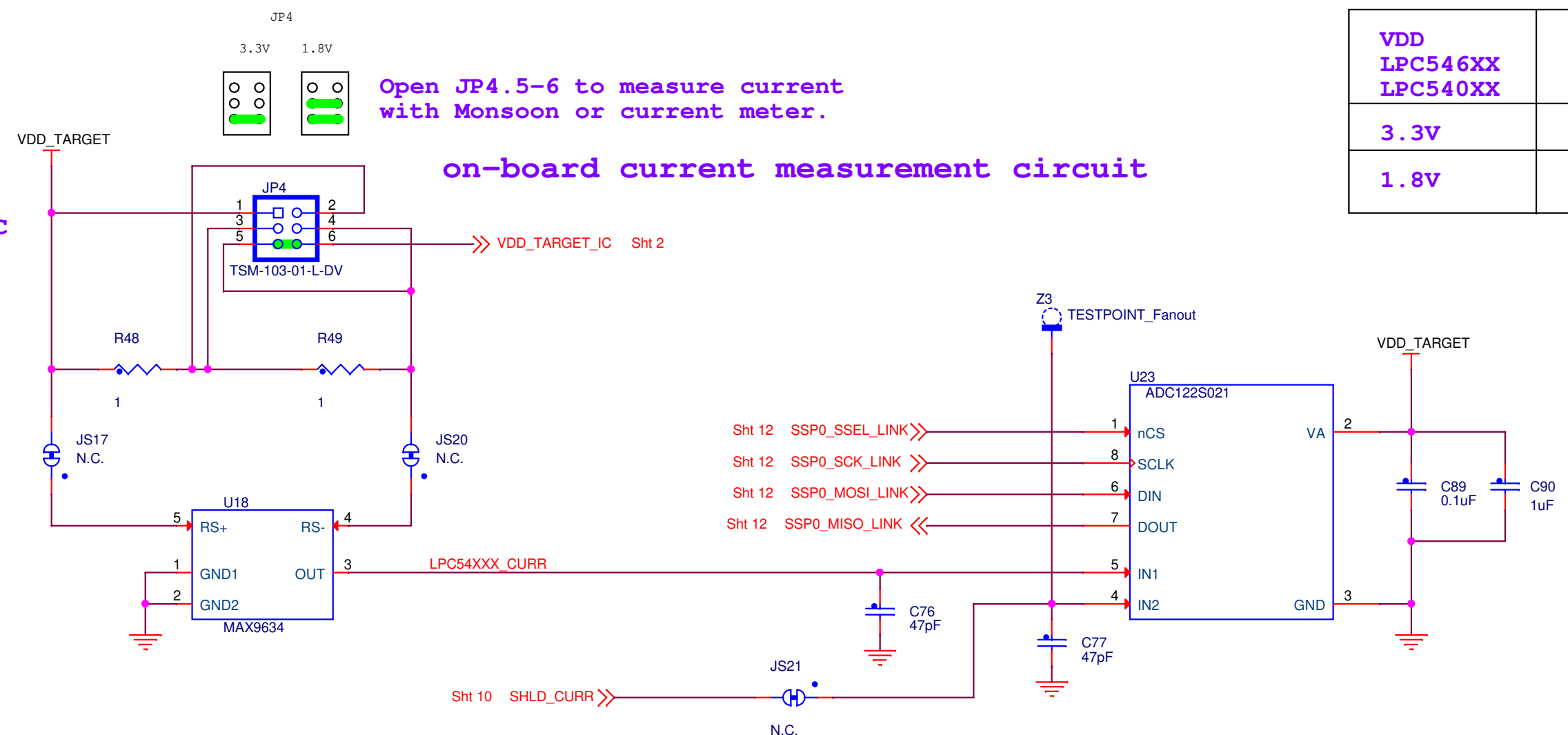

on-board current measurement circuit

Open JP4.5-6 to measure current with Monsoon or current meter.

		411 E. Plumeria DR San Jose, CA 95134	
This document contains information proprietary to NXP and shall not be used for engineering design, procurement or manufacture in whole or in part without the express written permission of NXP Semiconductors.			
ICAP Classification: CP: IUC: X PUBI:			
Designer: <Designer>	Drawing Title: <b>LPC546XX / LPC540XX BRD</b>		
Drawn by: <DrawnBy>	Page Title: <b>LPC54XX/540XX CURRENT MONITOR / LINK2 BRIDGE</b>		
Approved: <Approver>	Size C	Document Number SCHM-LPC546/540XX	Rev E
Date: Tuesday, April 03, 2018		Sheet 11 of 13	

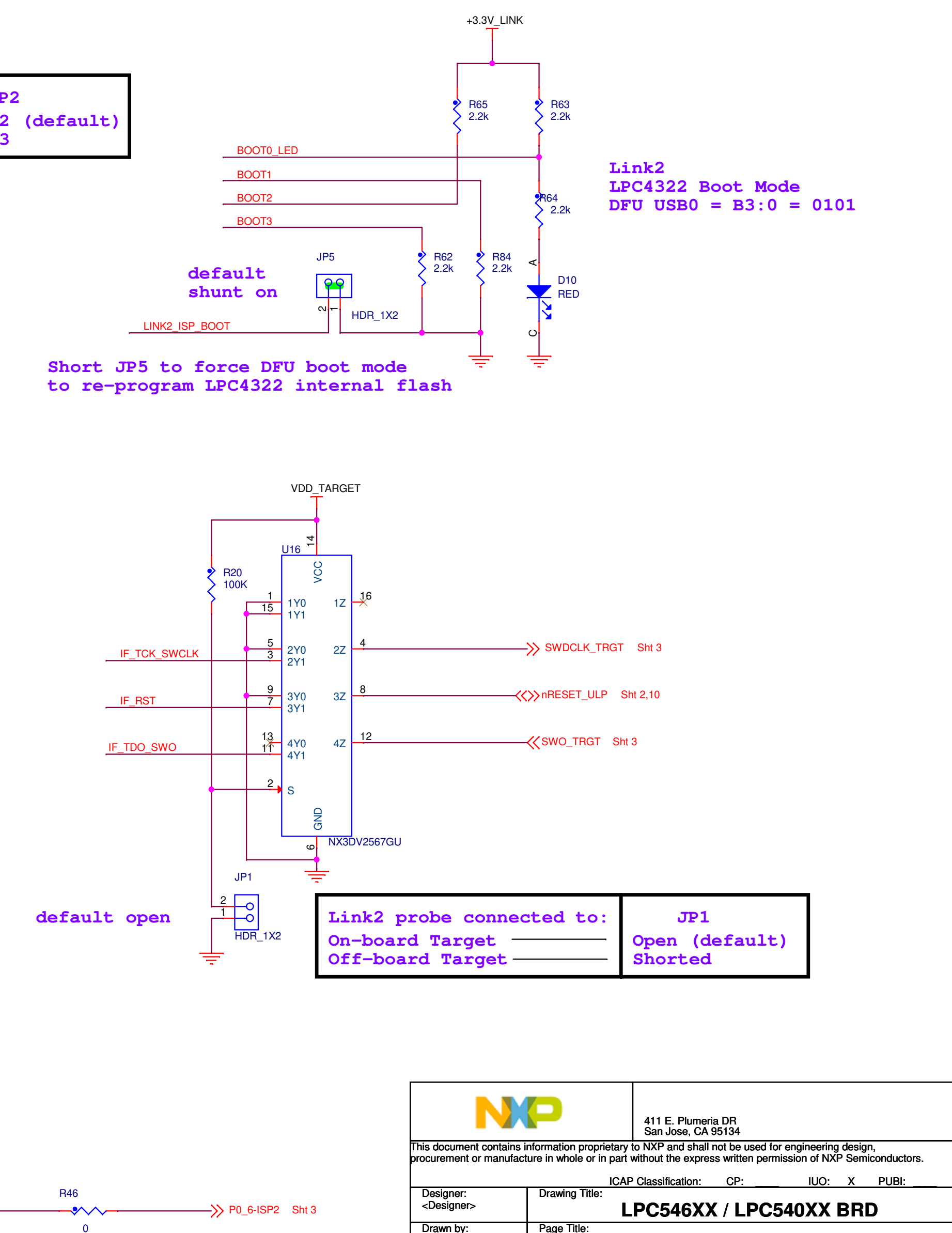
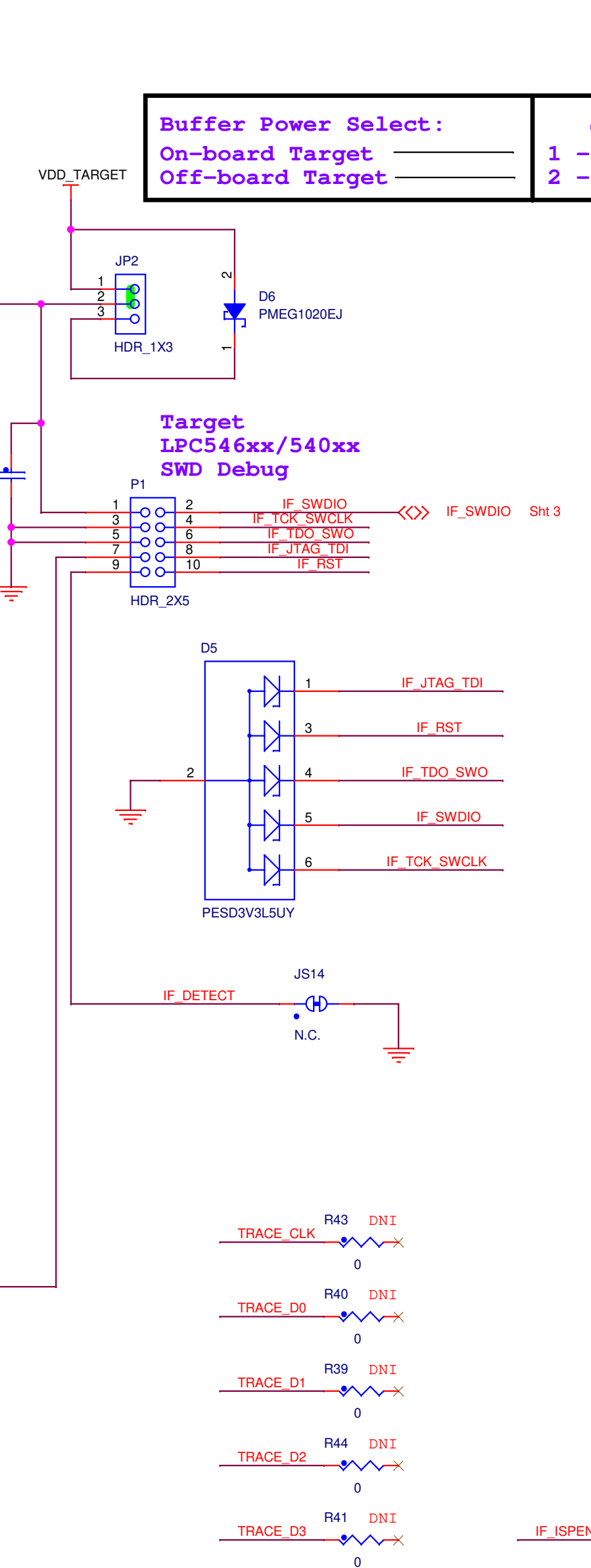
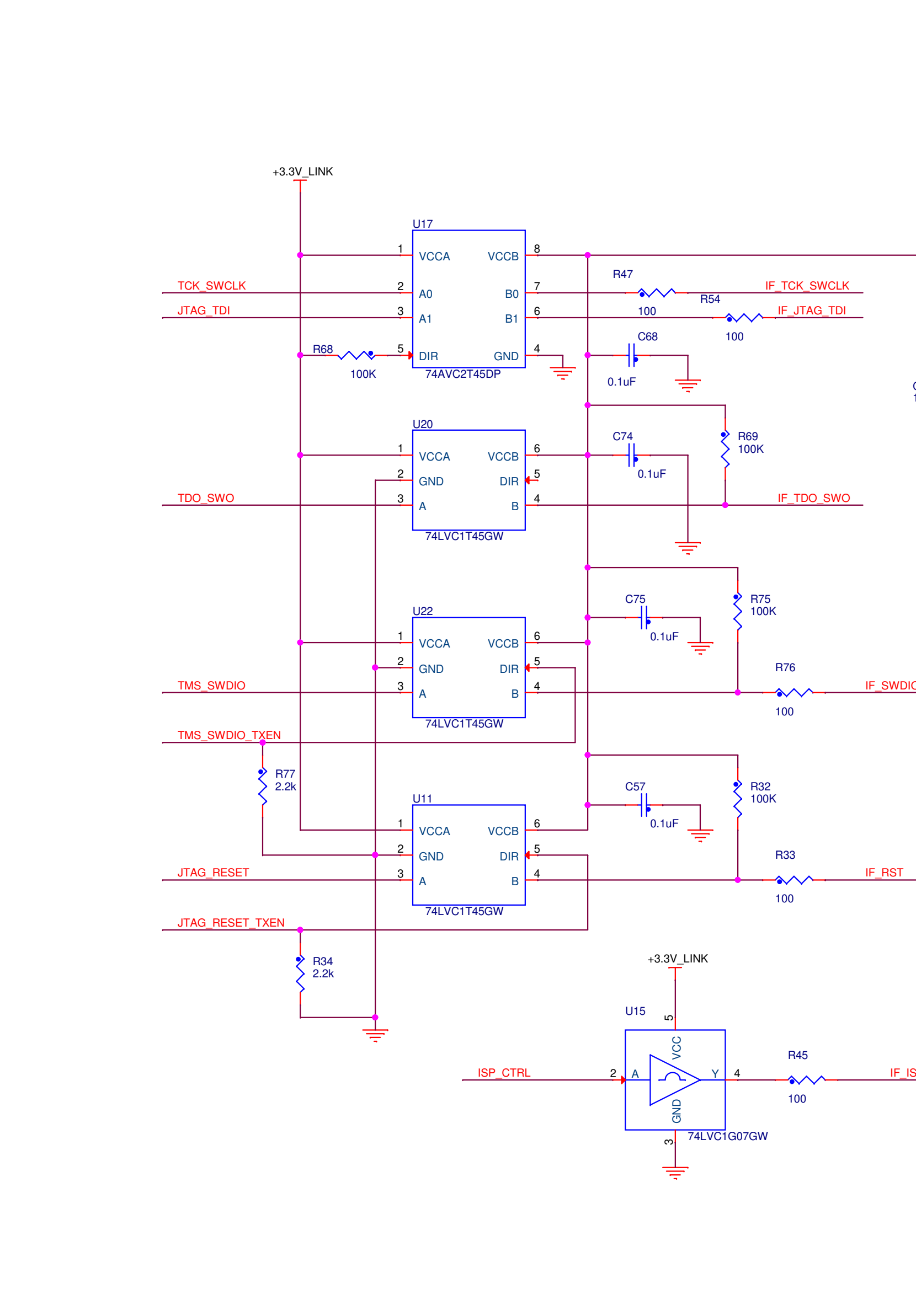
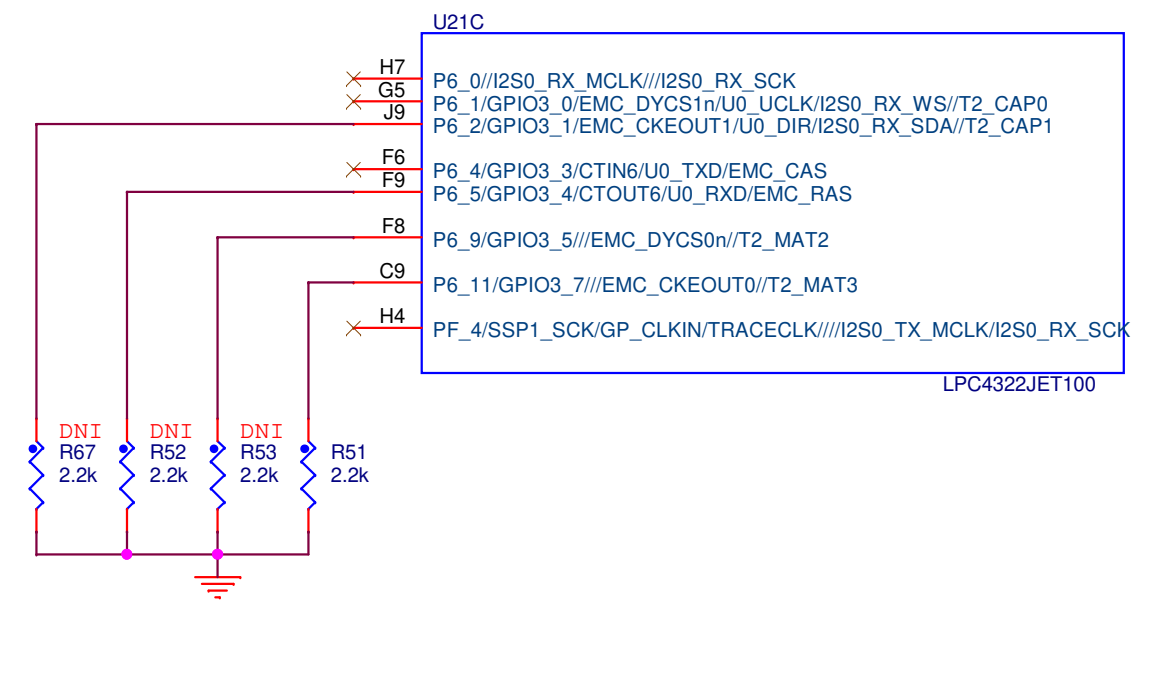
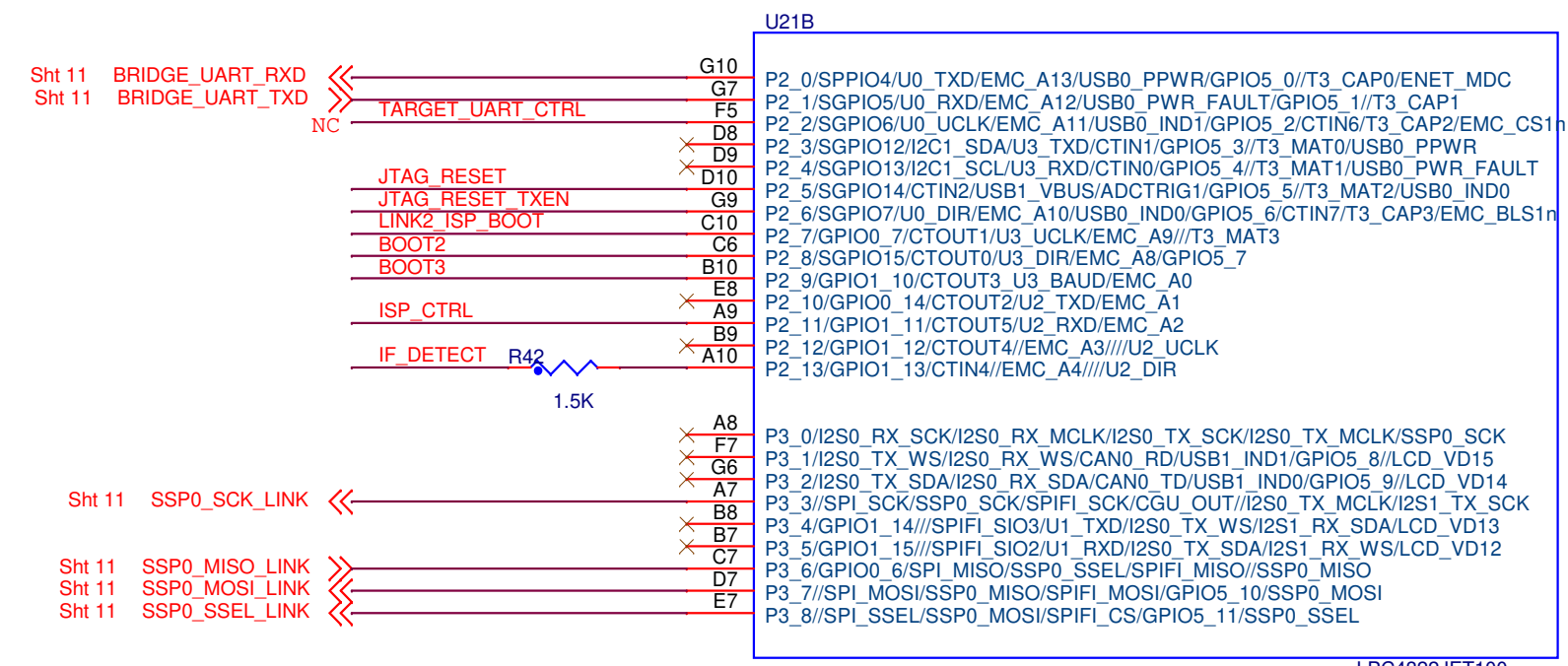
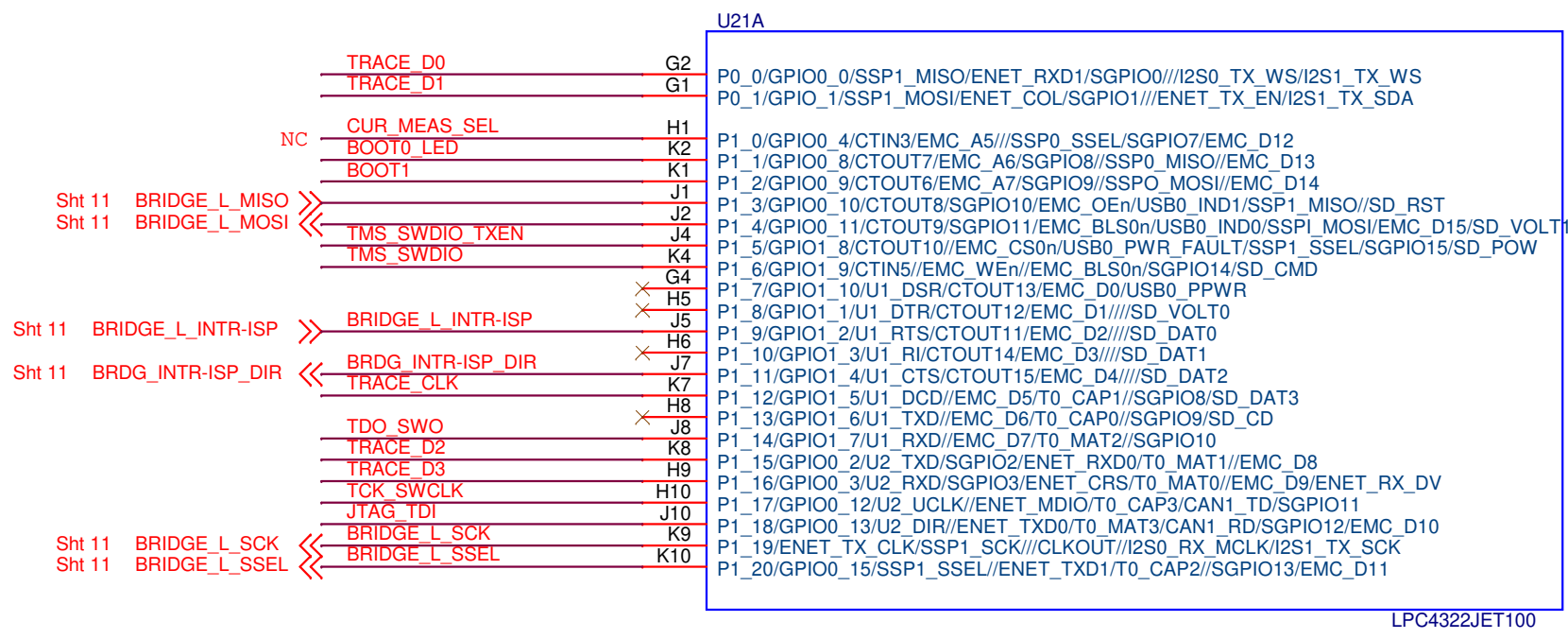

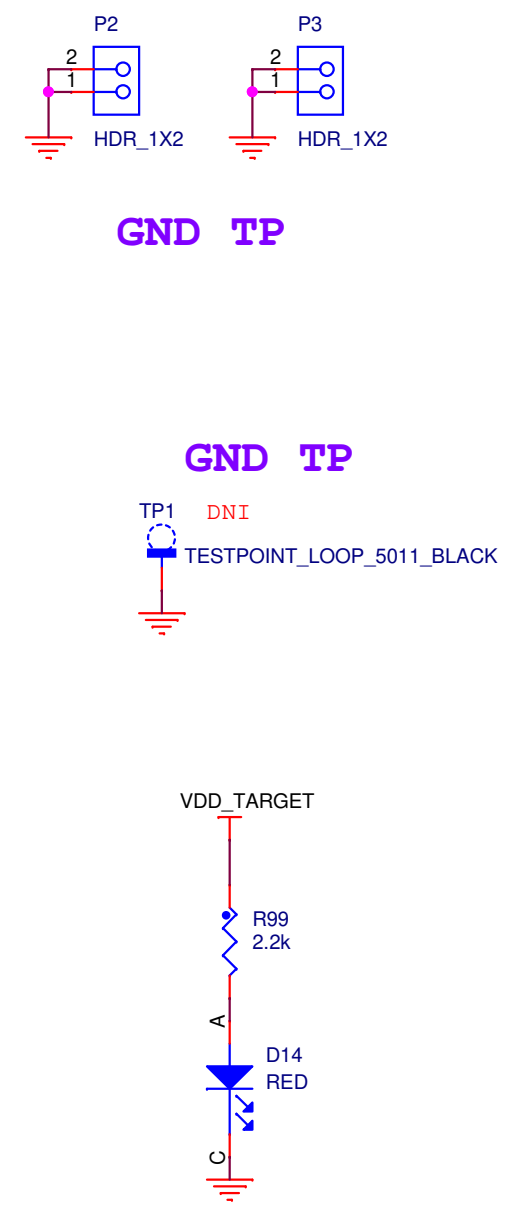
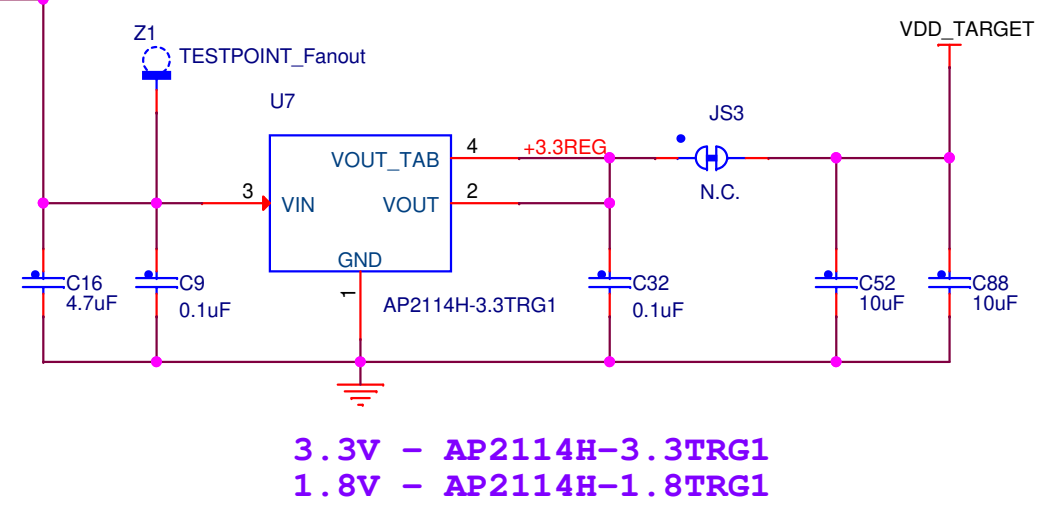
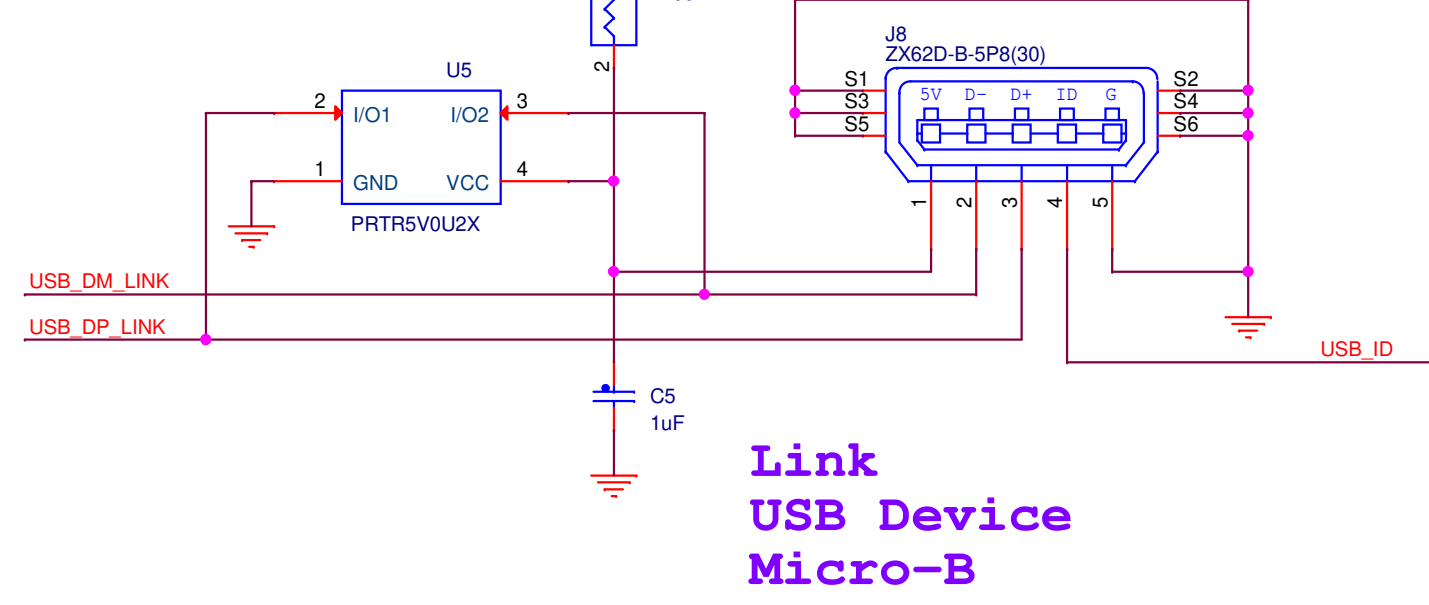
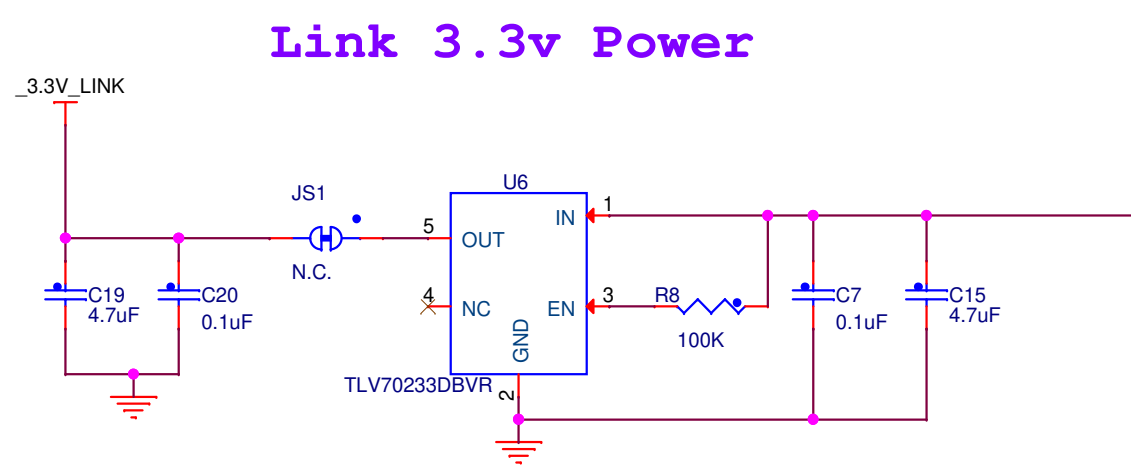
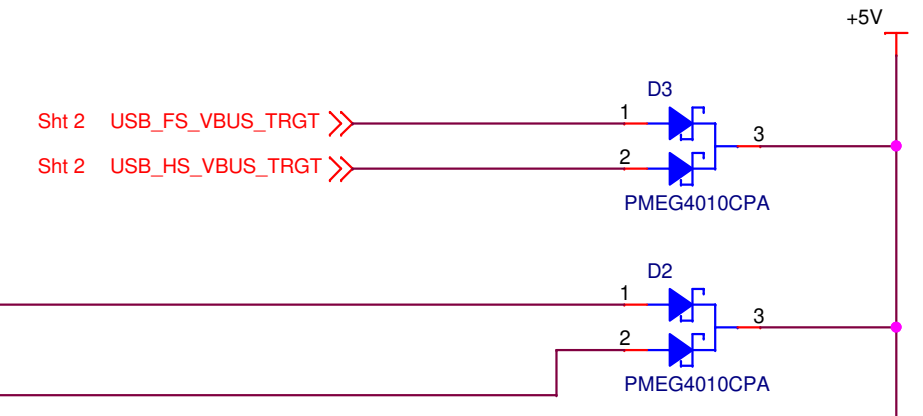
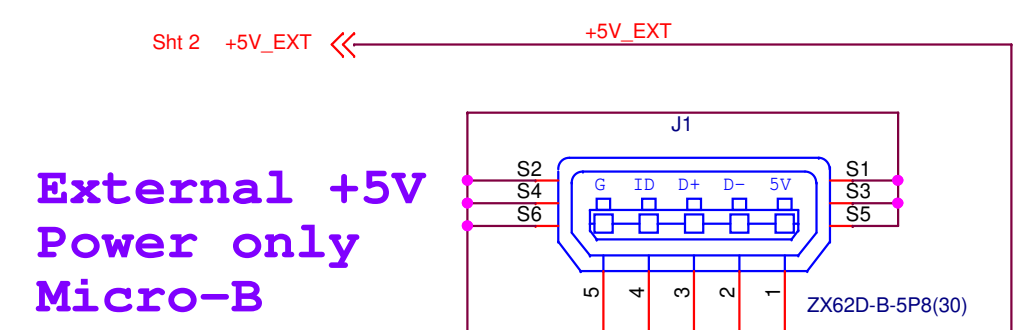
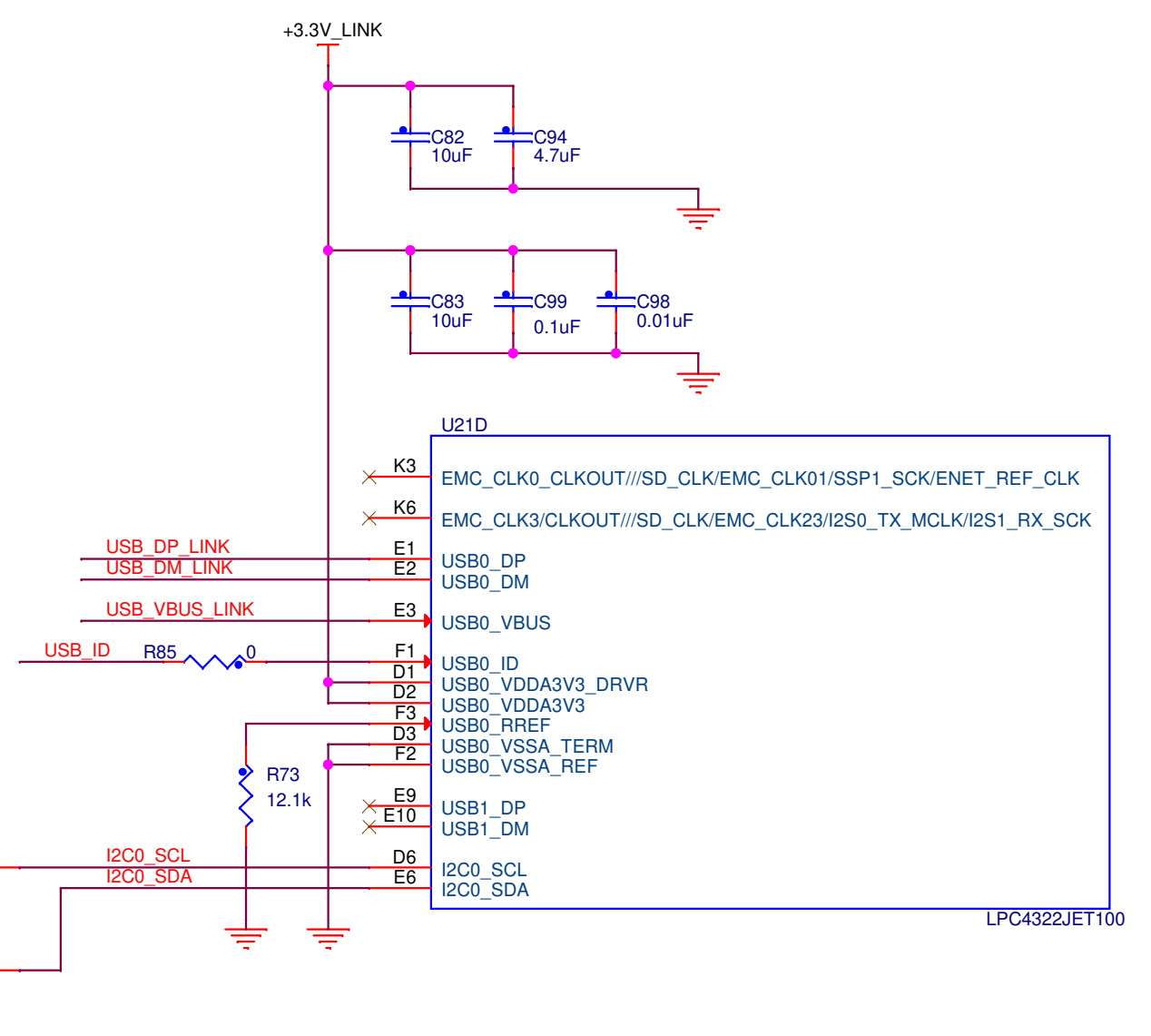
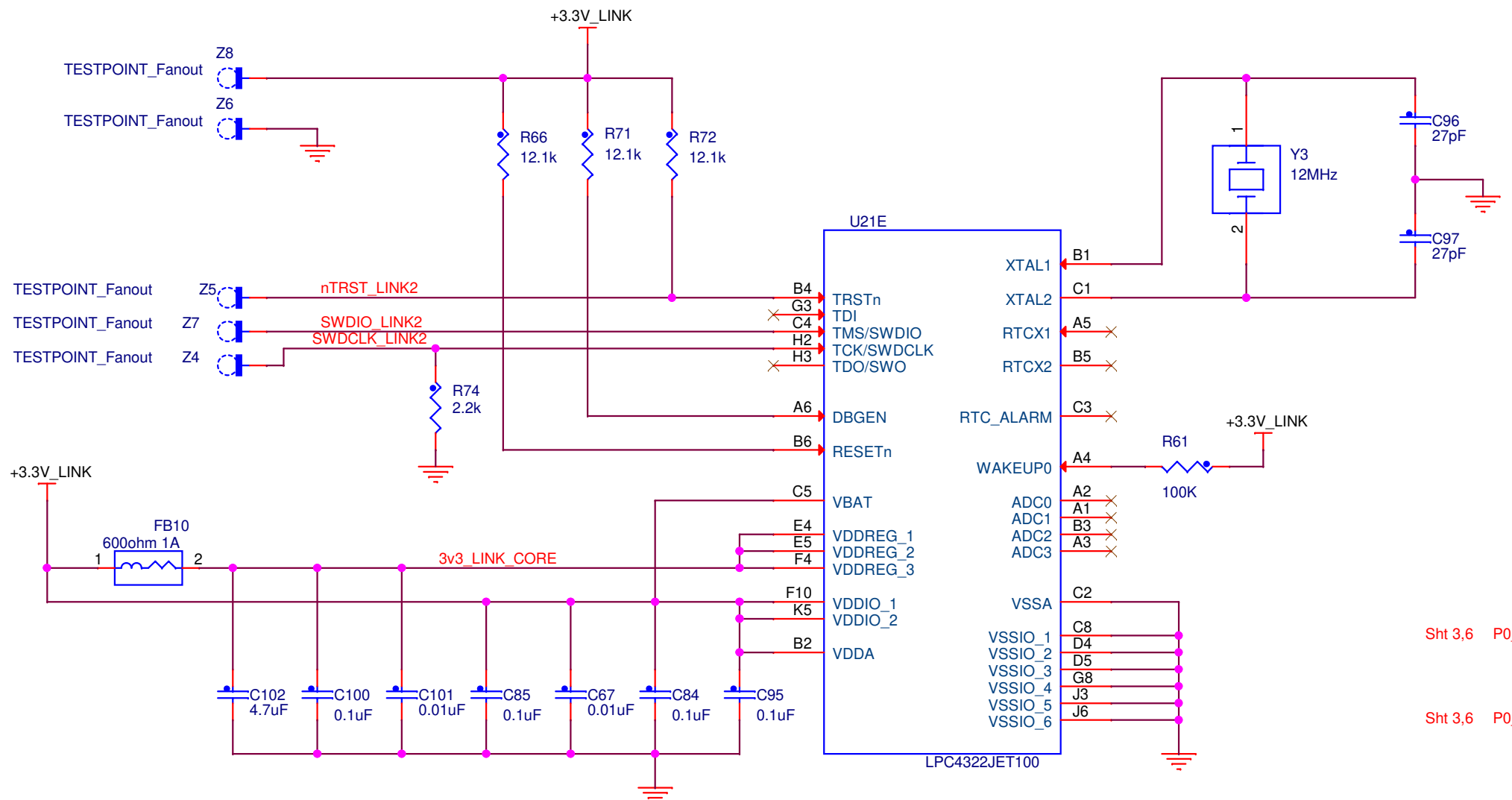

<b>NXP</b>		411 E. Plumeria DR San Jose, CA 95134	
This document contains information proprietary to NXP and shall not be used for engineering design, procurement or manufacture in whole or in part without the express written permission of NXP Semiconductors.			
ICAP Classification: CP: IUC: X PUBI:			
Designer: <Designer>	Drawing Title: <b>LPC546XX / LPC540XX BRD</b>		
Drawn by: <DrawnBy>	Page Title: <b>LINK2 LPC4322 / LINK2 USB / BOARD POWER</b>		
Approved: <Approver>	Size C	Document Number SCHM-LPC546/540XX	Rev E
Date: Monday, April 02, 2018	Sheet 13 of 13		