

NXP's Arm® Cortex®-M33 based LPC551x MCU Family Enhanced Security & Performance Efficiency

Justin Mortimer, Marketing Manager
Tomas Voda, System Engineer



SECURE CONNECTIONS
FOR A SMARTER WORLD

PUBLIC

NXP, THE NXP LOGO AND NXP SECURE CONNECTIONS FOR A SMARTER WORLD ARE TRADEMARKS OF NXP B.V.
ALL OTHER PRODUCT OR SERVICE NAMES ARE THE PROPERTY OF THEIR RESPECTIVE OWNERS. © 2020 NXP B.V.



Agenda

- Microcontroller Introduction
- Cortex-M33 based LPC5500 MCUs
- Security & Efficiency Benefits of LPC551x MCU Family

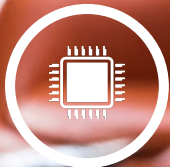

NXP Edge Processing Introduction



SECURE CONNECTIONS
FOR A SMARTER WORLD

PUBLIC

NXP, THE NXP LOGO AND NXP SECURE CONNECTIONS FOR A SMARTER WORLD ARE TRADEMARKS OF NXP B.V.
ALL OTHER PRODUCT OR SERVICE NAMES ARE THE PROPERTY OF THEIR RESPECTIVE OWNERS. © 2020 NXP B.V.



NXP'S EDGE PROCESSING LEADERSHIP

DIFFERENTIATED PLATFORMS ADDRESSING BROAD RANGE OF MARKET REQUIREMENTS

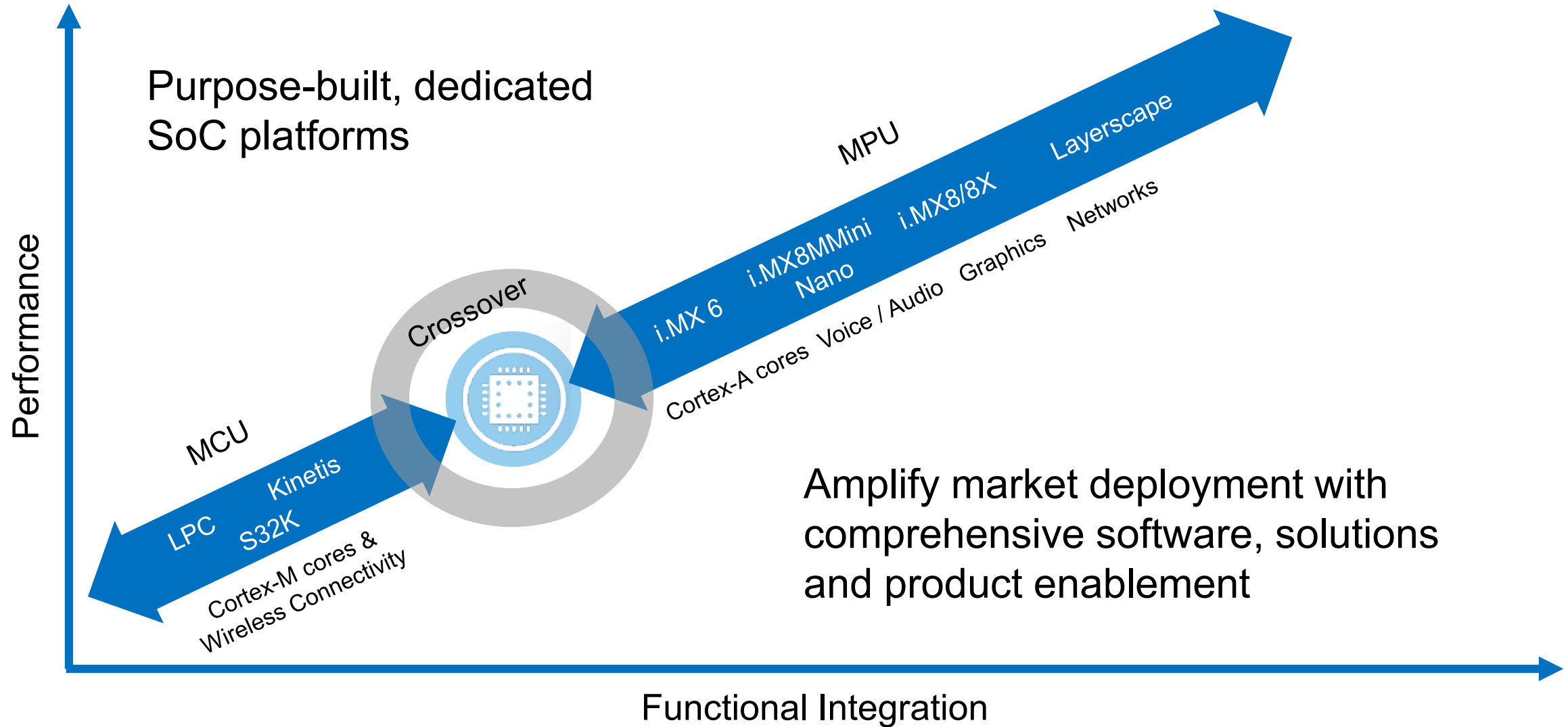



Industrial & IoT EDGE PROCESSING BUSINESS

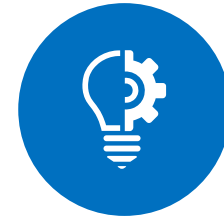

Product Innovation

High-performance crossover processors to Low-power secure and connected MCUs

Expansive Ecosystem

Common software platform combined with large partner network

Customer Driven Commitment

Total product quality, longevity and support for 10,000s end customers across thousands of diverse applications



Industrial & IoT MICROCONTROLLERS

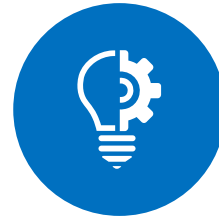

25K+ Customers



Numerous industry firsts

First Arm-based MCU, First Crossover MCU, First Cortex-M33 MCU, ...

46 Years in business

NXP MICROCONTROLLERS

SERVING NUMEROUS END MARKETS

Smart Home



White Goods



Consumer Products



Lifestyle Devices



Factory Automation & Building Control



Smart City Power & Energy



Secure Transactions



Compute & Gaming



NXP MICROCONTROLLER ECOSYSTEM

Online
Community

Online
Documentation

Online
SW & Tools

- Software compatibility across NXP's broad Cortex-M portfolio
- Cost effective evaluation boards with on-board debug probe and various expansion options

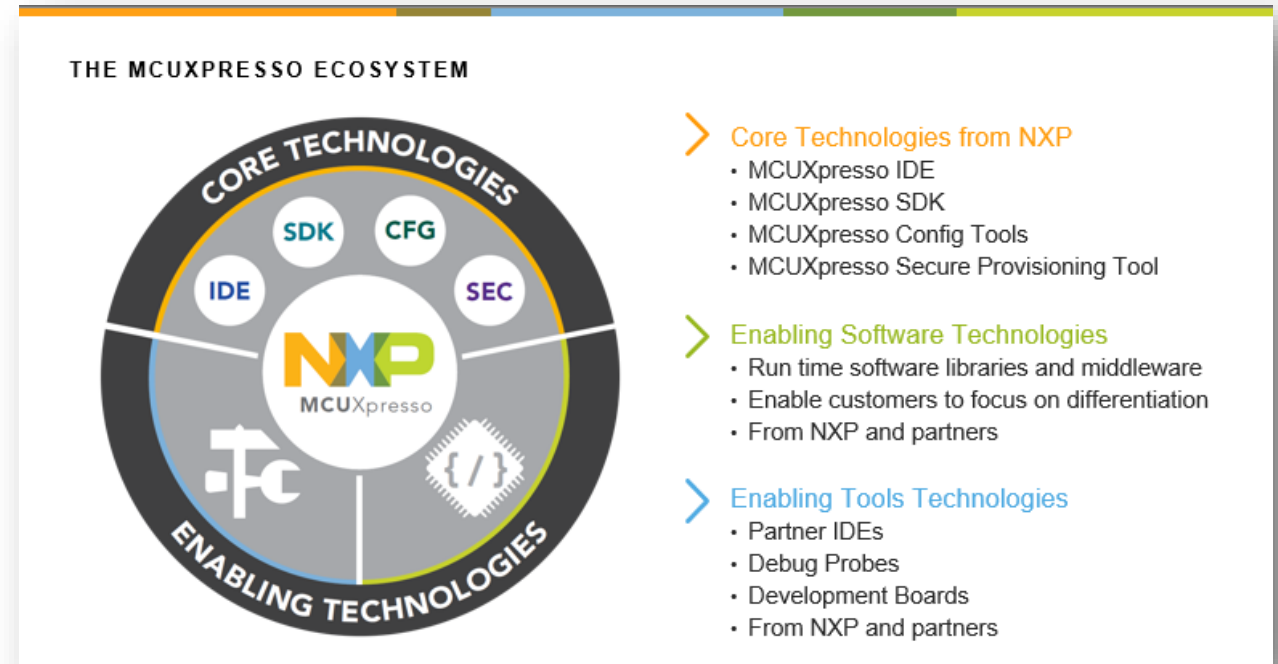
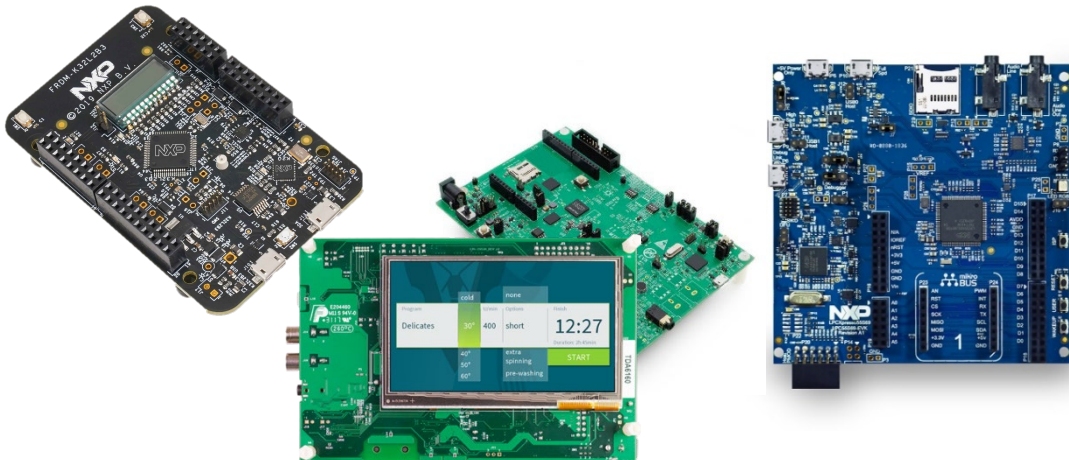

LONGEVITY EXTENDED TO 15 YEARS FOR OVER 1,000 MCU DEVICES



NXP has decades long experience and a longstanding track record of **providing continuity of production supply** of our MCU products.

Recently Extended:

- LPC5500 Series MCUs
- LPC54000 Series MCUs²
- LPC4300 Series MCUs
- LPC4000 Series MCUs
- LPC800 Series MCUs
- LPC1100 Series MCUs²
- LPC1800 Series MCUs
- i.MX RT1010 Crossover MCUs
- i.MX RT1015 Crossover MCUs
- i.MX RT1020 Crossover MCUs
- i.MX RT1050 Crossover MCUs
- i.MX RT1060 Crossover MCUs

Already extended to 15 years:

- KE Series
- KL Series
- KV Series
- KE Series
- KM Series
- LPC1700 Series
- LPC2000 Series

¹ Extension to 15 years starts from original date of launch. Visit www.nxp.com/productlongevity for the complete list and details.

² Extension excludes LPC11C22FBD48, LPC11C24FBD48, LPC54018JxM and LPC54S018JxM.





Arm Cortex-M33 **LPC5500 MCU** Spotlight

LPC5500 MCU Series

Single and dual-core Arm® Cortex®-M33 MCU Series

- Ultra-efficient 40nm flash technology
- Mixed-signal interfaces to sense, connect, control
- Enhanced safety and security
- IEC60730 library support for Smart Appliance and Safety applications.
- MCUXpresso developer ecosystem

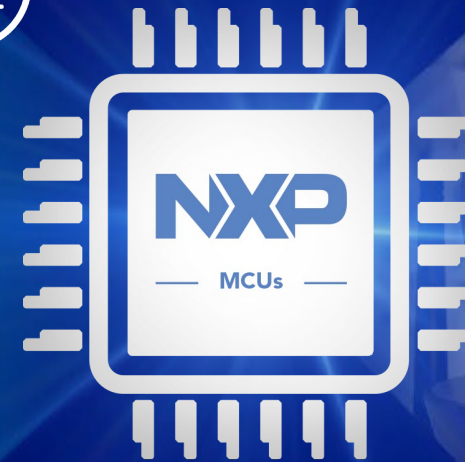

NXP.COM/LPC5500

NXP'S ARM® CORTEX®-M AND FOCUS MCU PORTFOLIO

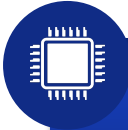

Performance & Integration

Cortex-M7 based **i.MX RT Crossover MCUs** for Ultimate Performance & Integration



Performance Efficiency

Cortex-M3/-M4 based MCUs and *introducing* **Cortex-M33 based LPC5500 MCU Series**



Power Efficient

Cortex-M0+ based MCUs and *introducing* **K32 L for Cost-, Power- sensitive use cases**



Value

S08 (8-bit) and LPC800 (Cortex-M0+) for Entry-level applications



Robust Industrial MCU

KE (Industrial) & S32K (Automotive) for Safe and Reliable 5V MCU Applications

DSC/KV for Motor Control & Digital Power & **KM** for Metering Applications

LPC5500 MCU SERIES

Key Features and Comparisons

- Nearly 20% performance improvement over Cortex-M4 based MCUs (over 60% vs Cortex-M0) with redesigned pipeline - up to two instructions per clock cycle

	Cortex-M0+	Cortex-M23	Cortex-M3	Cortex-M4	Cortex-M33
DMIPS/MHz	0.95	0.98	1.25	1.25	1.50
CoreMark®/MHz	2.46	2.50	3.32	3.40	4.02

- TrustZone for system-wide, secure resource isolation enabling trusted runtime execution and physical protection in embedded MCU applications
- Tightly coupled accelerators with coprocessor interface & extensions (Arm’s single precision FPU along with NXP accelerators)

Cortex-M4	Cortex-M33
	TrustZone
	Stack limit checking
	Co-processor interface
	Enhanced debug
	MTB
ETM	ETM
NVIC (max 240 IRQs)	NVIC (max 480 IRQs)
MPU (PMSAv7)	MPU (PMSAv8)
AHB Lite	AHB5
FPU	FPU
SIMD/ DSP	SIMD/ DSP
WIC	WIC
Serial wire / JTAG	Serial wire / JTAG
ARMv7-M	ARMv8-M mainline

■ New or updated

LPC5500 MCU SERIES ROADMAP

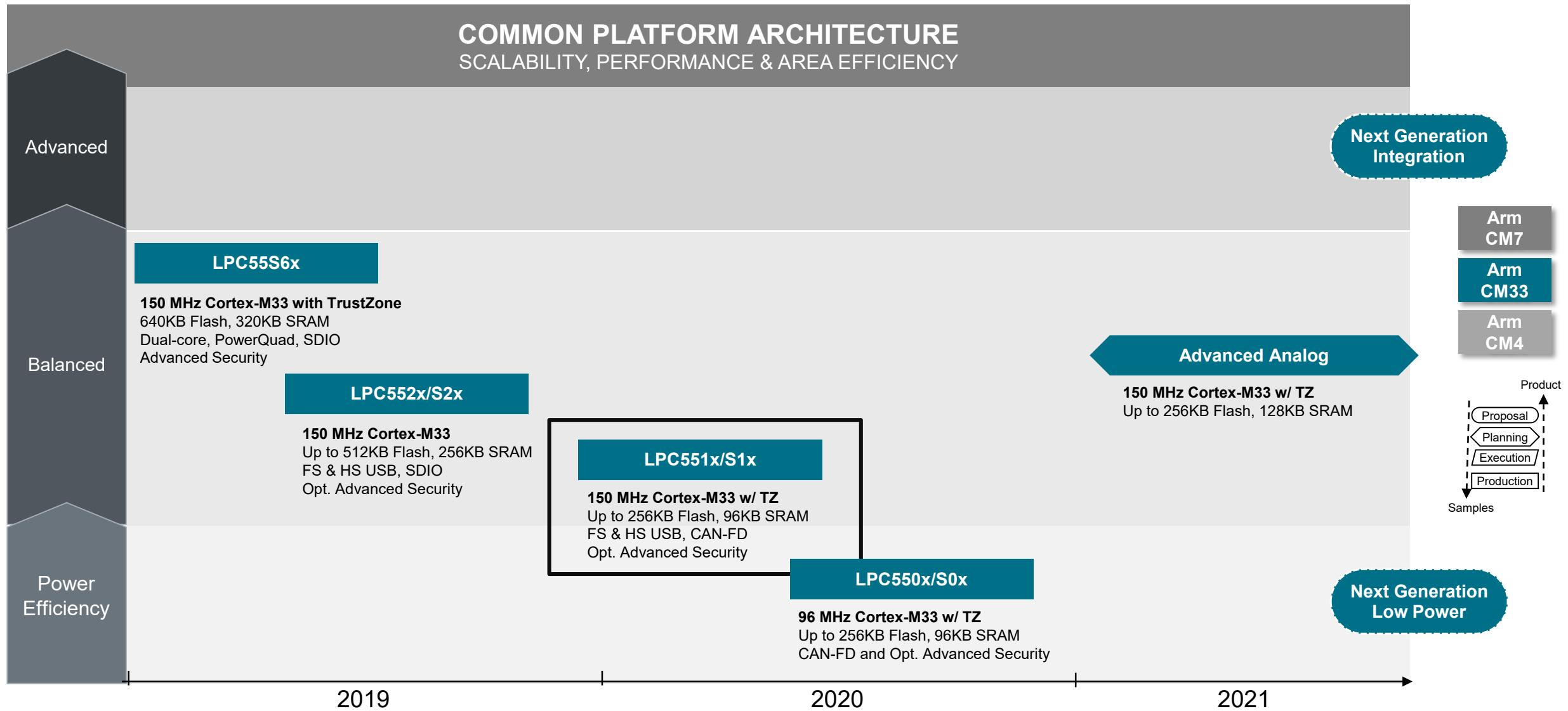



LPC551x/S1x MCU Series

Arm® Cortex®-M33 MCU Series from \$0.97 (USD) at 10Ku

- Ultra-efficient 40-nm flash technology:
 - Over 600 CoreMarks¹ and as low as 32uA/MHz²
- System Integration for Industrial and IoT Markets
 - High-Precision ADCs
 - CAN-FD for industrial control
 - HS USB with On-Chip PHY
- Enhanced safety and security with Arm TrustZone-M technology
- Comprehensive enablement with MCUXpresso Ecosystem

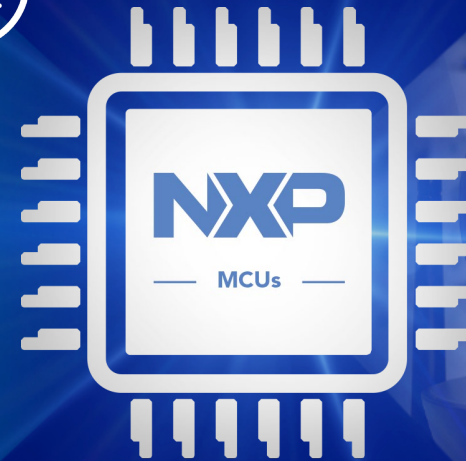

[NXP.COM/LPC5500](https://www.nxp.com/LPC5500)

ADDRESSING COMMON INDUSTRIAL & IOT EMBEDDED SYSTEM CHALLENGES

- **Time to Market**
- **Balancing Power, Performance Efficiency & System Cost**
- **System Vulnerability Protection**
 - Counterfeit Protection
 - Onboarding
 - System Integrity
 - Secure Communication
 - Data Confidentiality
 - Remote Firmware Update



LPC551X MCU FAMILY FEATURES & ENABLEMENT

Hardware Platform for Ease of Development

- **LPC5500 MCU Series EVKs**
 - LPC55S16JBD100 Cortex-M33 microcontroller running at up to 150 MHz
 - High and full speed USB ports with micro A/B connector for host or device functionality.
 - High- and full-speed USB ports
 - NXP TJA1044GTJ High-Speed CAN Transceiver
 - NXP Accelerometer
 - MikroElektronika click expansion option
- On-board debug circuit
- PCB layout, schematic and board files available

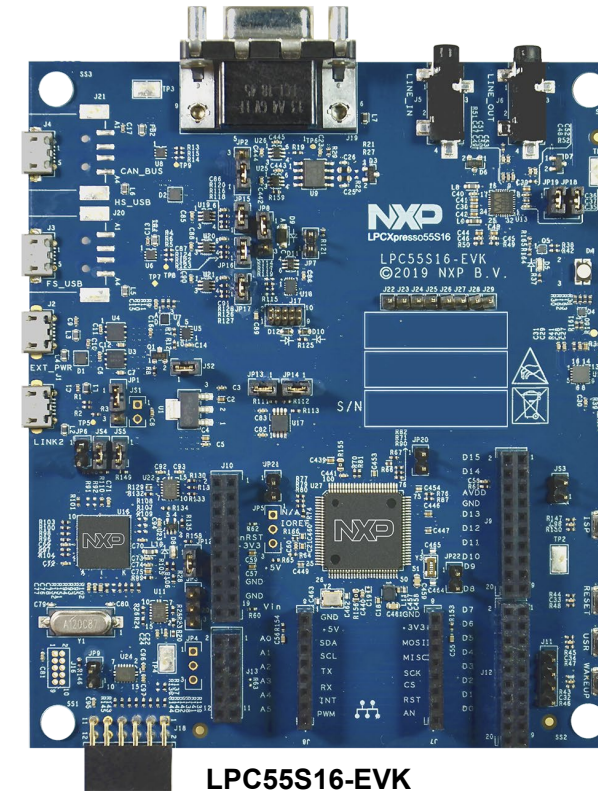

ARM KEIL
Microcontroller Tools

IAR
SYSTEMS



Complimentary with Extensive Support



MCUXpresso SDK



MCUXpresso IDE



MCUXpresso Config Tools

Development Board

S/R Price
(USD)

LPC55S16-EVK: LPCXpresso55S16
Development Board

\$41

LPC551X MCU FAMILY BLOCK DIAGRAM

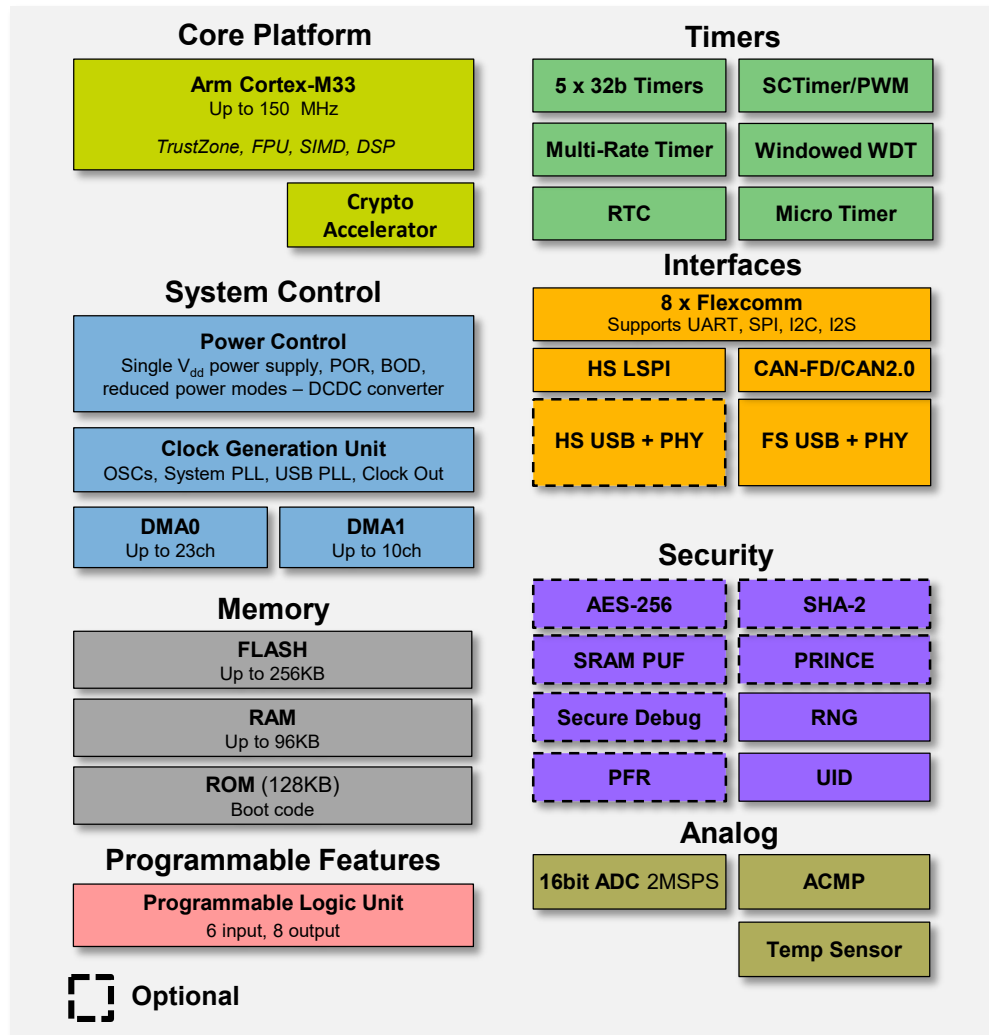

Target Applications



Industrial & Building Automation

- Remote IO and Sensor Nodes
- Elevators and Lifts
- Smart Lighting and Utilities



Consumer Products

- Gaming and PC Peripherals
- Vehicle/Asset Tracking Systems
- Cordless Power Tools and Appliances



Smart Home

- Secure/Biometric Access Control
- Security Systems
- Sensor Nodes

LPC5500 MCU SERIES

COMMON PLATFORM ARCHITECTURE FOR COMPLETE SCALABILITY

	LPC551x/S1x	LPC552x/S2x	LPC55S6x
Cortex-M33 Max Frequency	Up to 150MHz	Up to 150MHz	Up to 150MHz
Cortex-M33 Co-processor	-	-	Yes (Up to 150MHz)
Accelerators/ Co-processors	Crypto Accelerator	Crypto Accelerator	PowerQuad DSP, Crypto Accelerator
Flash	Up to 256 KB	Up to 512KB	Up to 640KB
SRAM	Up to 96KB	Up to 256KB	Up to 320 KB
Security	TrustZone, HW SRAM PUF, Debug Authentication, real-time encryption/ decryption, TRNG, Secure boot, SHA-2, AES-256, PFR	HW SRAM PUF, Debug Authentication, real-time encryption/ decryption, TRNG, Secure boot, SHA-2, AES-256, PFR	TrustZone, HW SRAM PUF, Debug Authentication, real-time encryption/ decryption, TRNG, Secure boot, SHA-2, AES-256, PFR
CoreMarks	600	600	1150+ (Dual-core)
Serial Interfaces	Up to 9 FlexComm supporting USART, SPI, I2C and I2S. 1x HS LSPI	Up to 9 FlexComm supporting USART, SPI, I2C and I2S. 1x HS LSPI	Up to 9 FlexComm supporting USART, SPI, I2C and I2S. 1x HS LSPI
USB	USB FS w/PHY, USB HS w/PHY	USB FS w/PHY, USB HS w/PHY	USB FS w/PHY, USB HS w/PHY
SDIO	-	SDIO/SD/MMC	SDIO/SD/MMC
CAN	CAN FD/CAN 2.0	-	-
ADC	16b 2 Msps	16b 1 Msps	16b 1 Msps
GPIO	Up to 64	Up to 64	Up to 64
Active Power Consumption	32uA/MHz	32uA/MHz	32uA/MHz
Packages	HTQFP64, HLQFP100, VFBGA98	HTQFP64, HLQFP100, VFBGA98	HTQFP64, HLQFP100, VFBGA98

HIGH PERFORMANCE MCU WITHOUT COMPRISING POWER

Power Mode	Current VBAT@3V	Wake Time	Description
Active mode 96 MHz	3.2mA - 34uA/MHz 3.4mA – 36uA/MHz	-	CoreMark from flash (7 WS) CoreMark from SRAM (0 WS)
Active mode 150 MHz	4.9mA - 33uA/MHz 5.8mA – 39uA/MHz	-	CoreMark from flash (11 WS) CoreMark from SRAM (0 WS)
Deepsleep (All 320kB SRAM retained)	70uA	77us	
Powerdown with Retention (with 8kB SRAM retained)	2.4uA	385us	DCDC off, RAM/Padring on, CPU0 and some periph. retained
Deep Powerdown (with 4kB retained)	475nA	4.6ms	DCDC off, RAM, Wakeup pin 4x, reset pad, and PD_AO (PMC, OS timer, PMU) are powered

Deep Powerdown

RTC,
OS-Event Timer,
4x Wakeup Pads,
Pad Reset

Powerdown

Flexcomm3
Comparator
All GPIOs from Port0
& Port1 (via Group
GPIO Interrupt)

DeepSleep

Flexcomm0-7
HS-SPI
CTimer0-4
WDT,
Micro-tick,
USB-FS/HS,
PLU
All GPIOs
BODs

Wakeup Sources

LPC551X INTEGRATES HIGH-SPEED USB WITH INTEGRATED PHYSICAL TRANSCEIVER

BOM benefits

- Integrated 480MHz PLL
- Dedicated USB RAM
- No need for external PHY

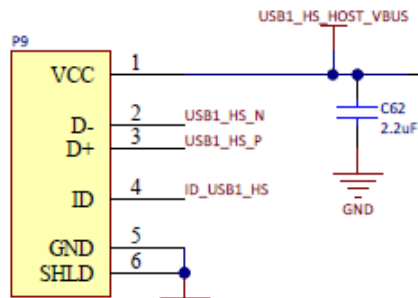

SDK Examples

- Device *audio, cdc, hid, msc, phdc, printer, video*
- Host *audio, cdc, hid, msd, phdc, printer*

Increased throughput

USB FS 12Mbps

USB HS 480 Mbps



Higher data payload (max endpoint size)

Transfers	HS (bytes)	FS (bytes)
Isochronous	1024	1023
Interrupt	1024	64
Bulk	512	64

LPC551X INTEGRATES CAN-FD CONTROLLER

CAN v 2.0 A/B CAN-FD v 1.0

CAN with Flexible Data-Rate offers major benefits over Classical CAN:

Increased data length

- CAN FD supports up to 64 data bytes per data frame, compared to 8 data bytes for Classical CAN
- Leads to a reduction in protocol overhead, and improved protocol efficiency

Increased speed

- CAN FD supports dual bit rates:
 - Nominal bit-rate limited to 1Mbit/s as given in Classical CAN
 - Data bit-rate, which is dependent on network topology and transceivers
- Data bits rates up to 5Mbit/s are achievable in practice

Improved reliability

- CAN FD uses an improved cyclic redundancy check and the “protected stuff-bit counter” to lower the risk of unprotected errors

LPC551X CAN-FD SOFTWARE ENABLEMENT

- NXP provides CAN and CAN FD drivers through the MCUXpresso SDK for enabled designs
- Long-time NXP partner EmSA provides middleware for CAN-based higher-layer protocol
 - CANopen and CANopen FD
 - J1939
 - CANcrypt and CANcrypt FD
- CAN related development tools are also available from EmSA
 - CANopen Magic
 - Flash Magic

www.em-sa.com/nxp

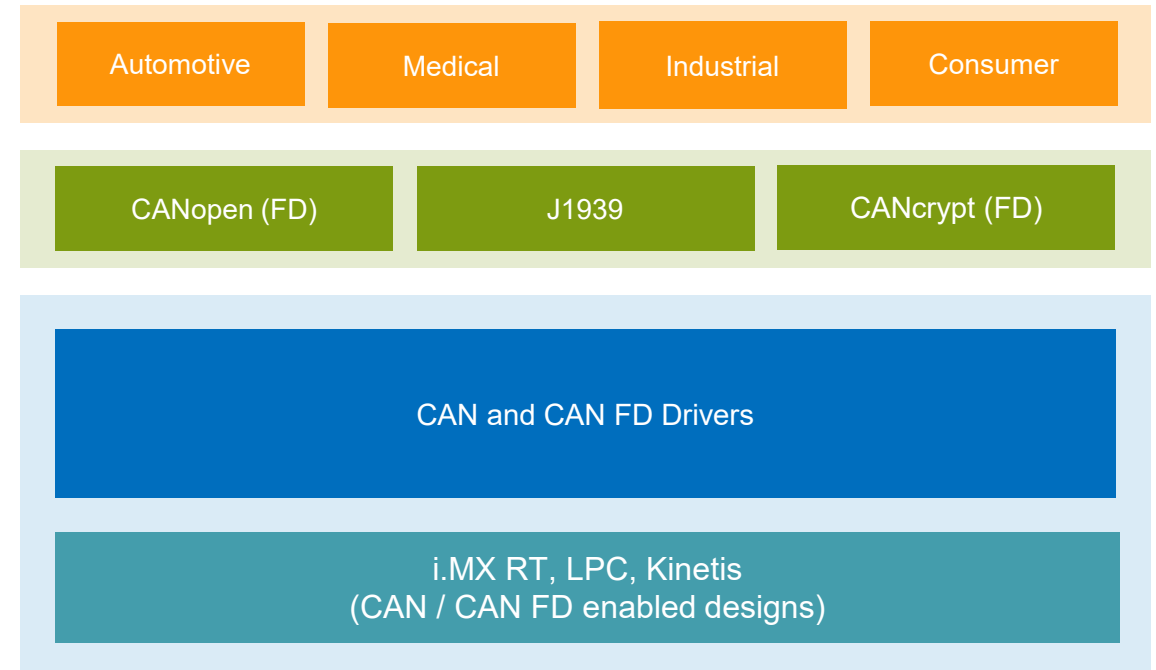

- Middleware distributed by EmSA
- Software distributed by NXP

ENHANCED SECURITY WITH LPC55S1X MCUs



Cryptography Accelerators

HashCrypt symmetric AES and SHA, **PRINCE** on-the-fly FLASH encryption/decryption, **CASPER** asymmetric cryptography, Random Number Generator (**RNG**)



Secure Storage

Secure keys and data using SRAM Physical Unclonable Function (**SRAM PUF**), Protected Flash Region (**PFR**)



Secure Boot

ROM based boot that executes only authorized software



Trusted Execution

Isolated Secure & Non-Secure worlds with **ARM TrustZone** plus NXP implementation **IDAU**, **Secure Bus Control**, **Secure DMA**, **Secure GPIO**



Secure Debug

Debug Authentication to authenticate the debugger and grant it access to the device

LPC551X ADDRESSES SECURITY STANDARDS & CERTIFICATIONS

NXP has partnered with industry leading hardware and software partners to offer 3rd party compliance to industry standards, making certified security solutions more accessible, streamlining development and accelerating time to market.

Addressing Accessibility with Additional Enablement

- **MCU Secure Boot ROM & SW Tools** (elftosb, blhost)
- **Accelerated MbedTLS library**
- **Mbed Crypto**
 - reference implementation of the ARM PSA Crypto API (Q2)
- **Trusted Firmware-M (TF-M)**
 - reference implementation of secure software for ARMv8-M (Q2)



PSA Level 2
Planned Early
Q3-2020



SESIP Assurance
Level 2 (SESIP2)
Planned Early
Q3-2020

PACKAGE SCALABILITY WITH LPC551X MCUs

Common features across families

- FS/HS USB with PHY, 50MHz SPI, up to 8/10 Serial Interfaces (FlexComm), plus I3C interface (LPC557x/8x families)
- Up to 2Msps 16-bit SAR ADC, Comparator, Temperature Sensor and RTC
- 1.8 to 3.6V, -40 to 105 °C

LPC5500 Family	Memory	QFN 48	QFP 64	QFP 100	QFP 144	BGA 98
Efficiency LPC55S6x	Up to 640KB Flash, 320KB SRAM		X	X	(X)	X
Mainstream LPC552x/S2x	Up to 512KB Flash, 256KB SRAM		X	X		X
Entry LPC551x/S1x	256KB Flash, 96KB SRAM	(X)	X	X		X

Pin Compatibility

(X) Package development under scoping

LQFP



HLQFP100
14x14mm-x,y, 1.4mm- z
0.5mm pitch



HTQFP64
10x10mm-x,y, 1.0mm- z
0.5mm pitch

BGA

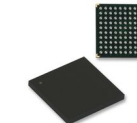

VF BGA98
7x7mm-x,y, 0.86mm- z
0.5mm pitch

QFN



QFN48
7x7mm-x,y, 1.0mm- z
0.5mm pitch

LPC551X OFFERS SMALL PACKAGES WITH EASY PCB ROUTING

VFBGA98 7X7MM (0.5MM PITCH) SUPPORTS 2-LAYER PCB LAYOUT

Special Pop-up Ball Pattern

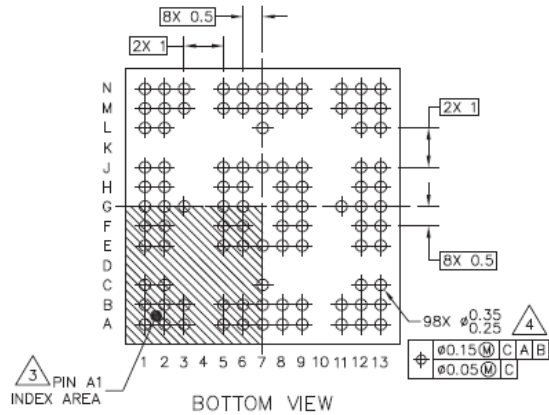

Top Layer Routing View

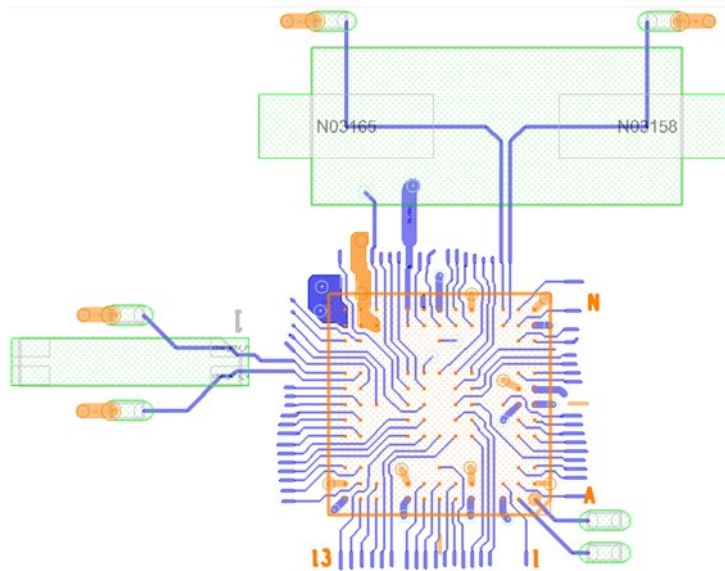

Bottom Layer Routing View

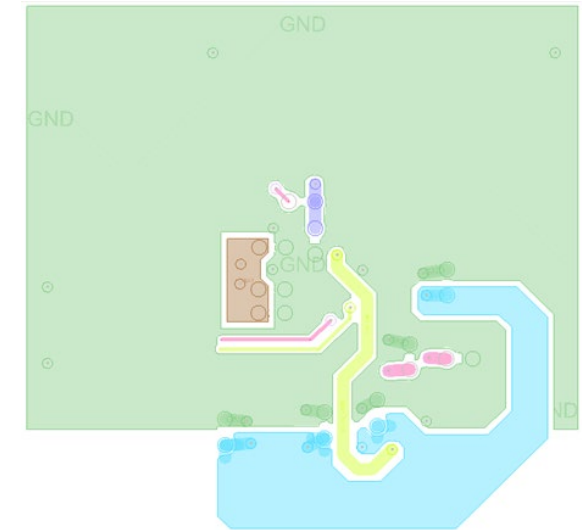

Cost Saving Estimate:

LPC5500 VFBGA98 (Compares with 4-layer-3.2mil)	2-layer-3.2mil width	2-layer-5mil width
PCB NRE fees	45% cheaper	57%-87% cheaper
PCB unit cost	45% cheaper per pc	57%-87% cheaper per pc

Need More Information?

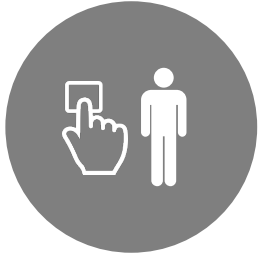

Technical Support

<https://community.nxp.com/welcome>

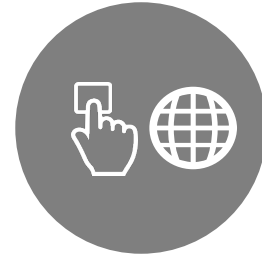

Visit NXP MCUs Online

www.NXP.com/MCU

LEARN MORE

- NXP LPC55S16-EVK: Unboxing and First Impressions | [Read On >](#)
- LPC55S16-EVK: How fast does it go? How much current does it take? | [Read On >](#)
- Extend MCU Security Capabilities Beyond Trusted Execution with Hardware Crypto Acceleration and Protection | [Read One >](#)

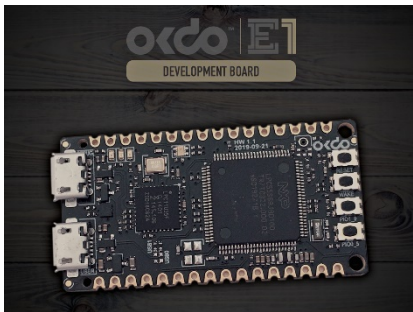

E1 – The New LPC55S69 MCU-Based Board from OKdo

Release this week, this small form factor LPC55S6x-based board offers a high-performance, secure low-cost entry to the IoT, enabling users, from makers to industrialists, to develop connected solutions that are robust and secure.

UPCOMING WEBINAR

May 27 10 a.m. Central

[REGISTER NOW >>](#)

Additional Resources

Videos

- [MCU Tech Minutes | Exploring the Dual-Core Feature on LPC5500 Series MCUs](#)
- [MCU Tech Minutes | Exploring the SCTimer Feature on LPC5500 Series MCUs](#)
- [MCU Tech Minutes | Exploring the Available Wi-Fi Enablement Options on LPC5500 Series MCUs](#)
- [MCU Tech Minutes | Exploring the Arm® TrustZone® Feature on LPC5500 Series MCUs](#)

Blogs

- [LPC5500 MCU Series: There's a lot under the hood \(Part 1 of 3\)](#)
- [LPC5500 Series: There's a lot under the hood \(Part 2 of 3\) - Dual USB and Lots of RAM](#)
- [LPC5500 MCU Series: There's a lot under the hood \(Part 3 of 3\) - SCT, "Programmable Logic" and Boot ROM](#)
- ["Mini-Monkey" Part 1: How to design with the LPC55S69 in the VFBGA98 package](#)
- ["Mini-Monkey" Part 2: Using MCUXpresso to Accelerate the PCB Design Process](#)
- [LPC55S69 Mini-Monkey Build Update – Off to Fabrication!](#)

On-Demand Training

- [CANopen and NXP Microcontrollers: Proliferating robust network communication with fast evaluation and deployment](#)
- [Secure Provisioning and Programming Using Embedded Trust and the Security-enabled LPC55S6x MCU](#)
- [Enabling Secure, NB-IoT End Nodes with MCUXpresso Enablement and PSA-certified MCUs to Address the Growing Industrial IoT Market](#)
- [Enabling Next-Gen IoT Applications With Secure-enabled NXP MCUs with TrustZone®-M Technology](#)
- [Enabling Motor Control Across a Range of NXP MCUs with MCUXpresso and FreeMASTER Visualization Tools](#)
- [Exploring the Latest Features of MCUXpresso v11.1](#)
- [Accelerate Development of Robust Network Communications with CANopen and CANopen FD](#)





SECURE CONNECTIONS
FOR A SMARTER WORLD