

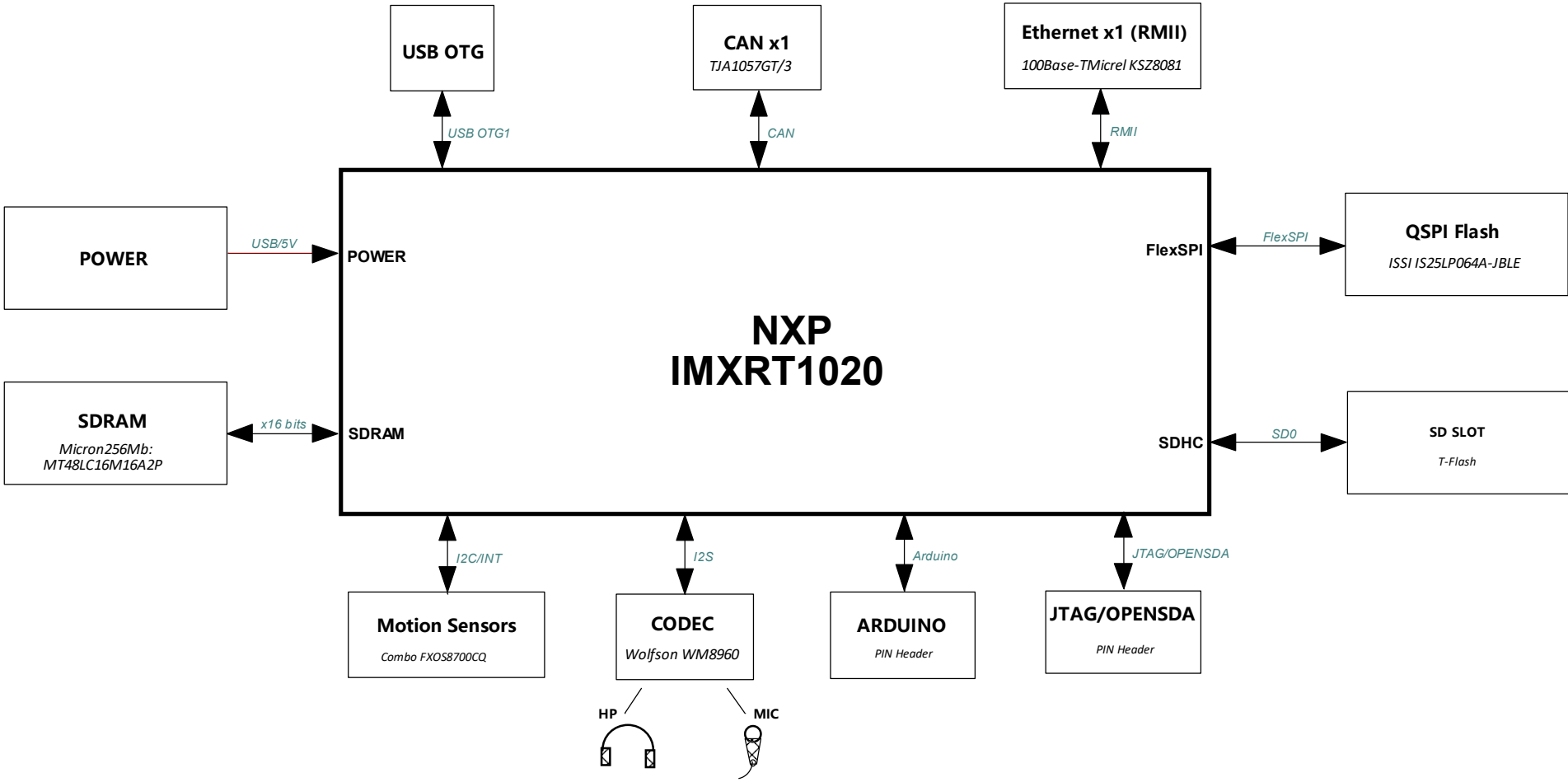

# MIMXRT1020-EVK

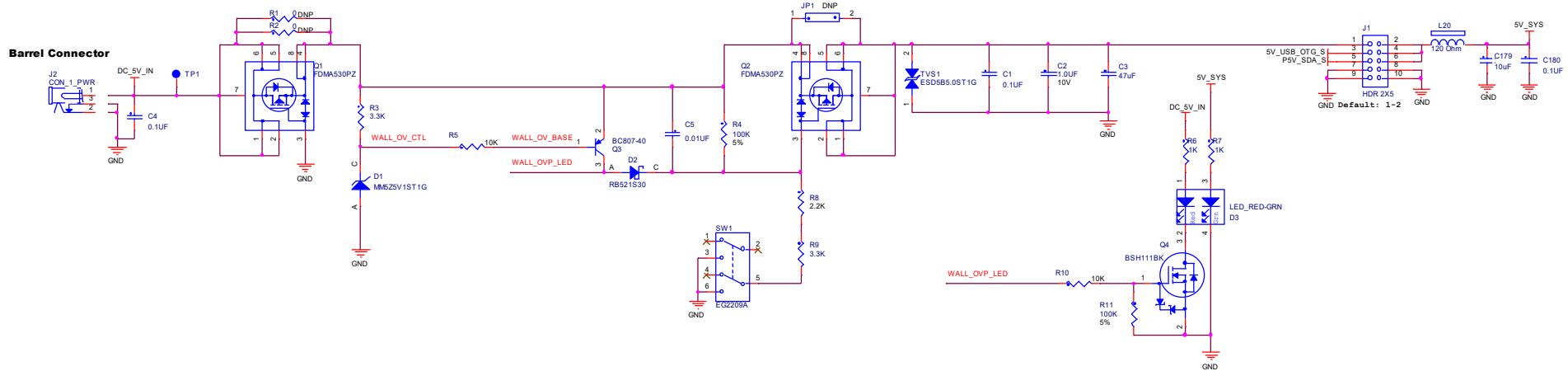

# Main Power



# Board Mounting Holes

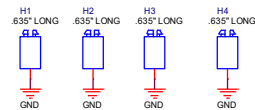

# Ground TPs

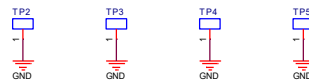

Layout Note: Place Ground TPs to assist signal measurement.

ICAP Classification: CP: ___ IUC: X PUBI: ___			
Drawing Title: <b>MIMXRT1020-EVK</b>			
Page Title: <b>MAN POWER</b>			
Size C	Document Number	SCH-29856, PDF: SPF-29856	Rev B1
Date:	Monday, October 22, 2018	Sheet 3	of 15

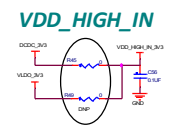
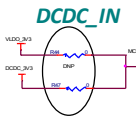
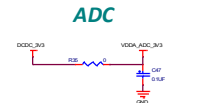
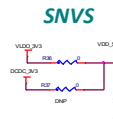
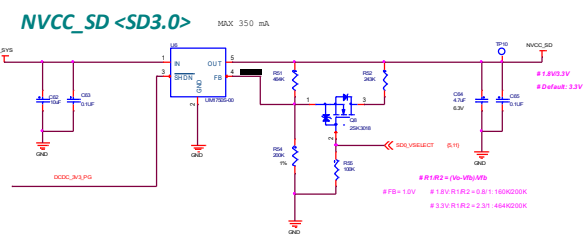
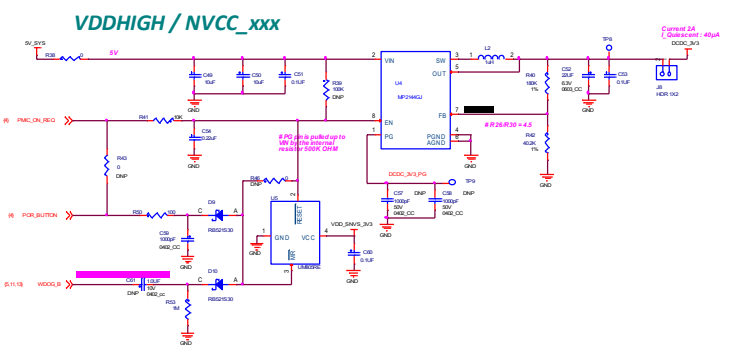
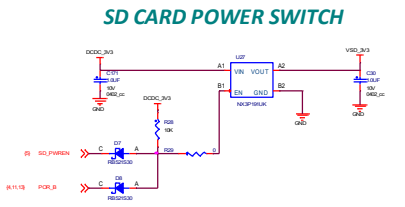
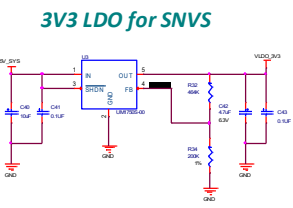
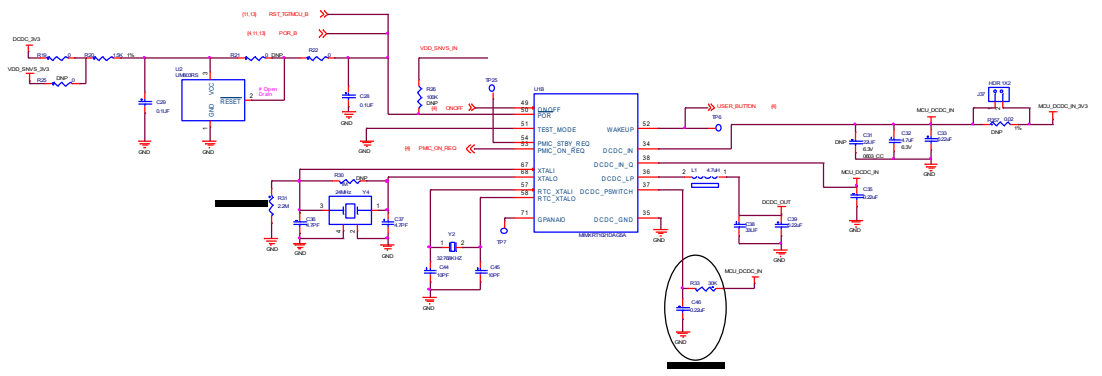
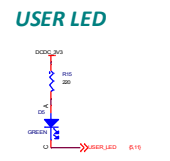
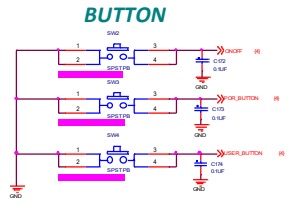
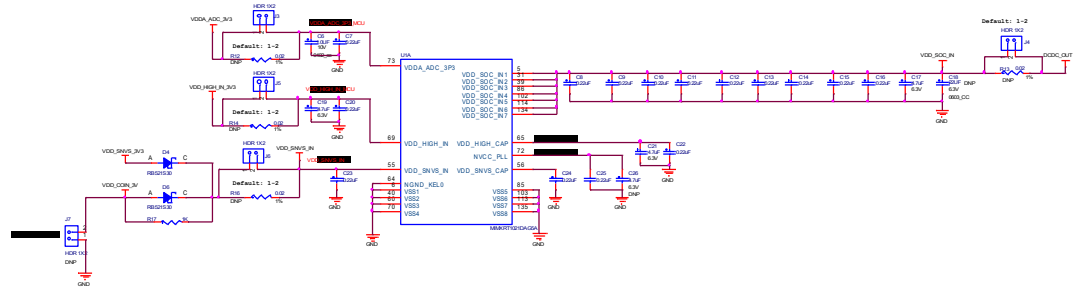



## USB OTG

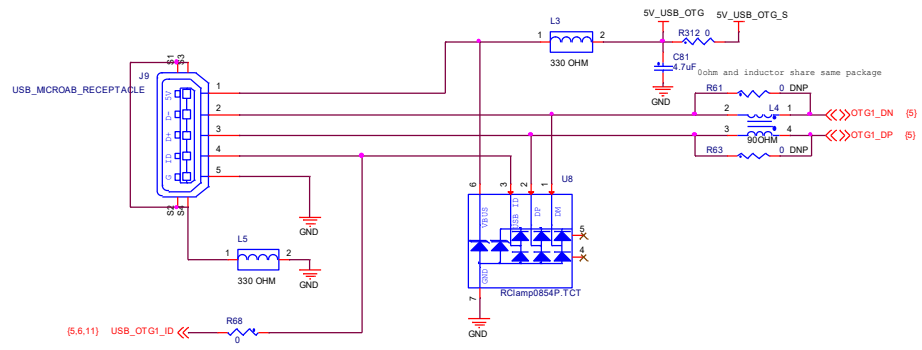

## USB POWER

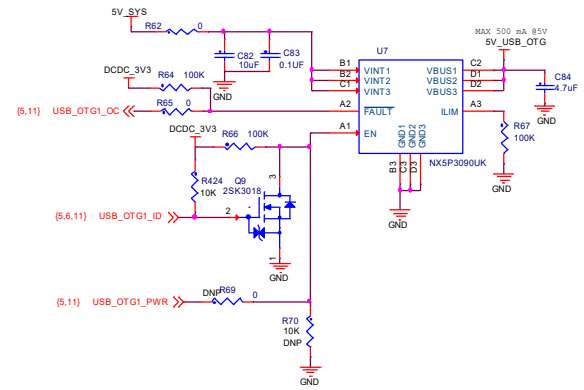

ICAP Classification: CP: ___ IUC: X PUBI: ___			
Drawing Title: <b>MIMXRT1020-EVK</b>			
Page Title: <b>USB</b>			
Size C	Document Number	SCH-29856, PDF: SPF-29856	Rev B1
Date:	Monday, October 22, 2018	Sheet 8 of 15	

# CAN BUS

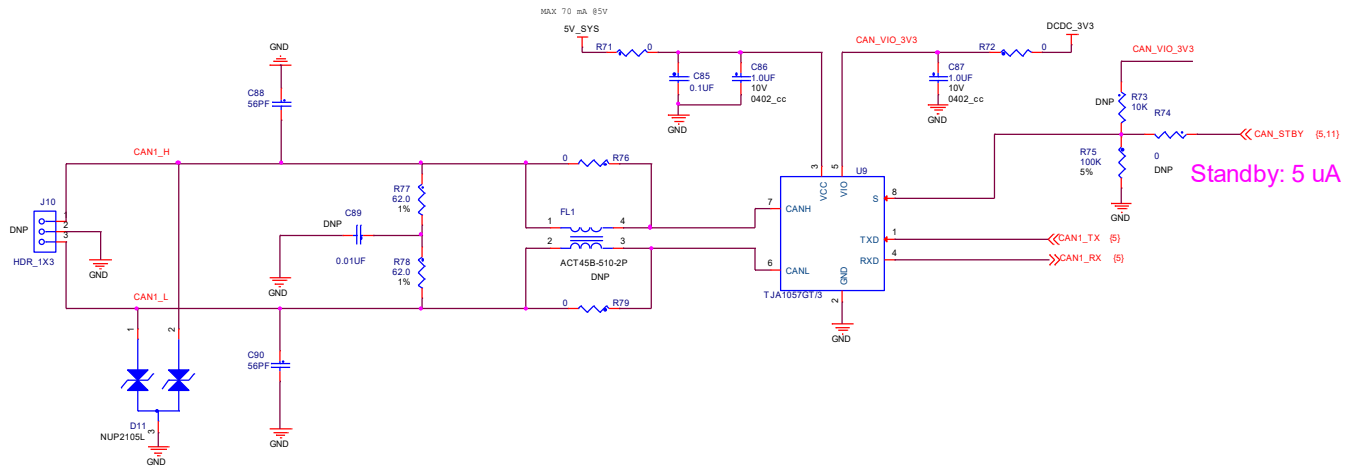

ICAP Classification: CP: ___ IUC: X PUBI: ___			
Drawing Title: <b>MIMXRT1020-EVK</b>			
Page Title: <b>CAN</b>			
Size C	Document Number SCH-29856, PDF: SPF-29856	Rev B1	
Date: Monday, October 22, 2018	Sheet 7	of 15	

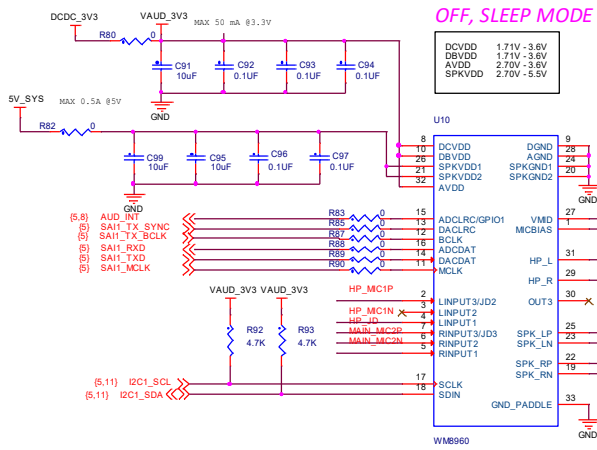

### Main Board MIC

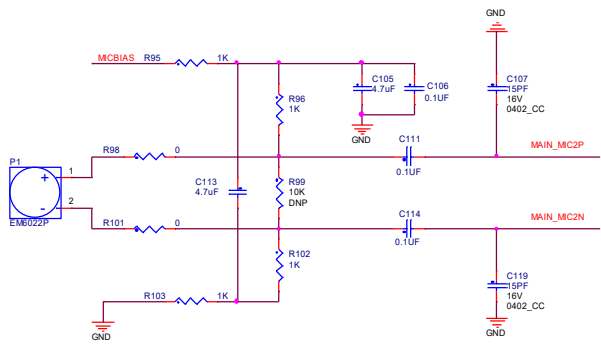

### HP MIC

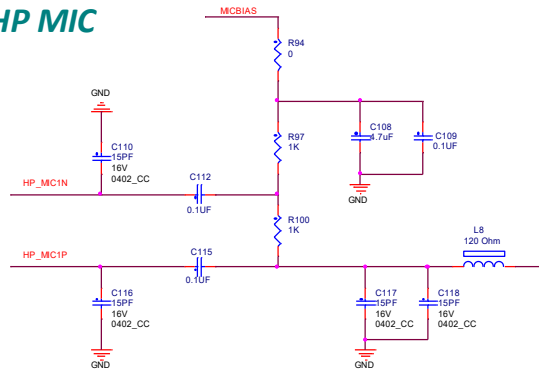

### Speaker

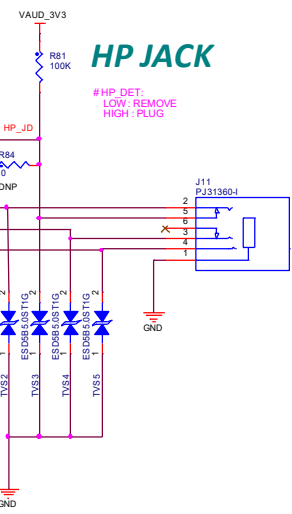
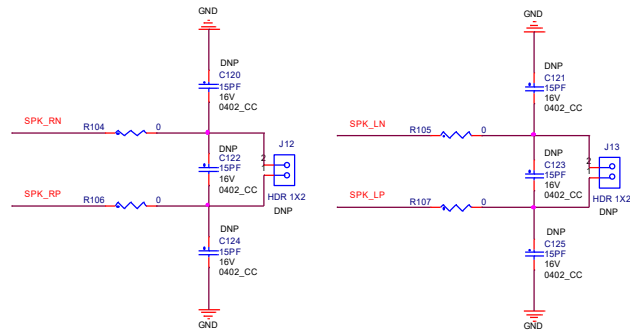

ICAP Classification: CP: \_\_\_ IUC: X PUBI: \_\_\_  
 Drawing Title: **MIMXRT1020-EVK**  
 Page Title: **AUDIO**  
 Size C Document Number SCH-29856, PDF: SPF-29856 Rev B1  
 Date: Monday, October 22, 2018 Sheet 8 of 15



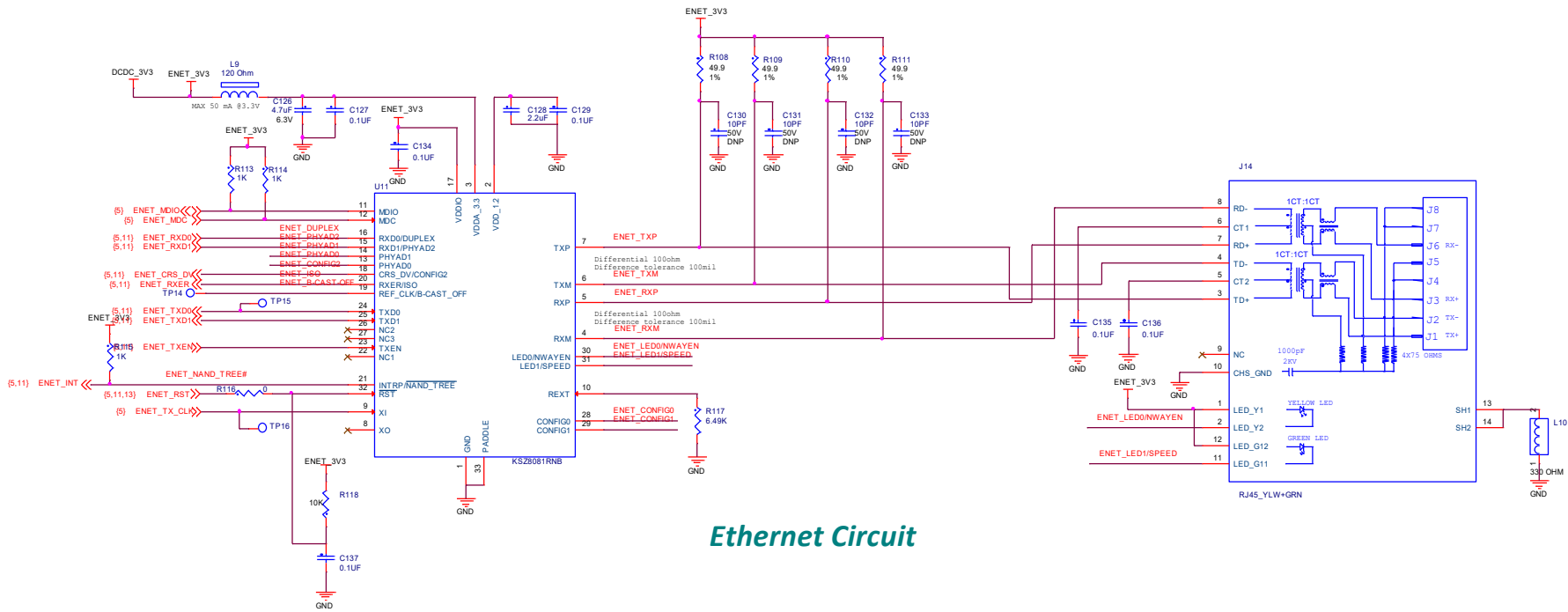

**Ethernet Circuit**

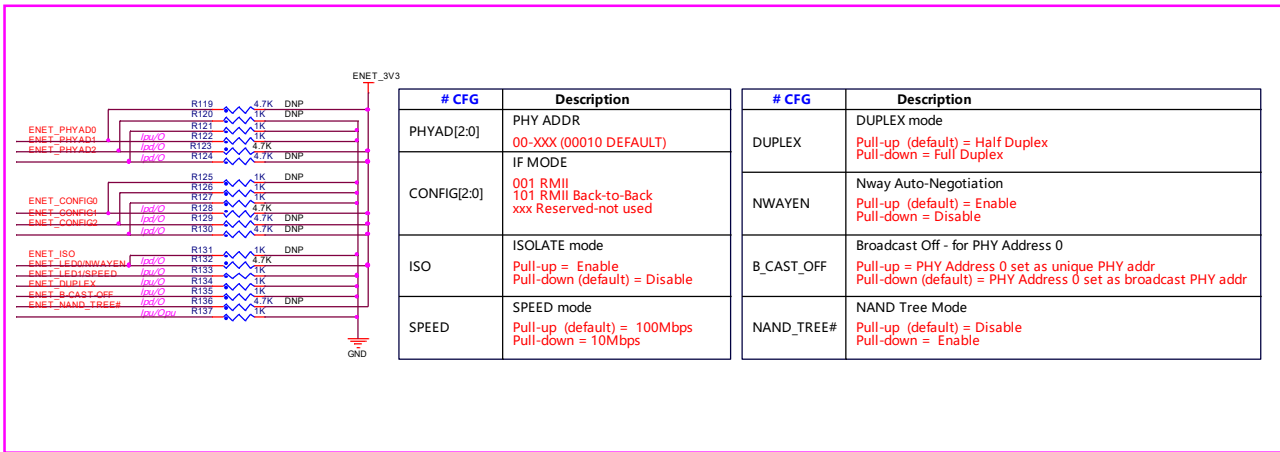

**ESD PROTECTION**

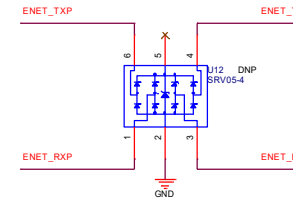

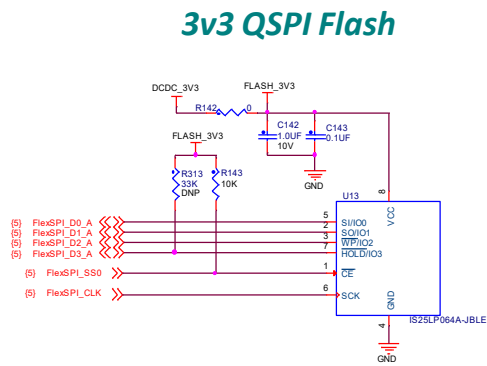
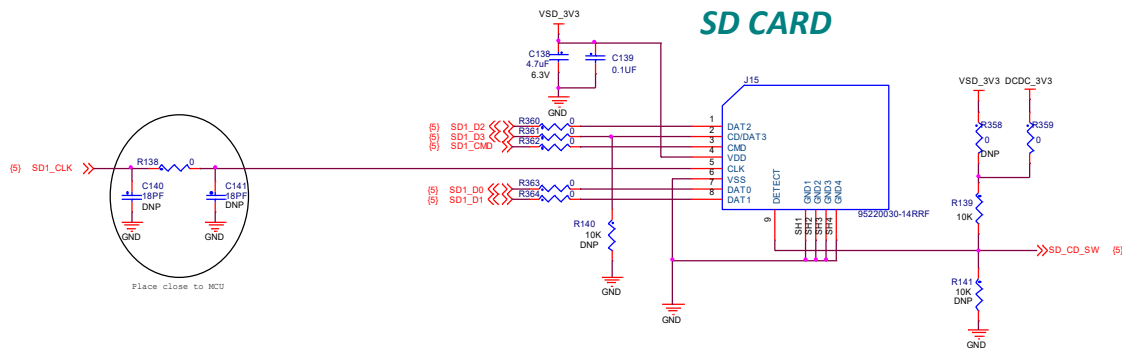

ICAP Classification: CP: ___ IUC: X PUBI: ___			
Drawing Title: <b>MIMXRT1020-EVK</b>			
Page Title: <b>SDFLASH</b>			
Size C	Document Number	SCH-29856, PDF: SPF-29856	Rev B1
Date:	Monday, October 22, 2018	Sheet 10 of 15	

# JTAG

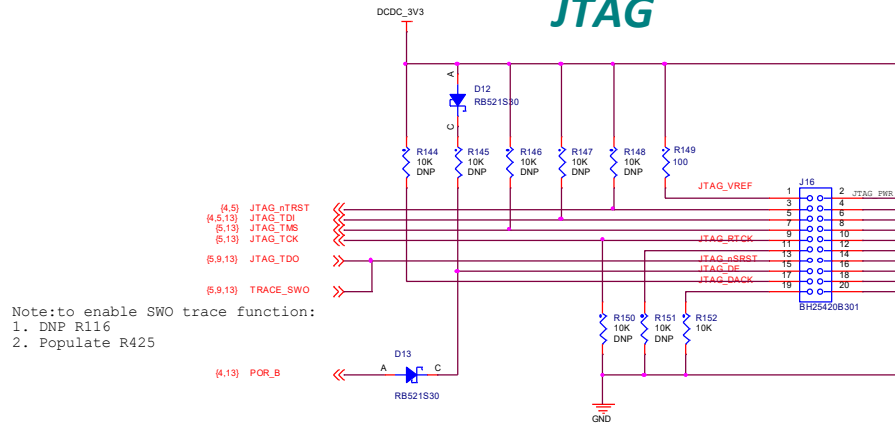

# Arduino Interface

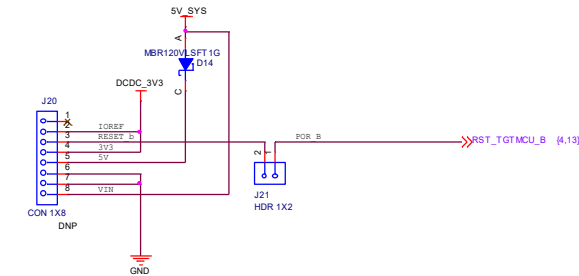
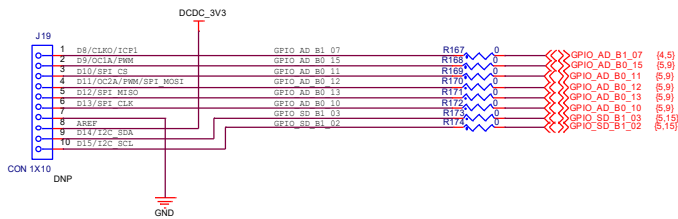
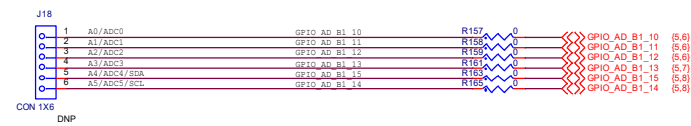
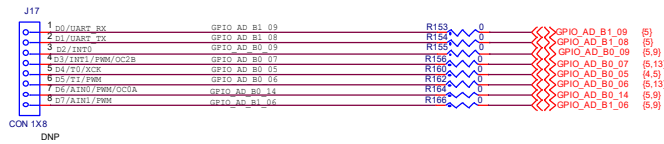

# SDRAM

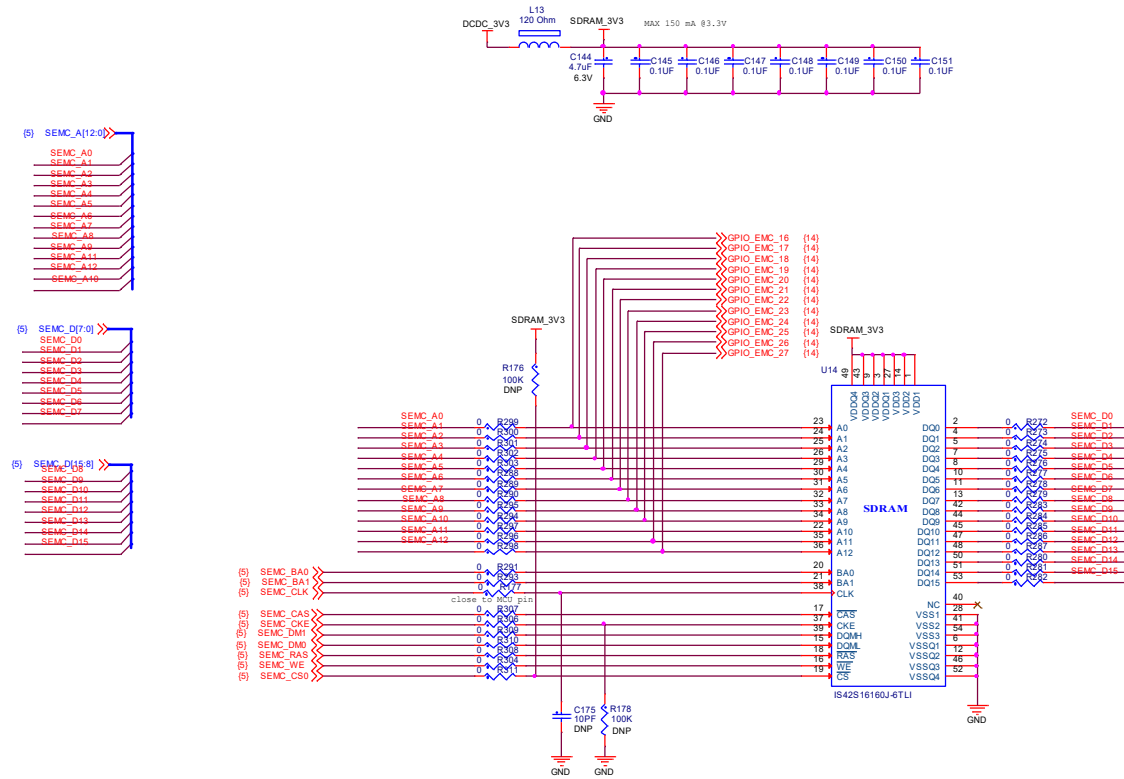

- (5) SEMC\_A[12:0]
  - SEMC\_A0
  - SEMC\_A1
  - SEMC\_A2
  - SEMC\_A3
  - SEMC\_A4
  - SEMC\_A5
  - SEMC\_A6
  - SEMC\_A7
  - SEMC\_A8
  - SEMC\_A9
  - SEMC\_A10
  - SEMC\_A11
  - SEMC\_A12
  - SEMC\_A13
  - SEMC\_A14

- (5) SEMC\_D[7:0]
  - SEMC\_D0
  - SEMC\_D1
  - SEMC\_D2
  - SEMC\_D3
  - SEMC\_D4
  - SEMC\_D5
  - SEMC\_D6
  - SEMC\_D7

- (5) SEMC\_D[15:8]
  - SEMC\_D8
  - SEMC\_D9
  - SEMC\_D10
  - SEMC\_D11
  - SEMC\_D12
  - SEMC\_D13
  - SEMC\_D14
  - SEMC\_D15

- (5) SEMC\_BA0
- (5) SEMC\_BA1
- (5) SEMC\_CLK
- (5) SEMC\_CAS
- (5) SEMC\_CKE
- (5) SEMC\_DM0
- (5) SEMC\_DM1
- (5) SEMC\_DMH
- (5) SEMC\_RAS
- (5) SEMC\_WE
- (5) SEMC\_CS



# FUSE MAP

TYPE	0/1	0/1	0/1	0/1	0/1	0/1	0/1	0/1	0/1	0/1	0/1
	BOOT_CFG[9]	BOOT_CFG[8]	BOOT_CFG[7]	BOOT_CFG[6]	BOOT_CFG[5]	BOOT_CFG[4]	BOOT_CFG[3]	BOOT_CFG[2]	BOOT_CFG[1]	BOOT_CFG[0]	
<b>FlexSPI1 - Serial NOR</b>	HOLD TIME: 00 - 500us 01 - 1ms 10 - 3ms 11 - 10ms		0	0	0	0	FLASH_TYPE: 000-Device supports 3B read by default 001-Device supports 4B read by default 010-HyperFlash 1V8 011-HyperFlash 3V3 100-MXIC Octal DDR 101 - Micron Octal DDR 111 - QSPI device supports 3B read by default (on secondary pinmux option)				EncryptedXIP 0 - Disabled 1 - Enabled
<b>SD</b>	SD/SDXC Speed: 00 - Normal/SDR12 01 - High/SDR25 10 - SDR50 11 - SDR104	0	0	1	Bus Width: 0 - 1-bit 1 - 4-bit	SD Power Cycle Enable: '0' - No power cycle '1' - Enabled via USDHC_RST pad	SD Loopback Clock Source Sel: (for SDR50 and SDR104 only) '0' - through SD pad '1' - direct	Port Select: 0 - eSDHC1 1 - eSDHC2	Fast Boot: 0 - Regular 1 - Fast Boot		
<b>FlexSPI1 - Serial NAND</b>	"CS_INTERVAL: CS de-asserted interval between two commands 0 - 100ns 1 - 200ns 2 - 400ns 3 - 50ns"	1	1	BOOT_SEARCH COUNT: 0 - 1 1 - 2	COL_ADDRESS WIDTH: 0 - 12bits 1 - 13bits	SPI NAND HOLD TIME 00 - 0 us 01 - 500us 10 - 1ms 11 - 3ms	BOOT_SEARCH_STRIDE: Search Stride for FCB and DBBT (in terms of pages) 0 - 64 1 - 128 2 - 256 3 - 32				

