



ELECTRONICS

Preliminary

DATE : 2007. 02. 10

SAMSUNG TFT-LCD
MODEL NO. : LMS700JF01-001

NOTE :

Any Modification of Spec is not allowed without SEC's permission.

APPROVED BY : _____

PREPARED BY : **Mobile Display R&D Team, AMLCD Division**

SAMSUNG ELECTRONICS CO., LTD.



CONTENTS

Revision History	----- (3)
General Description	----- (4)
1. Absolute Maximum Ratings	----- (5)
1.1 Absolute Ratings Of Environment	
1.2 Electrical Absolute Ratings	
2. Optical Characteristics	----- (7)
3. Electrical Characteristics	----- (10)
3.1 TFT LCD Module	
3.2 Back-light Unit	
4. Touch Screen Panel Specification	----- (13)
4.1 Electrical Characteristics	
4.2 Mechanical & Reliability Characteristics	
4.3 Design Guide	
	----- (15)
5. Block Diagram	
5.1 TFT LCD Module	
5.2 Back-light Unit	
5.3 Touch Panel Unit	
6. Input Terminal Pin Assignment	----- (17)
6.1 Input Signal & Power	
6.2 LVDS Interface	
6.3 Back-light Unit	
6.4 Timing Diagrams of LVDS For Transmitting	
6.5 Input Signals, Basic Display Colors and Gray Scale of Each Color.	
6.6 Pixel format	
7. Interface Timing	----- (22)
7.1 Timing Parameters	
7.2 Power ON/OFF Sequence	
8. Outline Dimension	----- (24)
9. Packing	----- (26)
10. Markings & others	----- (27)
11. General Precautions	----- (29)

Revision History

Preliminary

Date	Rev.No.	Page	Summary
Sept.21.2006	000		Rev.000 was first issues.
Nov.23.2006	001		Rev.001 was modified mechanical outline
Feb.10.2007	002		Rev.002 is issued.
		Page.7	Optical Characteristics is revised. (color chromaticity)
		Page.10	Electrical Characteristics is revised.
		Page.13	TSP Specifications is revised.

GENERAL DESCRIPTION

DESCRIPTION

LTP700WS-F01 is a color active matrix TFT (Thin Film Transistor) liquid crystal display (LCD) that uses amorphous silicon TFT as a switching devices. This model is composed of a TFT LCD panel, a driver circuit and a back-light system. The resolution of a 7.0" contains 1024 x 600pixels and can display up to 262,144 colors. 6 o'clock direction is the optimum viewing angle.

FEATURES

- High Brightness
- High speed response time
- High contrast ratio
- WSVGA (1024 x 600pixels) resolution
- Low power consumption
- DE(Data enable) mode
- LVDS Interface with 1 pixel / clock (1 channel)

APPLICATIONS

- Display terminals for Digital AV application products
- Amusement application products
- Monitors for Industrial machine
- Please contact SEC when using on not specified applications

GENERAL INFORMATION

ITEM	SPECIFICATION	UNIT	NOTE
Display area	153.6(H) x 90.0(V) (7.0" diagonal)	mm	
Driver element	a-Si TFT active matrix		
Display colors	262,144		
Number of pixel	1024 x 600 (WSVGA)	pixel	
Pixel arrangement	RGB vertical stripe		
Pixel pitch	0.150(H) x 0.150(V) (TYP.)	mm	
Display Mode	Normally white		

MECHANICAL INFORMATION

ITEM		MIN.	TYP.	MAX.	UNIT	NOTE
Module size	Horizontal (H)	162.1	162.4	162.7	mm	
	Vertical (V)	101.7	102.0	102.3	mm	
	Thickness (D)	5.6	5.85	6.1	mm	
Weight		-	125.5		g	

1. ABSOLUTE MAXIMUM RATINGS

1.1 ABSOLUTE RATINGS OF ENVIRONMENT

ITEM	SYMBOL	MIN.	MAX.	UNIT	NOTE
Storage temperature	T _{STG}	-30	70	°C	(1)
Operating temperature (Temperature of glass surface)	T _{OPR}	-20	60	°C	(1)
Shock (non-operating)	Snop	-	100	G	(2),(4)
Vibration (non-operating)	Vnop	-	1.5	G	(3),(4)

Note (1) Temperature and relative humidity range are shown in the figure below.
 95 % RH Max. (50 °C ≥ Ta)
 Maximum wet - bulb temperature at 39 °C or less. (Ta > 50°C) No condensation.

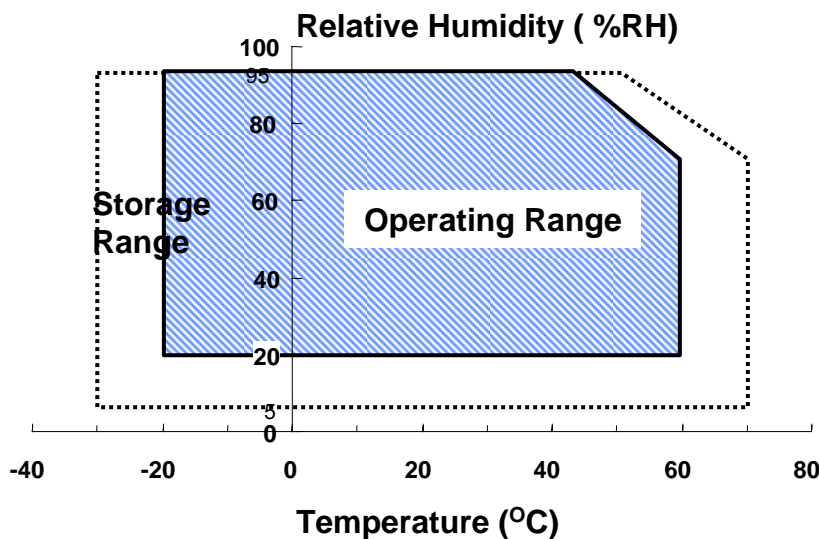

- (2) 6ms, (half) sine wave, one time for ± X, ± Y, ± Z.
- (3) (10) - (500) Hz, Sweep rate (1) hr, (3)hr for X,Y,Z.
- (4) At testing Vibration and Shock, the fixture in holding the Module to be tested have to be hard and rigid enough so that the Module would not be twisted or bent by the fixture.

1.2 ELECTRICAL ABSOLUTE RATINGS

(1) TFT LCD MODULE

(V_{ss} = GND = 0 V)

ITEM	SYMBOL	MIN.	MAX.	UNIT	NOTE
Power Supply Voltage	V _{DD}	V _{ss} -0.3	3.8	V	(1)
Logic Input Voltage	V _{IN}	V _{ss} -0.3	V _{DD} +0.3	V	(1)

NOTE (1) Within Ta = 25 ± 2 °C

(2) BACK-LIGHT UNIT

Ta = 25 ± 2 °C

ITEM	SYMBOL	MIN.	MAX.	UNIT.	NOTE
Led current	I _L	-	30	mA	(1)

NOTE (1) Permanent damage to the device may occur if maximum values are exceeded.
Functional operation should be restricted to the conditions described under Normal Operating Conditions.

2. OPTICAL CHARACTERISTICS

The following items are measured under stable conditions. The optical characteristics should be measured in a dark room or equivalent state with the methods shown in Note (1). Measuring equipment: SR-3, BM-7, EZ-Contrast

* Ta = 25 ± 2°C, VCC = 3.3V, fv = 60Hz, IL = 20mA

ITEM		SYMBOL	CONDITION	MIN.	TYP.	MAX.	UNIT	NOTE	
Contrast Ratio (1 Points)		CR	$\phi = 0,$ $\theta = 0$ Normal Viewing Angle		350	-		(1), (2), (5)	
Response Time	Rising TR	TR + TF			-	30		msec	(1), (3)
	Falling TF								
Luminance of White (center)		YL				280	-	cd/m ²	(1), (4)
Color Chromaticity (CIE 1931)	Red	Rx				0.600			(1), (5) -
		Ry				0.366			
	Green	Gx				0.350			
		Gy				0.554			
	Blue	Bx				0.150			
		By				0.117			
	White	Wx			0.322				
		Wy			0.340				
Viewing Angle	Hor.	θ_L	CR ≥ 10		TBD	-	Degrees	(1)	
		θ_R			TBD	-			
	Ver.	ϕ_H			TBD	-			
		ϕ_L			TBD	-			
5 Points White Variation		δ_L		-	1.13			(6)	

* Viewing Angle : Ez-contrast

Note 1) Definition of Viewing Angle : Viewing angle range($10 \leq C/R$)

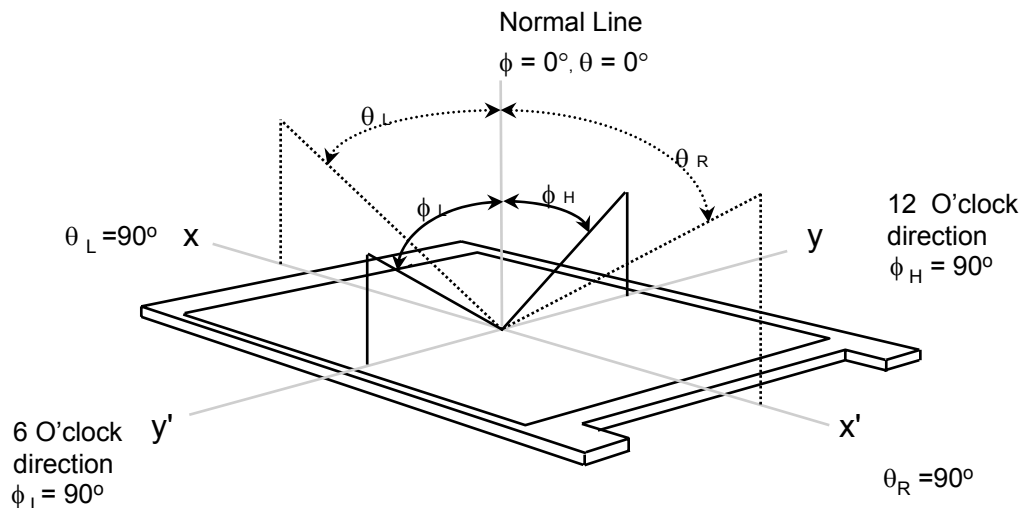

Note 2) Definition of Contrast Ratio (CR) : Ratio of gray max (Gmax) ,gray min (Gmin) at center point

$$CR = \frac{\text{gray max (Gmax)}}{\text{gray min (Gmin)}}$$

Note 3) Definition of Response time :

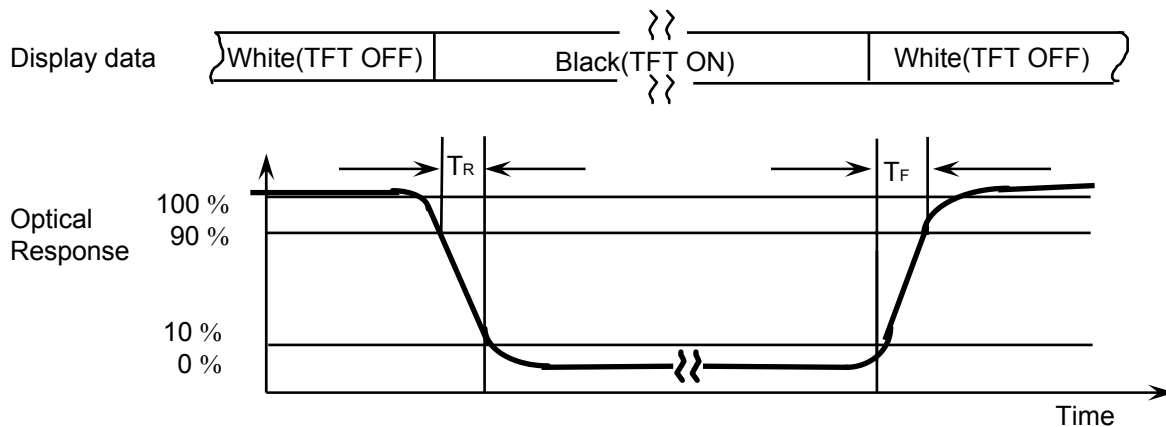

Note 4) Definition of Luminance of White : measure the luminance of white at center point(@ ③)

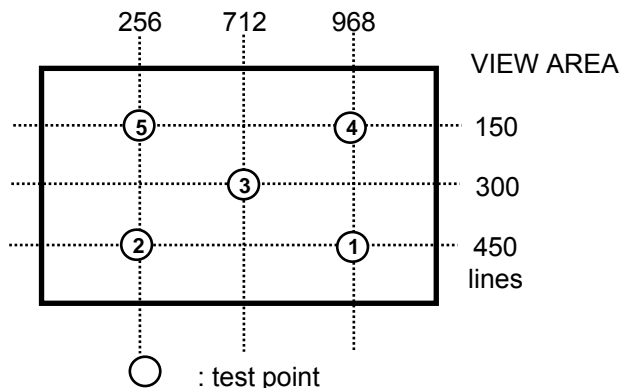

Note 5) After stabilizing and leaving the panel alone at a given temperature for 30 minutes, the measurement should be executed. Measurement should be executed in a stable, windless, and dark room. 30 minutes after lighting the back-light. This should be measured in the center of screen.
 Lamp current : 6.0 mA
 Environment condition : $T_a = 25 \pm 2 \text{ }^\circ\text{C}$

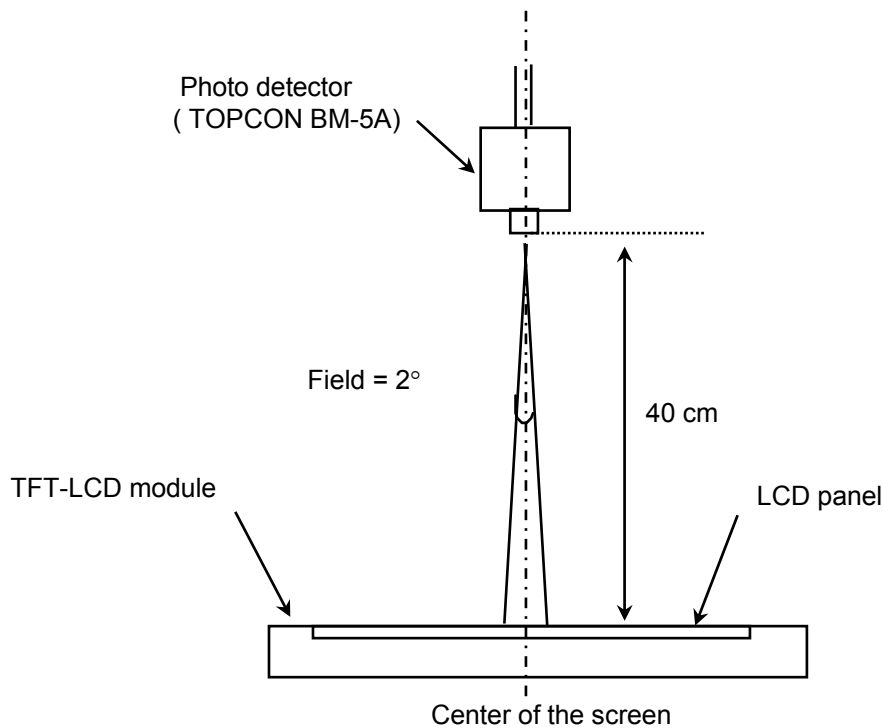

Optical characteristics measurement setup

Note 6) Definition of 5 points white variation (δ_L) [① ~ ⑤]

$$\delta_L = \frac{\text{Maximum luminance of 5 points}}{\text{Minimum luminance of 5 points}}$$

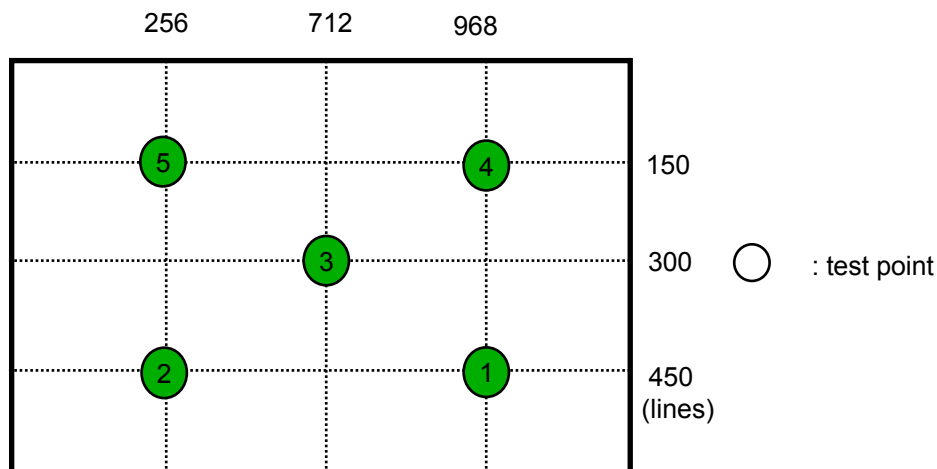

3. ELECTRICAL CHARACTERISTICS

3.1 TFT LCD MODULE

Ta = 25 ± 2°C

ITEM		SYMBOL	MIN	TYP	MAX	UNIT	NOTE
Voltage of Power Supply		V _{DD}	3.0	3.3	3.6	V	
Differential Input Voltage for LVDS Receiver Threshold	High	V _{IH}	-	-	+100	mV	(1)
	Low	V _{IL}	-100	-	-	mV	
Vsync Frequency		f _v	-	60	-	Hz	
Hsync Frequency		f _H	-	37.94	-	KHz	
Main Frequency		f _{DCLK}	-	51.0	-	MHz	
Rush Current		I _{RUSH}	-	-	1.5	A	(5)
Current of Power Supply	White	I _{DD}	-	218		mA	(2),(4)
	Mosaic		-	264		mA	(2),(4)
	Black		-	286		mA	(2),(4)

Note (1) Condition : V_{CM}=+1.2V(Common mode Voltage)

(2) f_v=60Hz, f_{DCLK} = 51.0MHZ, V_{DD} = 3.3V , DC Current.

(3) 1 pixel /clock

(4) Power dissipation check pattern

*a) White Pattern

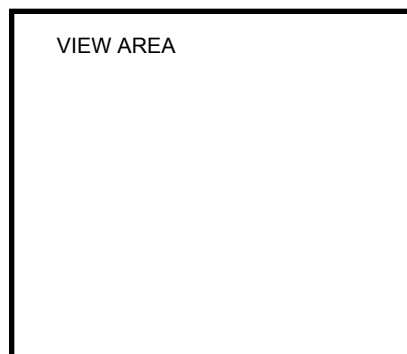

*b)Mosaic Pattern

Display Brightest Gray Level →

Display Darkest Gray Level →

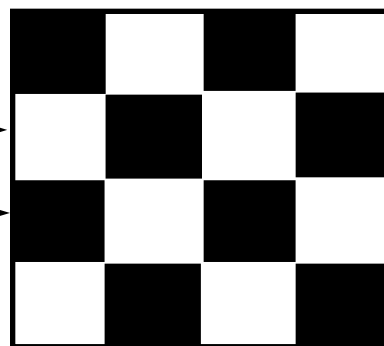

*c) Black pattern



5) Rush current measurement condition

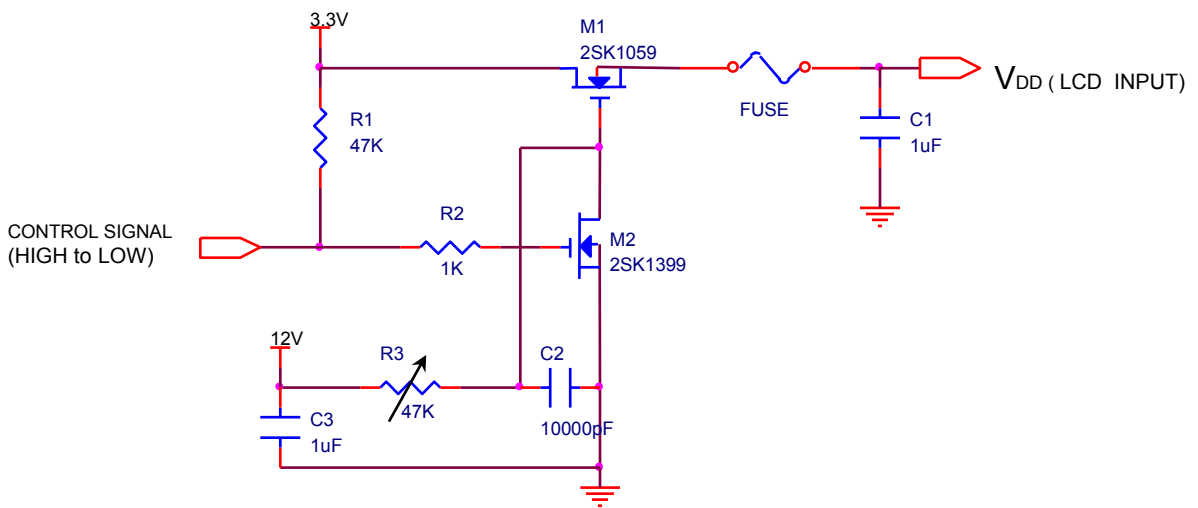

V_{DD} rising time is 470us

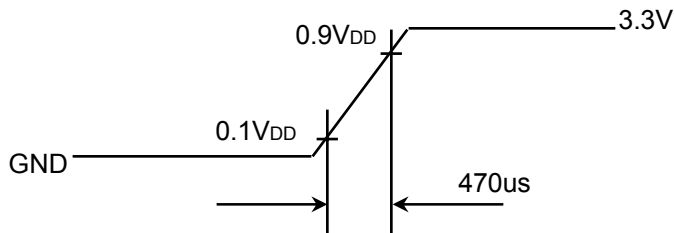

3.2 BACKLIGHT UNIT

The Back Light system is an edge-lighting type with 21 white LED (Light Emitting Diodes)

INVERTER : SCF-0277

Ta=25 ± 2°C

ITEM	SYMB	MIN	TYP	MAX	UNIT	NOTE
LED Current	I _L	15	20	25	mA	(1)
Power Consumption	V _L	1.2	1.6	2.0	W	I _L =6mA

Note (1) The LEDs parallel type (Refer to 4.2)

4. Touch Screen Panel Specifications(TBD)

4.1 Electrical Characteristics

ITEM	MIN	TYP	MAX	UNIT	NOTE
Linearity	-1.5	-	1.5	%	Analog X and Y directions
Terminal resistance	200	-	900	Ω	X
	200	-	900	Ω	Y
Insulation resistance	20	-	-	M Ω	DC 25V
Transmittance	-	80	-	%	JIS-K7105

Caution : Do not operate it with a thing except a polyacetal pen (tip R0.8mm or more) or a finger, especially those with hard or sharp tips such as a ball point pen or a mechanical pencil.

4.2 Mechanical & Reliability Characteristics

ITEM	MIN	TYP	MAX	UNIT	NOTE
Activation force	-	-	100	g	(1)
Durability (surface scratching)	Write	-	-	characters	(2)
	100,000	-	-		
Durability (surface pitting)	1,000,000	-	-	touches	(3)
		-	-		
Surface hardness	3	-	-	H	JIS_K5600

Note (1) Stylus pen Input : R0.8mm polyacetal pen or finger

(2) Measurement for Surface area

- Scratch 100,000 times straight line on the Film with a stylus change every 20,000 times

- Force : 250gf

- Speed : 70mm/sec

- Stylus : R0.8 polyacetal tip

(3) Pit 1,000,000 times on the Film with a R8.0 silicon rubber.

- Force : 250gf

- Speed : 2~3time/sec

4.3 Design Guide

- In order to prevent accidental use and performance deterioration, please keep the following precautions and inhibited points.

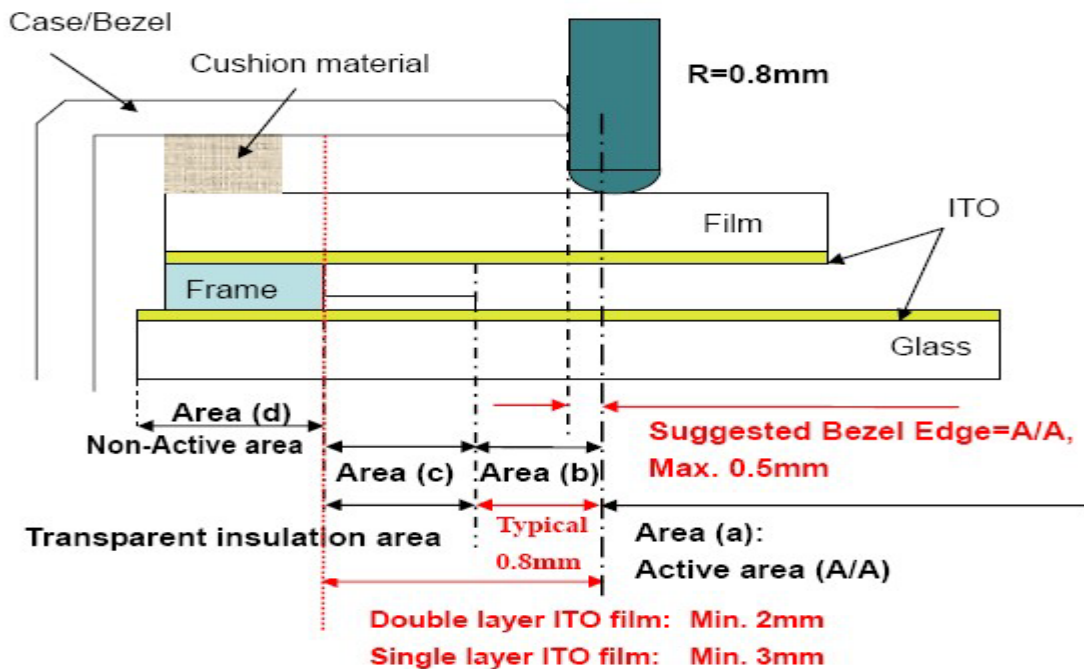

- Above figure illustrates the recommended bezel and cushion design. In order to prevent unusual performance degradation and malfunction of a touch panel, please carry out the set case designing and a touch panel assembling method after surely considering the definition of each area illustrated in above figure points.
- Area (a) : Active area
The active area is guaranteed the position data detectable precision, operation force and other operations. It is strongly recommended to place the operation button or menu keys within the active area. Due to structure, the active area is less durable at the edge or close to the edge.
- Area (b) : Operation non-guaranteed area
This area does not guarantee a touch panel operation and its function. When this area is pressed, touch panel shows degradation of its performance and durability such as a pen sliding durability becomes about one-tenth compared with the active area and its operation force requires about double. About 0.5mm outside from a boundary of the active area corresponds to this area.
- Area (c) : (Pressing prohibition area)
The area with forbids pressing, because an excessive load is applied to a transparent electrode (ITO) and a serious damage is given to a touch panel function by pressing.
- Area (d) : (Non-Active area)
The area does not activate even if pressed.

5. BLOCK DIAGRAM

5.1 TFT LCD MODULE

Connector : KN12LR-30P-1H or compatible

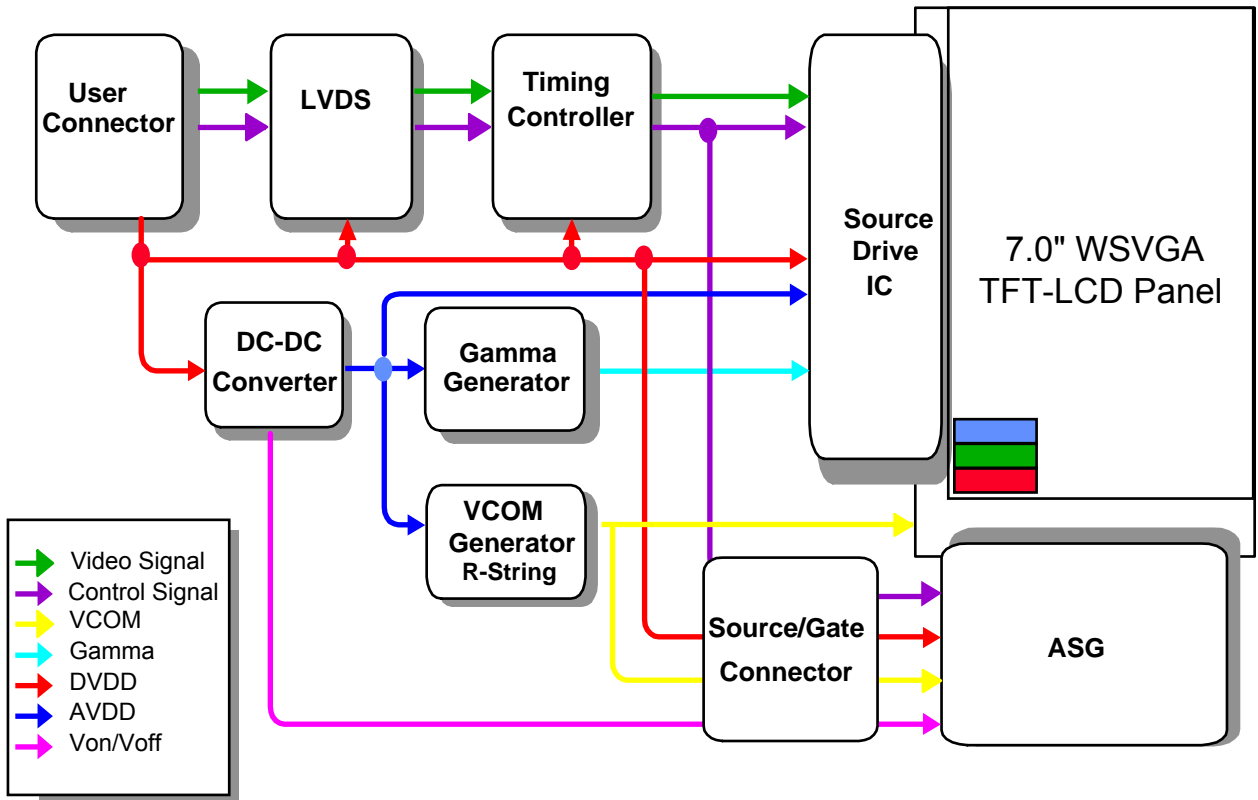

5.2 BACKLIGHT UNIT

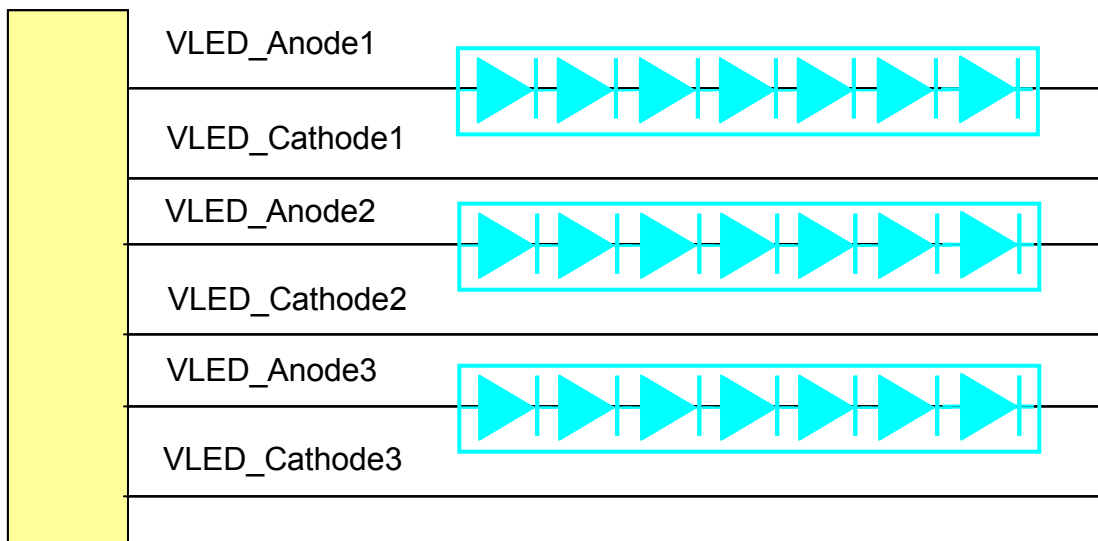

5.3 Touch Panel Unit

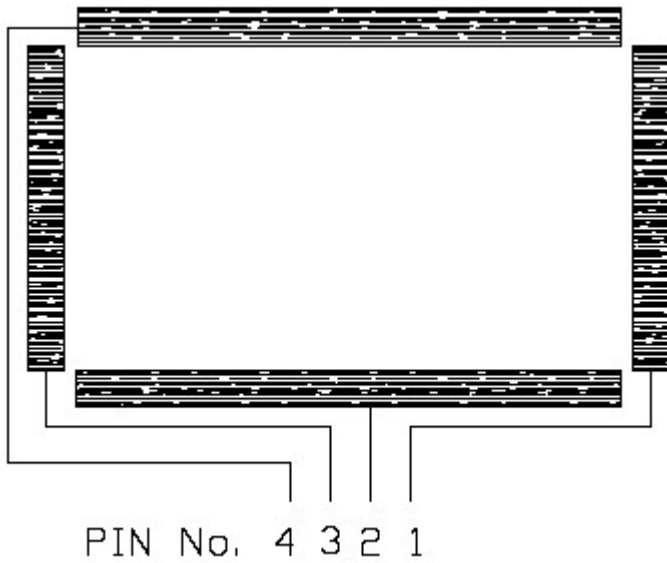

Top View

X : Film electrode
Y : Glass electrode

Pin No.	Symbol	Description
1	X _R	TSP RIGHT
2	Y _D	TSP DOWN
3	X _L	TSP LEFT
4	Y _U	TSP UPPER

Note) TSP FPC Connector : 51345-0439(molex : 4pin 0.5mm pitch)
or compatible connector is preferred

6. INPUT TERMINAL PIN ASSIGNMENT

6.1. Input Signal & Power (LVDS, Connector : KN12LR-30P-1H)

PIN NO	SYMBOL	FUNCTION	POLARITY	REMARK
1	GND	GROUND		
2	VDD	POWER SUPPLY +3.3V		
3	VDD	POWER SUPPLY +3.3V		
4	NC	NO CONNECT		
5	ADJ	LED BRIGHTNESS ADJUSTMENT		
6	NC	NO CONNECT		
7	NC	NO CONNECT		
8	RxIN0-	LVDS Differential Data INPUT	Negative	R0~R5,G0
9	RxIN0+	LVDS Differential Data INPUT	Positive	
10	GND	GROUND		
11	RxIN1-	LVDS Differential Data INPUT	Negative	G1~G5, B0,B1
12	RxIN1+	LVDS Differential Data INPUT	Positive	
13	GND	GROUND		
14	RxIN2-	LVDS Differential Data INPUT	Negative	B2~B5,Vs, Hs,DE
15	RxIN2+	LVDS Differential Data INPUT	Positive	
16	GND	GROUND		
17	RxCLK-	LVDS Differential Data INPUT	Negative	Clock
18	RxCLK+	LVDS Differential Data INPUT	Positive	
19	GND	GROUND		
20	NC	NO CONNECT		
21	NC	NO CONNECT		
22	GND	GROUND		
23	NC	NO CONNECT		
24	LED VDD	LED POWE SUPPLY		
25	LED VDD	LED POWE SUPPLY		
26	LED VDD	LED POWE SUPPLY		
27	NC	NO CONNECT		
28	GND	GROUND		
29	NC	NO CONNECT		
30	NC	NO CONNECT		

NOTE. ADJ (PIN NO.5 :LED BRIGHTNESS ADJUSTMENT)

1) LED Brightness Control

Apply PWM signal to ADJ pin and control the duty that could control the LED brightness from 0% to maximum 100%

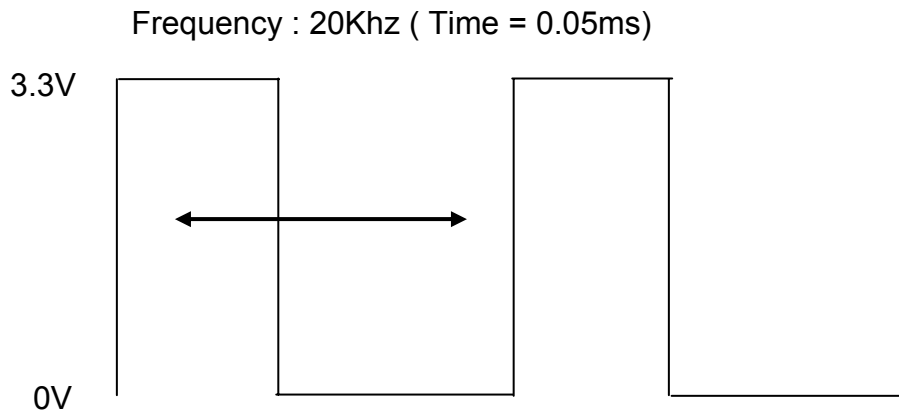

6.2 Timing Diagrams of LVDS For Transmission

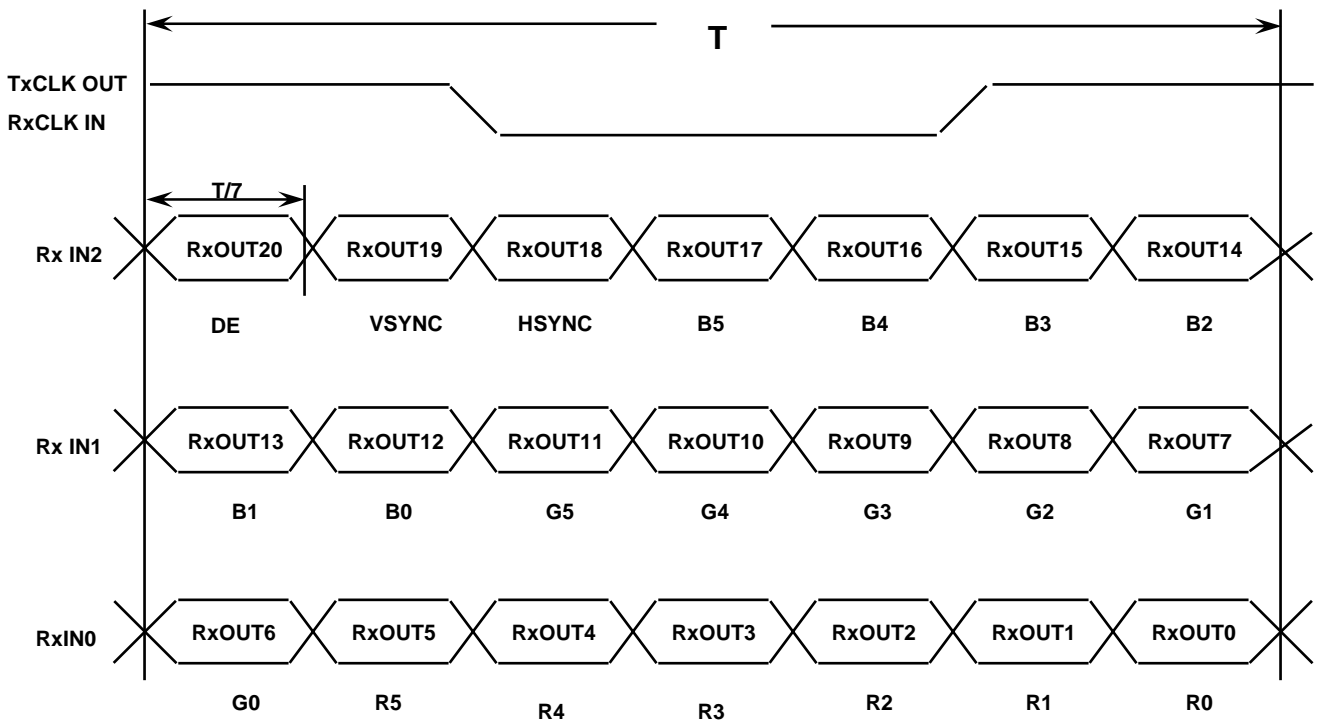

6.3 Input Signal, Basic Display Colors and Gray Scale of Each Colors

COLOR	DISPLAY	DATA SIGNAL																GRAY SCALE LEVEL		
		RED					GREEN					BLUE								
		R0	R1	R2	R3	R4	R5	G0	G1	G2	G3	G4	G5	B0	B1	B2	B3		B4	B5
BASIC COLOR	BLACK	0	0	0	0	0	0	0	0	0	0	0	0	0	0	0	0	0	0	-
	BLUE	0	0	0	0	0	0	0	0	0	0	0	0	1	1	1	1	1	1	-
	GREEN	0	0	0	0	0	0	1	1	1	1	1	1	0	0	0	0	0	0	-
	CYAN	0	0	0	0	0	0	1	1	1	1	1	1	1	1	1	1	1	1	-
	RED	1	1	1	1	1	1	0	0	0	0	0	0	0	0	0	0	0	0	-
	MAGENTA	1	1	1	1	1	1	0	0	0	0	0	0	1	1	1	1	1	1	-
	YELLOW	1	1	1	1	1	1	1	1	1	1	1	1	0	0	0	0	0	0	-
	WHITE	1	1	1	1	1	1	1	1	1	1	1	1	1	1	1	1	1	1	-
GRAY SCALE OF RED	BLACK	0	0	0	0	0	0	0	0	0	0	0	0	0	0	0	0	0	0	R0
	DARK ↑	1	0	0	0	0	0	0	0	0	0	0	0	0	0	0	0	0	0	R1
		0	1	0	0	0	0	0	0	0	0	0	0	0	0	0	0	0	0	R2
		:	:	:	:	:	:	:	:	:	:	:	:	:	:	:	:	:	:	R3~R60
	:	:	:	:	:	:	:	:	:	:	:	:	:	:	:	:	:	:		
	↓ LIGHT	1	0	1	1	1	1	0	0	0	0	0	0	0	0	0	0	0	0	R61
		0	1	1	1	1	1	0	0	0	0	0	0	0	0	0	0	0	0	R62
	RED	1	1	1	1	1	1	0	0	0	0	0	0	0	0	0	0	0	0	R63
GRAY SCALE OF GREEN	BLACK	0	0	0	0	0	0	0	0	0	0	0	0	0	0	0	0	0	0	G0
	DARK ↑	0	0	0	0	0	0	1	0	0	0	0	0	0	0	0	0	0	0	G1
		0	0	0	0	0	0	0	1	0	0	0	0	0	0	0	0	0	0	G2
		:	:	:	:	:	:	:	:	:	:	:	:	:	:	:	:	:	:	G3~G60
	:	:	:	:	:	:	:	:	:	:	:	:	:	:	:	:	:	:		
	↓ LIGHT	0	0	0	0	0	0	1	0	1	1	1	1	0	0	0	0	0	0	G61
		0	0	0	0	0	0	0	1	1	1	1	1	0	0	0	0	0	0	G62
	GREEN	0	0	0	0	0	0	1	1	1	1	1	1	0	0	0	0	0	0	G63
GRAY SCALE OF BLUE	BLACK	0	0	0	0	0	0	0	0	0	0	0	0	0	0	0	0	0	0	B0
	DARK ↑	0	0	0	0	0	0	0	0	0	0	0	0	1	0	0	0	0	0	B1
		0	0	0	0	0	0	0	0	0	0	0	0	0	1	0	0	0	0	B2
		:	:	:	:	:	:	:	:	:	:	:	:	:	:	:	:	:	:	B3~B60
	:	:	:	:	:	:	:	:	:	:	:	:	:	:	:	:	:	:		
	↓ LIGHT	0	0	0	0	0	0	0	0	0	0	0	0	1	0	1	1	1	1	B61
		0	0	0	0	0	0	0	0	0	0	0	0	0	1	1	1	1	1	B62
	BLUE	0	0	0	0	0	0	0	0	0	0	0	0	1	1	1	1	1	1	B63

Note

(1) Definition of Gray : Rn : Red Gray, Gn : Green Gray, Bn : Blue Gray (n = Gray level)

(2) Input Signal : 0 = Low level voltage, 1 = High level voltage

6.4 PIXEL FORMAT

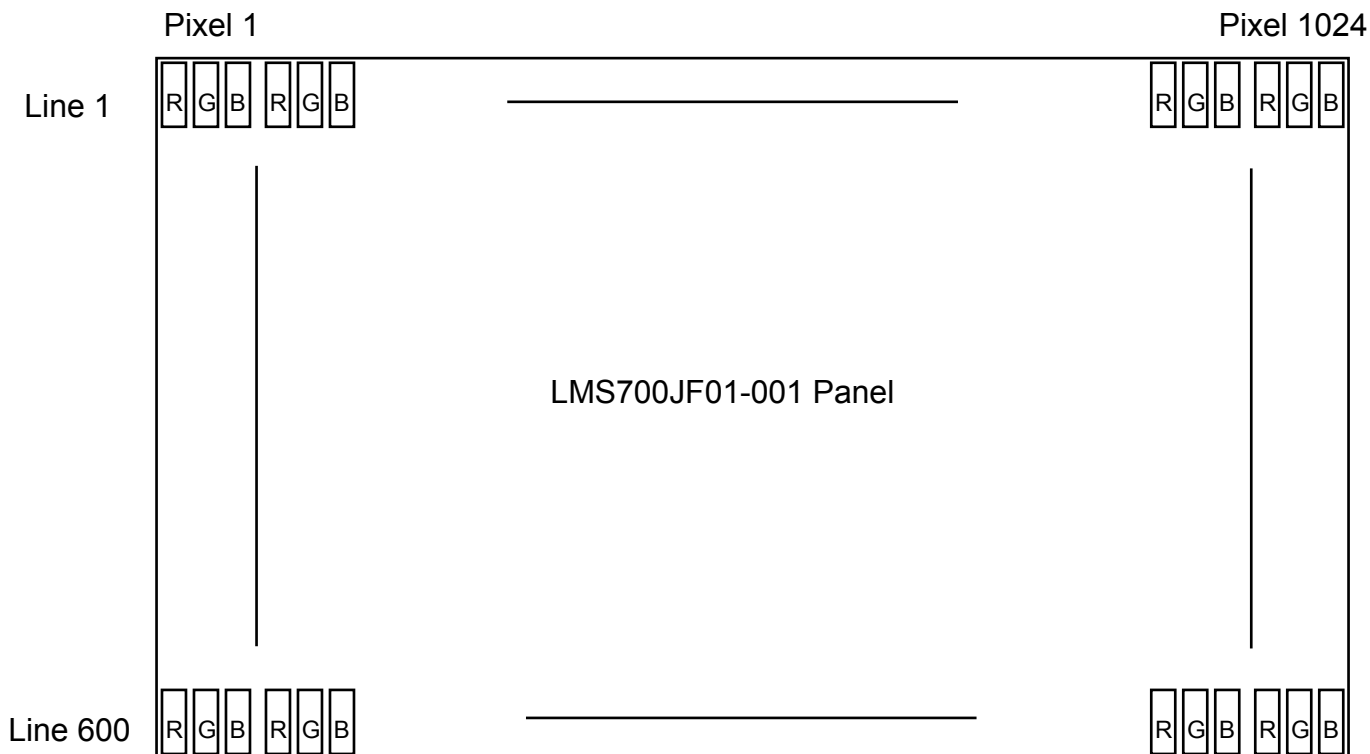

7. INTERFACE TIMING

7.1 Timing Parameters

SIGNAL	ITEM	SYMBOL	MIN.	TYP	MAX.	UNIT	NOTE
Clock	Frequency	1/TC	-	51.0	-	MHz	
	Clock Pulse Width	Tcw	7.84	-	11.76	nsec	
Data	Setup Time	TDS	2	-	-	nsec	
	Hold Time	TDH	0	-	-	nsec	
Frame Frequency	Cycle	TV	-	16.5	-	msec	
			-	60	-	Hz	
Vertical Active Display Term	Display Period	TVD	-	600	-	lines	
	Vertical Blank Period	TVB	-	26	-	lines	
One Line Scanning Time	Cycle	TH	-	1344	-	clocks	
Horizontal Active Display Term	Display Period	THD	-	1024	-	clocks	

7.2 Power ON/OFF Sequence (TBD)

: To prevent a latch-up or DC operation of the LCD module, the power on/off sequence should be as the diagram below.

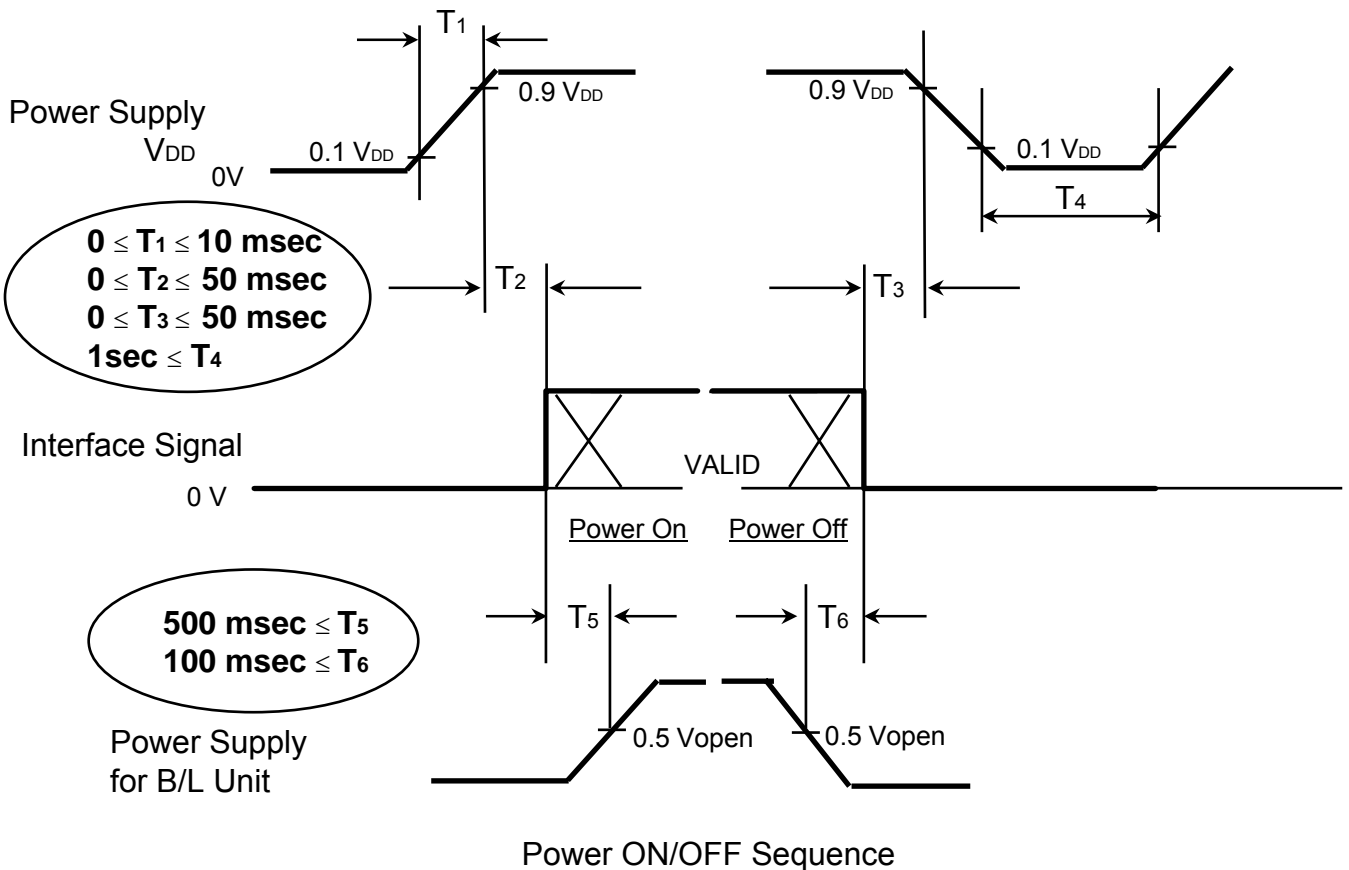

NOTE.

- (1) The supply voltage of the external system for the module input should be the same as the definition of V_{DD} .
- (2) Apply the lamp voltage within the LCD operation range. When the back-light turns on before the LCD operation or the LCD turns off before the back-light turns off, the display may momentarily become white.
- (3) In case of $V_{DD} = \text{off level}$, please keep the level of input signals on the low or keep a high impedance.
- (4) T_4 should be measured after the module has been fully discharged between power off and on period.
- (5) Interface signal shall not be kept at high impedance when the power is on.

8. Mechanical Outline Dimension

Preliminary

8.1 Front Side

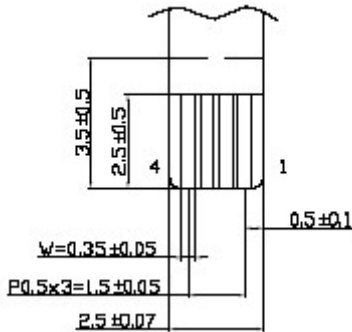
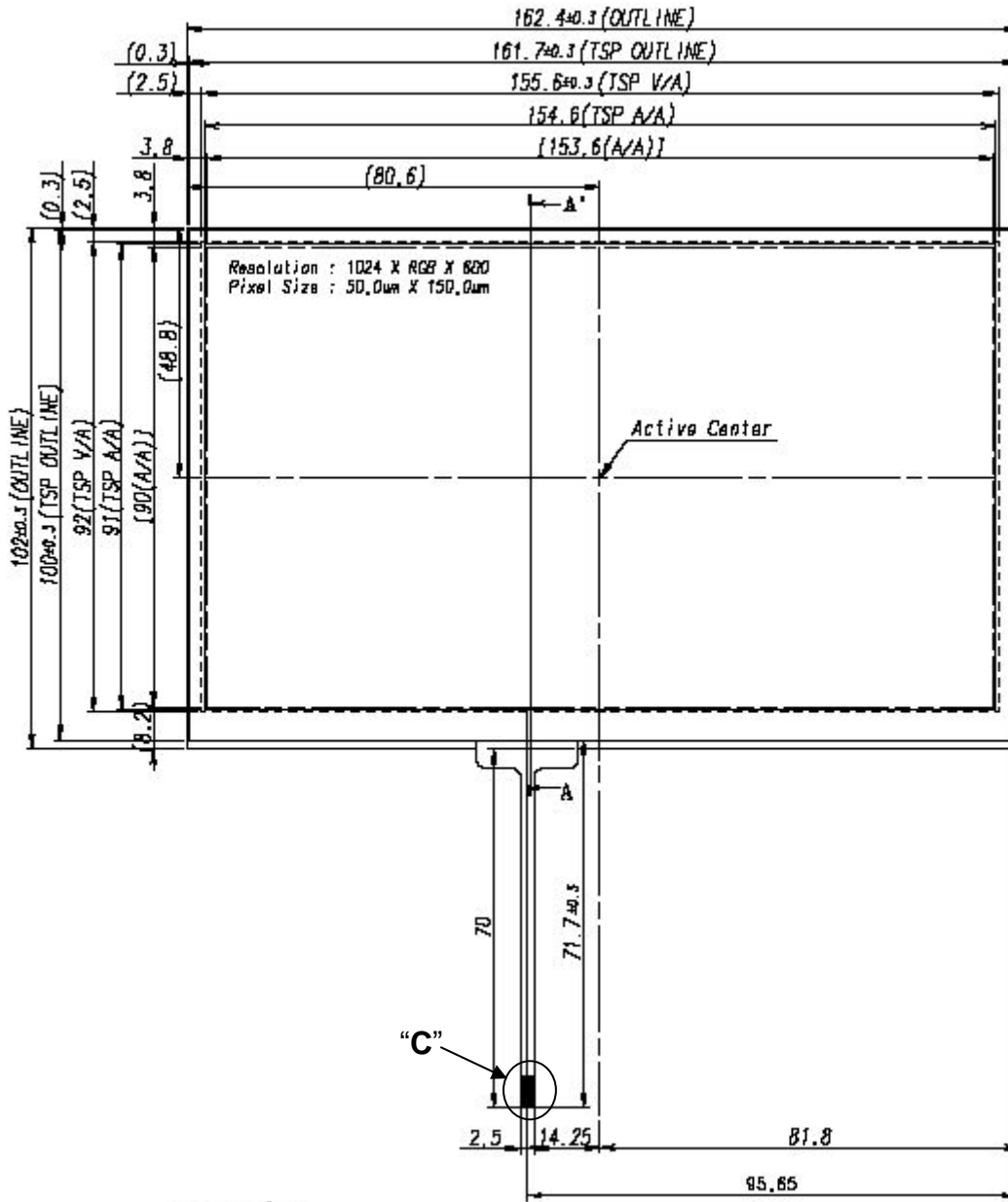

Detail "C"(TSP FPC)

8. Mechanical Outline Dimension

Preliminary

8.2 Rear Side

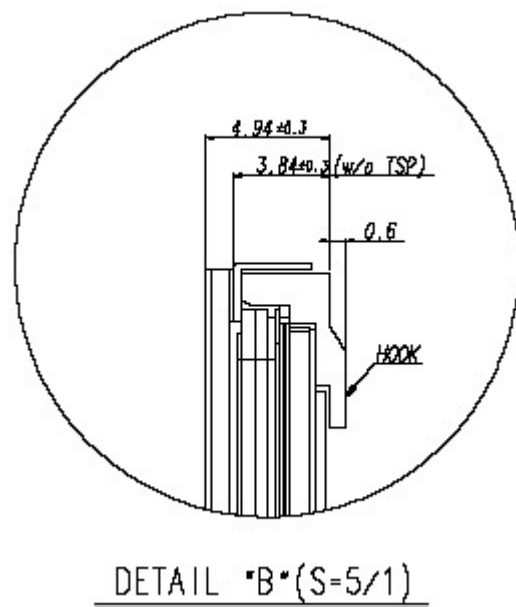
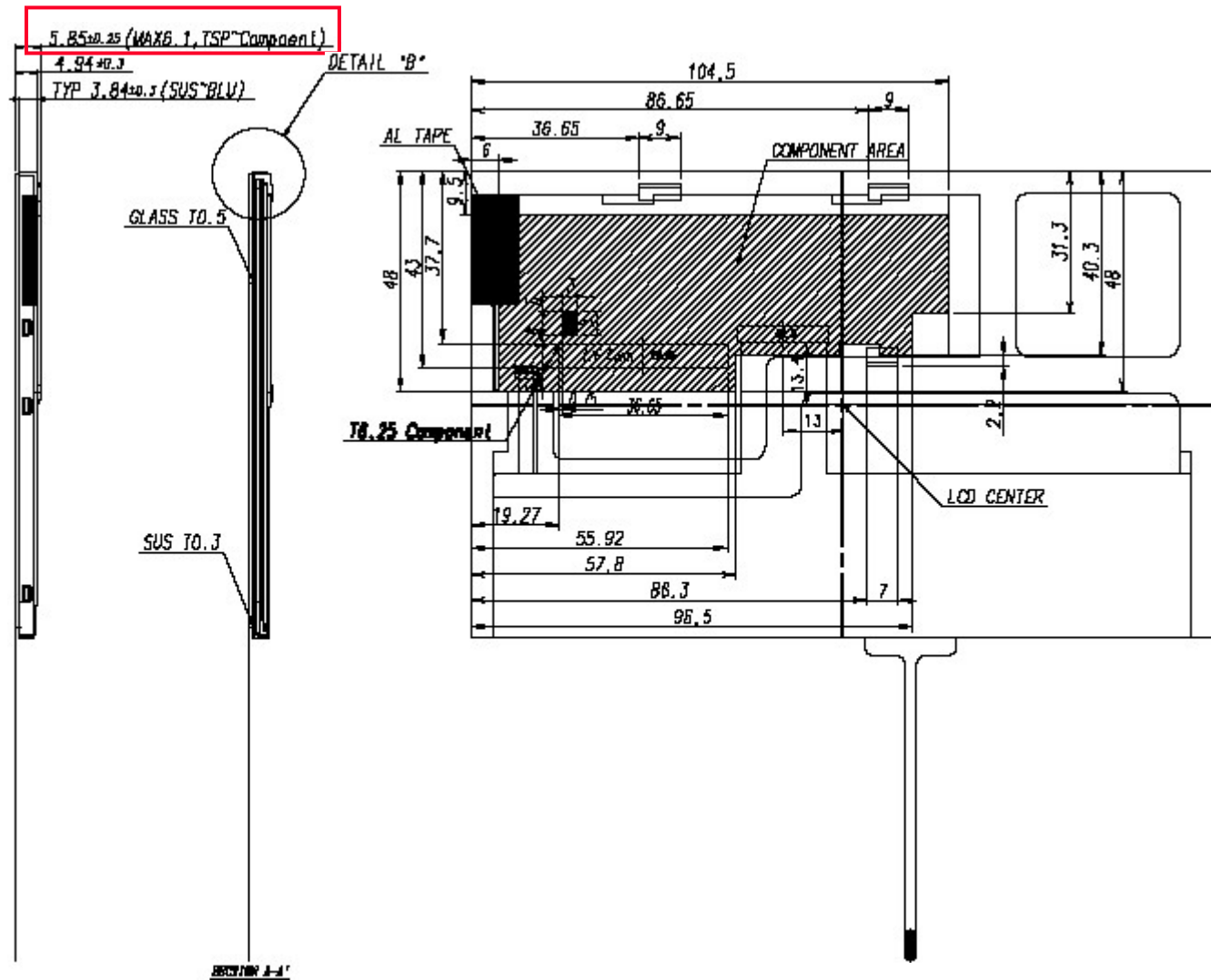

9. Packing

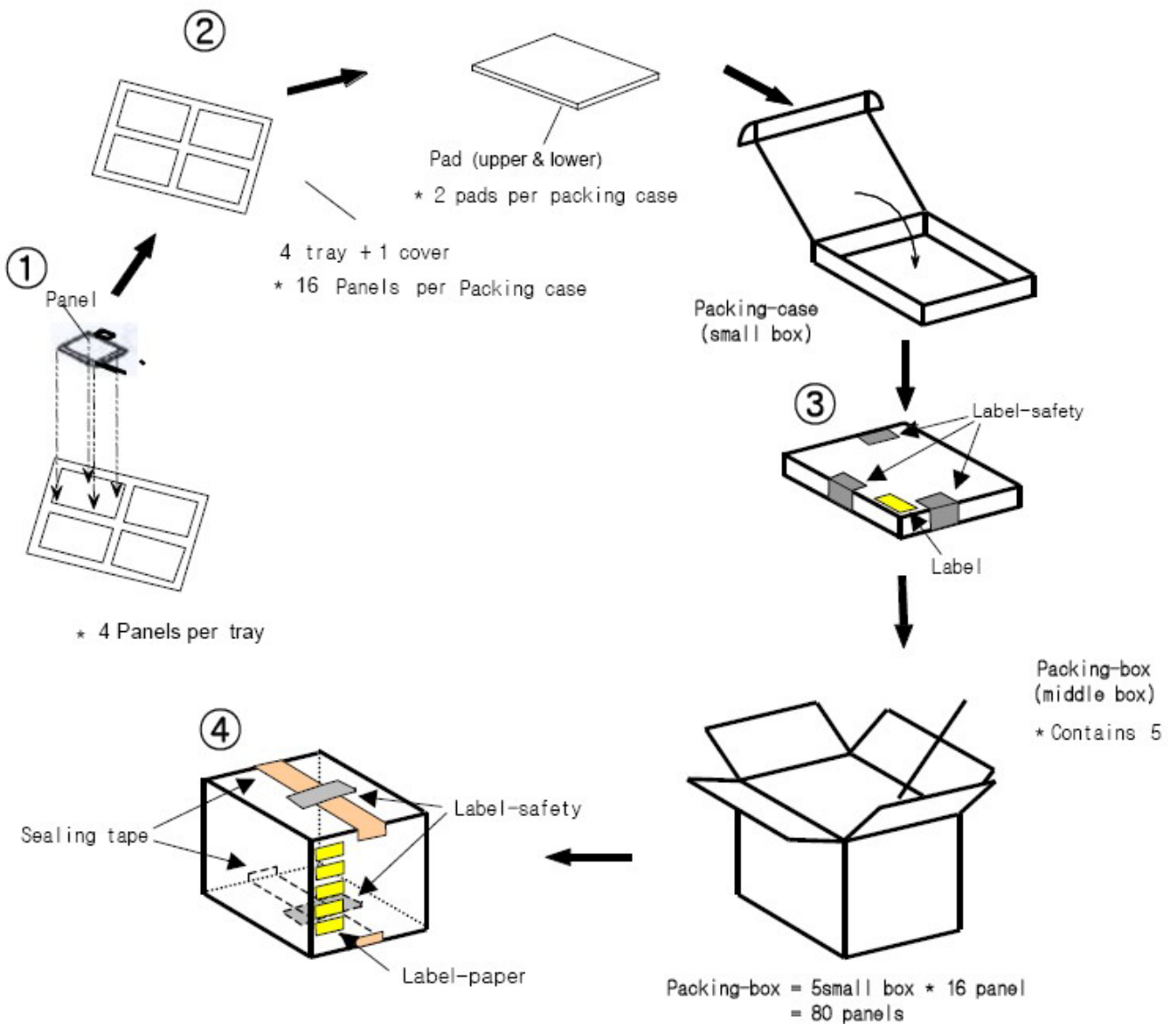

Note (1) Total : Case: Approx. TBD Kg
Box: Approx. TBD Kg

(2) Size : Case: 490(W) x 342(D) x 58(H)
Box: 505(W) x 355(D) x 312(H)

(3) Place the panels in the tray facing the direction shown in the figure.

(4) Place 4 tray and cover(empty tray) and pads inside the packing-case.

(5) Place 5 packing-case inside the packing-box.(Affix the label)

(6) Seal the packing-box. Affix the label-safety.

10. MARKINGS & OTHERS

A nameplate bearing followed by is affixed to a shipped product at the specified location on each product.

(1) Module attach

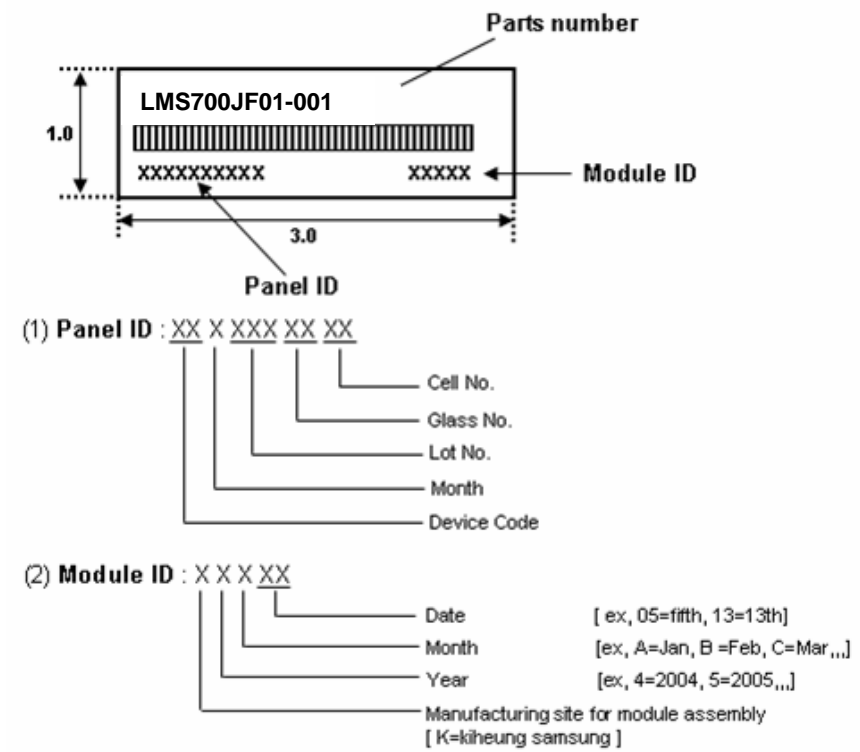

(2) Packing Case attach

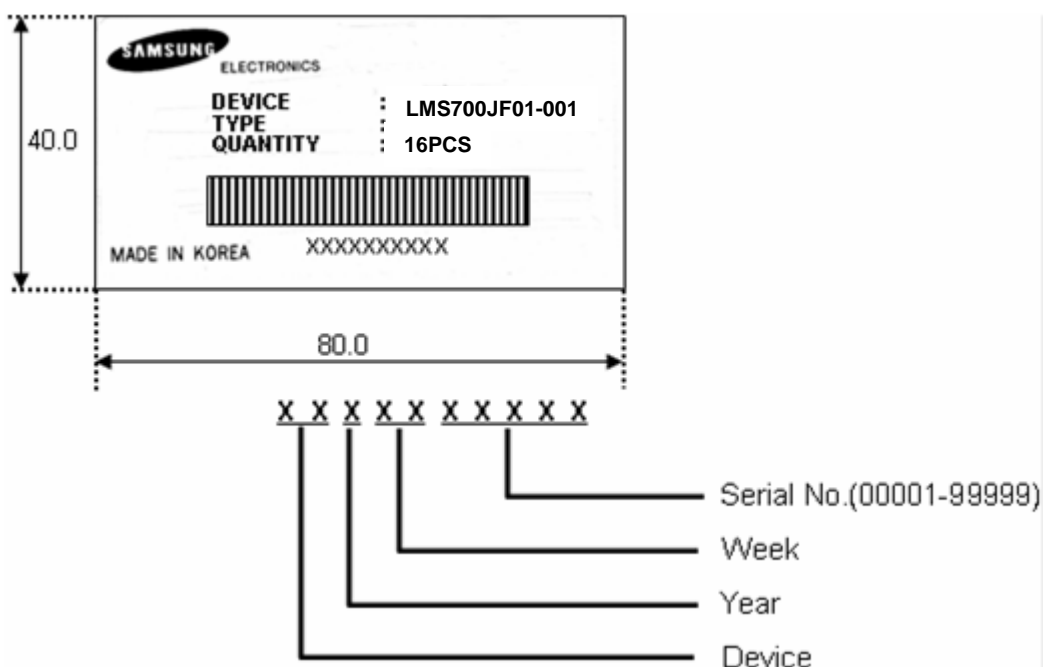

(3) Backlight Label

Lot number : X

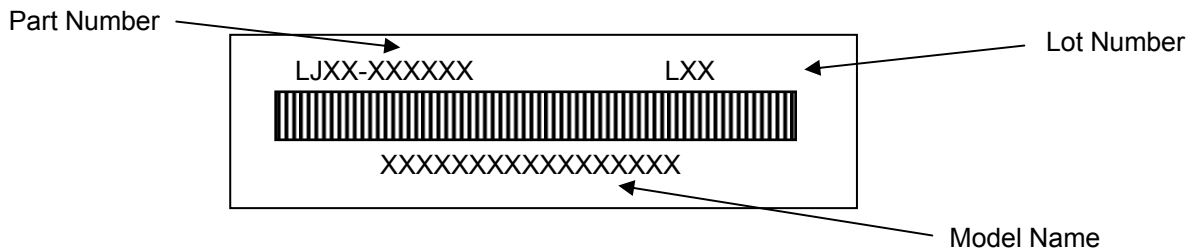
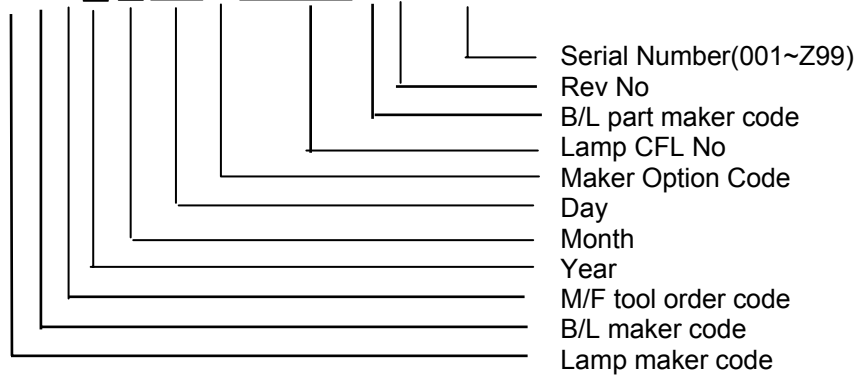

11. GENERAL PRECAUTIONS

1. Handling

- (a) When the module is assembled, It should be attached to the system firmly using every mounting holes. Be careful not to twist and bend the modules.
- (b) Refrain from strong mechanical shock and / or any force to the module. In addition to damage, this may cause improper operation or damage to the module and CCFT back-light.
- (c) Note that polarizers are very fragile and could be easily damaged. Do not press or scratch the surface harder than a HB pencil lead.
- (d) Wipe off water droplets or oil immediately. If you leave the droplets for a long time, Staining and discoloration may occur.
- (e) If the surface of the polarizer is dirty, clean it using some absorbent cotton or soft cloth.
- (f) The desirable cleaners are water, IPA(Isopropyl Alcohol) or Hexane. Do not use Ketone type materials(ex. Acetone), Ethyl alcohol, Toluene, Ethyl acid or Methyl chloride. It might permanent damage to the polarizer due to chemical reaction.
- (g) If the liquid crystal material leaks from the panel, it should be kept away from the eyes or mouth. In case of contact with hands, legs or clothes, it must be washed away thoroughly with soap.
- (h) Protect the module from static, it may cause damage to the C-MOS Gate Array IC.
- (i) Use finger-stalls with soft gloves in order to keep display clean during the incoming inspection and assembly process.
- (j) Do not disassemble the module.
- (k) Do not pull or fold the lamp wire.
- (l) Do not adjust the variable resistor which is located on the back side.
- (m) Protection film for polarizer on the module shall be slowly peeled off just before use so that the electrostatic charge can be minimized.
- (n) Pins of I/F connector shall not be touched directly with bare hands.

2. STORAGE

- (a) Do not leave the module in high temperature, and high humidity for a long time. It is highly recommended to store the module with temperature from 0 to 35 °C and relative humidity of less than 70%.
- (b) Do not store the TFT-LCD module in direct sunlight.
- (c) The module shall be stored in a dark place. It is prohibited to apply sunlight or fluorescent light during the store.

3. OPERATION

- (a) Do not connect, disconnect the module in the “ Power On” condition.
- (b) Power supply should always be turned on/off by following item 6.2 “ Power on/off sequence “.
- (c) Module has high frequency circuits. Sufficient suppression to the electromagnetic interference shall be done by system manufacturers. Grounding and shielding methods may be important to minimize the interference.
- (d) The cable between the back-light connector and its inverter power supply shall be a minimized length and be connected directly . The longer cable between the back-light and the inverter may cause lower luminance of lamp(CCFT) and may require higher startup voltage(Vs).

4. OTHERS

- (a) Ultra-violet ray filter is necessary for outdoor operation.
- (b) Avoid condensation of water. It may result in improper operation or disconnection of electrode.
- (c) Do not exceed the absolute maximum rating value. (the supply voltage variation, input voltage variation, variation in part contents and environmental temperature, so on) Otherwise the module may be damaged.
- (d) If the module displays the same pattern continuously for a long period of time, it can be the situation when the image “sticks” to the screen.
- (e) This module has its circuitry PCB's on the rear side and should be handled carefully in order not to be stressed.