



- CONTENTS -

REVISION HISTORY	-----	3
1. GENERAL DESCRIPTION	-----	4
1.1 OVERVIEW		
1.2 FEATURES		
1.3 APPLICATION		
1.4 GENERAL SPECIFICATIONS		
1.5 MECHANICAL SPECIFICATIONS		
2. ABSOLUTE MAXIMUM RATINGS	-----	6
2.1 ABSOLUTE RATINGS OF ENVIRONMENT		
2.2 ELECTRICAL ABSOLUTE RATINGS		
2.2.1 TFT LCD MODULE		
2.2.2 LED CONVERTER		
3. ELECTRICAL CHARACTERISTICS	-----	8
3.1 RECOMMENDED OPERATING CONDITION		
3.2 BACKLIGHT UNIT		
4. BLOCK DIAGRAM	-----	11
4.1 TFT LCD MODULE		
5. INPUT TERMINAL PIN ASSIGNMENT	-----	12
5.1 LVDS I/O PIN ASSIGNMENT		
5.2 BACKLIGHT PIN ASSIGNMENT		
5.3 SCANNING DIRECTION		
5.4 COLOR DATA INPUT ASSIGNMENT		
6. INTERFACE TIMING	-----	16
6.1 TIMING CHARACTERISTICS		
6.2 LVDS INPUT DATA FORMAT		
6.3 POWER ON/OFF SEQUENCE		
7. OPTICAL CHARACTERISTICS	-----	19
7.1 TEST CONDITIONS		
7.2 OPTICAL SPECIFICATIONS		
8. RELIABILITY TEST	-----	22
8.1 RELIABILITY TEST CONDITION		
9. PACKAGING	-----	23
10. DEFINITION OF LABELS	-----	25
11. PRECAUTIONS	-----	26
12. MECHANICAL CHARACTERISTICS	-----	27

**REVISION HISTORY**

Version	Date	Section	Description
Ver 2.0	Oct. 30, '09	All	G070Y2-L01 Approval specification was first issued.
Ver 2.1	May.13, 10	1.4	Module Power Consumption from 3.56 W to 3.71 W
		3.2	Converter Power Supply Current from 0.25A to 0.263mA Converter Power Consumption from 3W to 3.15W Note(2) $I_L = 60 \text{ mA(Per EA)}$ change to $I_L = 55 \text{ mA(Per EA)}$
		7.1	TEST CONDITIONS Current from $60 \pm 4 \text{ mA}$ to $55 \pm 3 \text{ mA}$
Ver 2.2	Sep. 9, 10	1.4	Module Power consumption 3.71W ->4.04W
		3.1	Power Supply Current   White 140mA -> 250mA Black 170mA -> 270mA
		3.2	Add Note(3)
Ver 2.3	Dec. 1, 10	6.1	Clock Frequency $1/T_{\text{clock}}$ : Min. 27 MHz -> 28 MHz Max. 33 MHz -> 32MHz

## 1. GENERAL DESCRIPTION

### 1.1 OVERVIEW

G070Y2-L01 is a 7inch TFT Liquid Crystal Display module with a LED backlight unit and a-20pin 6/8bit LVDS interface controller board. The converter for the LED Backlight Unit is built in. This module supports 800 (R.G.B) x 480 WVGA mode which main application is the automotive display and industrial field.

### 1.2 FEATURES

- Wide viewing angle.
- Fast response time
- Wide operating temperature
- Reversible scan function
- 6/8 bit convertible
- High Color gamut ( NTSC : 72% )

### 1.3 APPLICATION

- Automotive Display
- Industry Application

### 1.4 GENERAL SPECIFICATIONS

Item	Specification	Unit	Note
Diagonal Size	7	inch	
Active Area	152.4x91.44	mm	(1)
Bezel Opening Area	154.6x93.64	mm	
Driver Element	a-si TFT active matrix	-	-
Pixel Number	800 x R.G.B. x 480	pixel	-
Pixel Pitch	0.1905 x 0.1905	mm	-
Pixel Arrangement	RGB vertical stripe	-	(2)
Display Colors	262k or 16.2M	color	-
Display Mode	Normal White	-	-
Surface Treatment	Anti-glare, Hard Coating ( 3H )	-	-
Module Power Consumption	4.04	W	Typ.

Note (1) Please refer to the attached drawings for more information of front and back outline dimensions.

Note (2)

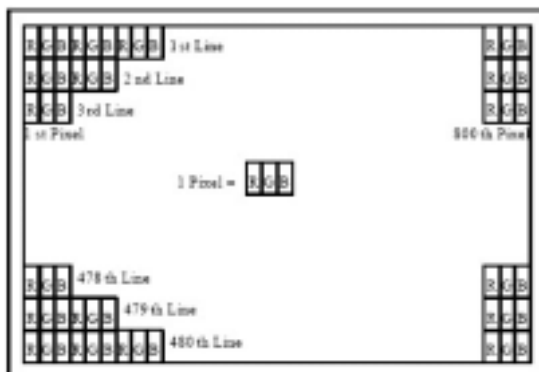

### 1.5 MECHANICAL SPECIFICATIONS

Item		Min.	Typ.	Max.	Unit	Note
Module Size	Horizontal (H)	164.3	165	165.3	mm	(1)
	Vertical (V)	103.3	104	104.3	mm	
	Depth (D)	9.03	9.53	10.03	mm	
Weight			147	162	g	

Note (1) Please refer to the attached drawings for more information of front and back outline dimensions.

2. ABSOLUTE MAXIMUM RATINGS

2.1 ABSOLUTE RATINGS OF ENVIRONMENT

Item	Symbol	Value		Unit	Note
		Min.	Max.		
Operating Ambient Temperature	T <sub>OP</sub>	-30	+85	°C	
Storage Temperature	T <sub>ST</sub>	-40	+95	°C	

Note (1) Temperature and relative humidity range is shown in the figure below.

(2) Wet-bulb temperature should be 39 °C Max. (Ta > 40 °C).

(3) No condensation.

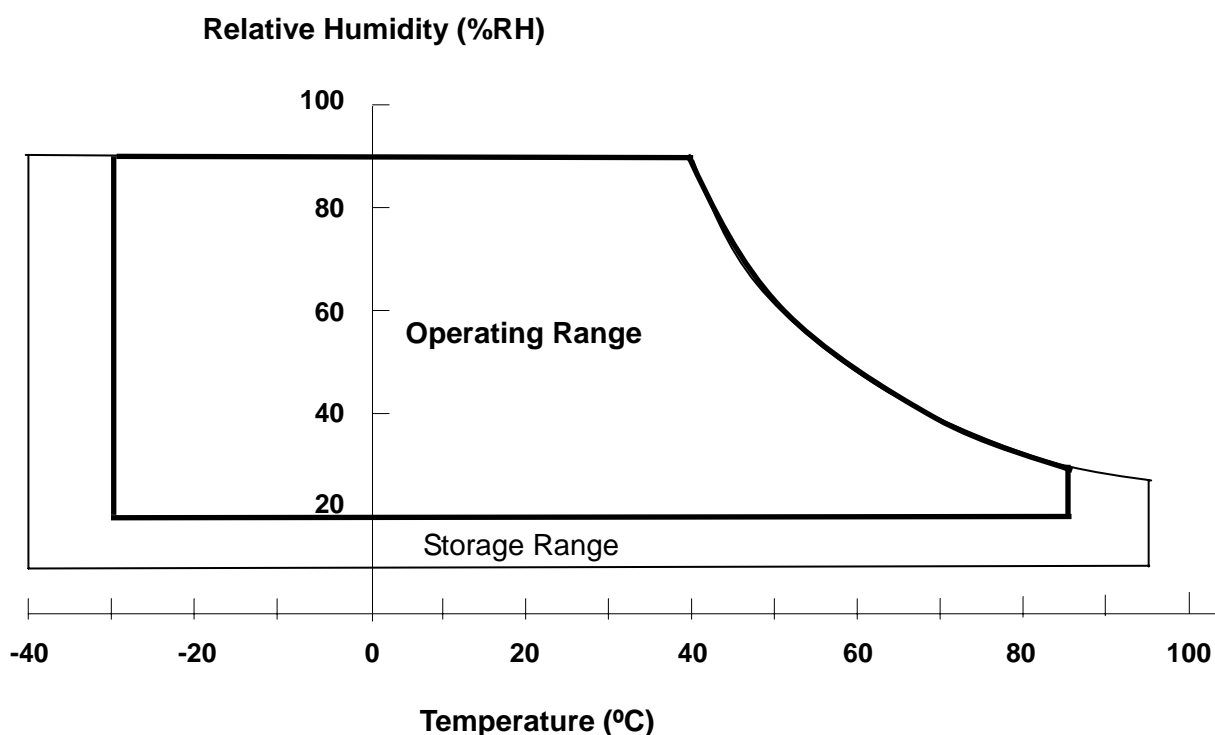

## 2.2 ELECTRICAL ABSOLUTE RATINGS

### 2.2.1 TFT LCD MODULE

Ta = 25 ± 2 °C

Item	Symbol	Value		Unit	Note
		Min.	Max.		
Power Supply Voltage	Vcc	-0.3	4	V	(1)

### 2.2.2 LED CONVERTER

Item	Symbol	Value		Unit	Note
		Min.	Max.		
Converter Voltage	V <sub>i</sub>	-0.3	18	V	(1), (2)
Enable Voltage	EN	---	4	V	
Backlight Adjust	ADJ	---	3.3	V	

Note (1) Permanent damage to the device may occur if maximum values are exceeded. Function operation should be restricted to the conditions described under Normal Operating Conditions.

Note (2) Specified values are for LED converter (Refer to 3.2 for further information).

3. ELECTRICAL CHARACTERISTICS

3.1 RECOMMENDED OPERATION CONDITION

Ta = 25 ± 2 °C

Parameter	Symbol	Value			Unit	Note
		Min.	Typ.	Max.		
Power Supply Voltage	Vcc	3.0	3.3	3.6	V	(1)
Rush Current	IRUSH			1.5	A	(2)
Power Supply Current	White		250		mA	(3)a
	Black		270		mA	(3)b
LVDS Differential Input High Threshold	V <sub>TH(LVDS)</sub>			100	mV	-
LVDS Differential Input Low Threshold	V <sub>TL(LVDS)</sub>	-100			mV	-
LVDS Common Mode Voltage	V <sub>CM</sub>		1.2		V	-

Note (1) The assembly should be always operated within above ranges.

Note (2) Measurement Conditions:

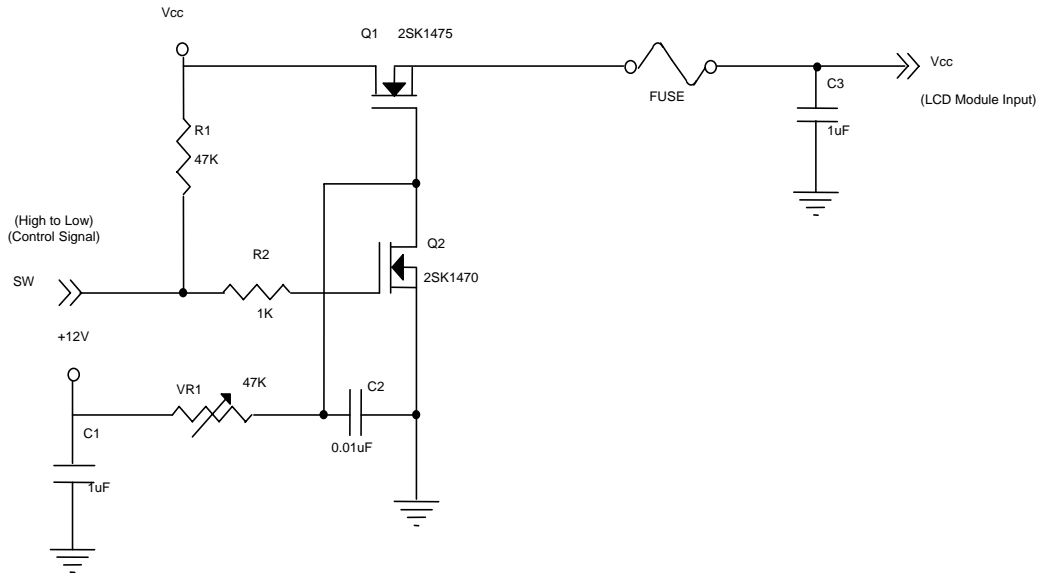

**Vcc rising time is 470µs**

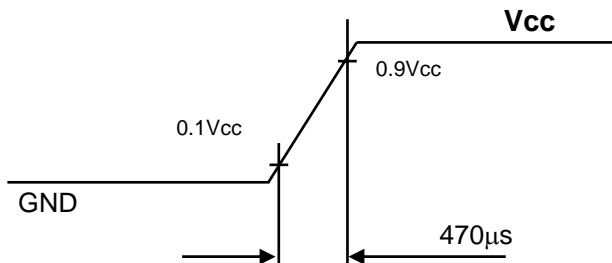



Note (3) The specified power supply current is under the conditions at  $V_{cc} = 3.3V$  ,  $T_a = 25 \pm 2 \text{ }^\circ\text{C}$ ,  $f_v = 60$  Hz, whereas a power dissipation check pattern below is displayed.

a. White Pattern

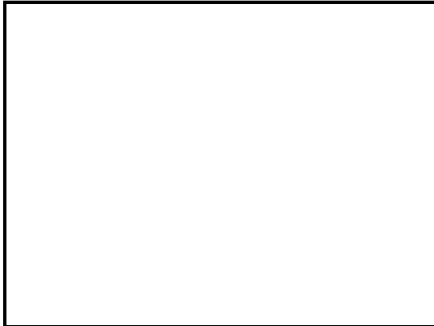

Active Area

b. Black Pattern

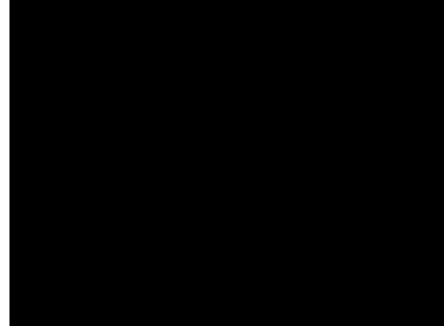

Active Area

3.2 BACKLIGHT UNIT

Ta = 25 ± 2 °C

Parameter	Symbol	Value			Unit	Note
		Min.	Typ.	Max.		
Converter Power Supply Voltage	$V_i$	10.8	12.0	13.2	V	
Converter Power Supply Current	$I_i$	---	0.263	---	A	@ $V_i = 12V$ (Duty 100%)
Converter Power Consumption	$P_{LED}$	---	3.15	---	W	@ $V_i = 12V$ (Duty 100%)
EN Control Level	Backlight on	2.0	---	3.3	V	
	Backlight off	0	---	0.8	V	
PWM Control Level	PWM High Level	2.0	---	3.3	V	
	PWM Low Level	0	---	0.15	V	
PWM Control Duty Ratio		20		100	%	
PWM Control Frequency	$f_{PWM}$	190	200	210	Hz	
LED Life Time	$L_L$	50,000			Hrs	(2)

Note (1) LED current is measured by utilizing a high frequency current meter as shown below:

Note (2) The lifetime of LED is defined as the time when it continues to operate under the conditions at  $T_a = 25 \pm 2$  and  $I_{LED} = 55mA_{DC}$  (LED forward current) until the brightness becomes 50% of its original value.

Note (3) Please note that LED life will be shorter than the average life described in the specification if operate in higher ambient temperature.

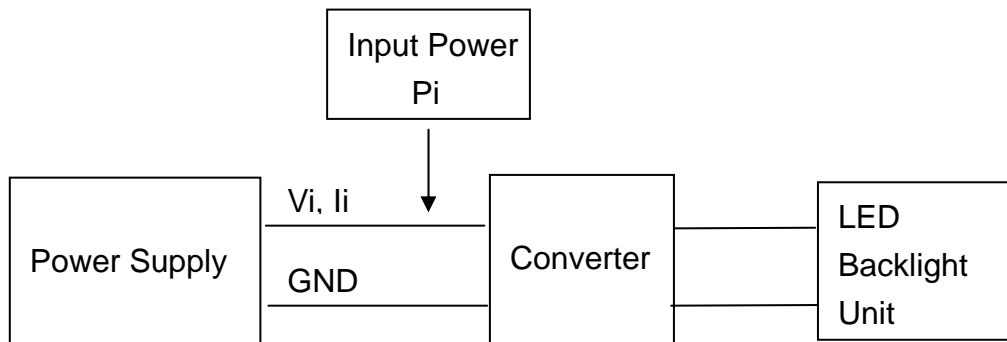

4. BLOCK DIAGRAM

4.1 TFT LCD MODULE

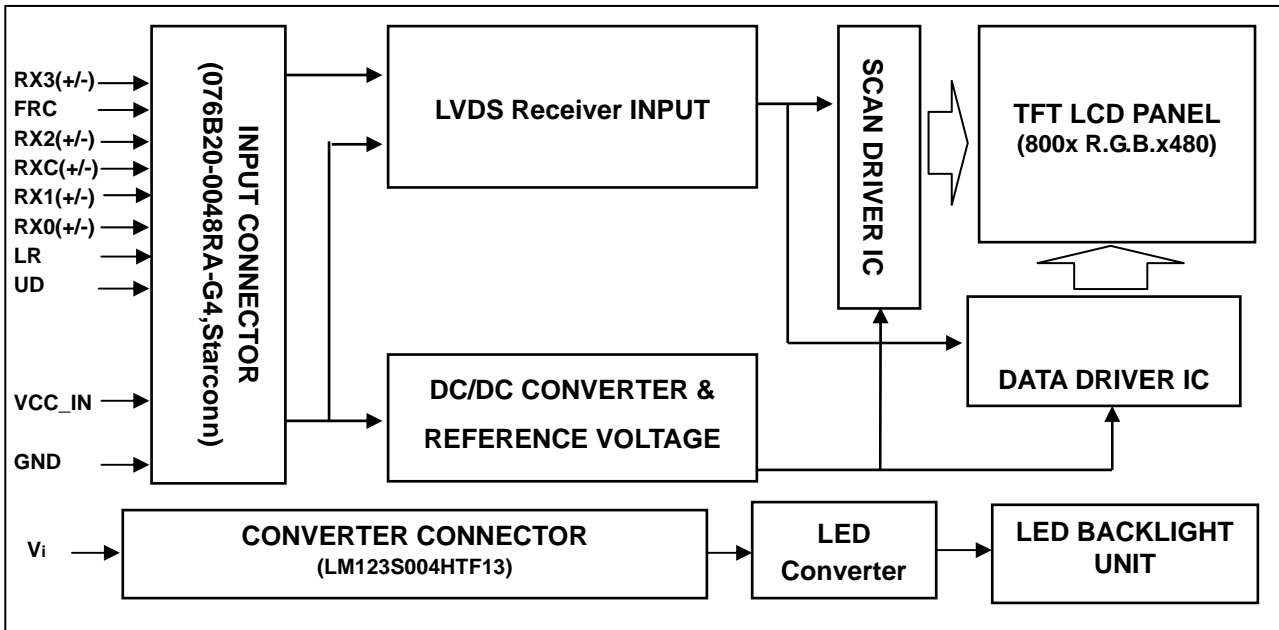

## 5. INPUT TERMINAL PIN ASSIGNMENT

### 5.1 LVDS I/O PIN ASSIGNMENT

Pin	Name	I/O	Description
1	RX3+	I	LVDS differential data input Pair 3.
2	RX3-	I	
3	NC	I	No Connected
4	FRC	I	Dithering control setting When FRC=H, the width of data input 8 bits When FRC=L, the width of data input 6 bits and set Dx0 and Dx1 to logical low (Default pull low)
5	GND	I	Ground
6	RXC+	I	LVDS differential Clock input Pair
7	RXC-	I	
8	GND	I	Ground
9	RX2+	I	LVDS differential data input Pair 2
10	RX2-	I	
11	GND	I	Ground
12	RX1+	I	LVDS differential data input Pair 1
13	RX1-	I	
14	GND	I	Ground
15	RX0+	I	LVDS differential data input Pair 0
16	RX0-	I	
17	LR	I	Shift direction of Source Driver IC internal shift register is controlled by this pin as show below: LR=H SO1→ .....SO1200 (Default pull high) LR=L SO1200→ .....SO1
18	UD	I	Gate Driver Up/down scan setting When UD=H, reverse scan When UD=L, normal scan (Default pull low)
19	VCC_IN	I	Digital power supply (+3.3V)
20	VCC_IN	I	Digital power supply (+3.3V)

Note (1) User's connector Part No.: 076B20-0048RA-G4, Starconn or equivalent

### 5.2 BACKLIGHT PIN ASSIGNMENT (Converter connector pin)

No	Symbol	I/O	Description
1	Vi	I	Converter input voltage
2	ADJ	I	Backlight Adjust
3	EN	I	Enable pin
4	V <sub>GND</sub>		Converter ground

Note (1) User's connector Part No: LM123S004HTF13,4 PIN,UNE

5.3 SCANNING DIRECTION

The following figures show the image see from the front view. The arrow indicates the direction of scan.

Fig.1 Normal Scan



Fig.2 Reverse Scan



Fig.3 Reverse Scan

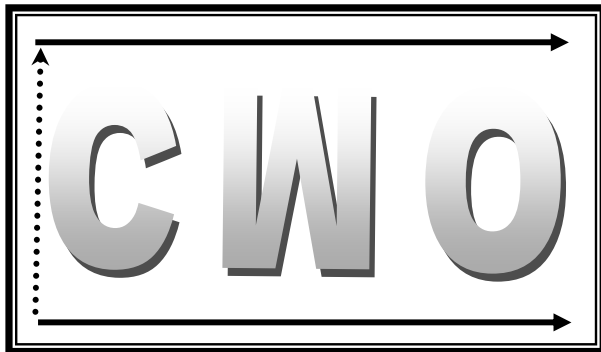

Fig.4 Reverse Scan



Fig. 1 Normal scan ( pin 17, LR = High ; pin 18, UD = Low )

Fig. 2 Reverse scan ( pin 17, LR = Low ; pin 18, UD = Low )

Fig. 3 Reverse scan ( pin 17, LR = High ; pin 18, UD = High )

Fig. 4 Reverse scan ( pin 17, LR = Low ; pin 18, UD = High )

**5.4 COLOR DATA INPUT ASSIGNMENT**

The brightness of each primary color (red, green and blue) is based on the 6-bit gray scale data input for the color. The higher the binary input, the brighter the color. The table below provides the assignment of color versus data input. ( 0: Low Level Voltage, 1: High Level Voltage)

Color		Data Signal																	
		Red						Green						Blue					
		R5	R4	R3	R2	R1	R0	G5	G4	G3	G2	G1	G0	B5	B4	B3	B2	B1	B0
Basic Colors	Black	0	0	0	0	0	0	0	0	0	0	0	0	0	0	0	0	0	0
	Red	1	1	1	1	1	1	0	0	0	0	0	0	0	0	0	0	0	0
	Green	0	0	0	0	0	0	1	1	1	1	1	1	0	0	0	0	0	0
	Blue	0	0	0	0	0	0	0	0	0	0	0	0	1	1	1	1	1	1
	Cyan	0	0	0	0	0	0	1	1	1	1	1	1	1	1	1	1	1	1
	Magenta	1	1	1	1	1	1	0	0	0	0	0	0	1	1	1	1	1	1
	Yellow	1	1	1	1	1	1	1	1	1	1	1	1	0	0	0	0	0	0
	White	1	1	1	1	1	1	1	1	1	1	1	1	1	1	1	1	1	1
Gray Scale Of Red	Red(0) / Dark	0	0	0	0	0	0	0	0	0	0	0	0	0	0	0	0	0	0
	Red(1)	0	0	0	0	0	1	0	0	0	0	0	0	0	0	0	0	0	0
	Red(2)	0	0	0	0	1	0	0	0	0	0	0	0	0	0	0	0	0	0
	⋮	⋮	⋮	⋮	⋮	⋮	⋮	⋮	⋮	⋮	⋮	⋮	⋮	⋮	⋮	⋮	⋮	⋮	⋮
	⋮	⋮	⋮	⋮	⋮	⋮	⋮	⋮	⋮	⋮	⋮	⋮	⋮	⋮	⋮	⋮	⋮	⋮	⋮
	Red(61)	1	1	1	1	0	1	0	0	0	0	0	0	0	0	0	0	0	0
	Red(62)	1	1	1	1	1	0	0	0	0	0	0	0	0	0	0	0	0	0
	Red(63)	1	1	1	1	1	1	0	0	0	0	0	0	0	0	0	0	0	0
Gray Scale Of Green	Green(0) / Dark	0	0	0	0	0	0	0	0	0	0	0	0	0	0	0	0	0	0
	Green(1)	0	0	0	0	0	0	0	0	0	0	0	1	0	0	0	0	0	0
	Green(2)	0	0	0	0	0	0	0	0	0	0	1	0	0	0	0	0	0	0
	⋮	⋮	⋮	⋮	⋮	⋮	⋮	⋮	⋮	⋮	⋮	⋮	⋮	⋮	⋮	⋮	⋮	⋮	⋮
	⋮	⋮	⋮	⋮	⋮	⋮	⋮	⋮	⋮	⋮	⋮	⋮	⋮	⋮	⋮	⋮	⋮	⋮	⋮
	Green(61)	0	0	0	0	0	0	1	1	1	1	0	1	0	0	0	0	0	0
	Green(62)	0	0	0	0	0	0	1	1	1	1	1	0	0	0	0	0	0	0
	Green(63)	0	0	0	0	0	0	1	1	1	1	1	1	0	0	0	0	0	0
Gray Scale Of Blue	Blue(0) / Dark	0	0	0	0	0	0	0	0	0	0	0	0	0	0	0	0	0	0
	Blue(1)	0	0	0	0	0	0	0	0	0	0	0	0	0	0	0	0	0	1
	Blue(2)	0	0	0	0	0	0	0	0	0	0	0	0	0	0	0	0	1	0
	⋮	⋮	⋮	⋮	⋮	⋮	⋮	⋮	⋮	⋮	⋮	⋮	⋮	⋮	⋮	⋮	⋮	⋮	⋮
	⋮	⋮	⋮	⋮	⋮	⋮	⋮	⋮	⋮	⋮	⋮	⋮	⋮	⋮	⋮	⋮	⋮	⋮	⋮
	Blue(61)	0	0	0	0	0	0	0	0	0	0	0	0	1	1	1	1	0	1
	Blue(62)	0	0	0	0	0	0	0	0	0	0	0	0	1	1	1	1	1	0
	Blue(63)	0	0	0	0	0	0	0	0	0	0	0	0	1	1	1	1	1	1

The brightness of each primary color (red, green and blue) is based on the 8-bit gray scale data input for the color. The higher the binary input, the brighter the color. The table below provides the assignment of color versus data input.

( 0: Low Level Voltage, 1: High Level Voltage)

Color		Data Signal																						
		Red								Green								Blue						
		R7	R6	R5	R4	R3	R2	R1	R0	G7	G6	G5	G4	G3	G2	G1	G0	B7	B6	B5	B4	B3	B2	B1
Basic Colors	Black	0	0	0	0	0	0	0	0	0	0	0	0	0	0	0	0	0	0	0	0	0	0	0
	Red	1	1	1	1	1	1	1	1	0	0	0	0	0	0	0	0	0	0	0	0	0	0	0
	Green	0	0	0	0	0	0	0	0	1	1	1	1	1	1	1	1	0	0	0	0	0	0	0
	Blue	0	0	0	0	0	0	0	0	0	0	0	0	0	0	0	0	1	1	1	1	1	1	1
	Cyan	0	0	0	0	0	0	0	0	1	1	1	1	1	1	1	1	1	1	1	1	1	1	1
	Magenta	1	1	1	1	1	1	1	1	0	0	0	0	0	0	0	0	1	1	1	1	1	1	1
	Yellow	1	1	1	1	1	1	1	1	1	1	1	1	1	1	1	1	0	0	0	0	0	0	0
	White	1	1	1	1	1	1	1	1	1	1	1	1	1	1	1	1	1	1	1	1	1	1	1
Gray Scale Of Red	Red(0) / Dark	0	0	0	0	0	0	0	0	0	0	0	0	0	0	0	0	0	0	0	0	0	0	
	Red(1)	0	0	0	0	0	0	0	1	0	0	0	0	0	0	0	0	0	0	0	0	0	0	
	Red(2)	0	0	0	0	0	0	1	0	0	0	0	0	0	0	0	0	0	0	0	0	0	0	
	:	:	:	:	:	:	:	:	:	:	:	:	:	:	:	:	:	:	:	:	:	:	:	
	:	:	:	:	:	:	:	:	:	:	:	:	:	:	:	:	:	:	:	:	:	:	:	
	Red(253)	1	1	1	1	1	1	0	1	0	0	0	0	0	0	0	0	0	0	0	0	0	0	
	Red(254)	1	1	1	1	1	1	1	0	0	0	0	0	0	0	0	0	0	0	0	0	0	0	
	Red(255)	1	1	1	1	1	1	1	1	0	0	0	0	0	0	0	0	0	0	0	0	0	0	
Gray Scale Of Green	Green(0)/ Dark	0	0	0	0	0	0	0	0	0	0	0	0	0	0	0	0	0	0	0	0	0	0	
	Green(1)	0	0	0	0	0	0	0	0	0	0	0	0	0	0	1	0	0	0	0	0	0	0	
	Green(2)	0	0	0	0	0	0	0	0	0	0	0	0	0	1	0	0	0	0	0	0	0	0	
	:	:	:	:	:	:	:	:	:	:	:	:	:	:	:	:	:	:	:	:	:	:	:	
	:	:	:	:	:	:	:	:	:	:	:	:	:	:	:	:	:	:	:	:	:	:	:	
	Green(253)	0	0	0	0	0	0	0	0	1	1	1	1	1	1	0	1	0	0	0	0	0	0	
	Green(254)	0	0	0	0	0	0	0	0	1	1	1	1	1	1	1	0	0	0	0	0	0	0	
	Green(255)	0	0	0	0	0	0	0	0	1	1	1	1	1	1	1	1	0	0	0	0	0	0	
Gray Scale Of Blue	Blue(0) / Dark	0	0	0	0	0	0	0	0	0	0	0	0	0	0	0	0	0	0	0	0	0	0	
	Blue(1)	0	0	0	0	0	0	0	0	0	0	0	0	0	0	0	0	0	0	0	0	0	1	
	Blue(2)	0	0	0	0	0	0	0	0	0	0	0	0	0	0	0	0	0	0	0	0	0	1	
	:	:	:	:	:	:	:	:	:	:	:	:	:	:	:	:	:	:	:	:	:	:	:	
	:	:	:	:	:	:	:	:	:	:	:	:	:	:	:	:	:	:	:	:	:	:	:	
	Blue(253)	0	0	0	0	0	0	0	0	0	0	0	0	0	0	0	1	1	1	1	1	1	0	
	Blue(254)	0	0	0	0	0	0	0	0	0	0	0	0	0	0	0	1	1	1	1	1	1	1	
	Blue(255)	0	0	0	0	0	0	0	0	0	0	0	0	0	0	0	1	1	1	1	1	1	1	

6. INTERFACE TIMING

6.1 TIMING CHARACTERISTICS

The input signal timing specifications are shown as the following table and timing diagram

Parameter	Symbol	Value			Unit	Note	
		Min.	Typ.	Max.			
Vertical Display	Period	$T_v$	490	500	550	$T_h$	$T_v=T_{vd}+T_{vb}$
	Active	$T_{vd}$	-	480	-	$T_h$	-
	Blanking	$T_{vb}$	10	20	70	$T_h$	-
Horizontal Display	Period	$T_h$	930	992	1090	Tclock	$T_h=T_{hd}+T_{hb}$
	Active	$T_{hd}$	-	800	-	Tclock	-
	Blanking	$T_{hb}$	130	192	290	Tclock	-
Clock Frequency		$1/T_{clock}$	28	29.5	32	MHz	-

Note (1) Since this assembly is operated in DE only mode, Hsync and Vsync input signals should be set to low logic level. Otherwise, this assembly would operate abnormally.

(2) Frame rate is 60Hz

**INPUT SIGNAL TIMING DIAGRAM**

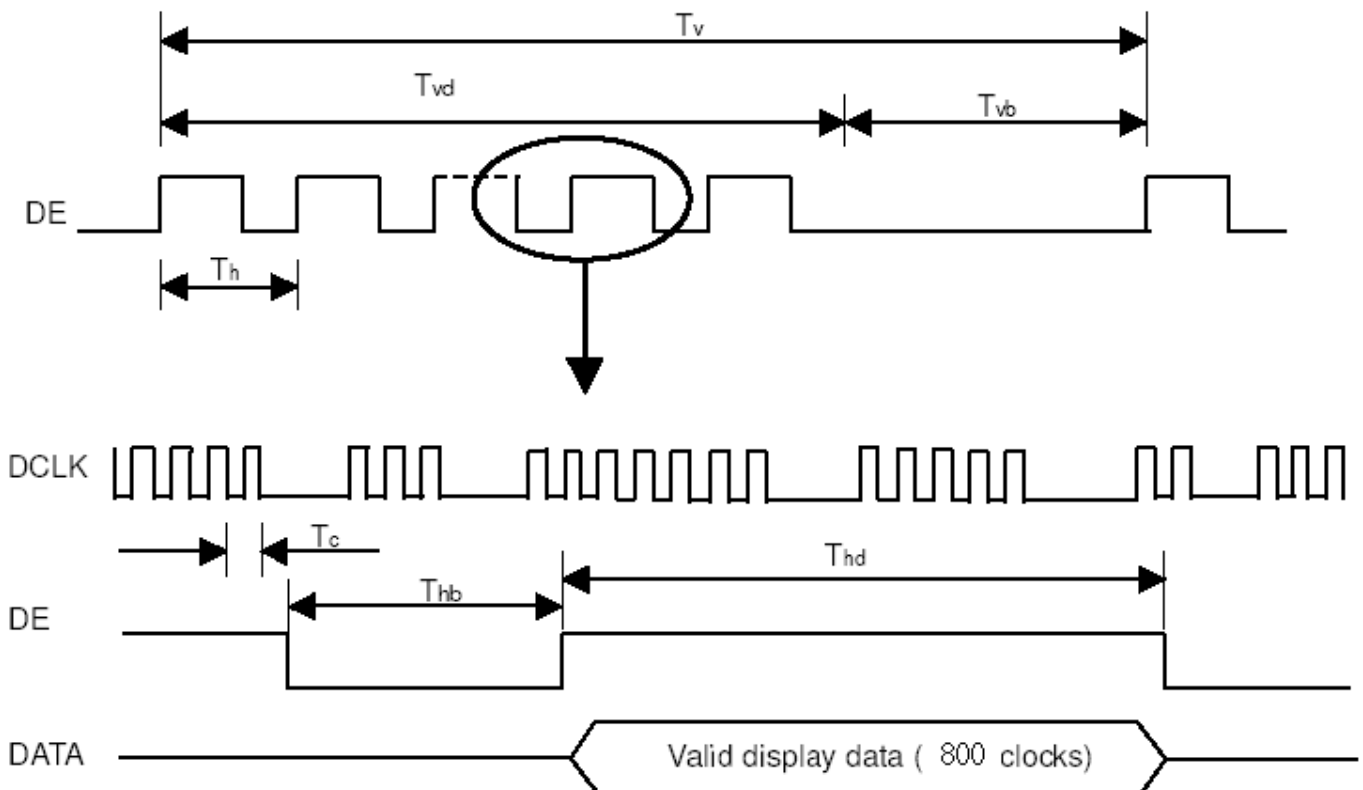



6.2 LVDS INPUT DATA FORMAT

FRC = "Low" or "NC" for 6 bits LVDS Input

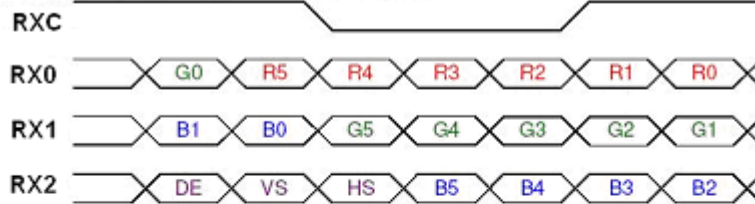

FRC = "High" for 8 bits LVDS Input

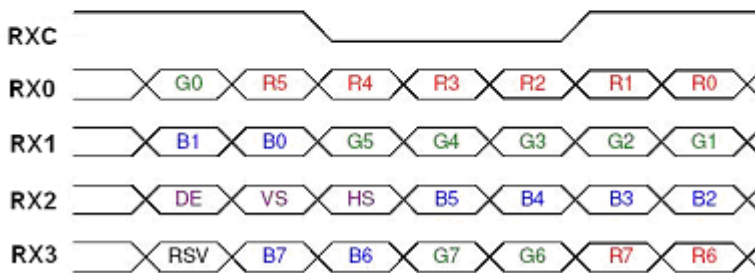

Note (1) R/G/B data 7: MSB, R/G/B data 0: LSB

Note (2) Please follow PSWG

Signal Name	Description	Remark
R7	Red Data 7 (MSB)	Red-pixel Data Each red pixel's brightness data consists of these 8 bits pixel data.
R6	Red Data 6	
R5	Red Data 5	
R4	Red Data 4	
R3	Red Data 3	
R2	Red Data 2	
R1	Red Data 1	
R0	Red Data 0 (LSB)	
G7	Green Data 7 (MSB)	Green-pixel Data Each green pixel's brightness data consists of these 8 bits pixel data.
G6	GreenData 6	
G5	GreenData 5	
G4	GreenData 4	
G3	GreenData 3	
G2	GreenData 2	
G1	GreenData 1	
G0	GreenData 0 (LSB)	
B7	Blue Data 7 (MSB)	Blue-pixel Data Each blue pixel's brightness data consists of these 8 bits pixel data.
B6	Blue Data 6	
B5	Blue Data 5	
B4	Blue Data 4	
B3	Blue Data 3	
B2	Blue Data 2	
B1	Blue Data 1	
B0	Blue Data 0 (LSB)	
RXCLKIN+ RXCLKIN-	LVDS Clock Input	
DE	Display Enable	
VS	Vertical Sync	
HS	Horizontal Sync	

Note (3) Output signals from any system shall be low or Hi-Z state when VCC is off.

### 6.3 POWER ON/OFF SEQUENCE

To prevent a latch-up or DC operation of LCD assembly, the power on/off sequence should be as the diagram below

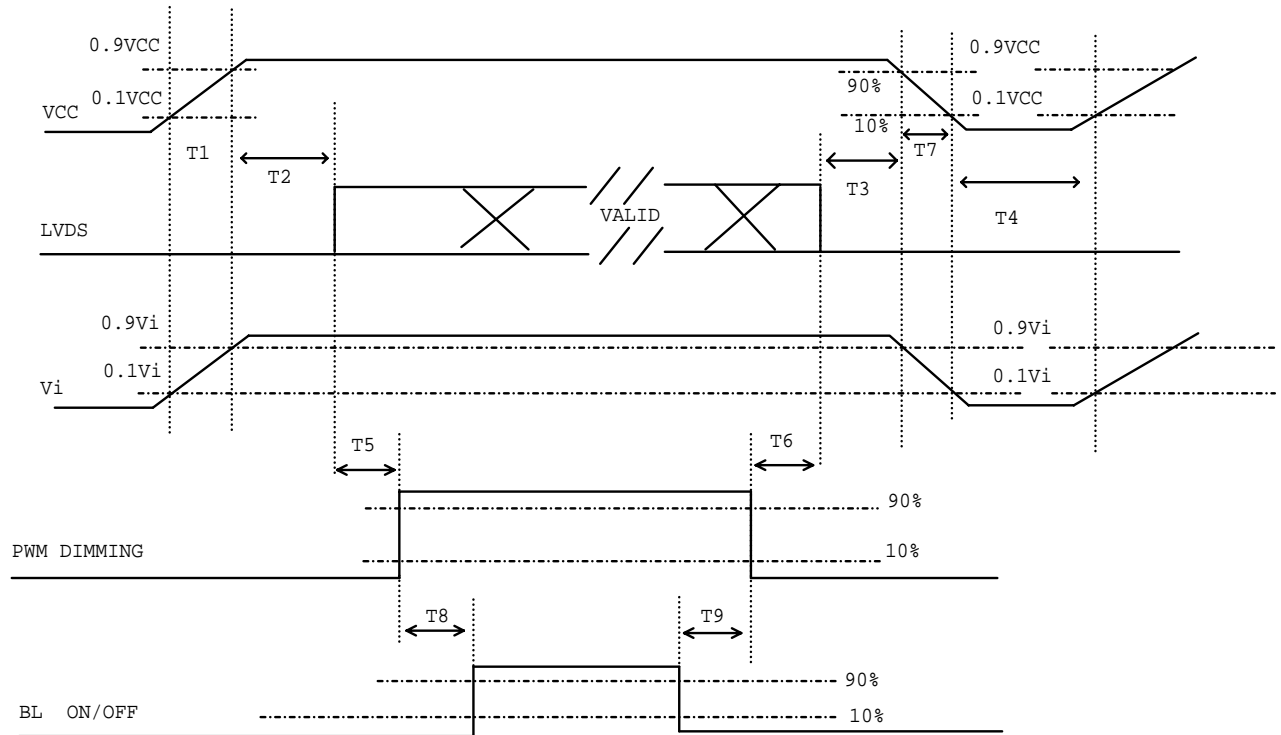

#### Power ON/OFF sequence

Note (1) Please avoid floating state of interface signal at invalid period.

Note (2) When the interface signal is invalid, be sure to pull down the power supply of LCD VCC to 0 V.

Note (3) The Backlight converter power must be turned on after the power supply for the logic and the interface signal is valid. The Backlight converter power must be turned off before the power supply for the logic and the interface signal is invalid.

Parameter	Value			Units
	Min	Typ	Max	
<b>T1</b>	<b>0.5</b>	-	<b>10</b>	<b>ms</b>
<b>T2</b>	<b>0</b>	-	<b>50</b>	<b>ms</b>
<b>T3</b>	<b>0</b>	-	<b>50</b>	<b>ms</b>
<b>T4</b>	<b>500</b>	-	-	<b>ms</b>
<b>T5</b>	<b>20</b>	-	-	<b>ms</b>
<b>T6</b>	<b>10</b>	-	-	<b>ms</b>
<b>T7</b>	<b>5</b>	-	<b>300</b>	<b>ms</b>
<b>T8</b>	<b>10</b>	-	-	<b>ms</b>
<b>T9</b>	<b>10</b>	-	-	<b>ms</b>

## 7. OPTICAL CHARACTERISTICS

### 7.1 TEST CONDITIONS

Item	Symbol	Value	Unit
Ambient Temperature	Ta	25±2	°C
Ambient Humidity	Ha	50±10	%RH
Supply Voltage	V <sub>CC</sub>	3.3	V
Input Signal	According to typical value in "3. ELECTRICAL CHARACTERISTICS"		
Current	I <sub>f</sub>	55±3	mA
Converter Duty		100	%

Note (1) I<sub>f</sub> means the forward current of each channel

### 7.2 OPTICAL SPECIFICATIONS

The relative measurement methods of optical characteristics are shown in 7.2. The following items should be measured under the test conditions described in 7.1 and stable environment shown in Note (6).

Item		Symbol	Condition	Min.	Typ.	Max.	Unit	Note						
Color Chromaticity	Red	R <sub>x</sub>	$\theta_x=0^\circ, \theta_y=0^\circ$ Viewing Normal Angle	Typ - 0.03	0.645	Typ + 0.03		(1), (6)						
		R <sub>y</sub>			0.341									
	Green	G <sub>x</sub>			0.312									
		G <sub>y</sub>			0.625									
	Blue	B <sub>x</sub>			0.153									
		B <sub>y</sub>			0.053									
	White	W <sub>x</sub>			0.313									
		W <sub>y</sub>			0.329									
	Center Luminance of White				L <sub>C</sub>					400	500		cd/m <sup>2</sup>	(4), (6)
	Contrast Ratio				CR					500	600		-	(2), (6)
Response Time		T <sub>R</sub>			5	10	Ms	(3)						
		T <sub>F</sub>			11	16	Ms							
White Variation		δW			1.25	1.4	-	(5), (6)						
Viewing Angle	Horizontal	θ <sub>x+</sub>	CR 10		60	70		Deg.	(1), (6)					
		θ <sub>x-</sub>			60	70								
	Vertical	θ <sub>y+</sub>			50	60								
		θ <sub>y-</sub>			50	60								

Note (1) Definition of Viewing Angle ( $\theta_x, \theta_y$ ):

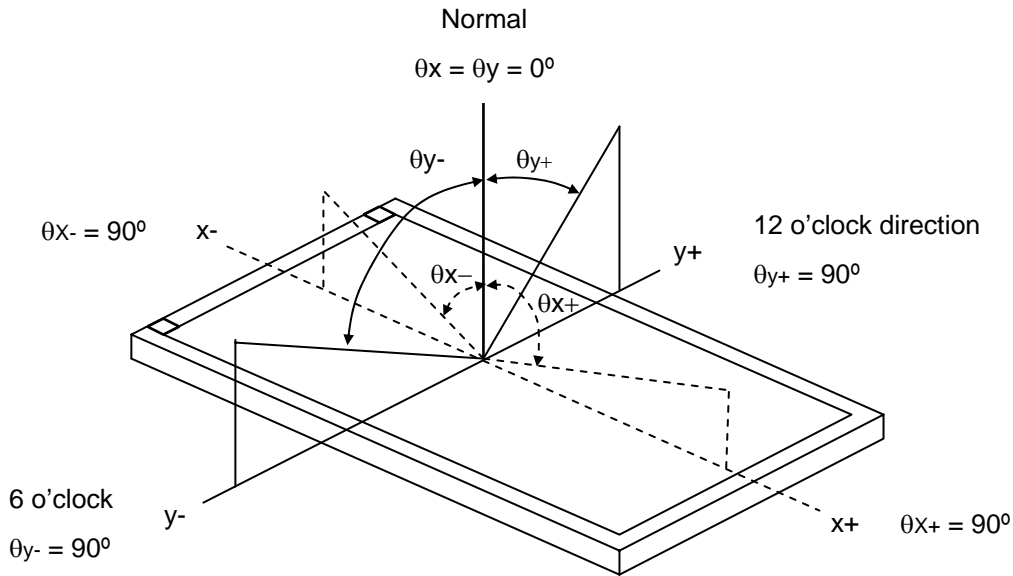

Note (2) Definition of Contrast Ratio (CR):

The contrast ratio can be calculated by the following expression.

$$\text{Contrast Ratio (CR)} = L_{63} / L_0$$

L63: Luminance of gray level 63

L 0: Luminance of gray level 0

$$\text{CR} = \text{CR} (5)$$

CR (X) is corresponding to the Contrast Ratio of the point X at Figure in Note (5).

Note (3) Definition of Response Time ( $T_R, T_F$ ) and measurement method:

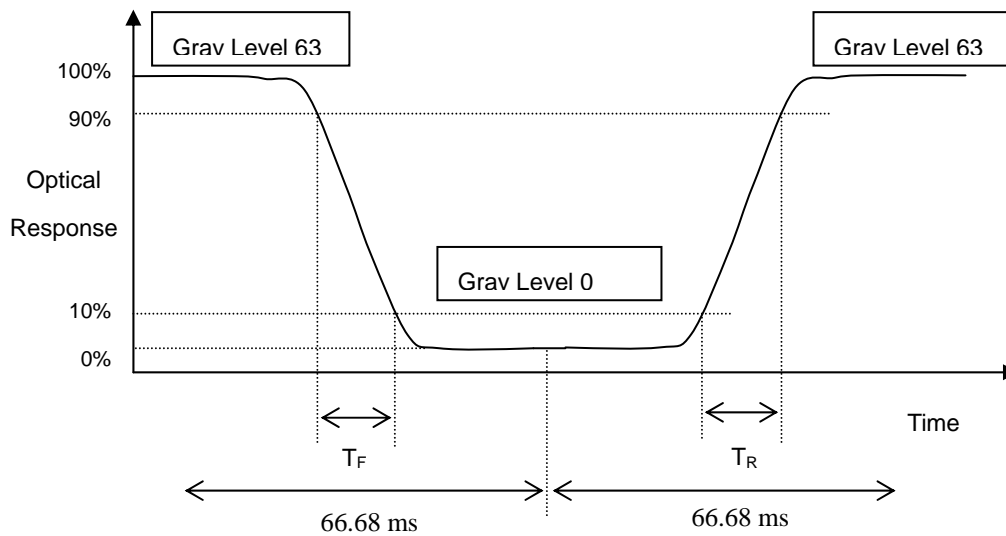

Note (4) Definition of Luminance of White ( $L_C$ ):

Measure the luminance of gray level 63 at center point

$$L_C = L(5)$$

$L(x)$  is corresponding to the luminance of the point X at Figure in Note (5).

Note (5) Definition of White Variation ( $\delta W$ ):

Measure the luminance of gray level 63 at 5 points

$$\delta W = \text{Maximum} [L(1), L(2), L(3), L(4), L(5)] / \text{Minimum} [L(1), L(2), L(3), L(4), L(5)]$$

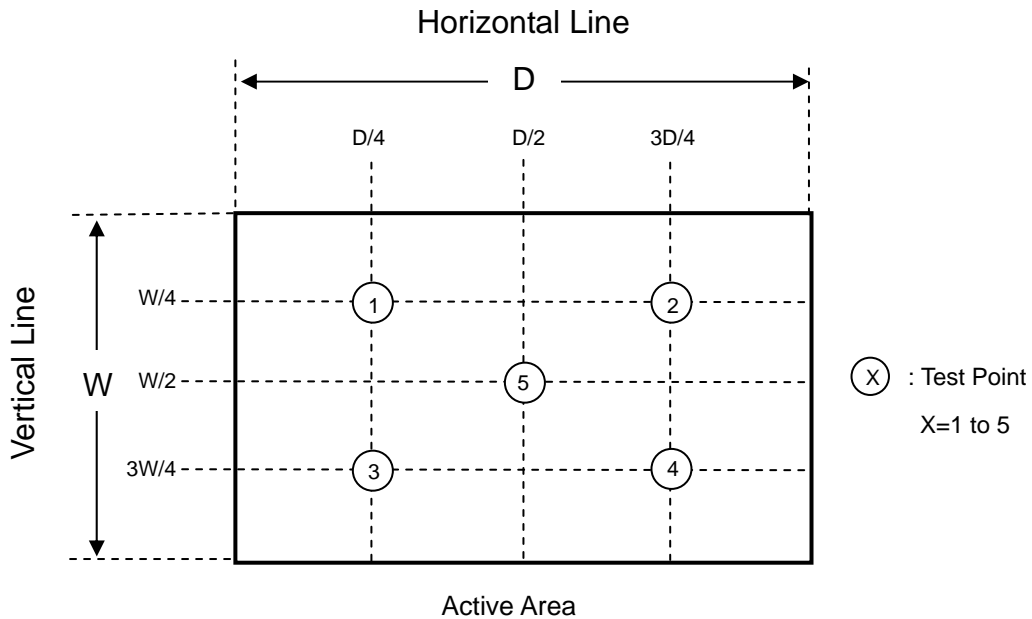

Note (6) Measurement Setup:

The LCD module should be stabilized at given temperature for 20 minutes to avoid abrupt temperature change during measuring. In order to stabilize the luminance, the measurement should be executed after lighting Backlight for 20 minutes in a windless room.

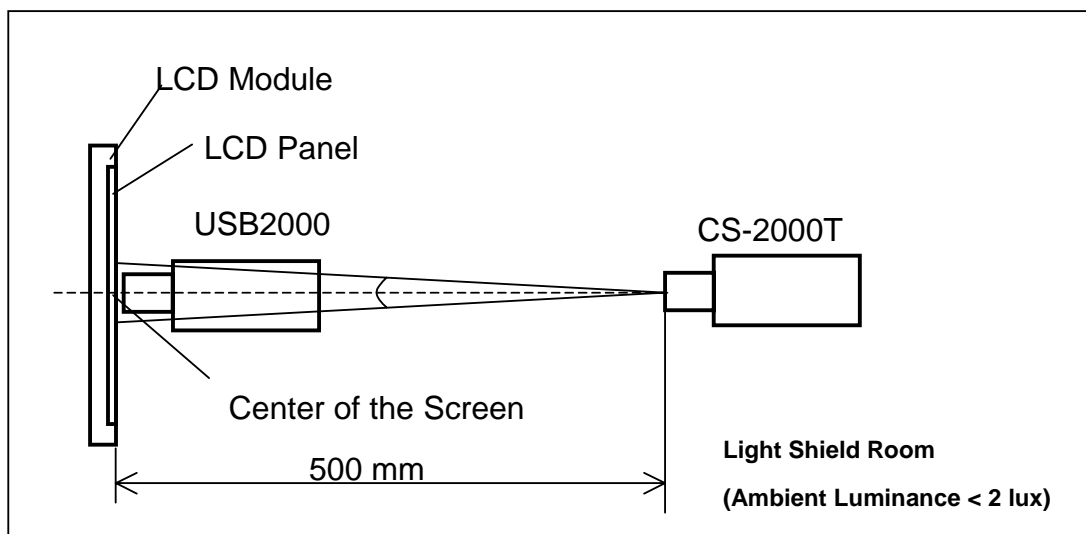

8. RELIABILITY TEST

8.1 RELIABILITY TEST CONDITION

No.	Test Item	Test Condition	Note
1	High Temperature Storage	95 , 240 hours	(1) (2)
2	Low Temperature Storage	-40 , 240 hours	
3	Thermal Shock Storage	{{(-40 , 0.5 hour) (85 , 0.5 hour)}, 100 cycles	
4	High Temperature Operating	85 , 240 hours	
5	Low Temperature Operating	-30 , 240 hours	
6	High Temperature & High Humidity Operating	60 , 90% RH, 240hours	
7	Shock (Non-Operating)	100G, 6ms, half sine wave, 3 times for ± X, ± Y, ± Z.	(3)
8	Vibration (Non-Operating)	3G, 10 ~ 200 Hz, 10min/cycle, 3 cycles each X, Y, Z	(3)

Note (1) There should be no condensation on the surface of panel during test.

Note (2) The temperature of panel display surface area should be 95 Max.

Note (3) At testing Vibration and Shock, the fixture in holding the module has to be hard and rigid enough so that the module would not be twisted or bent by the fixture.

Note (4) In the standard conditions, there is no function failure issue occurred. All the cosmetic specification is judged before the reliability test.

9. PACKAGING

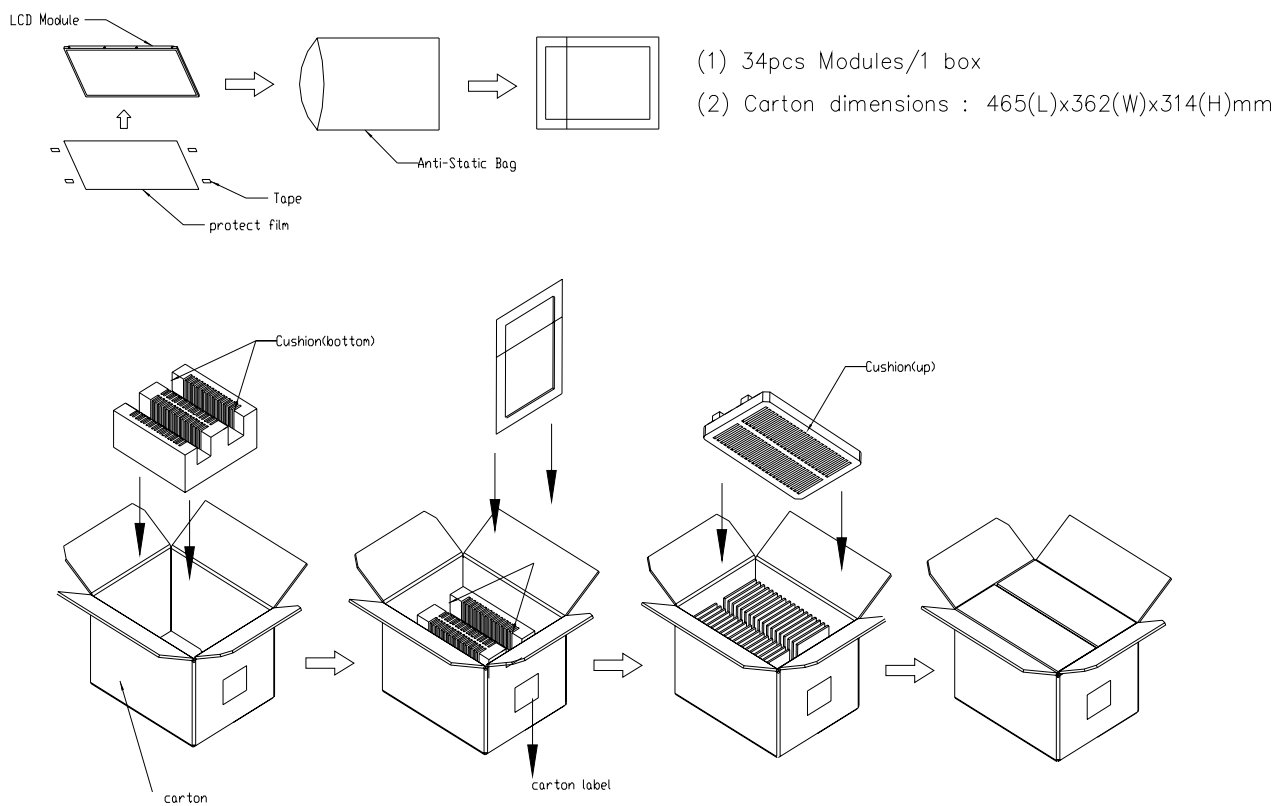

Sea / Land Transportation (40ft Container)

Air Transportation

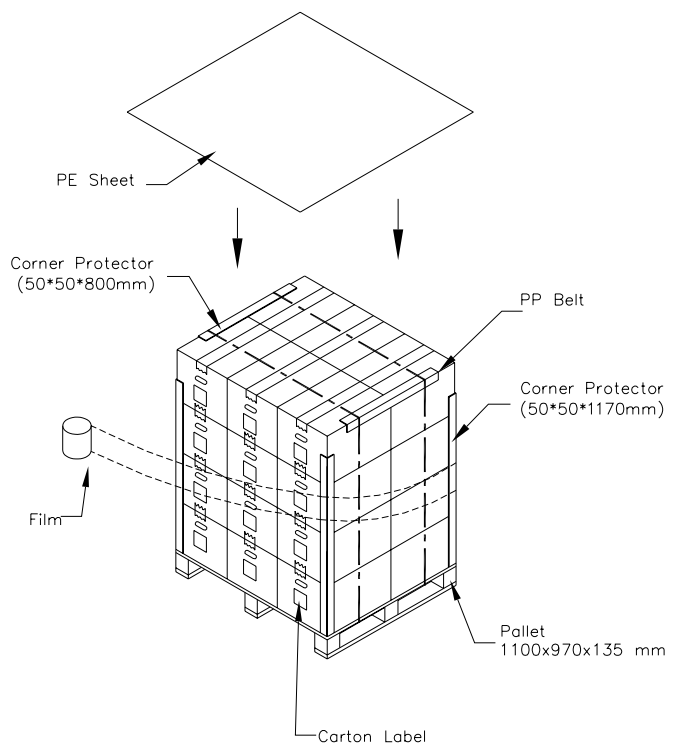
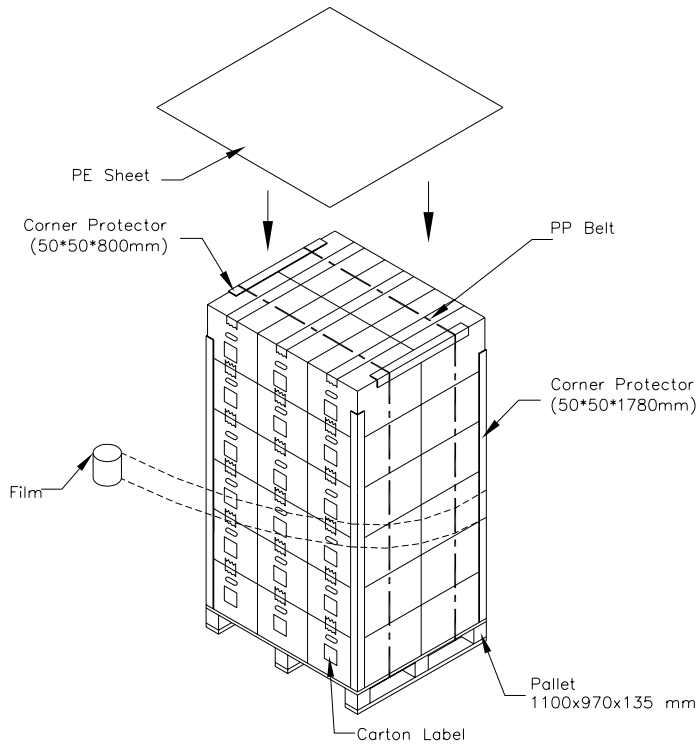



10. DEFINITION OF LABELS

10.1 CMO MODULE LABEL

The barcode nameplate is pasted on each module as illustration, and its definitions are as following explanation.



- (a) Model Name: G070Y2 -L01
- (b) Revision: Rev. XX, for example: A1, ..., C1, C2 ...etc.
- (c) Serial ID: XXXXXXYMDXNNNN

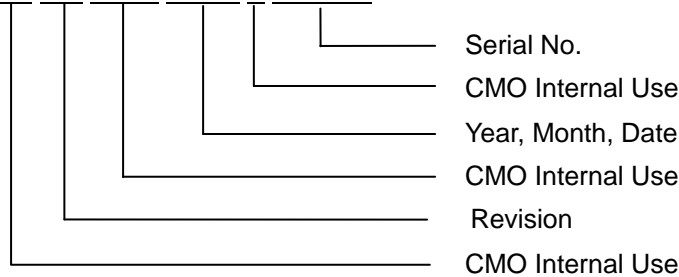

Serial ID includes the information as below:

- (a) Manufactured Date: Year: 1~9, for 2001~2009  
 Month: 1~9, A~C, for Jan. ~ Dec.  
 Day: 1~9, A~Y, for 1<sup>st</sup> to 31<sup>st</sup>, exclude I, O and U
- (b) Revision Code: cover all the change  
 Serial No.: Manufacturing sequence of product

## 11. PRECAUTIONS

### 11.1 ASSEMBLY AND HANDLING PRECAUTIONS

- (1) Do not apply rough force such as bending or twisting to the module during assembly.
- (2) To assemble or install module into user's system can be only in clean working areas. The dust and oil may cause electrical short or worsen the polarizer.
- (3) It's not permitted to have pressure or impulse on the module because the LCD panel and Backlight will be damaged.
- (4) Always follow the correct power sequence when LCD module is connecting and operating. This can prevent damage to the CMOS LSI chips during latch-up.
- (5) Do not pull the I/F connector in or out while the module is operating.
- (6) Do not disassemble the module.
- (7) Use a soft dry cloth without chemicals for cleaning, because the surface of polarizer is very soft and easily scratched.
- (8) It is dangerous that moisture come into or contacted the LCD module, because moisture may damage LCD module when it is operating.
- (9) High temperature or humidity may reduce the performance of module. Please store LCD module within the specified storage conditions.
- (10) When ambient temperature is lower than 10°C may reduce the display quality. For example, the response time will become slowly, and the starting voltage of CCFL will be higher than room temperature.
- (11) Do not keep same pattern in a long period of time. It may cause image sticking on LCD

### 11.2 SAFETY PRECAUTIONS

- (1) Do not disassemble the module or insert anything into the Backlight unit to prevent electrical shock.
- (2) If the liquid crystal material leaks from the panel, it should be kept away from the eyes or mouth. In case of contact with hands, skin or clothes, it has to be washed away thoroughly with soap.
- (3) After the module's end of life, it is not harmful in case of normal operation and storage.

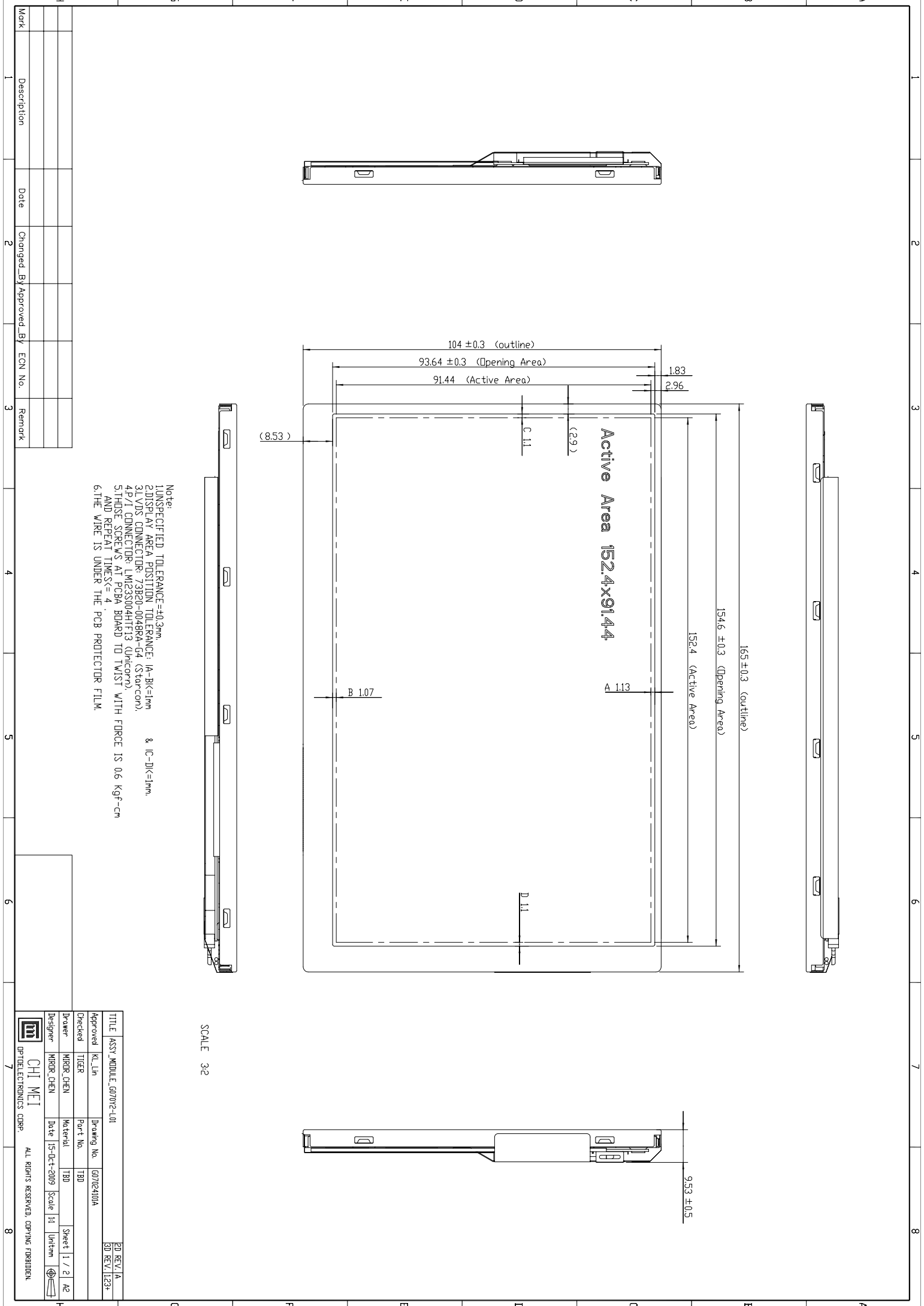

SCALE 3:2

Work	Description	Date	Changed By	Approved By	ECN No.	Remark
1						
2	Changed					
3						
4						
5						
6						
7						
8						

TITLE	ASSY_MODULE_60702-1.01		2D REV 1 A
Approved	KL Lin	Drawing No.	60702A101A
Checked	TIGER	Part No.	TBD
Designer	MIROR CHEN	Date	15-Dec-2009
Drawer	MIROR CHEN	Scale	1:1
Material	TBD	Unit	mm
		Sheet	1 / 2
		AR	

CHI MEI  
OPTOELECTRONICS CORP.  
ALL RIGHTS RESERVED. COPYING PROHIBITED.

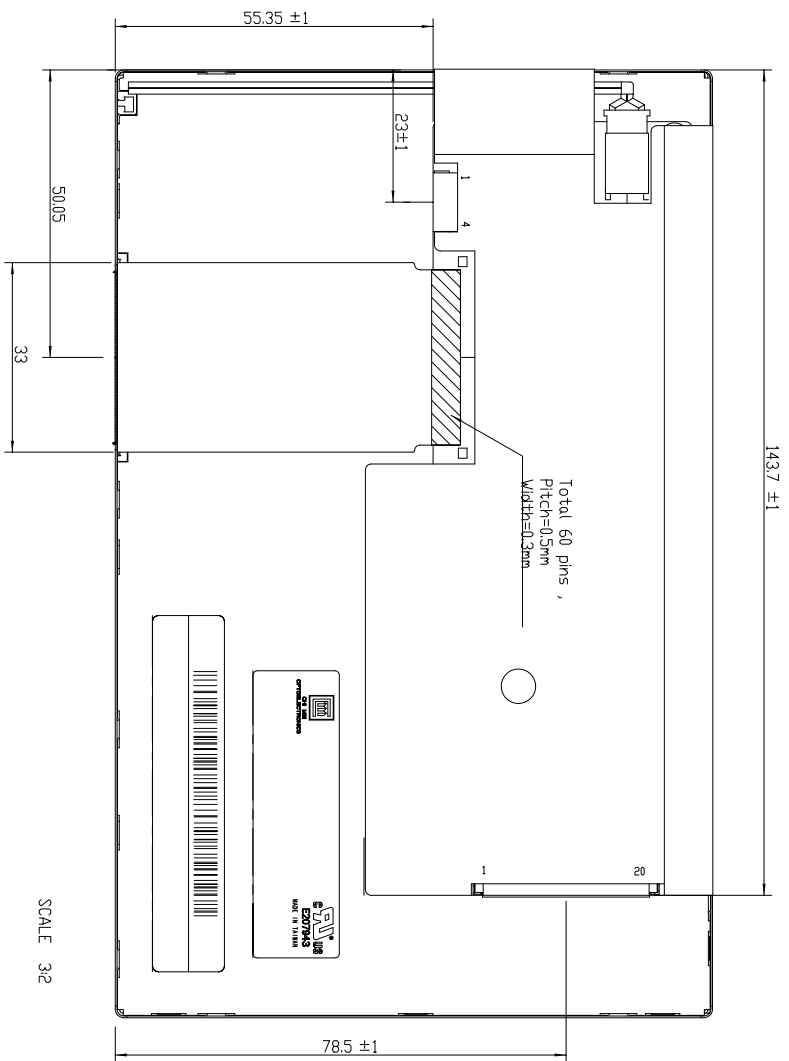

SCALE 3:2

- Note:
1. UNSPECIFIED TOLERANCE=±0.3mm.
  2. DISPLAY AREA POSITION TOLERANCE: IA-BK<=1mm & C-DK<=1mm.
  3. LENS CONNECTOR: 73820-0048RA-04 (Starconn).
  4. P/T CONNECTOR: LM23504HTF13 (uhicorrn).
  5. THOSE SCREWS AT PCB BOARD TO TWIST WITH FORCE IS 0.6 KgF-cm AND REPEAT TIMES<= 4.
  6. THE WIRE IS UNDER THE PCB PROTECTOR FILM.

Work	Description	Date	Changed By	Approved By	ECN No.	Remark
1						
2	Changed					
3						
4						
5						
6						
7						
8						

TITLE	ASSY_MODULE_6070V2-1.01		2D REV1/A	
Approved	KL Lin	Drawing No.	6070V2A101A	3D REV1/E23*
Checked	TIGER	Part No.	TBD	
Designer	MIROR CHEN	Date	15-Dec-2009	Scale 1:1
Drawer	MIROR CHEN	Material	TBD	Sheet 2 / 2
Design	MIROR CHEN	Scale	1:1	Unit:mm

CHI MEI  
OPTOELECTRONICS CORP.

ALL RIGHTS RESERVED. COPYING PROHIBITED.