



FTF 2016
TECHNOLOGY FORUM

NXP USB TYPE-C SOLUTION

FTF-DES-N1909

JAY LI
INTERNATIONAL PRODUCT MARKETING MANAGER
FTF-DES-N1909
MAY 17, 2016

PUBLIC USE



AGENDA

- USB Type-C Standard
- Introduction to USB Type-C Standard
- Eco-system, Market View, Applications
- System Solution for USB Type-C Connector
- Competitive Position
- B Type-C Standard



NXP Secure Interfaces & Power Solutions

Signal Management	Smart Power	Bus Enablers & Peripherals
<p>SIGNAL SWITCHES</p> <ul style="list-style-type: none"> • USB Type-C • Thunderbolt • PCIe • SATA, SAS • Memory Interfaces • USB • DisplayPort (DP) • HDMI • MHL • MIPI • CSI/DSI • VGA • Audio <p>GENERAL PURPOSE SWITCHES</p> <ul style="list-style-type: none"> • Analog <p>SIGNAL INTEGRITY</p> <ul style="list-style-type: none"> • HDMI/DVI Level Shifters • USB 3.0 Redrivers <p>ADAPTERS, BRIDGES & UARTs</p>	<p>DISTRIBUTION & PROTECTION</p> <ul style="list-style-type: none"> • Load Switches • Surge Protection/e-Fuses • USB Power Switches • USB PD / Type-C <p>CHARGING</p> <ul style="list-style-type: none"> • Wireless Charging • Rapid Battery Charging <ul style="list-style-type: none"> • POWER Management • Battery Management with PMIC • AC-to-DC Solutions <p>POWERLINE COMMUNICATION</p> <ul style="list-style-type: none"> • Modems <p>POWER Conversion</p> <ul style="list-style-type: none"> • DC-DC, Buck/Boost 	<p>I²C-bus ENABLERS</p> <ul style="list-style-type: none"> • Bus Buffers • Level Translators • Muxes & Switches • Bus Controllers <ul style="list-style-type: none"> • Real Time Clocks • LCD Display Drivers <p>I²C-bus PERIPHERALS</p> <ul style="list-style-type: none"> • General Purpose I/Os (Expanders) • Temperature Sensors • LED Controllers • Stepper Motor Controller • Real Time Clocks • LCD Display Drivers • Capacitive Touch Switches & Proximity Sensors • EEPROMs & DIP Switches • Data Converters <p>OTHER BUSES(SPI, ETC.)</p> <ul style="list-style-type: none"> • Bus Buffers • Level Translators • General Purpose I/Os (Expanders)

Capabilities of USB Type-C Interface

USB Type-C Standard

- Allows USB 2.0, USB 3.1 and up to 15W (5V and 1.5A or 3A)
- USB 3.1 Gen1 (5 Gbps), Gen2 (10 Gbps)

USB Power Delivery (PD) Standard

- Adds ability to do scalable power charging (up to 100W)

USB Type-C Alternate Mode Standard

- Adds ability to support DisplayPort Video over USB Type-C

USB PD and Alternate Mode implementation requires intelligence in the system. Hence, Alternate Mode spec is tied to PD. USB-PD implementation is required to support Alternate Mode.

USB Type – C Interface Benefits

Size

- Smaller connector designed to fit all form factors

Ease of Use

- User friendly
- Independent of plug orientation and cable direction

Future Scalability

- Designed to support future upgrades in the spec – higher speeds

Extends USB Family

- Legacy USB devices supported. C to A cable.

Last Connector

- Enables one connector platform
- Supports power, video and data over single connector



What is USB-Power Delivery (PD)?

- USB-PD specification extends USB capability to 100W
- Various power configurations possible – fixed, programmable, battery, fast charging
- Possible to change the power flow (power role swap)
- Source power profiles

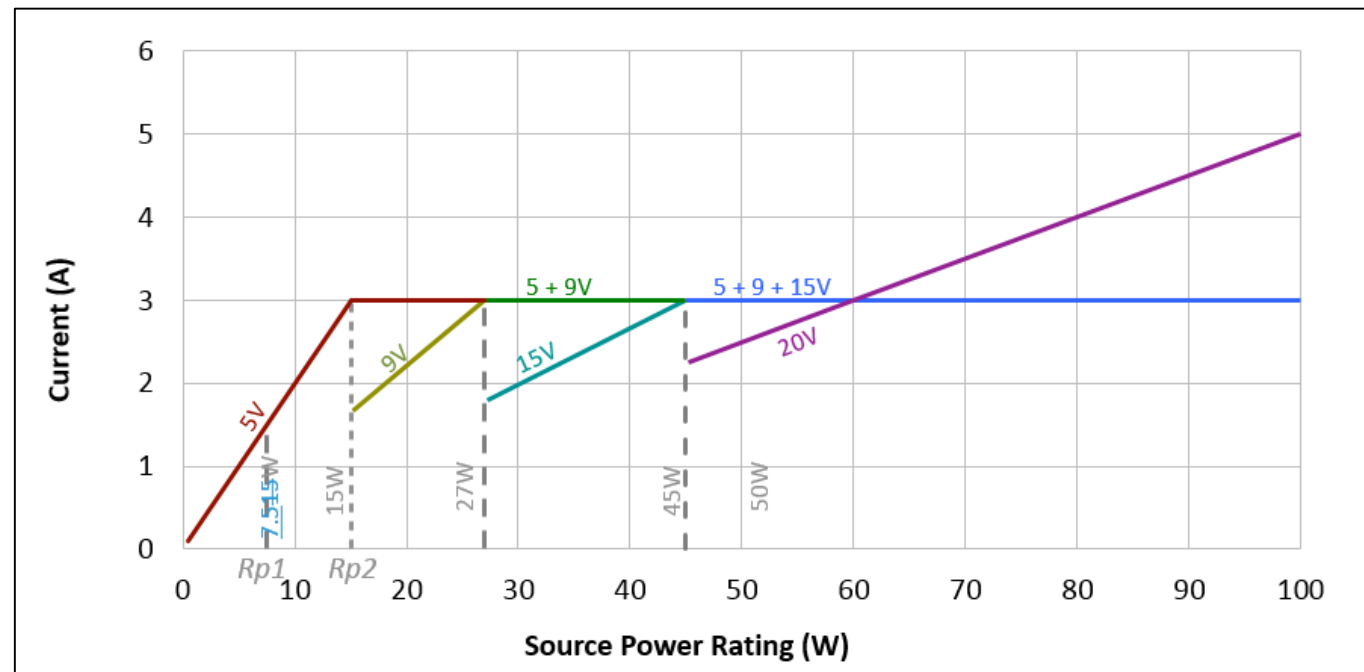

USB Type C Ports

Port Type	Description
DFP – Downstream Facing Port	“USB host” & initial Vbus/VCONN source, Typical Standard-A host
UFP – Upstream Facing Port	“USB device” & initial Vbus sink, Typical Standard-B device
DRP – Dual Role Port	A port that may operate as a DFP or UFP

What is Alternate Mode Support?

- Alternate Mode support allows signals other than USB to pass through the Type-C connector.
- Under Alternate mode, a Type-C DRP can check the capability on the other end and send DisplayPort data over Type-C.
- Up to 4-lanes of DP signals can be sent through Type-C interface.
- This way video connectors other than DisplayPort (like VGA, HDMI) can be supported through Type – C protocol converters

USB Type-C Connector – Pinout and Alignment



Receptacle (Front View)

A1	A2	A3	A4	A5	A6	A7	A8	A9	A10	A11	A12
GND	TX1+	TX1-	VBUS	CC1	D+	D-	SBU1	VBUS	RX2-	RX2+	GND
GND	RX1+	RX1-	VBUS	SBU2	D-	D+	CC2	VBUS	TX2-	TX2+	GND
B12	B11	B10	B9	B8	B7	B6	B5	B4	B3	B2	B1
USB3.0				USB2.0				USB3.0			



Normal Plug

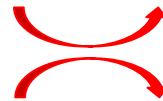

Reverse Plug



A12	A11	A10	A9	A8	A7	A6	A5	A4	A3	A2	A1
GND	RX2+	RX2-	VBUS	SBU1	D-	D+	CC	VBUS	TX1-	TX1+	GND
GND	TX2+	TX2-	VBUS	VCONN			SBU2	VBUS	RX1-	RX1+	GND
B1	B2	B3	B4	B5	B6	B7	B8	B9	B10	B11	B12

USB Type-C Receptacle Pins

Pins Defined for System or Device Receptacle

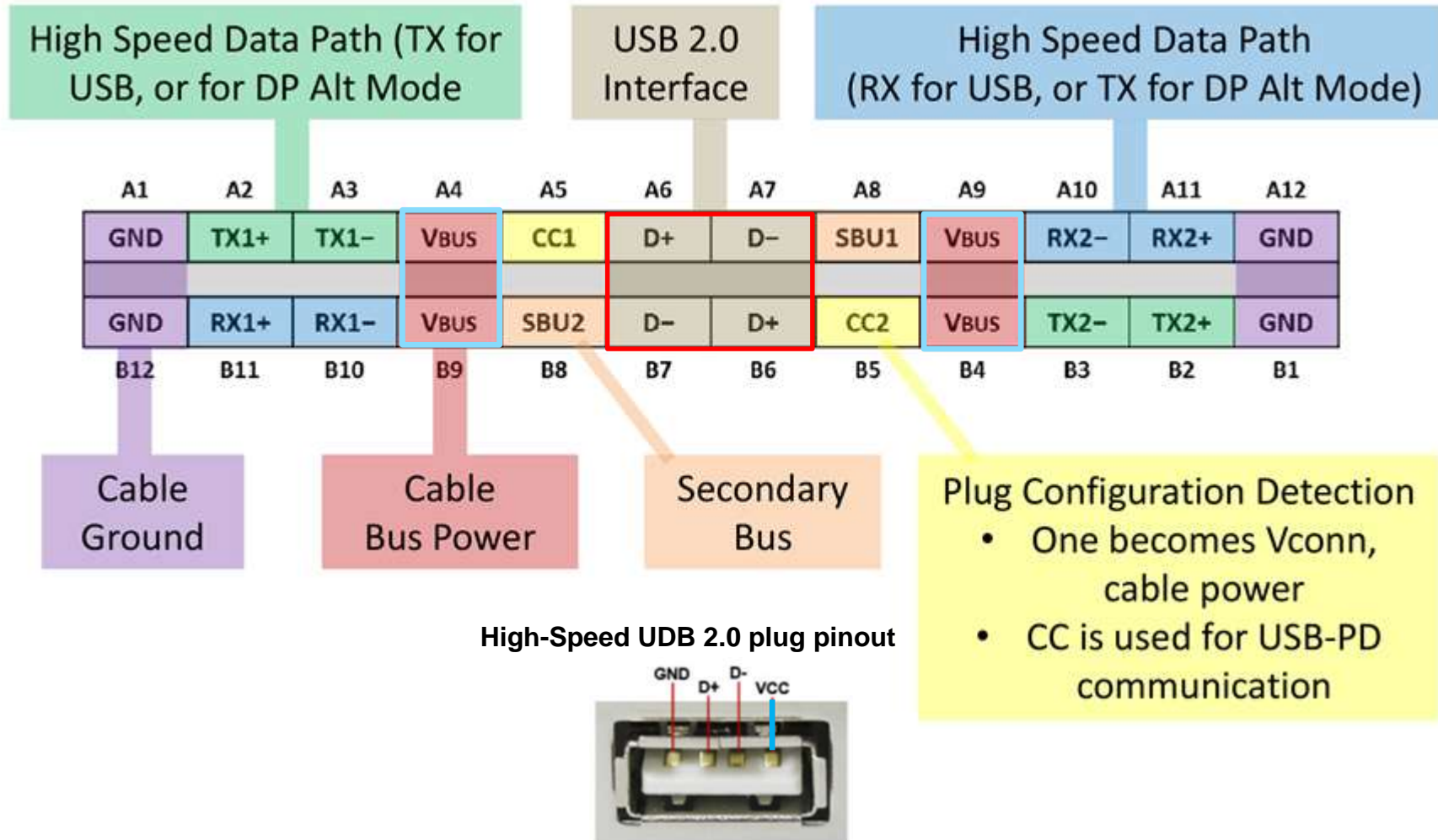

Plug Configuration Detection

- One becomes Vconn, cable power
- CC is used for USB-PD communication

USB Type C Spec – Power

Priority order for power

- USB PD
- USB Type-C
- USB BC1.2
- USB 2.0, USB3.1

Type	Voltage	Current
USB 2.0	5V	500mA
USB 3.0/USB 3.1	5V	900 mA
USB BC1.2	5V	1.5A
USB Type-C (without PD)	5V	1.5A, 3A
USB Type-C PD	Up to 20V	Up to 3A (Cable) Up to 5A (Elec. Marked Cable)

USB Type-C Configuration Channel

- CC pins and functionality
 - Attach/Detach detection
 - Determination Plug orientation
 - Initial Port role determination
 - USB PD Type C Communication (For PD)
 - Modification of initial port roles
 - Negotiation of USB PD power contracts
 - Management of Functional Extensions (For PD)
 - Structured Vendor Defined Messages (VDM)

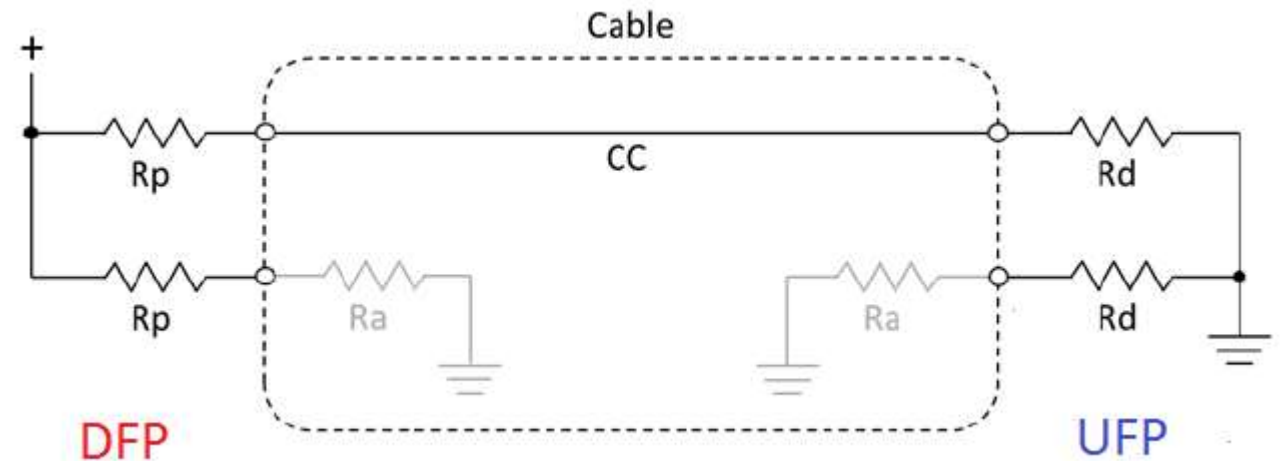

ECOSYSTEM & MARKET VIEW

Ecosystem Illustration

NXP offers USB Type-C solutions in

- Systems
- Cable and dongle adaptors
- AC/DC power adaptors

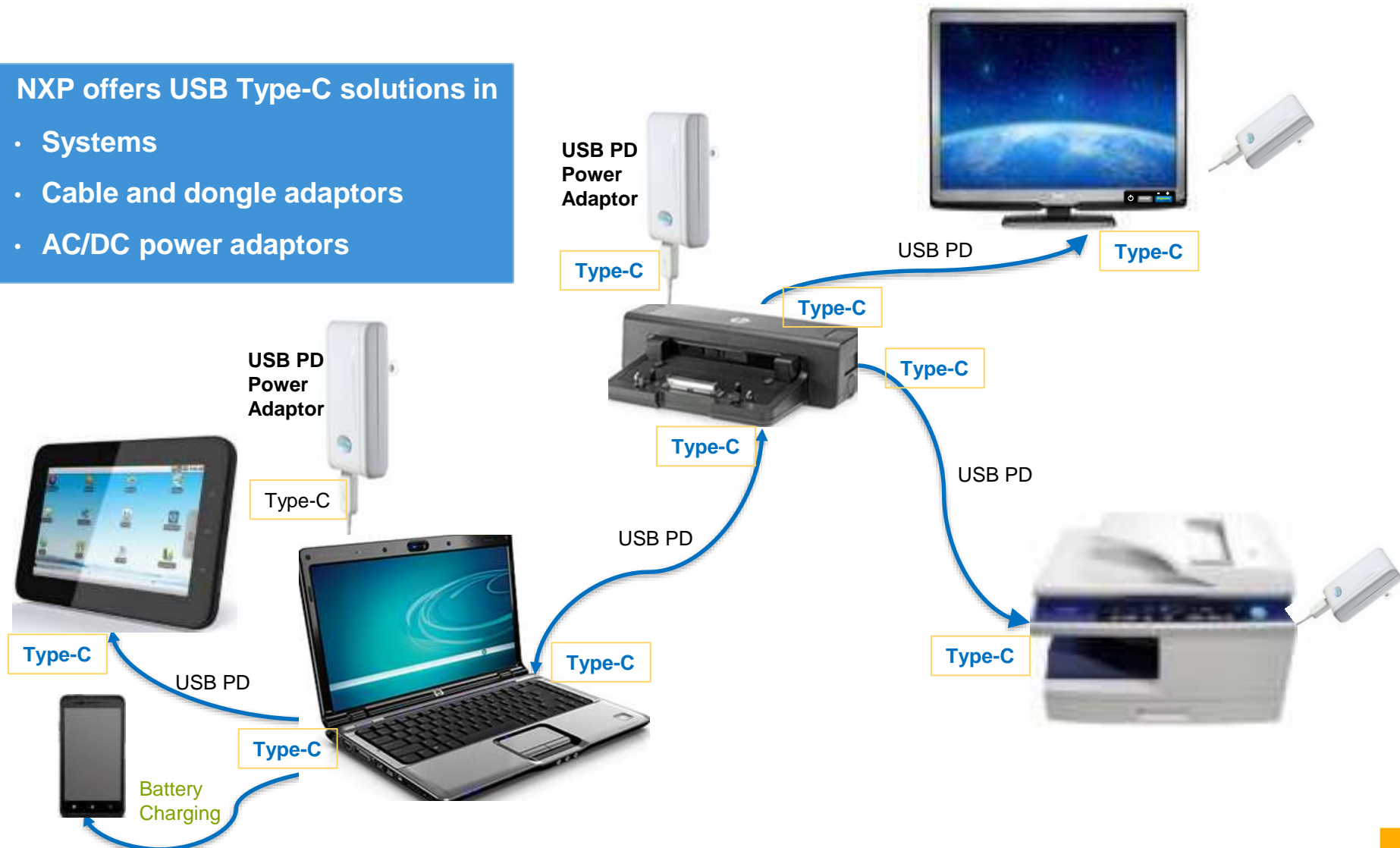

Ecosystem Illustration (I)

NXP offers USB Type-C solutions in

- Systems
- Cable and dongle adaptors
- AC/DC power adaptors

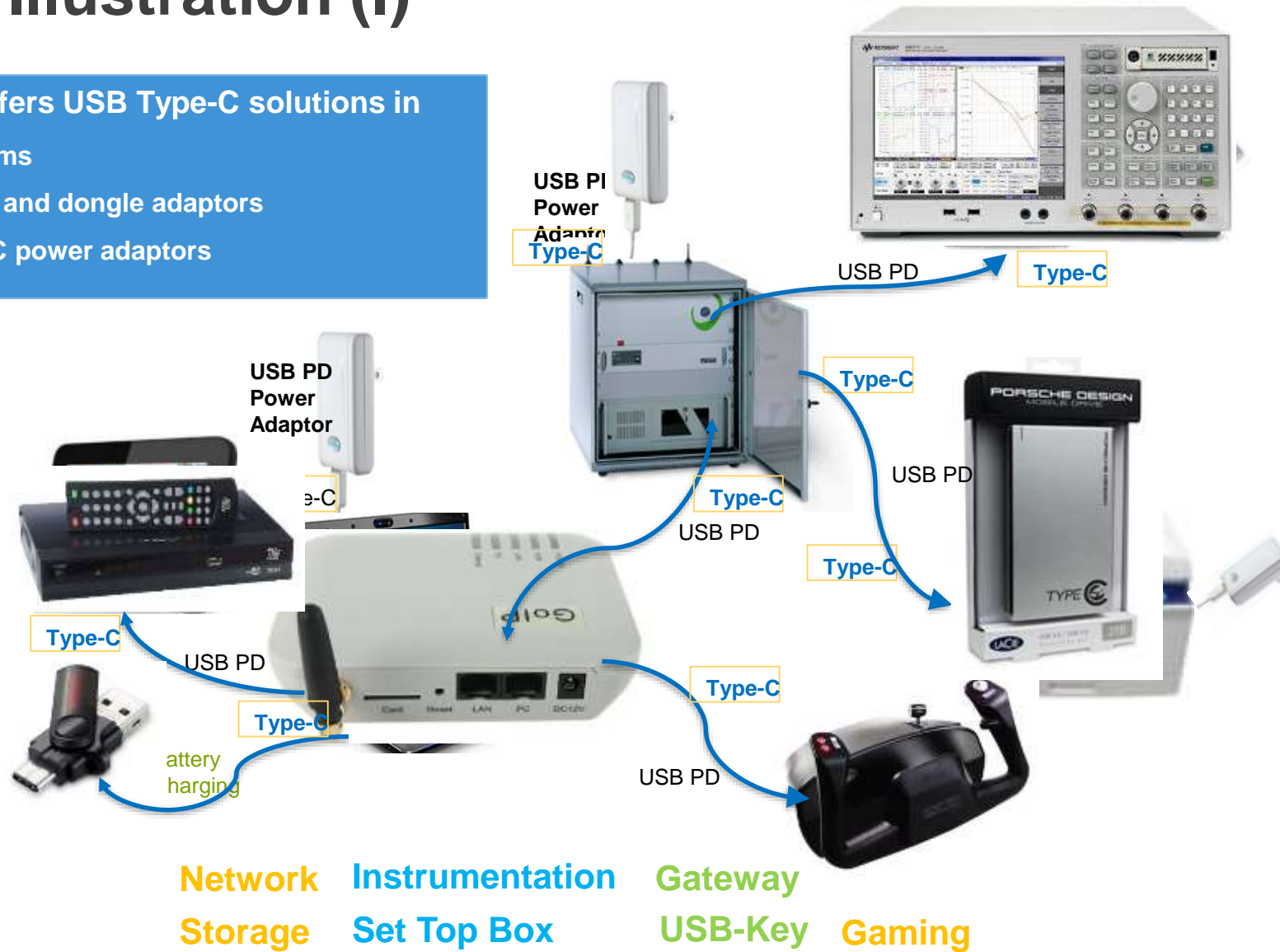

Network Storage **Instrumentation Set Top Box** **Gateway USB-Key** **Gaming**

Devices Available in Market Today



Target Applications

- Computing Accessories
 - Dongles
 - Docks
- Consumer Devices (Phones, Tablets, etc.)
- Industrial and Medical Devices
- Any device with a USB Port!

SYSTEM SOLUTION FOR USB TYPE-C CONNECTOR

System Solution for USB Type-C Connector with PD and Alternate Mode Support

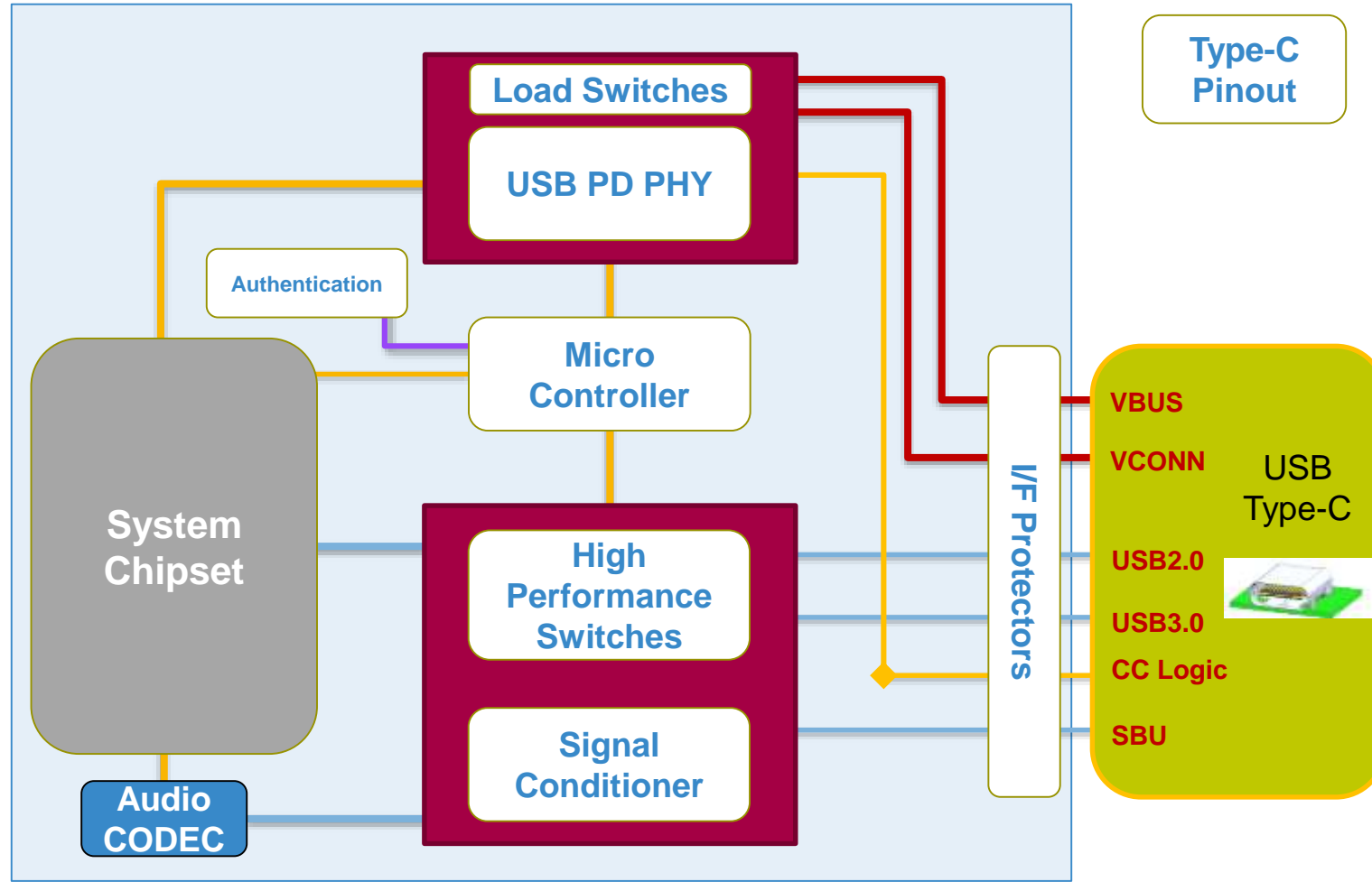

System Solution for USB Type-C (15W) with USB 3.1 Support

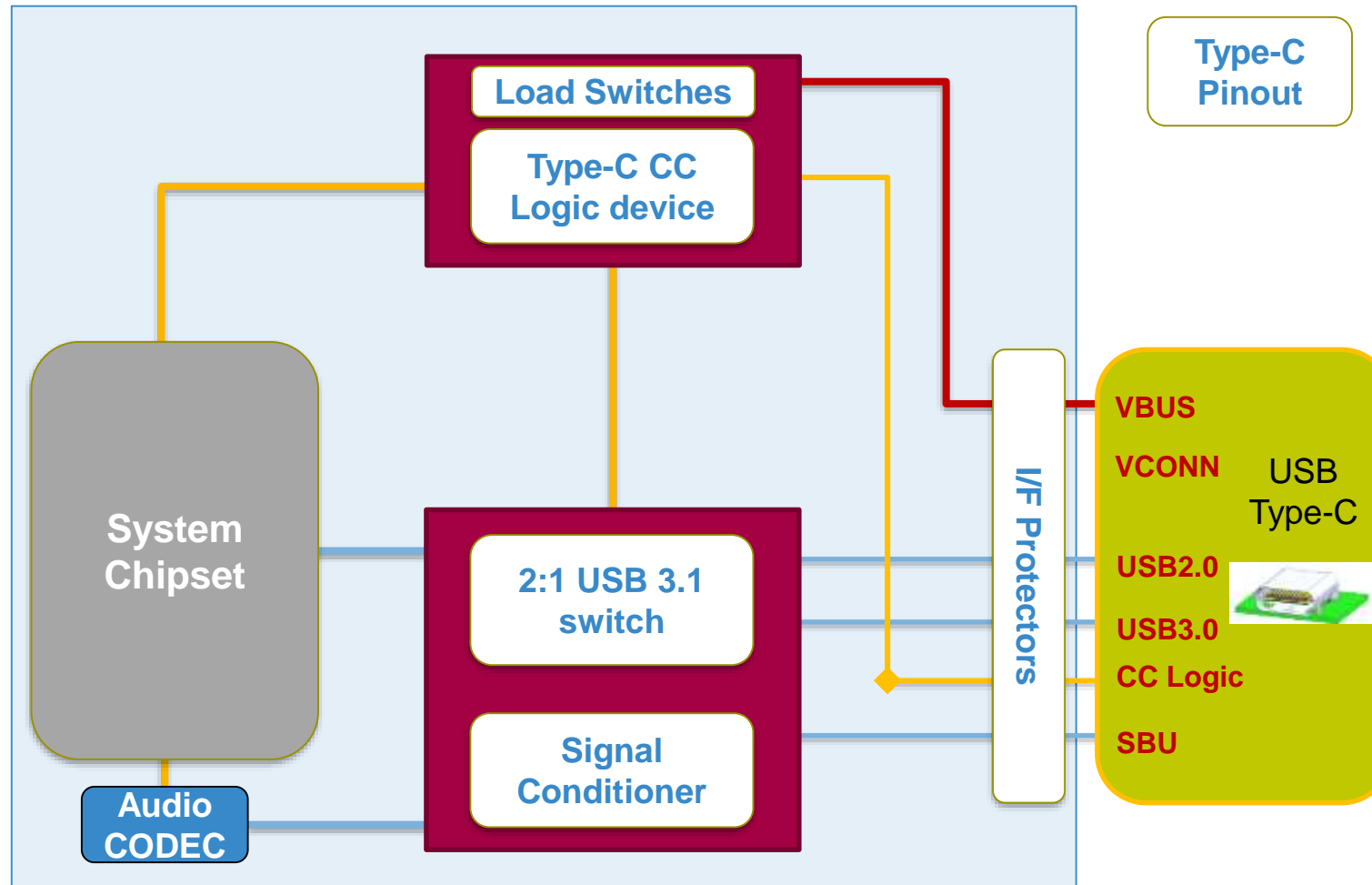

System Solution for USB Type-C (15W) with USB 2.0 Support

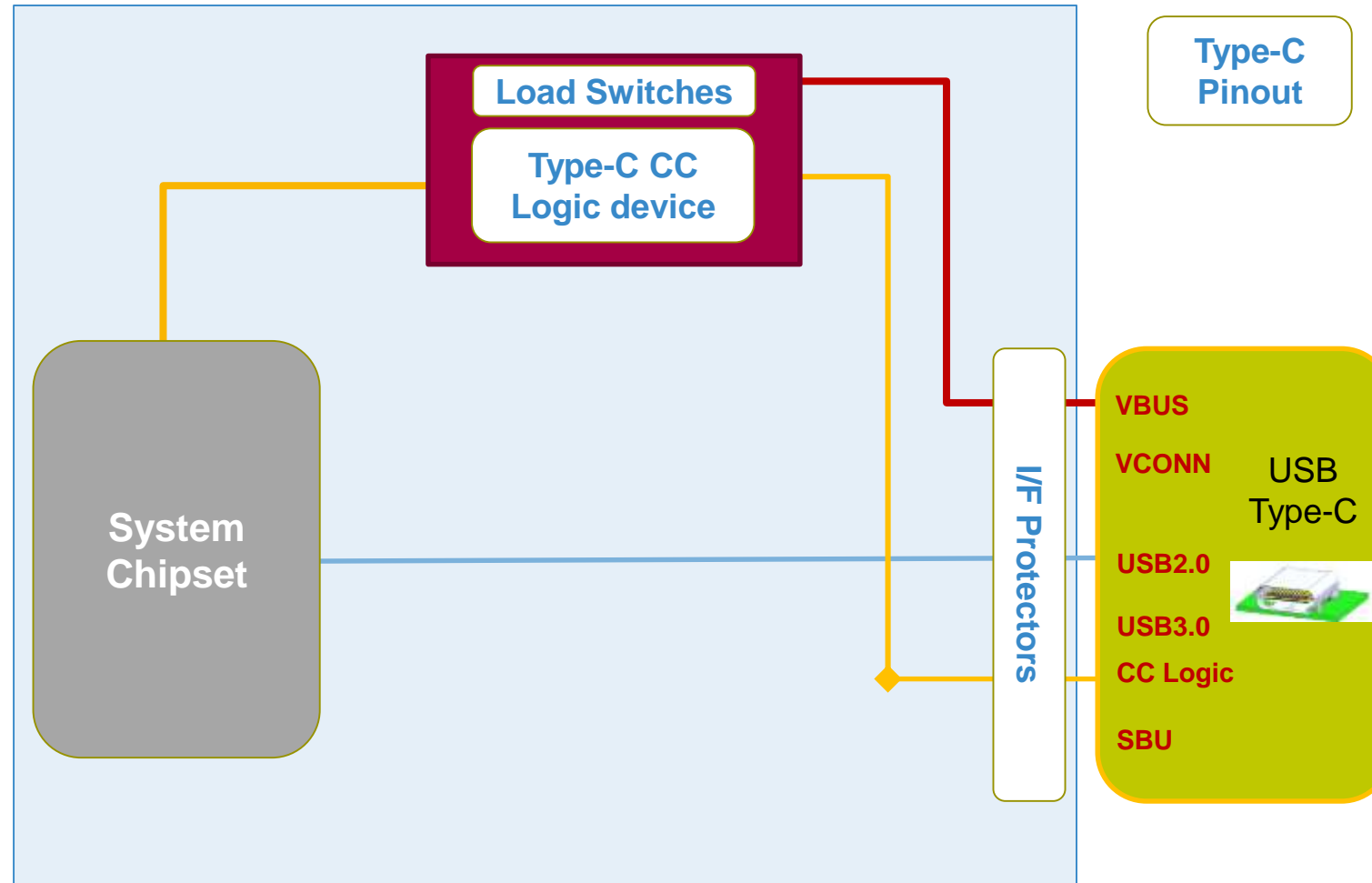

USB TYPE-C SWITCHES

What is a Signal Switch and Why NXP?

- **Why is it Needed?**

- For type-C connector to support “Alternate Mode” or “plug flippable” functions, either multiplex or de-multiplex switch function will be used, or sometimes these functions are combined together to become a cross-point switch.

- **What is a Signal Switch?**

- Switch provides signal multiplex or de-multiplex function in order to redirect the transmitted signals to same connection port (multiplex switch) or different connection ports (de-multiplex switch)

- **Why NXP?**

- Signal switch has no signal regeneration function, and it works at transistor level to redirect the passed signal. The switch architecture design highly impacts the bypassed signal integrity.
- NXP’s signal switches provide best-in-class high performance features:
 - High signal bandwidth
 - Low return loss
 - Low crosstalk
 - Low jitter disturbance

Switches Overview for USB Type-C Applications

CBTU02043/PTN36043

CBTL04GP043

CBTL08GP053

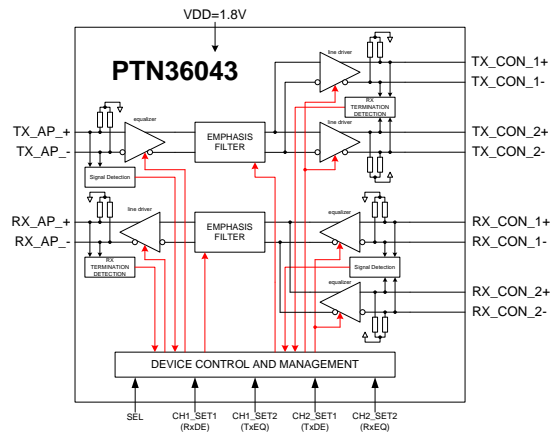
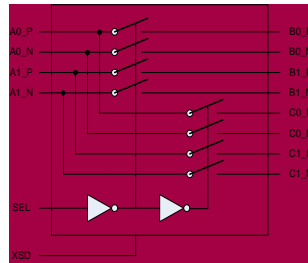

Mobile & Portable Applications

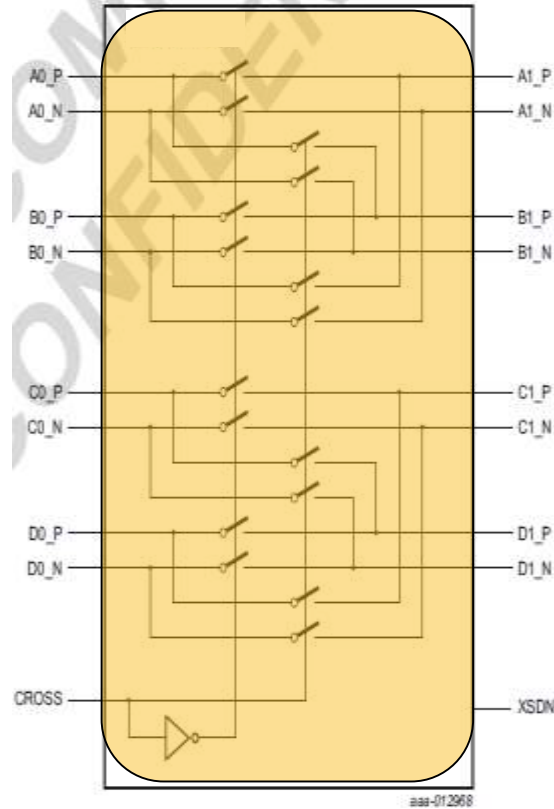

Computing Applications

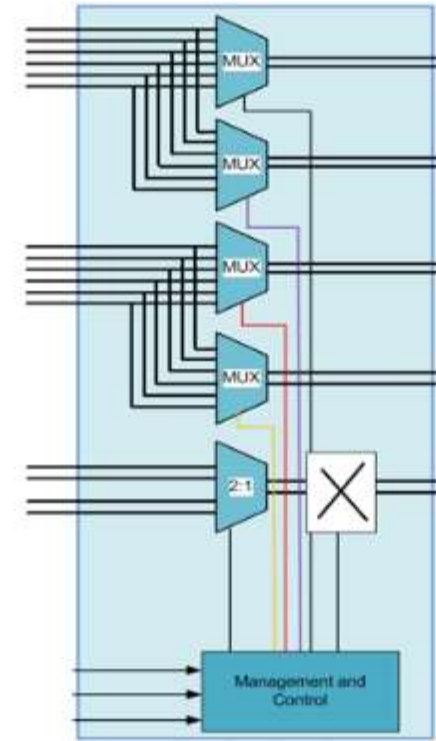

Computing & Docking Applications

CBTU02043 12 GHz High Bandwidth Switch

- 2 differential channel (or 4 single-ended) 2:1 bi-directional mux/demux
- Signaling supported
 - 10 Gbps USB3.1 Gen2, PCIe-Gen 3 signals
 - DDR signals
- Supply voltage: 1.8V - 3.3V
- Differential BW: 12 GHz
- Differential Return Loss: < -12dB @ 5GHz
- Low crosstalk: < -37dB at 5GHz
- Low Off-isolation: -20dB at 5GHz
- Low differential intra-pair skew: 6ps typical
- IDD: 200 uA (active) and 3uA (powerdown)
- CMOS select signals
- Switch/mux topology: 1:2
- ESD 2.5kV HBM, 1kV CDM
- HUQFN16 package: 2.4 x 1.6 X0.5 mm package with 0.4mm pitch

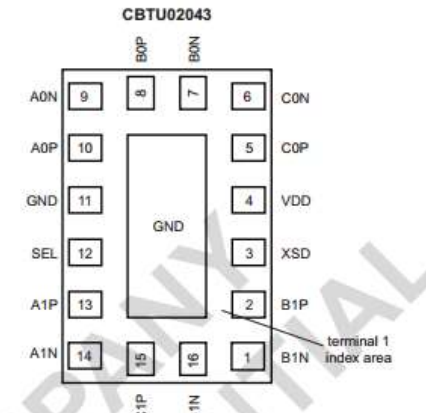
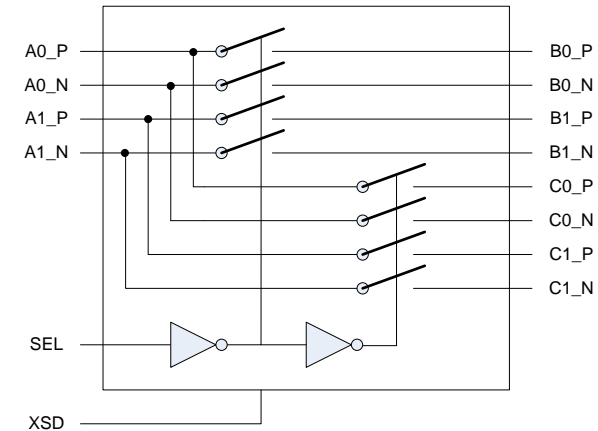

Sampling Apr'16

CBTL02043 10 GHz High Bandwidth Switch

- 2 differential channel, 2:1 bi-directional mux/demux
- Signaling Supported
 - PCIe Gen3 @ 8Gbps
- Insertion loss
 - -0.5dB at 100 MHz
 - -1.2dB at 4 GHz
 - -3.0dB at 10 GHz
- Low Return-Loss -19.4dB at 4GHz
- Low crosstalk: -28dB at 4GHz
- Low Off-isolation: -23dB at 4GHz
- Low intra-pair skew: 5ps typical
- Low inter-pair skew: 35ps max
- 3.3 V supply voltage
- DHVQFN20 package
- ESD 2kV HBM, 1kV CDM
- Two pin outs available for PCB layout optimization
- Standby current < 1 uA controlled by XSD pin

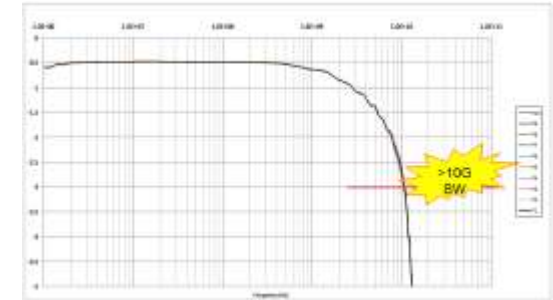
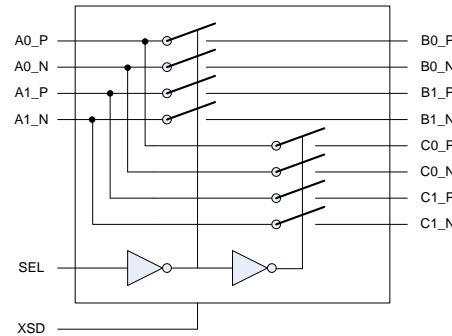

• Applications:

- Type-C connector
- PCIe Gen 3
- DisplayPort V1.2
- USB 3.0
- SATA Gen 3

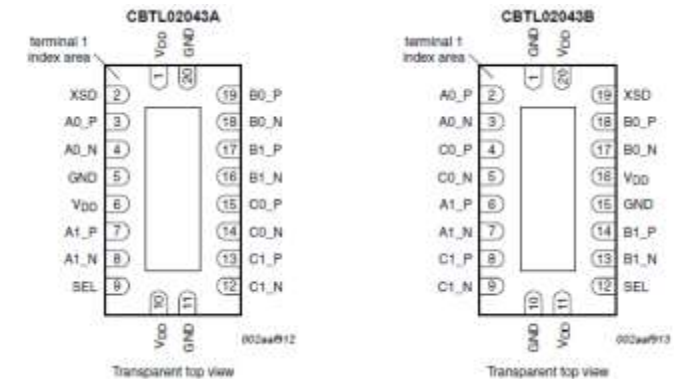

Now in Production



PTN36043- USB Type C SuperSpeed Redriver Switch

- 5Gbps USB3.0 one port redriver switch
- Compliant to SuperSpeed USB standard
- Optimized data flow for Type C connector
- Adjustable Receive equalization, Transmit de-emphasis, and output swing functions
- Low crosstalk and excellent differential and common return loss performance
- Low power management scheme
 - 189 mW (105mA) active power
 - 2.16 mW (1.2mA) in U2/U3 state
 - 0.9 mW (0.5mA) with no connection
- Power supply: $VDD=1.8V\pm 5\%$
- ESD 8kV HBM; 1kV CDM
- Operating Temperature Range: -40°C to 85°C
- Very small thin DHXQFN18 package 2.4 mm x 2.0 mm x 0.35mm, 0.4 mm pitch

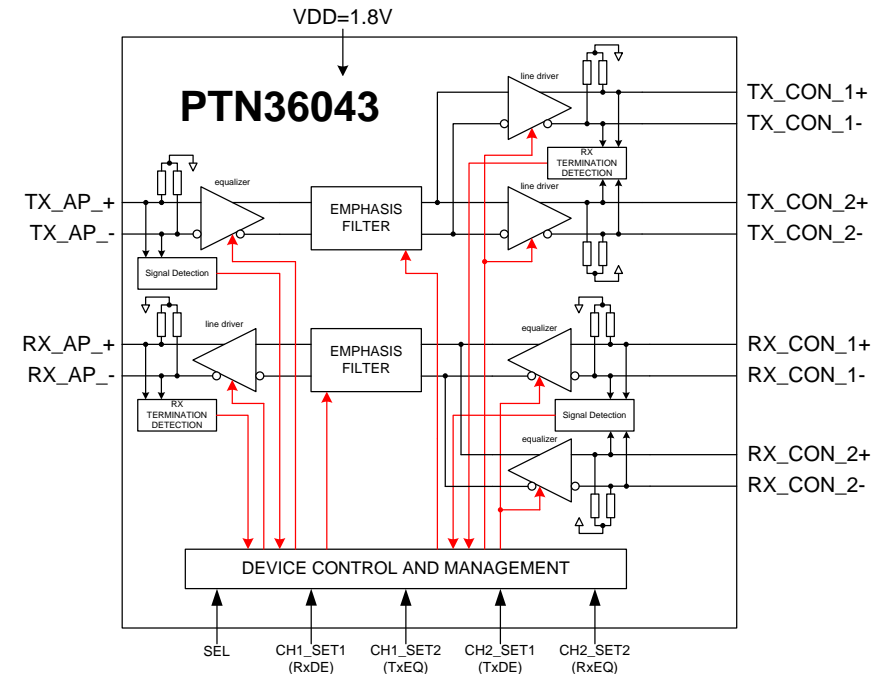

Now in Production

CBTL04GP043 - Crossbar Switch for USB Type-C Connector

- The new USB Type-C connector, built initially on existing USB 3.0 and USB 2.0 technologies, is being developed to help enable thinner and sleeker product designs.
- Key characteristics of the USB Type-C connector and cable solution include:
 - New smaller size – similar in size to the existing USB 2.0 Micro-B
 - Usability enhancements – users will no longer need to be concerned with plug orientation/cable direction, making it easier to plug in
 - The Type-C connector and cable will support scalable power charging (USB PD)

Now in Production

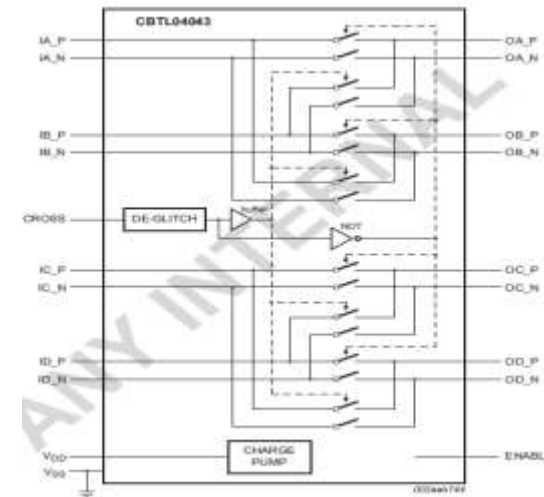

- Dual 2x2 differential channel cross bar switch
- Operating voltage range : 2.7 V to 3.5 V
- Bandwidth: 7 GHz (typical) for VIC = 0 V; 8.5 GHz (typical) for VIC = 2.2 V
- Low insertion loss, return loss and crosstalk
- Back current protection on all I/O pins of these switches
- XFBGA28 package with 0.5 mm pitch

CBTL08GP053 – USB Type-C Combo Switch

- Applications in platforms supporting Alternate Modes to transport multiple high speed signals over USB Type-C connector
- Supports data rates up to 5.4 Gbps
- Supports several use cases
 - USB3
 - USB3, DP 1/2/4-lanes
 - USB3, PCIe (1-lane)
- High Speed Mux target specs
 - Bi-directional usage support (mux or switch)
 - -3dB BW: >5 GHz
 - Insertion loss: 1.3 dB @ 2.7 GHz
 - Isolation: 25 dB @ 2.7 GHz
 - Return loss: 18 dB @ 2.7 GHz
 - Cross talk: 35dB @ 2.7 GHz
- High speed and Side band Mux support (controlled via I2C)
- Back current protection on control pins
- Side band muxes can handle up to 5V (rail to rail signaling)
- Single 3.3V supply
- Active Current consumption ~500 uA
- ESD 2kV HBM, 500V CDM
- 36-ball BGA, 0.4 mm pitch

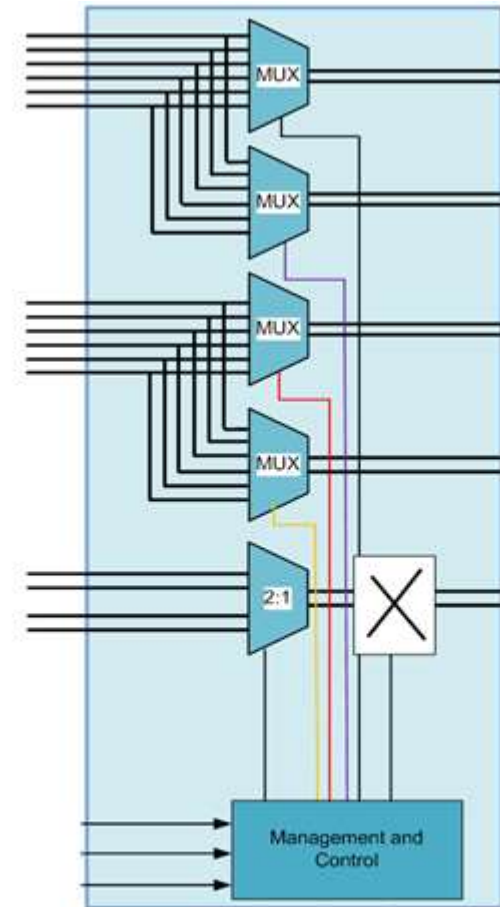

Now in Production

USB POWER DELIVERY CONTROLLER AND PROTOCOL RESPONDER



What is USB Power Delivery and Why NXP

- **What is USB PD?**

- USB PD stands for USB Power Delivery which is the goal of USB connection to provide USB data link and also power from host to device or vice versus from device to host. The maximum power delivery via USB PD 2.0 can be up to 5A and 20V through connector or 3A and 20V through USB cable.
- The USB PD protocol is also used to communicate the characteristics of the peripherals with system to establish the link operation.

- **Why is it needed?**

- USB PD to provide higher power delivery than the legacy USB spec.
- Type-C cable adaptor and full-featured Type-C cable electronic marker to communicate the product and/or cable capability information via PD protocol signal
- Alternate mode support to transport non-USB data over Type-C

- **Why NXP?**

- NXP provides optimized system partitioned products with balanced cost and performance. NXP's USB PD products and PD Firmware have robust compatibility and complete functions for
 - USB PD 2.0 Physical Layer controller
 - USB active cable or cable adaptor controller
 - USB Type-C full-featured cable electronic marker
 - USB Type-C CC logic controller

USB Type-C PD PHY and CC Logic Controller

PTN5150 CC Logic

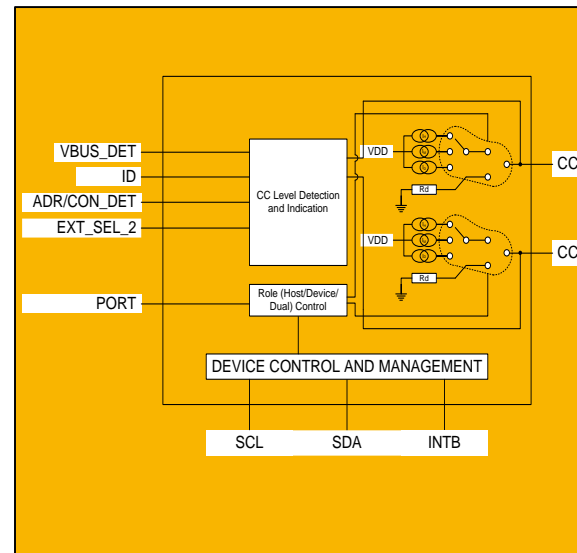

Type-C CC logic,
Legacy USB, OTG

PTN5100 PD PHY

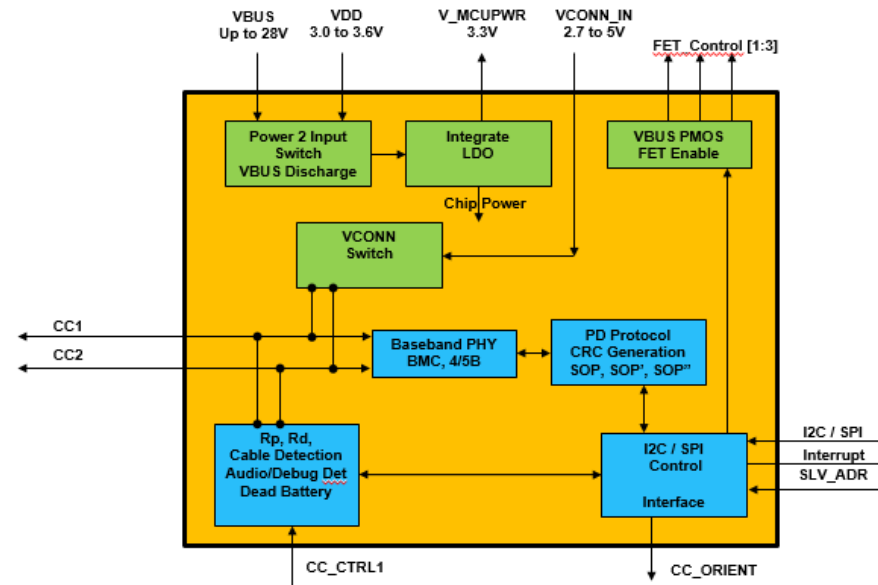

Alternate Mode &
USB Power
Delivery

PTN5100 – Type-C PD PHY and Protocol IC

- Application – USB Power Delivery
- Flexible to work with NXP or any 3rd party MCU via SPI or I2C interface
- Power control and related functions
 - VBUS (3.7-28V) for local supply
- Baseband PD functions
 - Type-C Cable/plug detection and indication (Host, Device and Dual role mode support)
 - USB PD Baseband PHY - BMC, 4B5B, Preamble, SOP, SOP', SOP'' and EOP generation/reception, CRC generation/check, GoodCRC response
 - VCONN Low RON switch (up to 5W max)
 - I2C or SPI slave interface
 - Power Supply options – VBUS or VDD/VIO
 - Package HVQFN20 4mm x 4mm, 0.4 mm pitch

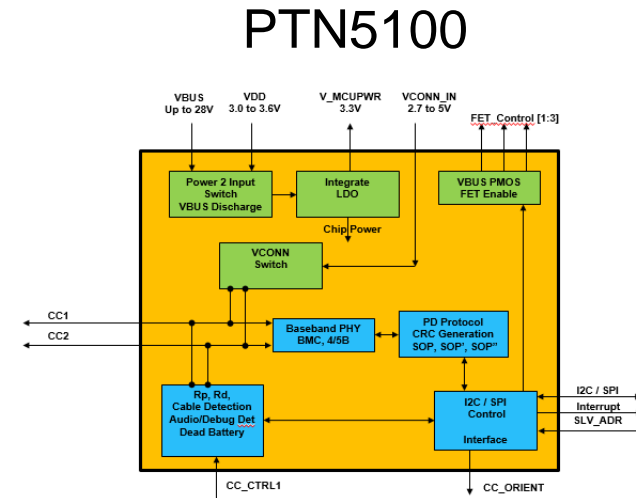

* Paired with NXP LPC11xx MCU series or embedded system controller (EC)

Production Now

PTN5150 CC Logic Controller

- CC logic control supports plug detection, orientation detection, role identification and charging current detection
- Support USB ID(OTG) output
- Selectable Dual Role or Device only control
- Support VCONN PFET control
- Operating current: < 40uA;
- Shut down current: 5uA
- VDD supply voltage range: 2.7v to 5.5v
- Supports Software Try.Sink
- Small Thin X2QFN12 package 1.6mm X1.6mm X0.35mm with 0.4mm pitch

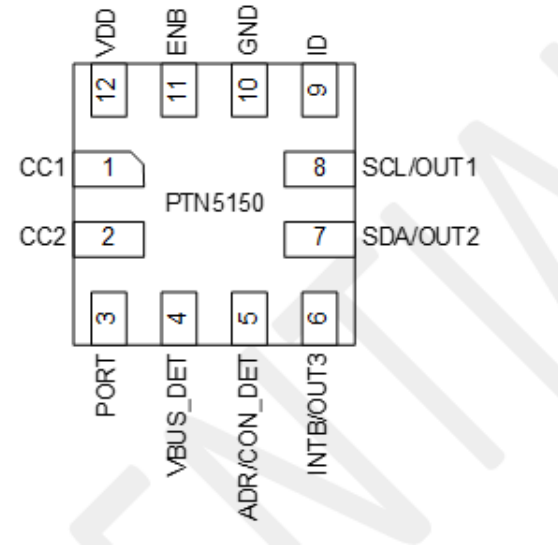

Same pin assignment as Qualcomm's reference design (TI/Pericom compatible)

Production Now

PTN5150 System Application

Support USB OTG, USB3 Connection Flip, USB Type-C Fast Charging and Vconn Power Enable

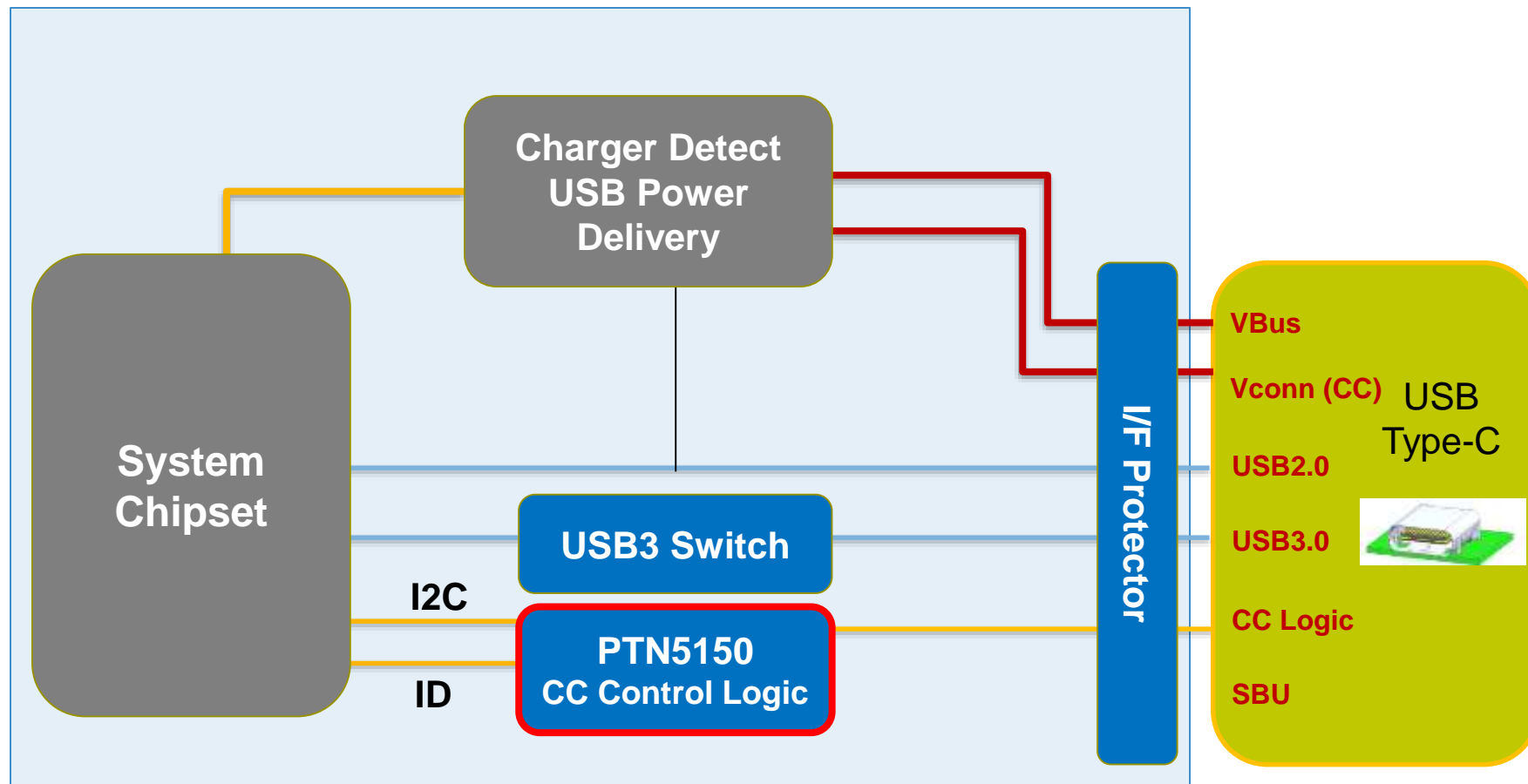

USB LOAD SWITCHES

What Are the USB Type-C Load Switches and Why NXP?

- What is the Type-C Load Switch product?
 - Advanced unidirectional N-channel power switch designed to automatically isolate a system from a faulty source or load. It includes under-voltage protection, reverse current protection, over-temperature protection, programmable over-voltage protection, and/or programmable current limit.
- Why is it needed?
 - Type-C load switches provide protection for 2 main use cases:
 - Consumer use-case where the notebook is being charged. The load switches protects the system from OVP surges from faulty wall adapter or external supply, and reverse connector plug-in.
 - Provider use-case where the notebook is providing power to an external load (such as On-The-Go). The load switch protects the system from overcurrent, short circuits, and reverse currents caused by a faulty load or upside-down connector plug-in.
- Why NXP?
 - NXP provides simple to implement, yet robust and affordable solutions in a variety of packages

USB Type-C/PD Power Switch in System

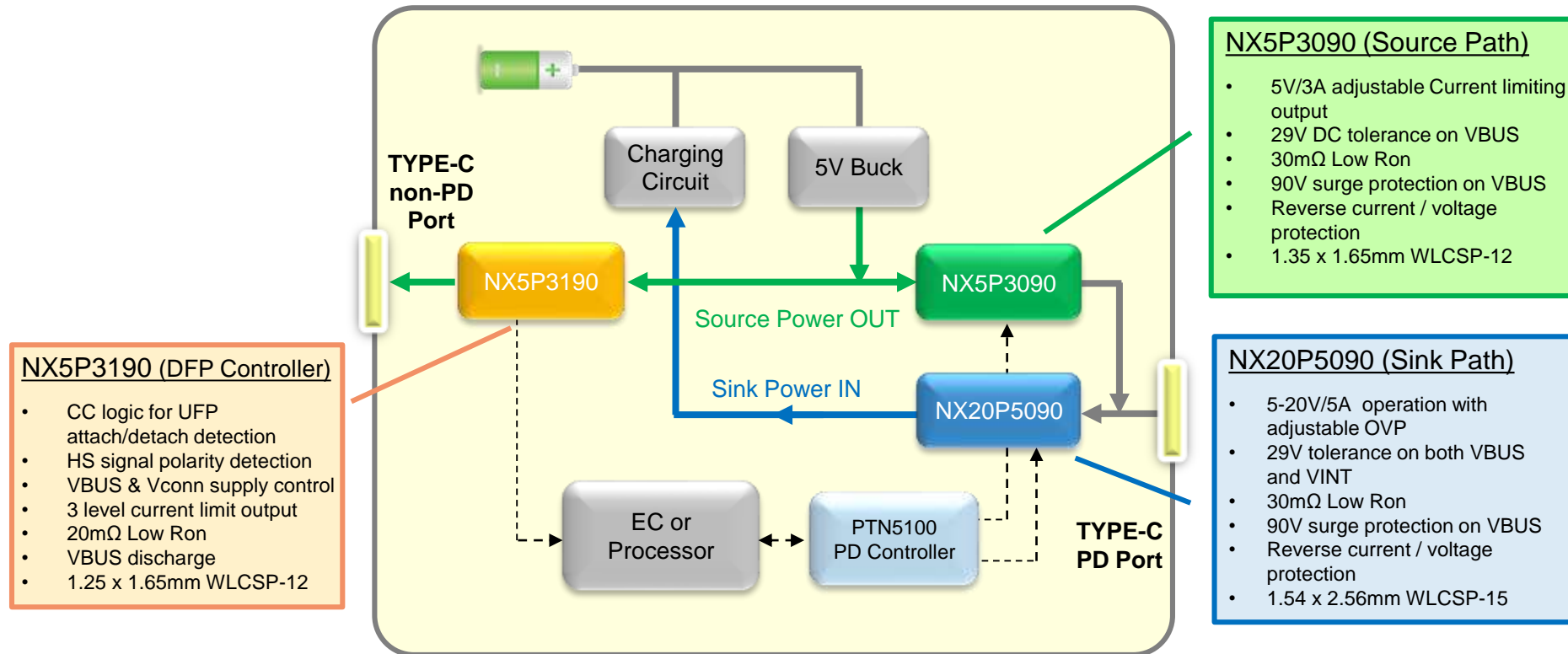

VBUS Sink Path: Feature Comparison

Load Switch Value Proposition vs. Discrete Approach

Features		NX20P5090	Competitor C – 2pcs back-to-back Pch FET
VBUS Power FET	Flat Rdson over supply and temperature	30 mohm across Vbus (built-in driver)	30mohm Rdson at -4.5V x2pc = 60mohm
External drivers	Logic controlled Power MOSFET	Driver is integrated	2 pcs External Nch FET
Over-voltage protection	built in OVP	programmable OVP is integrated	1pc External TVS diode 100V tolerant
	Inductive Surge protection against cable disconnect	80V IEC-6100-4-5 surge integrated	
all time Reverse current protection	protects against current backflow	All time RCP is integrated	Need external circuit

VBUS Source Path: Feature Comparison

Features		NX5P3090	Competitor C – back-to-back Pch FET
VBUS Power FET	Flat Rdson over supply and temperature	30 mohm across Vbus (built-in driver)	30 mohm Rdson at -4.5V x2pc = 60mohm
External drivers	Logic controlled Power MOSFET	Driver is integrated	2 pcs External Nch FET
Current limit protection	built in OCP	programmable OCP is integrated	need external current monitor
all time Reverse current protection	protects against current backflow	All time RCP is integrated	Need external circuit

Size Comparison

VBUS Sink Path: Size Comparison

Features		NX20P5090	Competitor C – 2pcs back-to-back Pch FET
VBUS Power FET	Flat Rdson over supply and temperature	4 mm ²	2 pcs 3.3x3.3mm = 21.8mm cost = \$0.09x2 = \$0.16
External drivers	Logic controlled Power MOSFET	Driver is integrated = 0mm no extra cost	2 pcs SOT23 – 2.4x2.9mm = 13.9mm cost = \$0.02x2 = \$0.04
Over-voltage protection	built in OVP	OVP is integrated = 0mm no extra cost	1pc External TVS diode 100V tolerant
	Inductive Surge protection against cable disconnect	surge integrated = 0mm no extra cost	1pcs 4x5mm= 20mm \$0.04-0.05
all time Reverse current protection	protects against current backflow	RCP is integrated = 0mm no extra cost	1 pc 2.5x4mm = 10mm cost= \$0.03-0.04

VBUS Source path: Size Comparison

Features		NX5P3090	Competitor C – 2 back-to-back Pch FET
VBUS Power FET	Flat Rdson over supply and temperature	1.36x1.65mm = 2.2 mm ²	2 pcs 3.3x3.3mm = 21.8mm cost = \$0.09x2 = \$0.16
External drivers	Logic controlled Power MOSFET	Driver is integrated = 0mm no extra cost	2 pcs SOT23 – 2.4x2.9mm = 13.9mm cost = \$0.02x2 = \$0.04
Current limit protection	Built in OCP	programmable OCP is integrated no extra cost	need external current monitor
all time Reverse current protection	protects against current backflow	RCP is integrated no extra cost	1 pc 2.5x4mm = 10mm cost= \$0.03-0.04

NX20P5090 – 5A Programmable OVP USB PD Power Switch

Description

- 5.0A capable power switch with externally programmable over-voltage protection. OVLO is programmed via pull-down resistor. It also includes under-voltage protection, reverse current protection, and over temperature protection. During a fault condition, device opens to protect the load. Device has slew rate control with 15 ms debounce time before the switch turns on. Enable input integrates logic translation making the device compatible with lower voltage processors
- It is designed to operate from 2.5V to 20 V, to support USB PD Type C and power domain isolation applications with high supply currents.
- **Available in:** WLCSP15 1.6 x 2.6 mm, 0.5 mm pitch

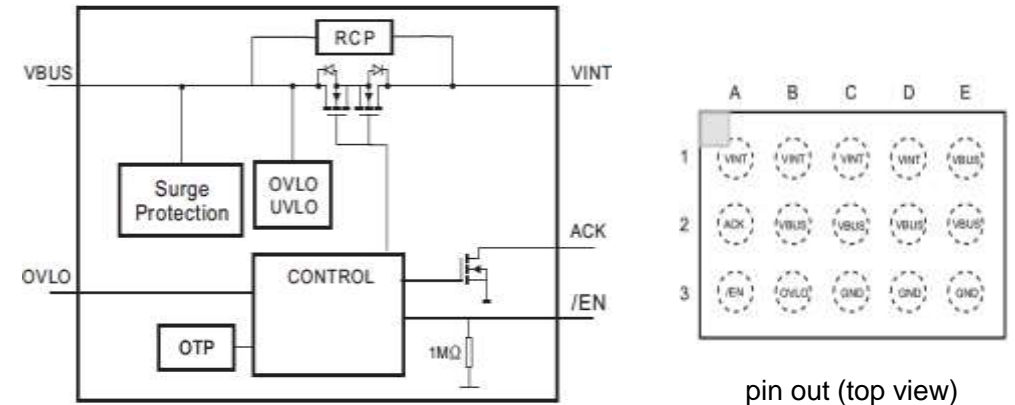

Production Now

block diagram

Features

- Operates from 2.5 to 20 V.
- Low ON resistance: Ron typ 30 mΩ
- 29V tolerant both VINT&VBUS pins
- Reverse current protection
- Programmable over-voltage protection
- Under voltage protection
- Over-temperature protection @140C
- 1.8V control Logic to enable/disable
- 90V Surge Protection
- Slew rate control with 15 ms debounce



NX20P5090 Vs. Discrete Power MOSFET

	NXP20P5090	Back to Back PMOS	NX20P5090 Added Value in System design
ON/OFF control	GPIO control	Need external driving circuit	Can be directly controlled by USB Controller
Reverse Current Protection	Yes	No	Protect the system during charging source switching or multi channels being enabled at same time
Over Voltage Protection	Yes	No	Protect the system from abnormal high charging voltage
Surge Protection	Yes	No	Protect the system from surge power during plug in/out or electric grid surge.
Under Voltage Lockout	Yes	No	Automatically switch off the channel when no valid voltage applied on VBUS pin
VBUS De-bounce Time	Yes	No	Protect the system from VBUS instability right after plug-in
Over Temperature Protection	Yes	No	Self Protection from over heating
Solution Size	Very small	Large	Save the PCB space

NX5P3090 – 3A, Adjustable Current Limit Power Switch

Description

- Power switch with externally programmable current limit. During over-current situations, device clamps the current to a value set by external resistor. Current limit value can be adjusted from 500mA to 3.0A. Device also includes reverse current protection, under voltage lockout, over-temperature protection, and soft start.
- Enable input integrates logic translation making the device compatible with lower voltage processors.
- Designed for operation from 3.0 V to 5.5 V, and the output terminal is 29V tolerant to support USB PD rails.
- **Available in:** WLCSP12 1.35 x 1.65, 0.4 mm pitch

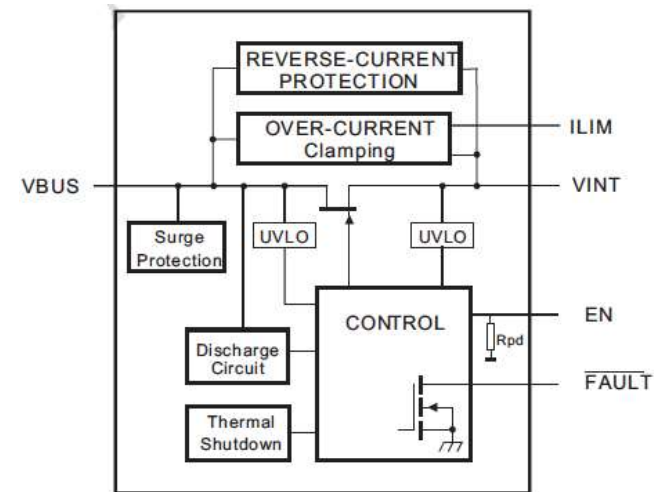

block diagram

Samples in Feb

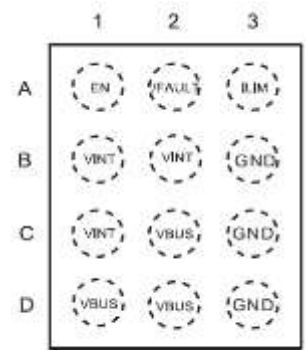

Transparent Top View

Features

- Operates from 2.5 to 5.5 V
- Low ON resistance: Ron typ 30 mΩ
- 29V tolerant on VBUS pins
- UVLO protection
- Reverse current protection
- Adjustable current limit 0.5 to 3.0A
- Over-temperature protection @140C
- 1.8V control Logic to enable/disable
- Soft start turn-on, slew rate controlled

NX5P2190 – Current Limit Power Switch

Description

- Uni-directional power switch for USB VBUS supply current limit.
- Operates from 3.0 to 5.5V. Protect the inside circuitry from external voltages up to 30 V. The over-current protection circuit's (OCP) trigger value I_{ocp} , is set using an external resistor connected to the ILIM pin
It is designed to isolate a VBUS voltage source from an interface pin during over-current or over-temperature events. It features an externally adjustable current limit; an output voltage detect, OVP, OTP, and a fault indicator.
- **Available in:** WLCSP9 1.36 x 1.36, 0.4 mm pitch

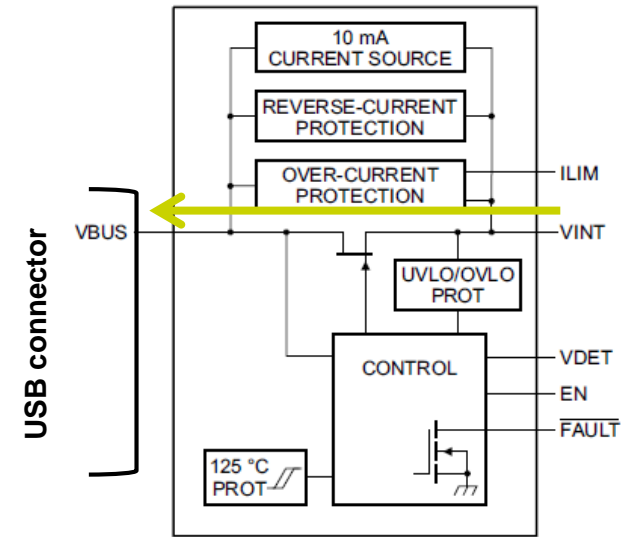

	1	2	3
A	VINT	VDET	VBUS
B	VINT	FAULT	VBUS
C	EN	GND	ILIM

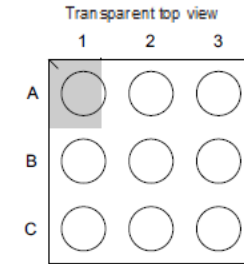

1.36 x 1.36 mm

Available Now

Features

- Isolates/protects up to 30V on VBUS
- Operates from 3.0 - 5.5 V
- Adjustable current limit
 - NX5P2090 200 mA – 2.0 A
- Low ON resistance: R_{on} 60 m Ω
- Soft start turn-on, slew rate controlled
- Over-/under-voltage protection
- Over-temperature protection @125C
- Reverse bias current protection
- ESD IEC contact to 8kV



NX5P3190 – TYPE-C (non-PD) DFP Controller With Power Switch

Description

- The NX5P3190 is a USB Type-C Downstream Facing Port (DFP) controller with an adjustable current-limiting power switch. It monitors the CC lines of Type-C port for an Upstream Facing Port (UFP). When an UFP is attached, NX5P3190 will enable the power switch to supply VBUS to the UFP.
- provides three levels of current limit by connecting an external resistor of different value between ILIM pin and GND pin. The selected source current capability will be communicated to the attached UFP through CC line.
- The device includes under voltage lockout, over-current protection and over-temperature protection circuits to automatically protect the power system when a fault condition occurs.
- **Available in:** WLCSP-12 1.25 x 1.65, 0.4 mm pitch

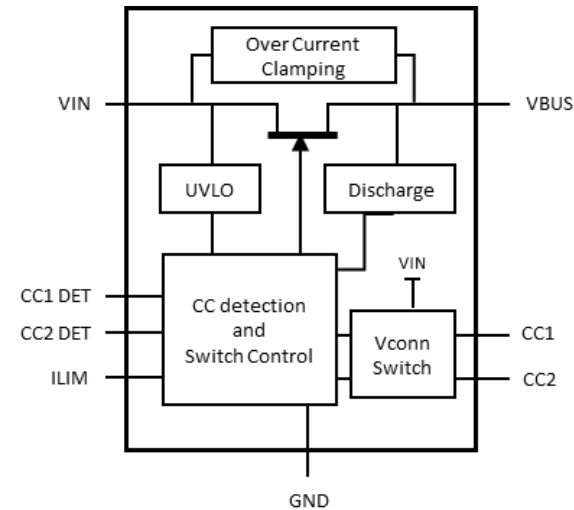

block diagram

NX5P3190			
	1	2	3
A	CC1 DET	CC2 DET	ILIM
B	VIN	VIN	GND
C	VIN	VBUS	CC2
D	VBUS	VBUS	CC1

Transparent Top View

Samples Q2'16

Features

- USB Type-C DFP solution comply with TYPE-C v1.1
 - UFP Attach/Detach detection
 - Super speed line polarity determination
 - VBUS and VCONN supply control
 - Debug mode identification
- Operates from 4.0 to 5.5 V
- Three current limit threshold: 1A, 1.7A and 3.3A.
- Low ON resistance: Ron typ 20 mΩ
- VBUS discharge after detach with time out control

KEY COMPETITIVE ADVANTAGE

Key Competitive Advantage

NXP USB Type-C solution Advantage

- NXP offers the entire USB Type-C solution. Most of competitors only offer products in one or two categories, but not all.
 - USB Type-C CC logic + PHY (PTN5100)
 - USB PD Controller with PD Firmware (LPC1115)
 - High Speed USB and DisplayPort Switch (CBTL08GP053)
 - 20V load switch (NX20P5090)
 - ESD protection device
- NXP provides reference design guide to help customer address any USB Type-C design requirement and challenges.
- NXP provides PD controller and firmware.
 - Customer can get reference design for HOST & DEVICE implementation
 - Request firmware porting service
- NXP support and prepare customers get ready for USB/IF compliance testing.



SECURE CONNECTIONS
FOR A SMARTER WORLD

ATTRIBUTION STATEMENT

NXP, the NXP logo, NXP SECURE CONNECTIONS FOR A SMARTER WORLD, CoolFlux, EMBRACE, GREENCHIP, HITAG, I2C BUS, ICODE, JCOP, LIFE VIBES, MIFARE, MIFARE Classic, MIFARE DESFire, MIFARE Plus, MIFARE Flex, MANTIS, MIFARE ULTRALIGHT, MIFARE4MOBILE, MIGLO, NTAG, ROADLINK, SMARTLX, SMARTMX, STARPLUG, TOPFET, TrenchMOS, UCODE, Freescale, the Freescale logo, AltiVec, C 5, CodeTEST, CodeWarrior, ColdFire, ColdFire+, C Ware, the Energy Efficient Solutions logo, Kinetis, Layerscape, MagniV, mobileGT, PEG, PowerQUICC, Processor Expert, QorIQ, QorIQ Qonverge, Ready Play, SafeAssure, the SafeAssure logo, StarCore, Symphony, VortiQa, Vybrid, Airfast, BeeKit, BeeStack, CoreNet, Flexis, MXC, Platform in a Package, QUICC Engine, SMARTMOS, Tower, TurboLink, and UMEMS are trademarks of NXP B.V. All other product or service names are the property of their respective owners. ARM, AMBA, ARM Powered, Artisan, Cortex, Jazelle, Keil, SecurCore, Thumb, TrustZone, and μ Vision are registered trademarks of ARM Limited (or its subsidiaries) in the EU and/or elsewhere. ARM7, ARM9, ARM11, big.LITTLE, CoreLink, CoreSight, DesignStart, Mali, mbed, NEON, POP, Sensinode, Socrates, ULINK and Versatile are trademarks of ARM Limited (or its subsidiaries) in the EU and/or elsewhere. All rights reserved. Oracle and Java are registered trademarks of Oracle and/or its affiliates. The Power Architecture and Power.org word marks and the Power and Power.org logos and related marks are trademarks and service marks licensed by Power.org. © 2015–2016 NXP B.V.

