

Xtrinsic Sensor Fusion

# Xtrinsic FXOS8700CQ 6-Axis Sensor

## Typical Applications

- Electronic compasses
- Enhanced user interfaces
- Smartphones
- Tablets
- Personal navigation devices
- Augmented reality
- Mobile device peripherals
- 12-axis Xtrinsic sensor platform for Windows 8
- Drivers available for leading operating systems
- Gaming

## Xtrinsic eCompass and Calibration Software

- Tilt compensation
- Euler angles, rotation matrix and quaternion outputs
- Full range of magnetic calibration models from four to 10 elements
- Virtual gyro capability
- Compatible with Android™ and Windows 8 requirements

## Single-package 3-axis accelerometer and magnetometer

### Overview

The Freescale FXOS8700CQ 6-axis Xtrinsic sensor combines industry-leading accelerometer and magnetometer sensing in a small 3 x 3 x 1.2 mm QFN plastic package. Applications include electronic compass, enhanced user interface, augmented reality and location-based service applications (static geographic heading). Target products include smartphones, tablets, personal navigation devices, remote controls for smart TVs, watches, gaming controllers, robotics and unmanned air vehicles (UAVs).

In addition, Freescale is developing a 12-axis Xtrinsic sensor platform for Windows 8 integration into tablets, slates, convertible/non-convertible laptops and other portable devices.

The FXOS8700CQ combines a 14-bit accelerometer and 16-bit magnetometer with an optimized ASIC to enable a high-performance eCompass solution capable of a typical orientation resolution of 0.1 degrees and sub-5-degree compass heading accuracy for most applications.

## Xtrinsic FXOS8700CQ 6-Axis Sensor Block Diagram

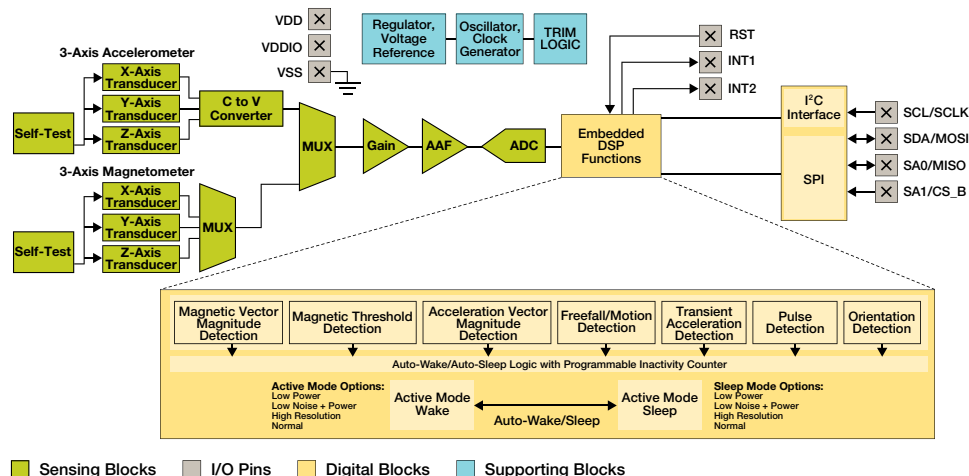

The FXOS8700CQ 6-axis sensor incorporates the industry's most advanced embedded features, allowing the entire system to be optimized for low power with substantially more savings when the application processor power modes are driven by sensor interrupt signals. Selectable output data rates (ODR) from 1.563 Hz to 800 Hz per sensor, or up to 400 Hz in hybrid mode (simultaneous accelerometer and magnetometer data) offer significant respective power savings at lower ODRs.

## Xtrinsic eCompass Software

Advanced Xtrinsic eCompass software is available for the FXOS8700Q 6-axis sensor with the four, seven and 10 element magnetic calibration algorithms models.

The four parameter version is suited for applications with hard iron interference only or where minimal power consumption is required. The seven parameter model adds support for soft iron gain distortion and is suitable for the vast majority of consumer eCompass applications. The 10 parameter model adds support for cross-axis soft iron distortion and is targeted at the most complex smartphone PCBs. To download the eCompass software, visit [freescale.com/eCompass](http://freescale.com/eCompass).



## Features and Benefits

Features	Benefits
Highly integrated	FXOS8700CQ 6-axis sensor combines industry-leading accelerometer and magnetometer sensors into a single 3 x 3 x 1.1 mm package
Wide dynamic range $\pm 1200 \mu\text{T}$	Flexibility in placement on PCBs that incorporate permanent magnets such as speakers and vibrator motors
Embedded vector magnitude detection	Significant system-level power savings is achieved by embedded vector magnitude detection that interrupts the host for programmable orientation change and/or magnetic interference/magnet presence detection
Embedded autonomous hard iron calibration	Low-power hard iron offset compensation for platforms dominated by hard iron magnetic interference
Low power consumption	Selectable output data rates ranging from 1.563 Hz to 800 Hz for each sensor allows for the optimum trade-off between power consumption and performance (response time). Programmable auto-wake/sleep works with all internal interrupt sources, including the magnetic event detection blocks to save significant power.
High performance	Industry-leading 14-bit accelerometer and 16-bit magnetometer are combined with a high-performance ASIC to enable a high-performance eCompass solution capable of a typical heading resolution of 0.1 degrees and sub-5-degree heading accuracy for most applications. Operates at up to 400 Hz with both sensors active in a hybrid mode. Embedded functionality using g-cell and m-cell combined data for a cost efficient, customizable and optimized solution.
Xtrinsic eCompass software	Floating point and integer code that supports all standards including Android, Windows 8 and other operating systems
Xtrinsic calibration software	Full range of power and performance of floating point and integer four, seven and 10 element models

## Documentation

Document	Description
FXOS8700CQ data sheet	Specifications for the Xtrinsic 6-axis sensor
AN4458	Using the Xtrinsic FXOS8700CQ accelerometer and magnetometer vector magnitude function
AN4459	Using the Xtrinsic FXOS8700CQ auto-calibration function
AN4461	Using the Xtrinsic FXOS8700CQ transient-acceleration function

## Development Tools

Kit Number	Description
LFSTBEB8700	The LFSTBEB8700 contains two PCBs: FXOS8700CQ single package accelerometer and magnetometer daughter card and the sensor interface board. Customers may purchase the LFSTBUSB communication board separately.
RD4247FXOS8700	The RD4247FXOS8700 is a complete kit containing three PCBs: FXOS8700CQ single package accelerometer and magnetometer daughter card, sensor interface board and LFSTBUSB communication board.

## Freescale: A Leader in Sensing Solutions

Expanding on more than 30 years of sensor innovation, our Xtrinsic sensing solutions are designed with the right combination of high-performance sensing capability, processing capacity and customizable software to help deliver smart, differentiated sensing solutions. With Xtrinsic sensors, our vision is to offer a diverse and differentiated product portfolio to meet the expanding needs of the automotive, consumer and industrial segments. Xtrinsic solutions offer ideal blends of functionality and intelligence designed to help our customers differentiate and win in highly competitive markets.

For more information, visit [freescale.com/FXOS8700CQ](http://freescale.com/FXOS8700CQ)

Freescale and the Freescale logo are trademarks of Freescale Semiconductor, Inc., Reg. U.S. Pat. & Tm. Off. Xtrinsic is the trademark of Freescale Semiconductor, Inc. All other product or service names are the property of their respective owners. © 2010–2012 Freescale Semiconductor, Inc.

Document Number: FXOS8700CQFS REV 0

