

Table of Contents	
1	TITLE PAGE
2	NOTES
3	KW38 with PA
4	OpenSDA

Revisions			
Rev	Description	Date	Approved
X1	Initial Release	24/06/2019	A. Quiroz
X2	Dec Caps added to VDD_RF section Diode to power D2 added MikroBUS signals updated (LLWU,ADC,PWM) Shunts added near K22 SP1_1 pins	27/06/2019	A. Quiroz
X3	Layout release	21/08/2019	A. Quiroz
X4	Matching update	01/11/2019	A. Quiroz
A	Release files	7/02/2020	A. Quiroz
A1	Antenna layout update	14/2/2020	A. Quiroz
A2	R12,R13,R19,R25,R33,C44,C45,C48,C45-68, TP15,L6,L7 move to DNP	7/4/2020	A. Quiroz

X-KW38-ER-RD

		6501 William Cannon Drive West Austin, TX 78725-6598	
This document contains information proprietary to NXP and shall not be used for engineering design, procurement or manufacture in whole or in part without the express written permission of NXP Semiconductors.			
Designer: Antonio Quiroz	Drawing Title: X-KW38-ER-RD	ICAP Classification: CP:	IND: X PUBE:
Drawn by: Antonio Quiroz	Page Title: TITLE PAGE		
Approved: Matthew Baudry	Size: C	Document Number: SCH-43117 PDF: SPF-43117	Rev: A2
Date: Tuesday, April 07, 2020		Sheet 1 of 4	

1. Unless Otherwise Specified:
 - All resistors are in ohms, 5%, 1/8 Watt
 - All capacitors are in uF, 20%, 50V
 - All voltages are DC
 - All polarized capacitors are aluminum electrolytic
2. Interrupted lines coded with the same letter or letter combinations are electrically connected.
3. Device type number is for reference only. The number varies with the manufacturer.
4. Special signal usage:
 - _B Denotes - Active-Low Signal
 - <> or [] Denotes - Vectored Signals
5. Interpret diagram in accordance with American National Standards Institute specifications, current revision, with the exception of logic block symbology.



EAP Classification: CP: BUC: X PUB:		
Drawing Title: X-KW38-ER-RD		
Page Title: NOTES		
Size: C	Document Number: SCH-43117 PDF: SFF-43117	Rev: K2
Date: Tuesday, April 07, 2020	Sheet: 2	of 4

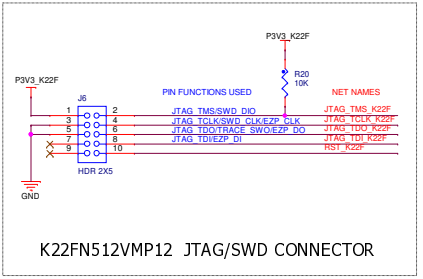
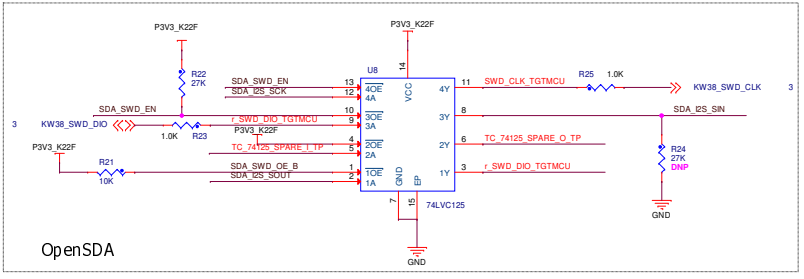
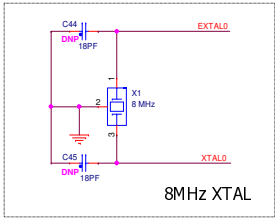
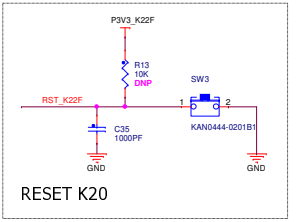
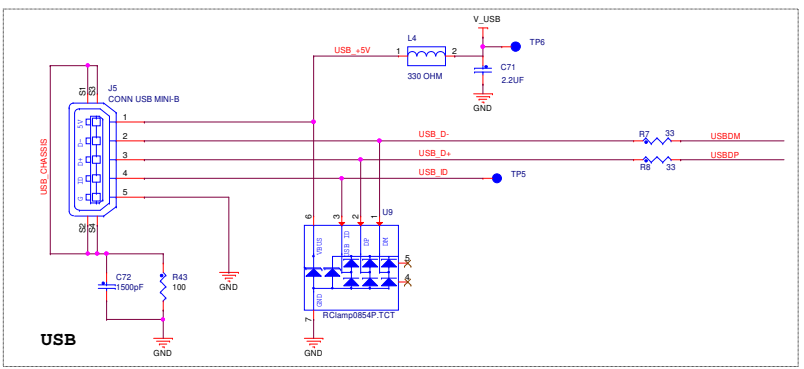
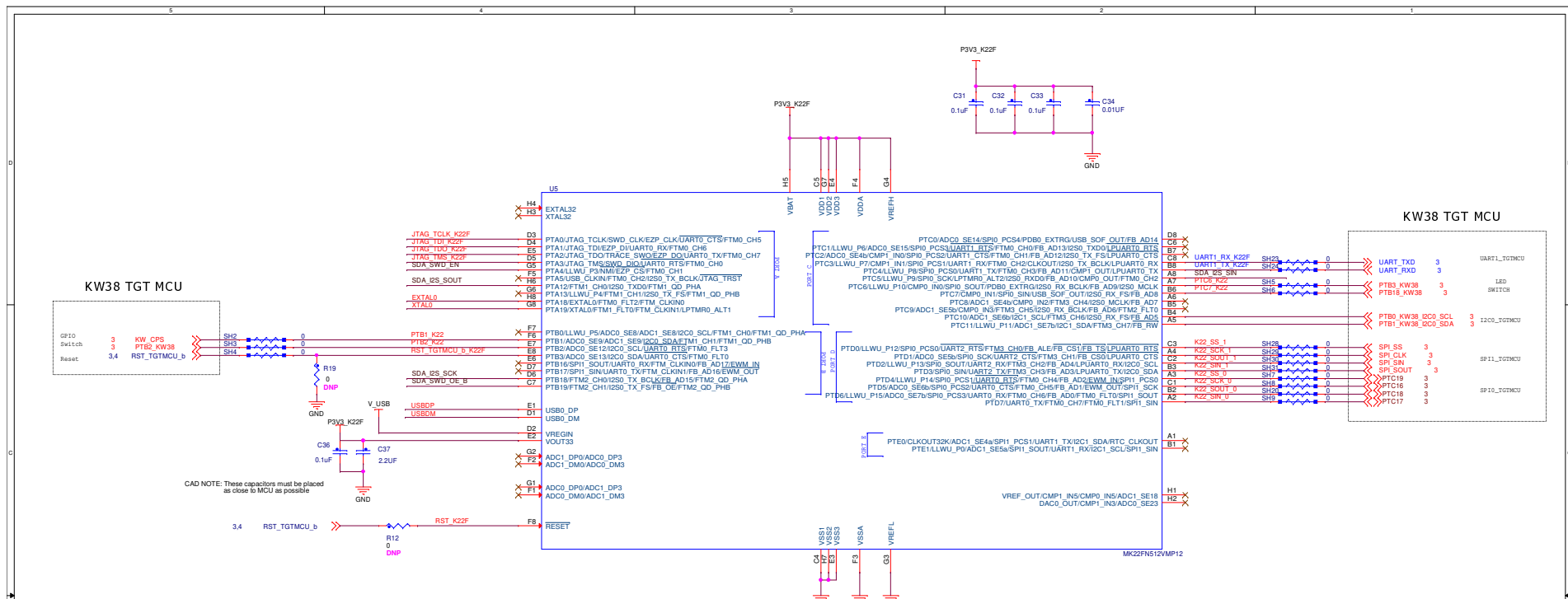

KW38 TGT MCU

D8	UART1_RX_K22F	SH2	0	UART1_RX	3	UART1_TGTMCU
H7	UART1_TX_K22F	SH3	0	UART1_TX	3	UART1_TGTMCU
C8	SDA_S2_SIN	SH4	0	SDA_S2_SIN	3	LED SWITC
A7	PTB3_KW38	SH5	0	PTB3_KW38	3	LED SWITC
B6	PTB6_KW38	SH6	0	PTB6_KW38	3	LED SWITC
A6	PTB8_KW38	SH7	0	PTB8_KW38	3	LED SWITC
B5	PTB9_KW38	SH8	0	PTB9_KW38	3	LED SWITC
B4	PTB10_KW38	SH9	0	PTB10_KW38	3	LED SWITC
A5	PTB11_KW38	SH10	0	PTB11_KW38	3	LED SWITC
C3	K22_SS_1	SH11	0	K22_SS_1	3	SPI_SS
A4	K22_SCK_1	SH12	0	K22_SCK_1	3	SPI_CLK
C2	K22_SOUT_1	SH13	0	K22_SOUT_1	3	SPI_SIN
B3	K22_SIN_1	SH14	0	K22_SIN_1	3	SPI_SOUT
A3	K22_SS_0	SH15	0	K22_SS_0	3	PTC19
C1	K22_SCK_0	SH16	0	K22_SCK_0	3	PTC16
B2	K22_SOUT_0	SH17	0	K22_SOUT_0	3	PTC18
A2	K22_SIN_0	SH18	0	K22_SIN_0	3	PTC17