

REVISIONS			
REV	DESCRIPTION	DATE	APPROVED
A	Release to proto build brd assemblies	04/10/2016	
B	Replace U2 & U3 with single TJA1059 Add R6, R7, TP1, TP2; sht 2. Reorder RefDes	12/11/2016	
C	Add JP3 - JP6 for CAN termination	1/8/2017	

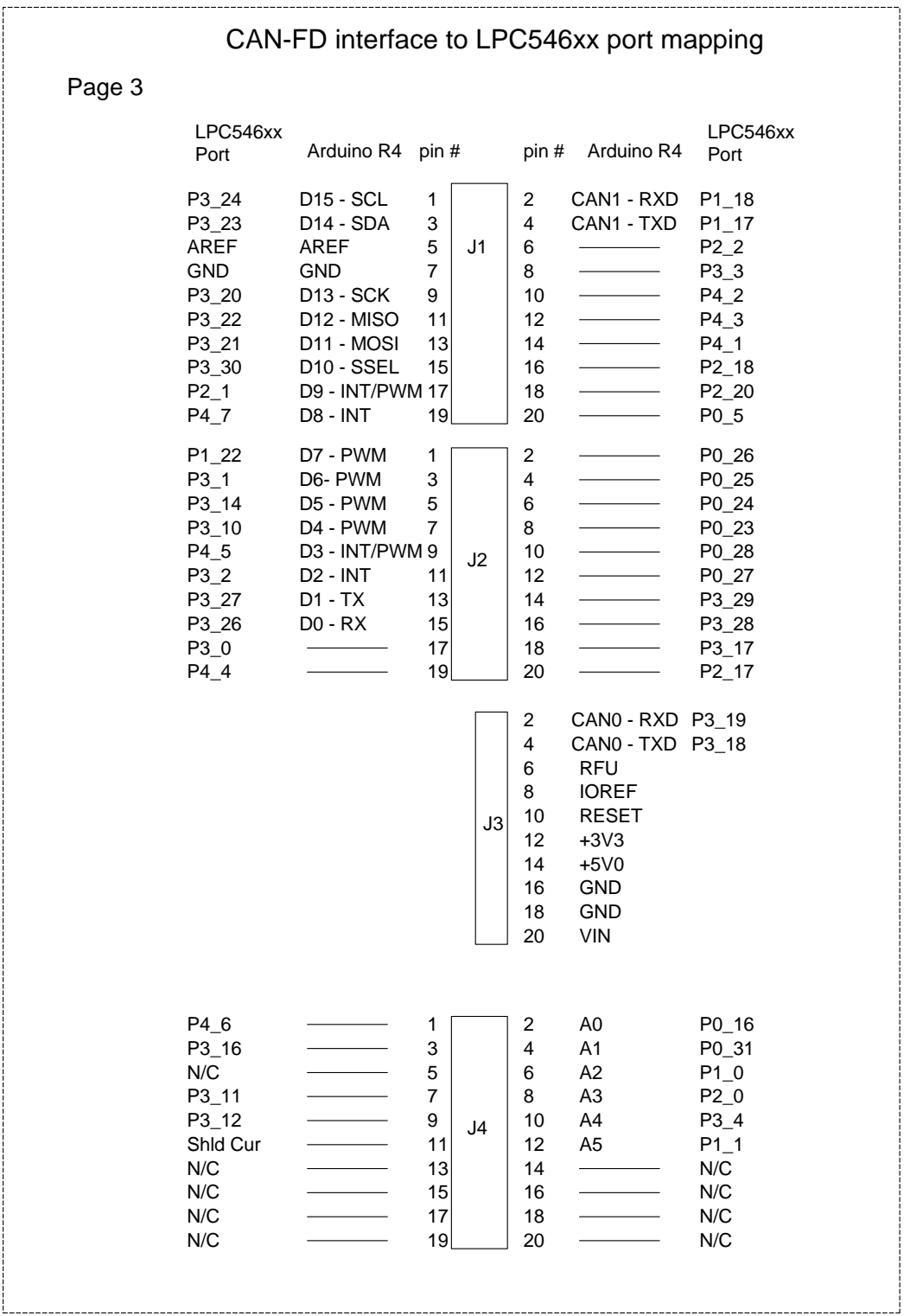

CONTRACT NO.		CAN FD Shield	
APPROVALS	DATE	NXP Semiconductors 411 E. Plumeria Dr San Jose, CA 95134 www.standardics.nxp.com/microcontrollers/	
DRAWN	1/8/2017		
CHECKED			
ISSUED	1/8/2017	SIZE	REV
		D	CANFD-01 C
		SCALE	SHEET 1 OF 03

REVISIONS			
REV	DESCRIPTION	DATE	APPROVED

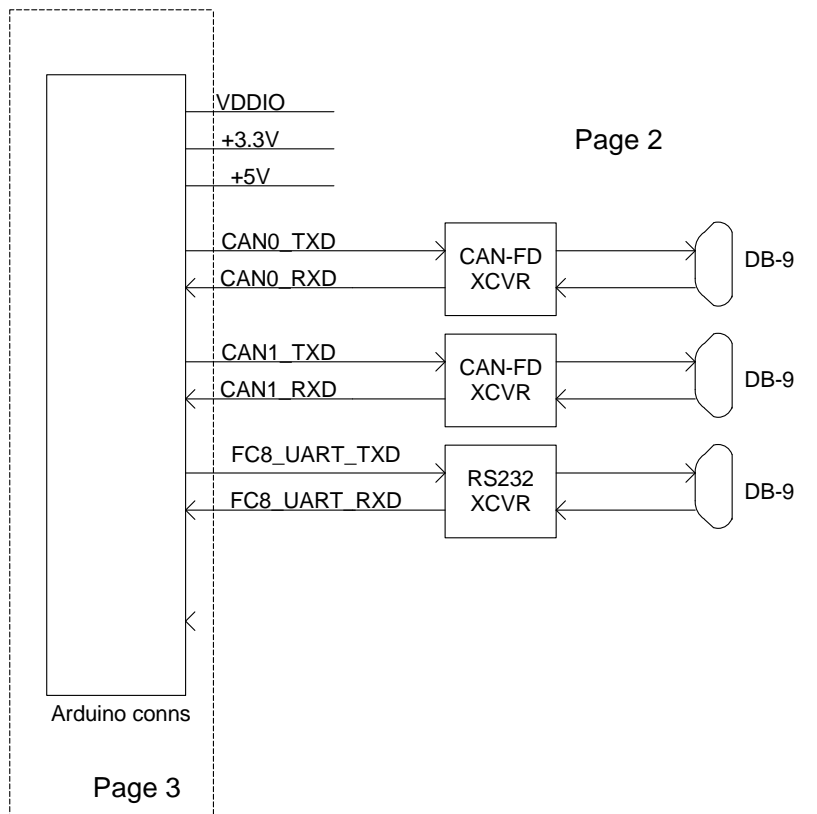
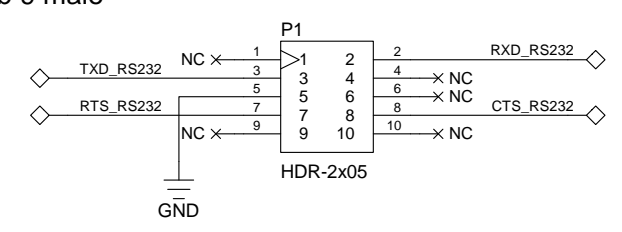
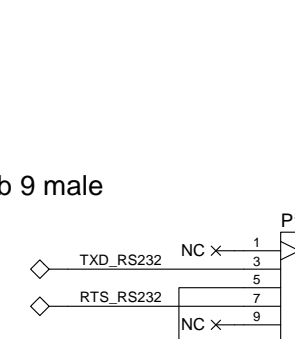
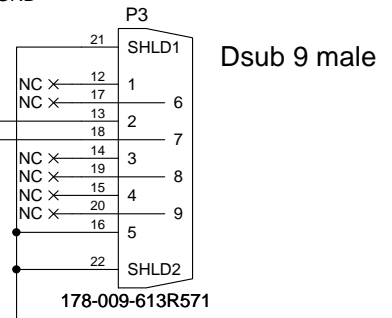
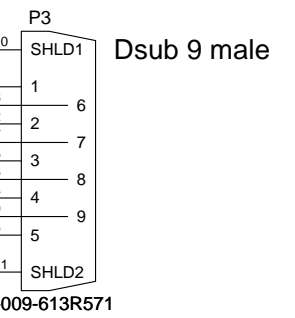
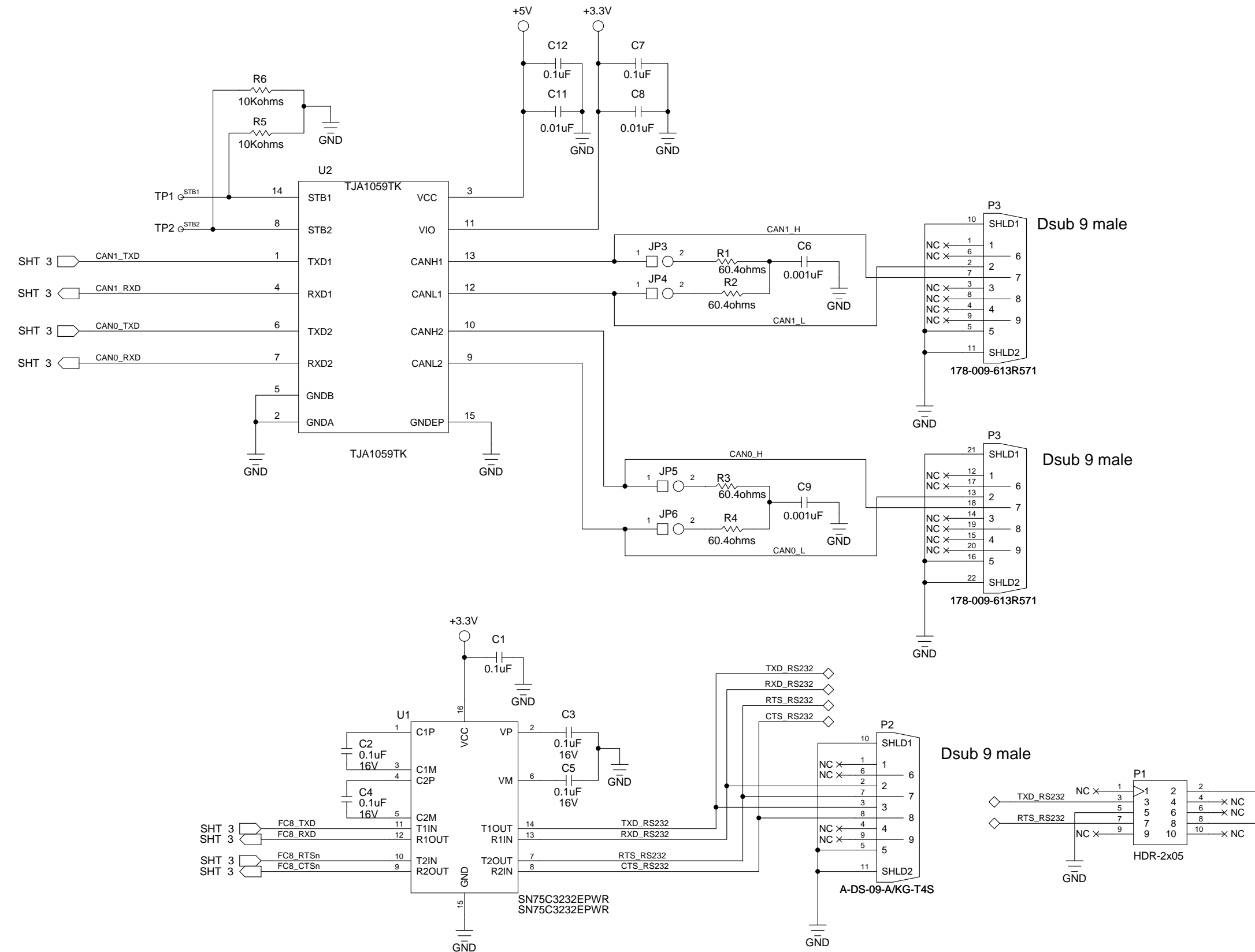

CONTRACT NO.		UART / CAN XCVRs		
APPROVALS	DATE	NXP Semiconductors 411 E. Plumeria Dr San Jose, CA 95134 www.standardics.nxp.com/microcontrollers/		
DRAWN	D. Consiglio			1/8/2017
CHECKED				
ISSUED	1/8/2017	SIZE	D	
		FSCM NO.		
		DWG. NO.	CANFD-01	
		REV	C	
		SCALE	SHEET 2 OF 03	

REVISIONS			
REV	DESCRIPTION	DATE	APPROVED

Arduino Shield receptacles R4

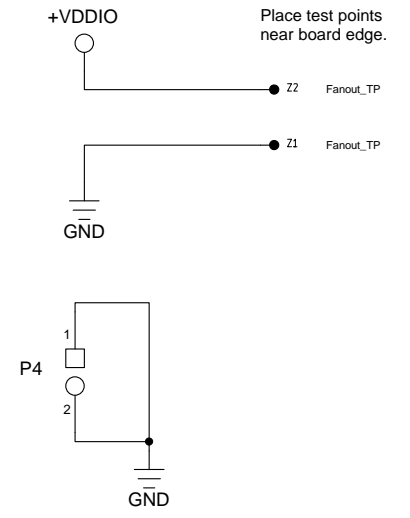
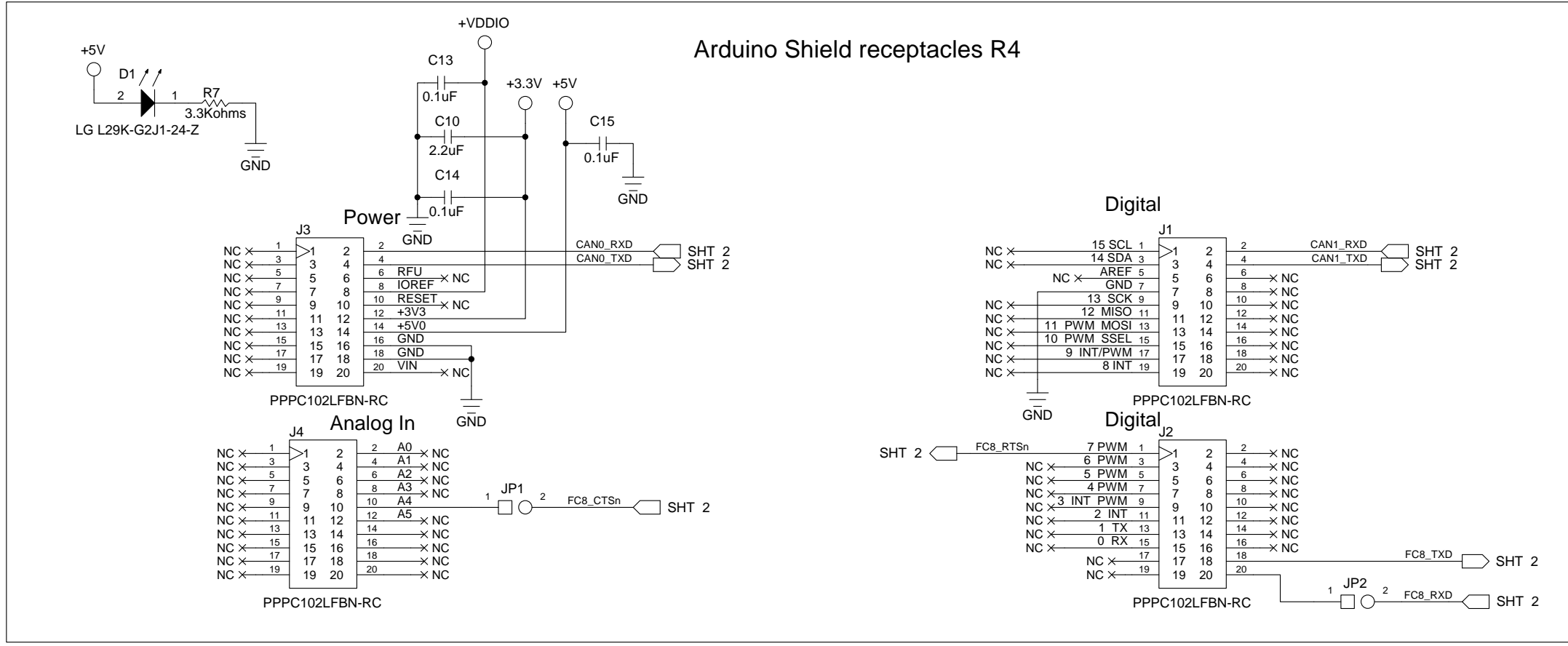

CONTRACT NO.		Xpresso / Arduino / Power supply	
APPROVALS	DATE	NXP Semiconductors 411 E. Plumeria Dr San Jose, CA 95134 www.standardics.nxp.com/microcontrollers/	
DRAWN	1/8/2017		
CHECKED	1/8/2017		
ISSUED	1/8/2017	SIZE / FSCM NO.	DWG. NO.
SCALE		CANFD-01 C	
SHEET		3 OF 03	