

MPC5675KEVB473 Evaluation Board

Table of Contents

Power Input and Regulation	Sheet 2
MPC5675K Power Pin	Sheet 3
MPC5675K GND Pin	Sheet 4
MPC5675K Miscellaneous Signals	Sheet 5
MPC5675K Analog Input	Sheet 6
MPC5675K Nexus & JTAG	Sheet 7
MPC5675K Memory Interface	Sheet 8
RESET, Boot Config, Clock	Sheet 9
LPDDR	Sheet 10
ETHERNET PHYSICAL INTERFACE	Sheet 11
CAN PHYSICAL INTERFACE	Sheet 12
LIN & SCI PHYSICAL INTERFACE	Sheet 13
FLEXRAY PHYSICAL INTERFACE	Sheet 14
User Peripherals	Sheet 15
USER CONNECTORS	Sheet 16

Revisions

Rev	Description	Date	Designer
X1	Draft	January 22, 2010	Qiao Jun
X2	Draft 2	January 29, 2010	Robertson Andrew & Qiao Jun
X3	Draft 3	February 2, 2010	Robertson Andrew & Qiao Jun
X4	Draft 4	February 6 2010	Robertson Andrew & Qiao Jun
X5	Draft 5	February 9 2010	Robertson Andrew & Qiao Jun
X6	Split ONLY for MPC5675K 473BGA	February 10 2010	Robertson Andrew & Qiao Jun
X7	reset circuitry update	February 11 2010	Robertson Andrew & Qiao Jun
X8	Various updates on pages	February 15 2010	Robertson Andrew
X9	Back annotate	February 23 2010	Qiao Jun
A	Release	February 26 2010	Qiao Jun
A1	Revise	June 20 2010	Robertson Andrew & Qiao Jun
A2	Revise	June 22 2010	Robertson Andrew & Qiao Jun
A3	Revise	June 24 2010	Robertson Andrew & Qiao Jun
B	Release	July 8 2010	Qiao Jun
B1	Revise	December 15 2010	Qiao Jun
C	Release	December 17 2010	Qiao Jun
C1	Remove socket, add mDDR	May 11 2011	Qiao Jun
C2	Revise power regulation	July 15 2011	Qiao Jun
D	Release	July 29 2011	Qiao Jun

		Microcontroller Solutions Group	
		6501 William Cannon Drive West Austin, TX 78735-8598	
This document contains information proprietary to Freescale Semiconductor and shall not be used for engineering design, procurement or manufacture in whole or in part without the express written permission of Freescale Semiconductor.			
Designer: R60321 & B23443		ICAP Classification: FCP: FIUC: X PUBI:	
Drawing Title: MPC5675KEVB473			
Drawn by: Qiao Jun		Page Title: TITLE PAGE	
Approved: Robertson Andrew	Size C	Document Number SCH-26488 PDF: SPF-26488	Rev D
Date: Tuesday, August 02, 2011		Sheet 1 of 16	

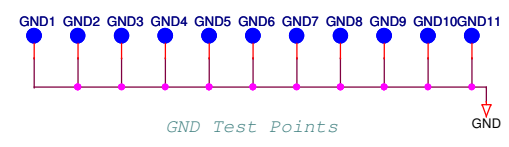
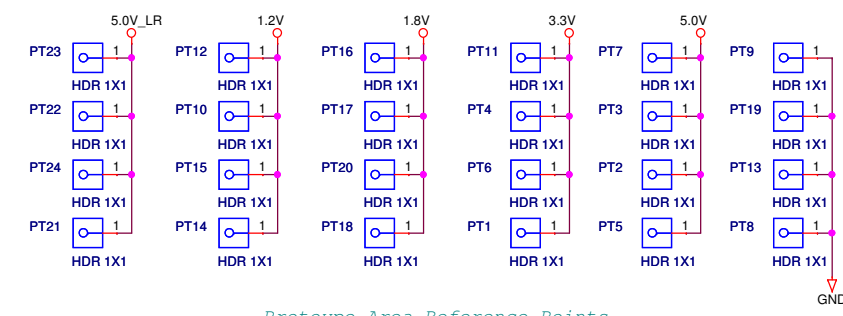
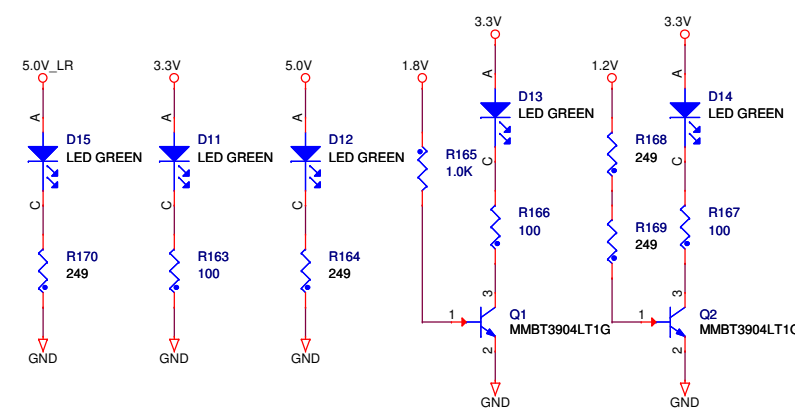
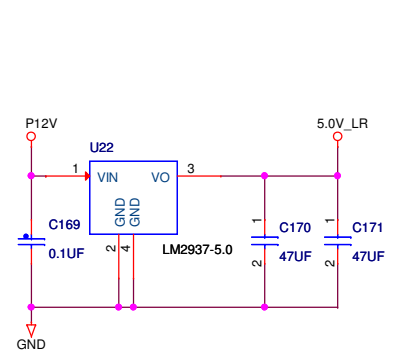
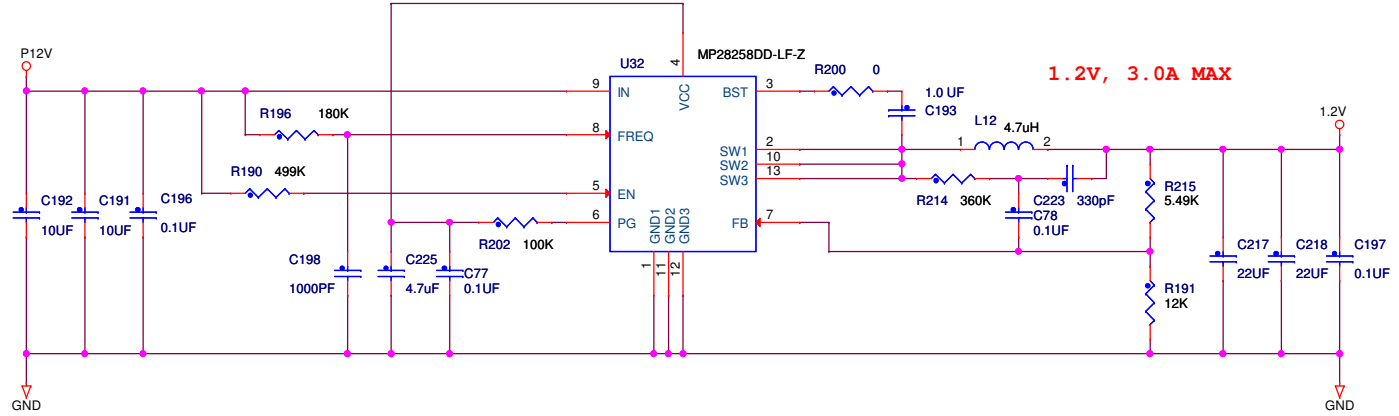
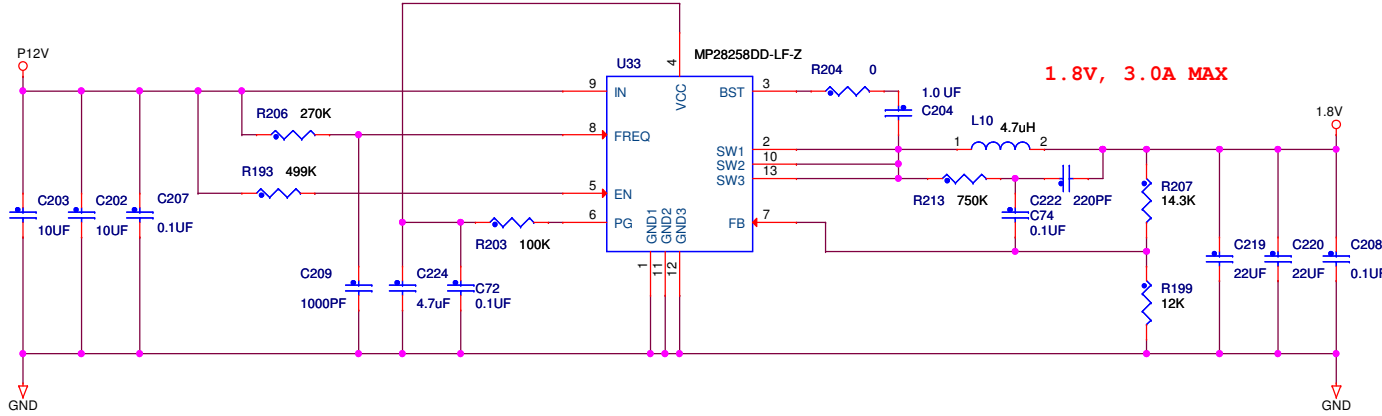
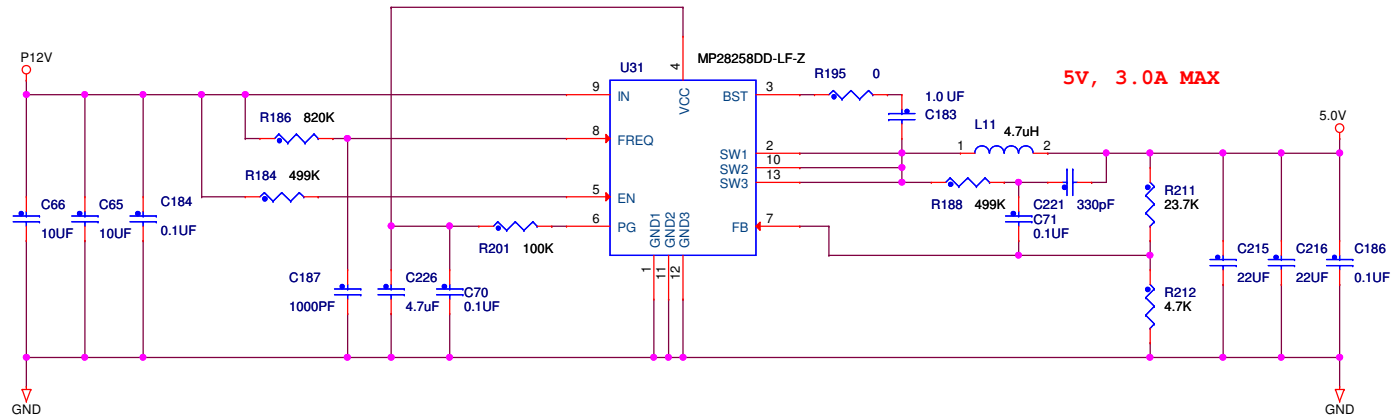
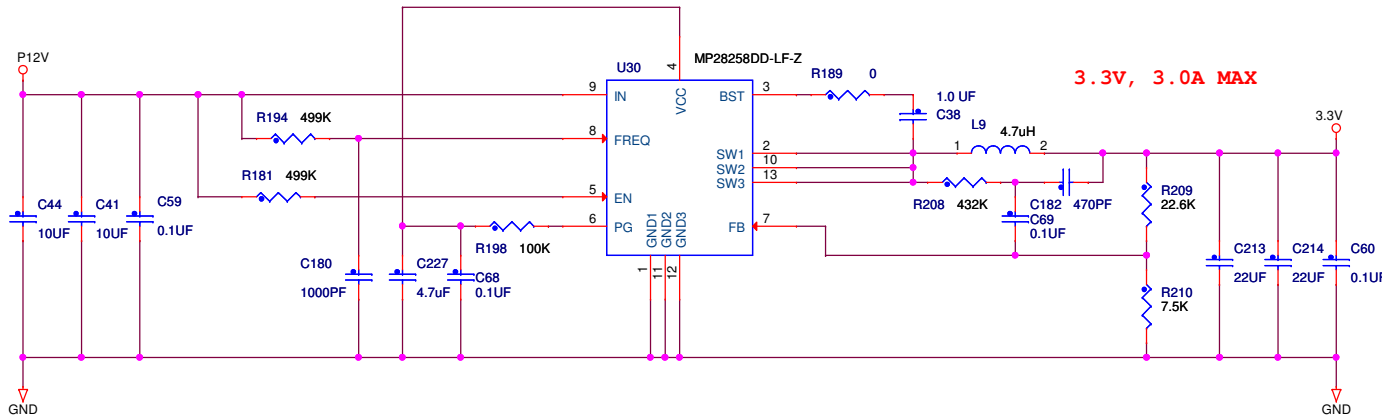
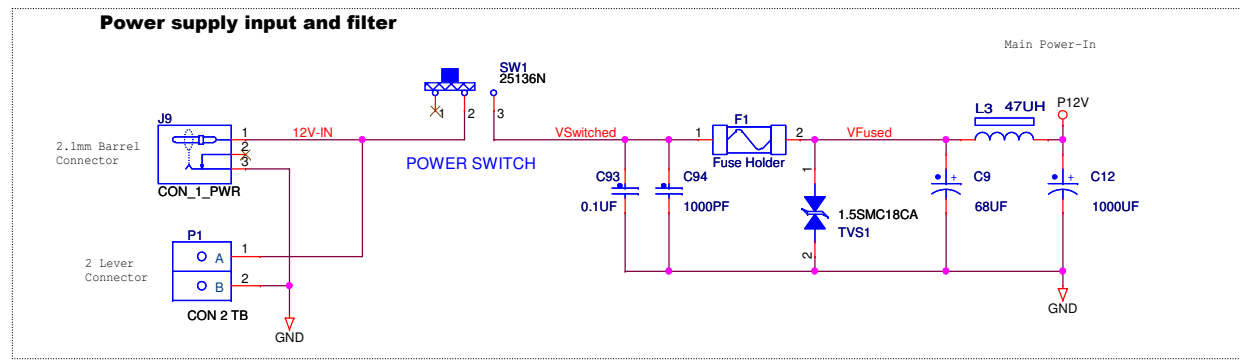

ICAP Classification: FCP: FIUO: X PUBL:

Drawing Title: **MPC5675KEVB473**

Page Title: **Power Input and Regulation**

Size C	Document Number SCH-26488 PDF: SPF-26488	Rev D
--------	--	-------

Date: Tuesday, August 02, 2011 Sheet 2 of 16

Place all caps below as close as possible to the corresponding VDD and VSS pin pair

Put as close as possible between VDD_LV_COR and VSS_LV_COR,
Ideal placement at bottom side of PCB between center ball matrix and IO ring,
Place circuitry 4 times at the centre.

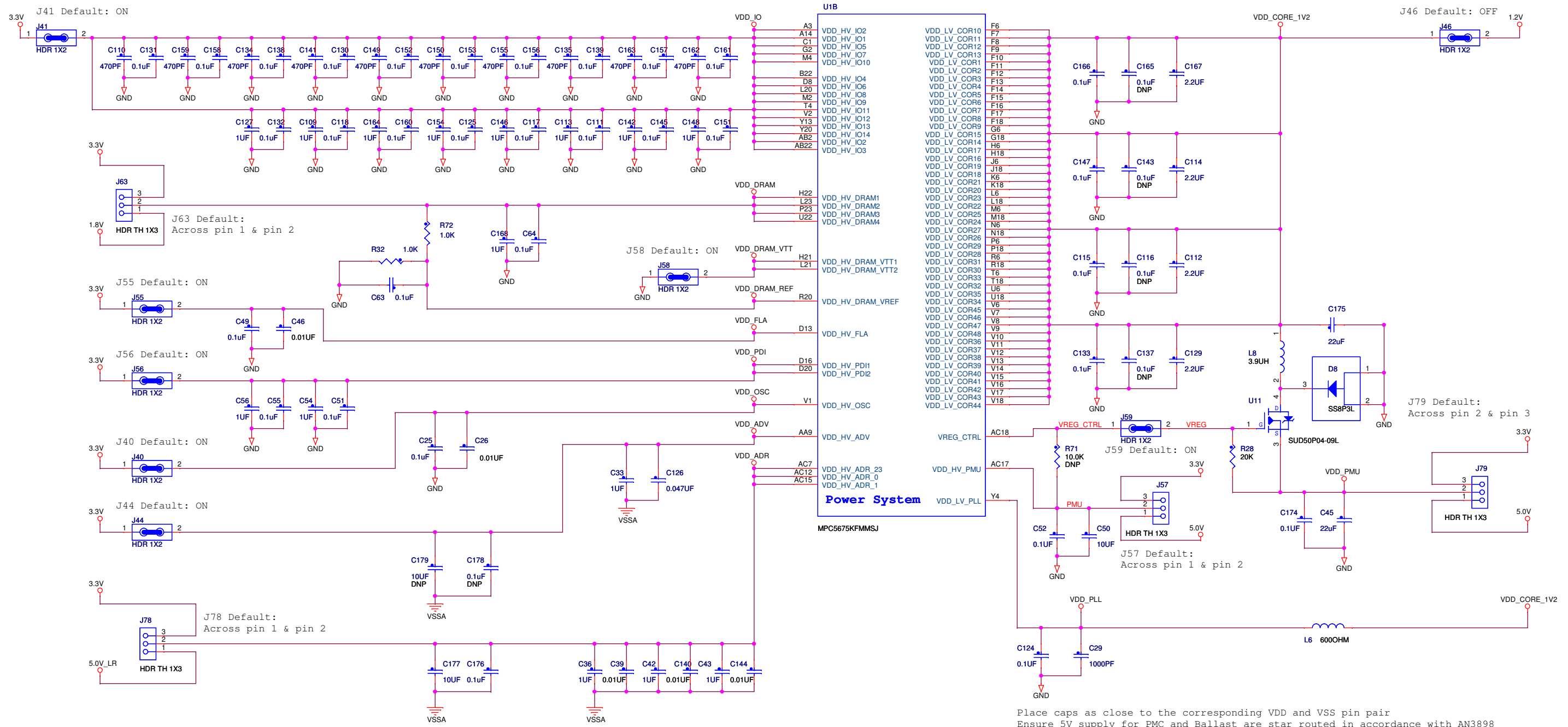

Place caps as close to the corresponding VDD and VSS pin pair
Ensure 5V supply for PMC and Ballast are star routed in accordance with AN3898

ICAP Classification: FCP: FIUC: X PUBL:		
MPC5675KEVB473		
Page Title: MPC5675K Power Pin		
Size C	Document Number SCH-26488 PDF: SPF-26488	Rev D
Date: Tuesday, August 02, 2011	Sheet 3 of 16	

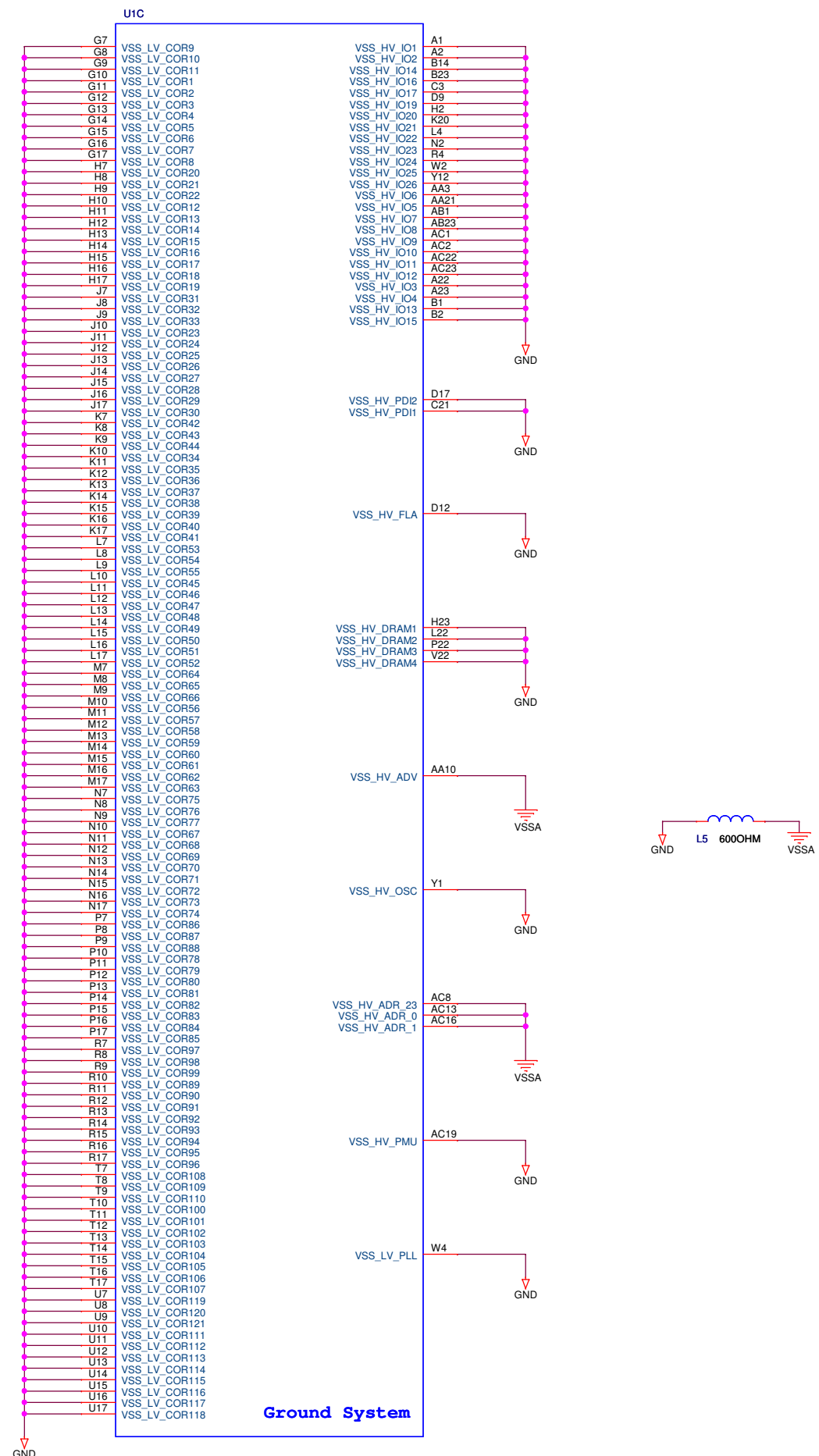

freescale
semiconductor

ICAP Classification: FCP: FIUC: X PUBI:
Drawing Title:
MPC5675KEVB473

Page Title:
MPC5675K GND Pin

Size C	Document Number SCH-26488 PDF: SPF-26488	Rev D
Date: Tuesday, August 02, 2011	Sheet 4 of 16	

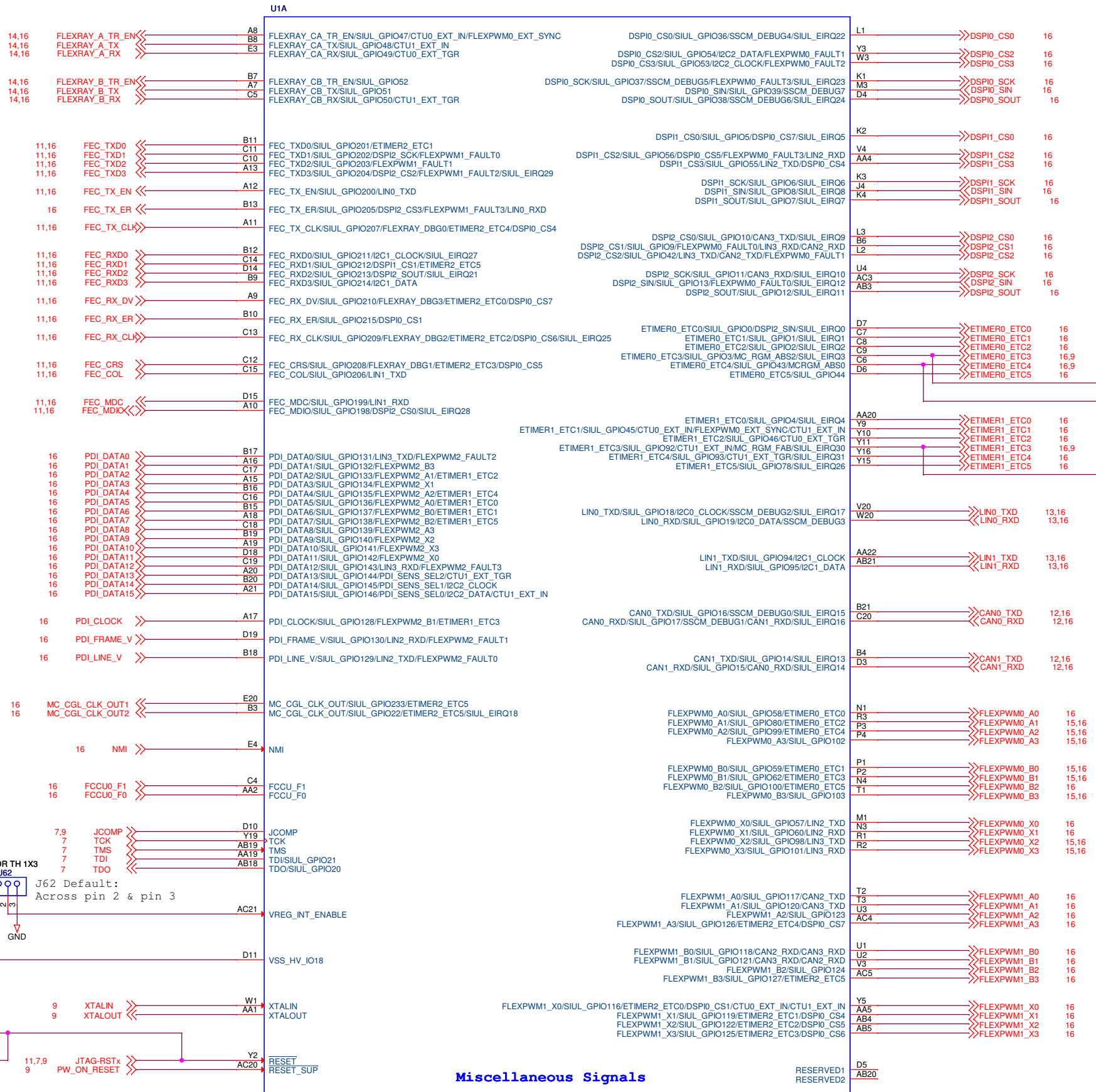

J83 Default:
Across pin 1 & pin 2

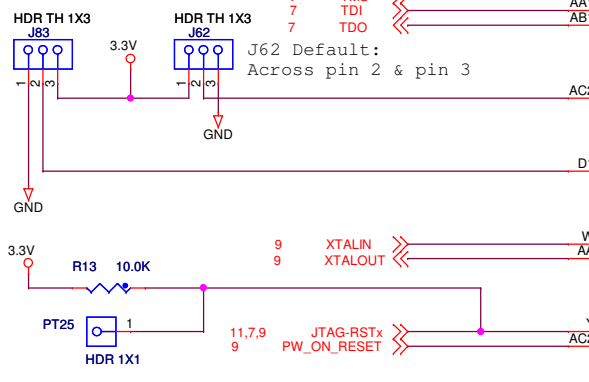

Miscellaneous Signals

freescale
semiconductor

ICAP Classification: FCP: FIUC: X PUBI:
Drawing Title:
MPC5675KEVB473

Page Title:
MPC5675K Miscellaneous Signals

Size C	Document Number SCH-26488 PDF: SPF-26488	Rev D
Date: Tuesday, August 02, 2011	Sheet 5 of 16	

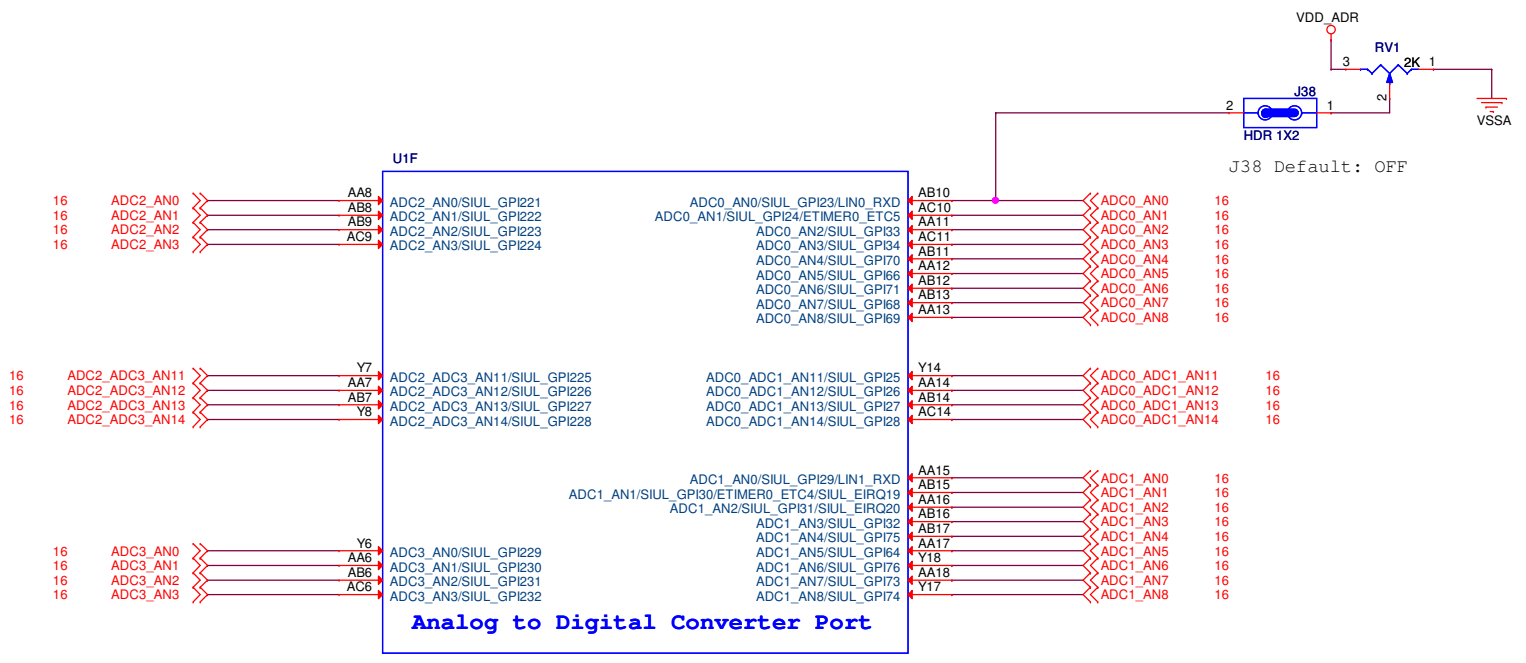

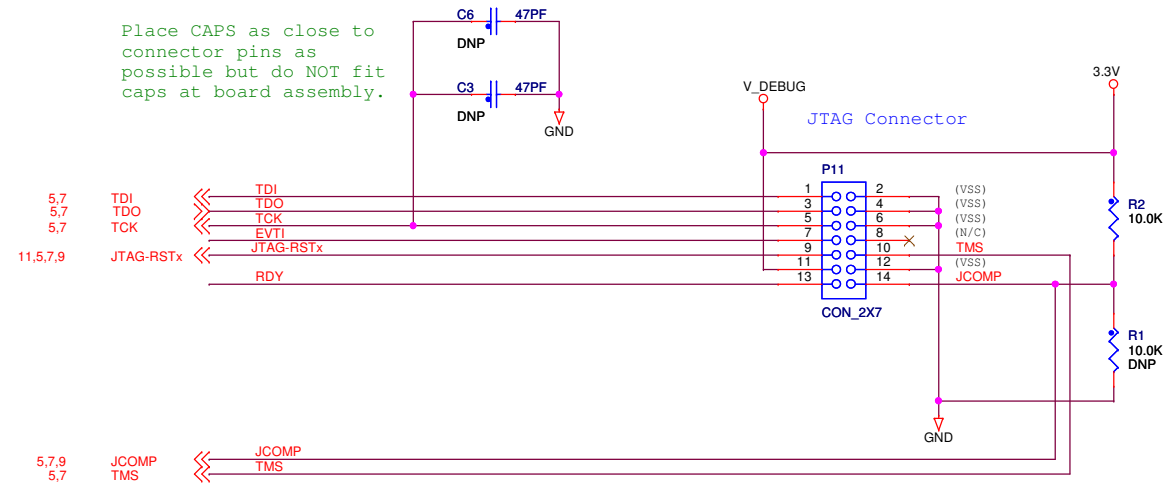
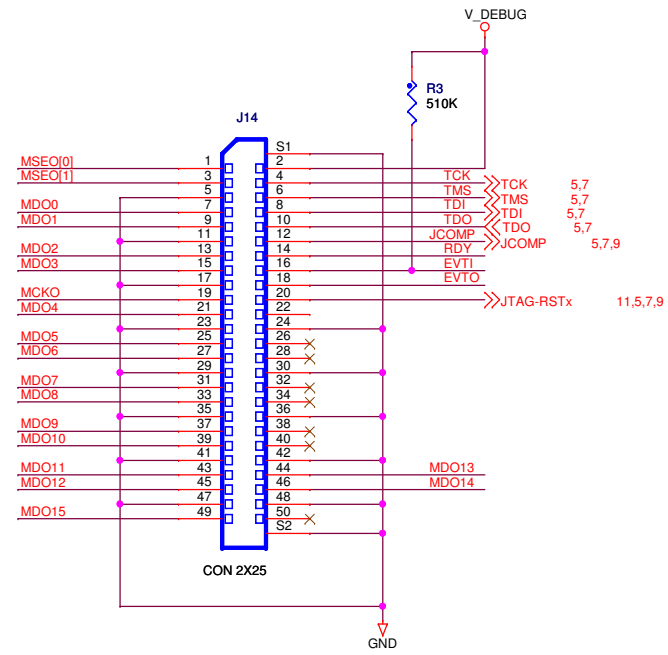
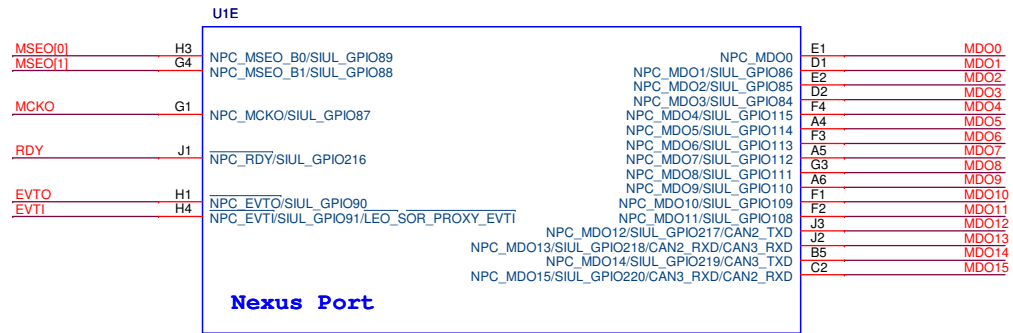

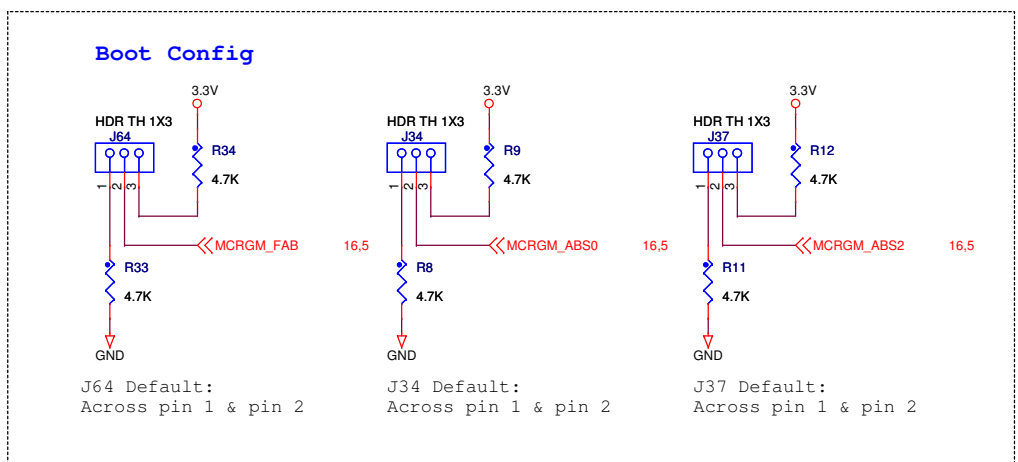
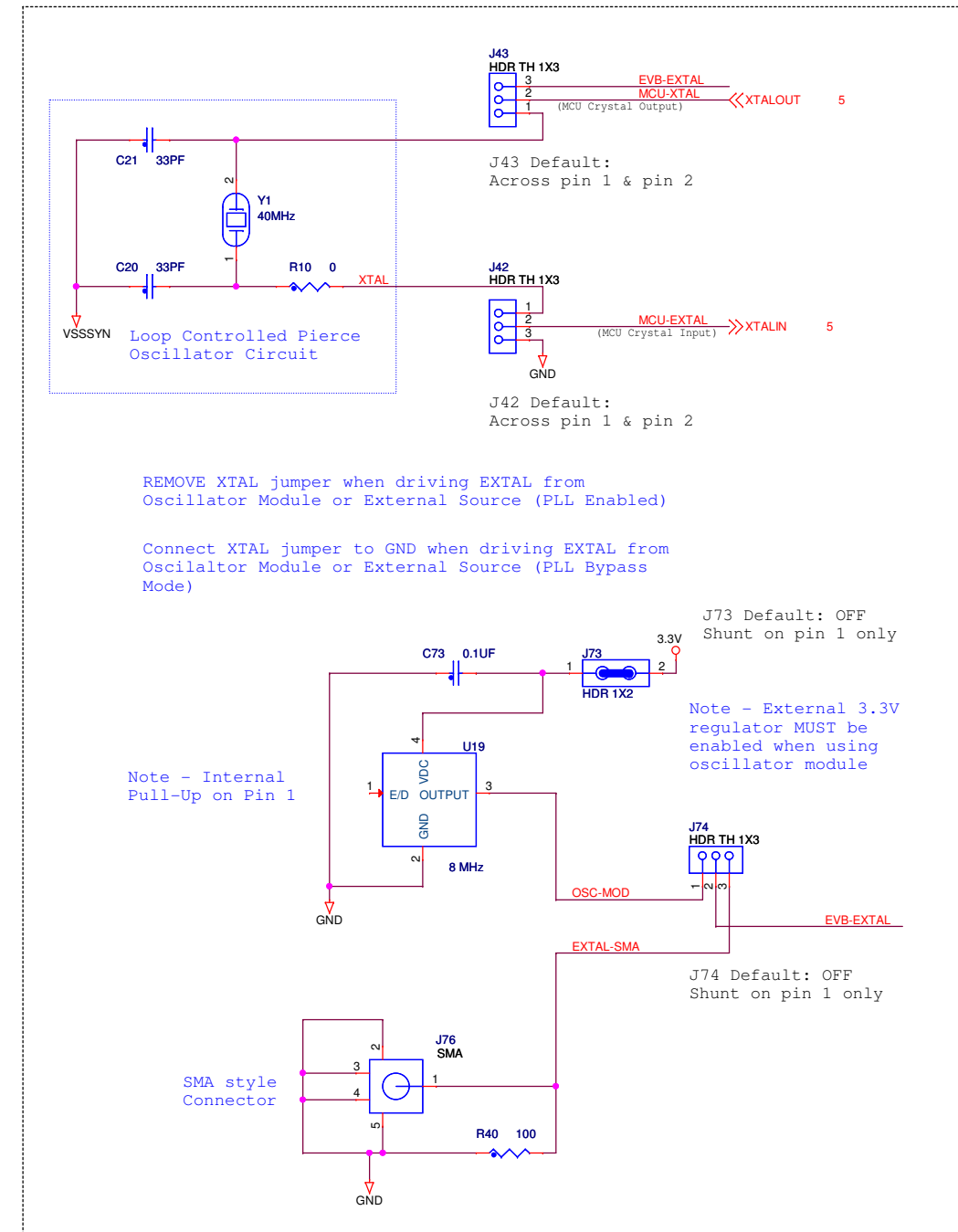
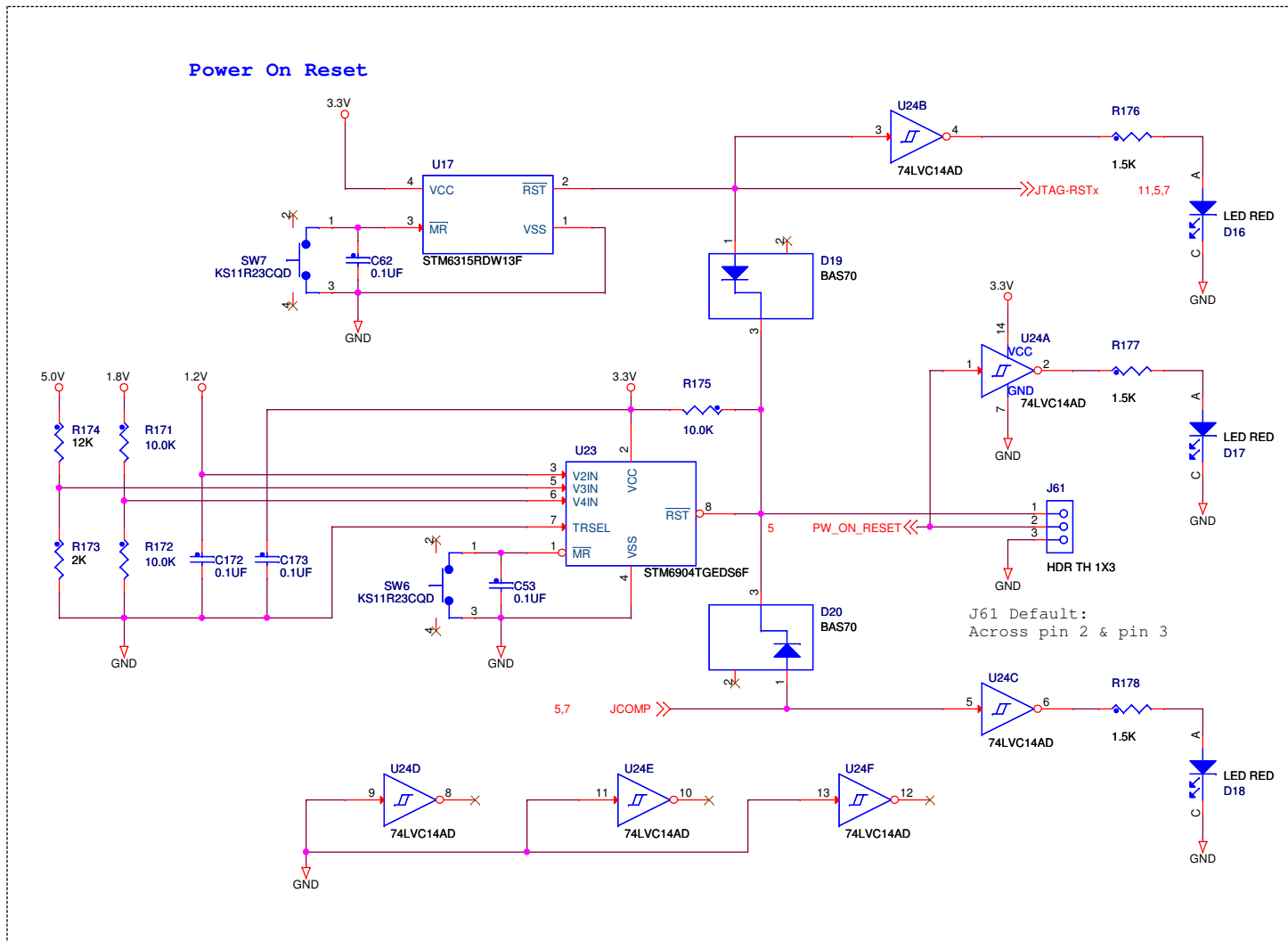

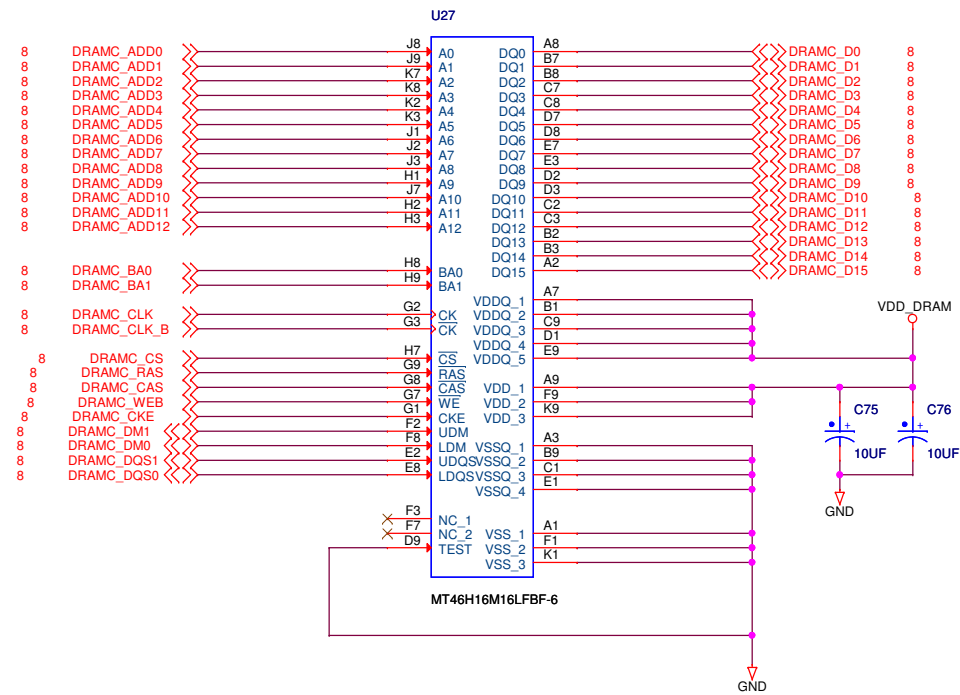

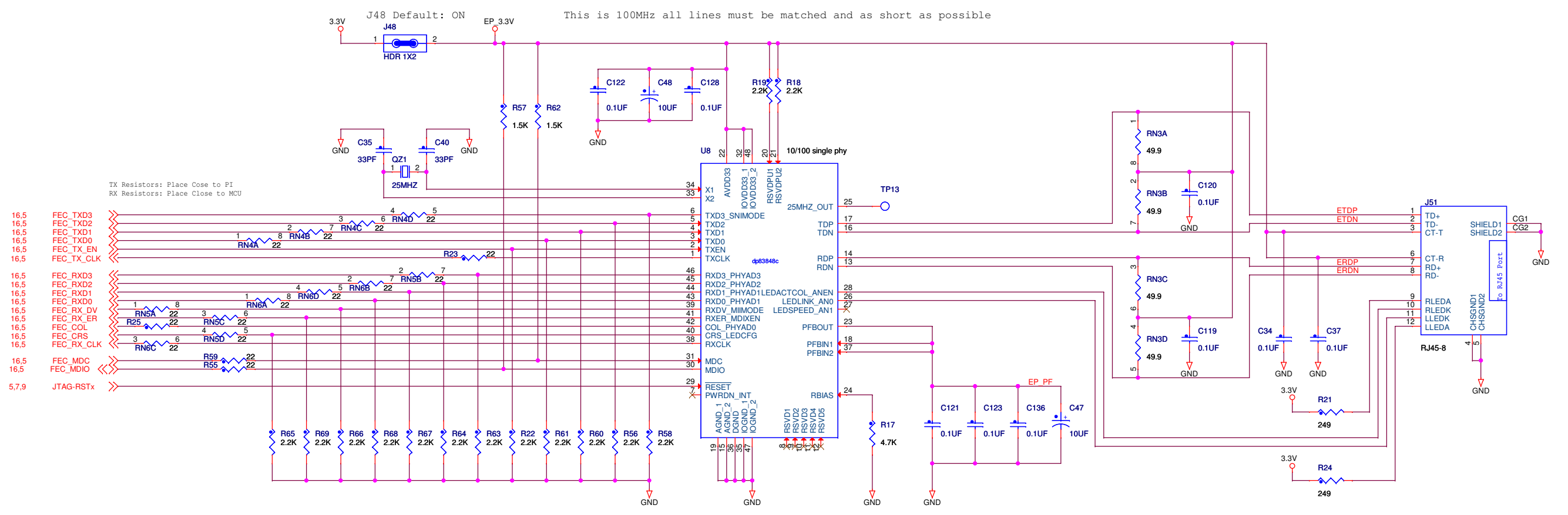

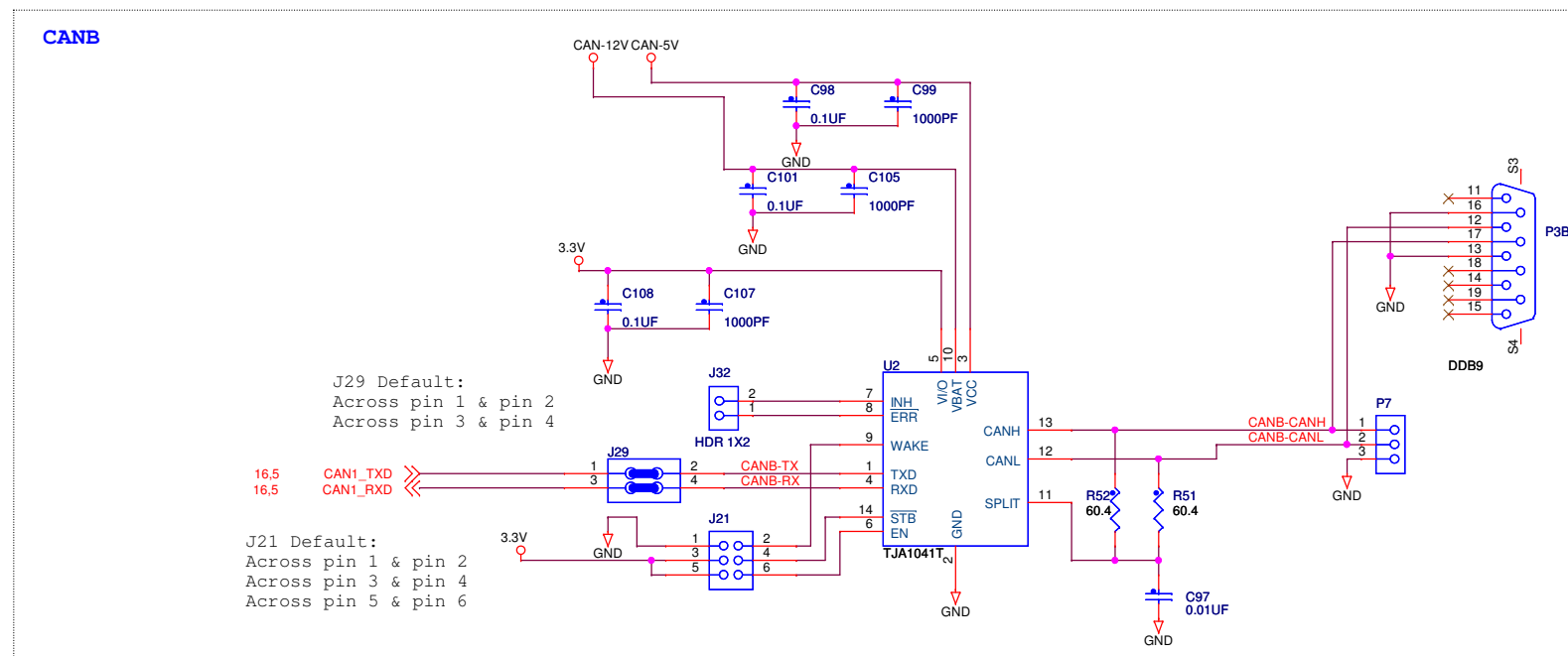
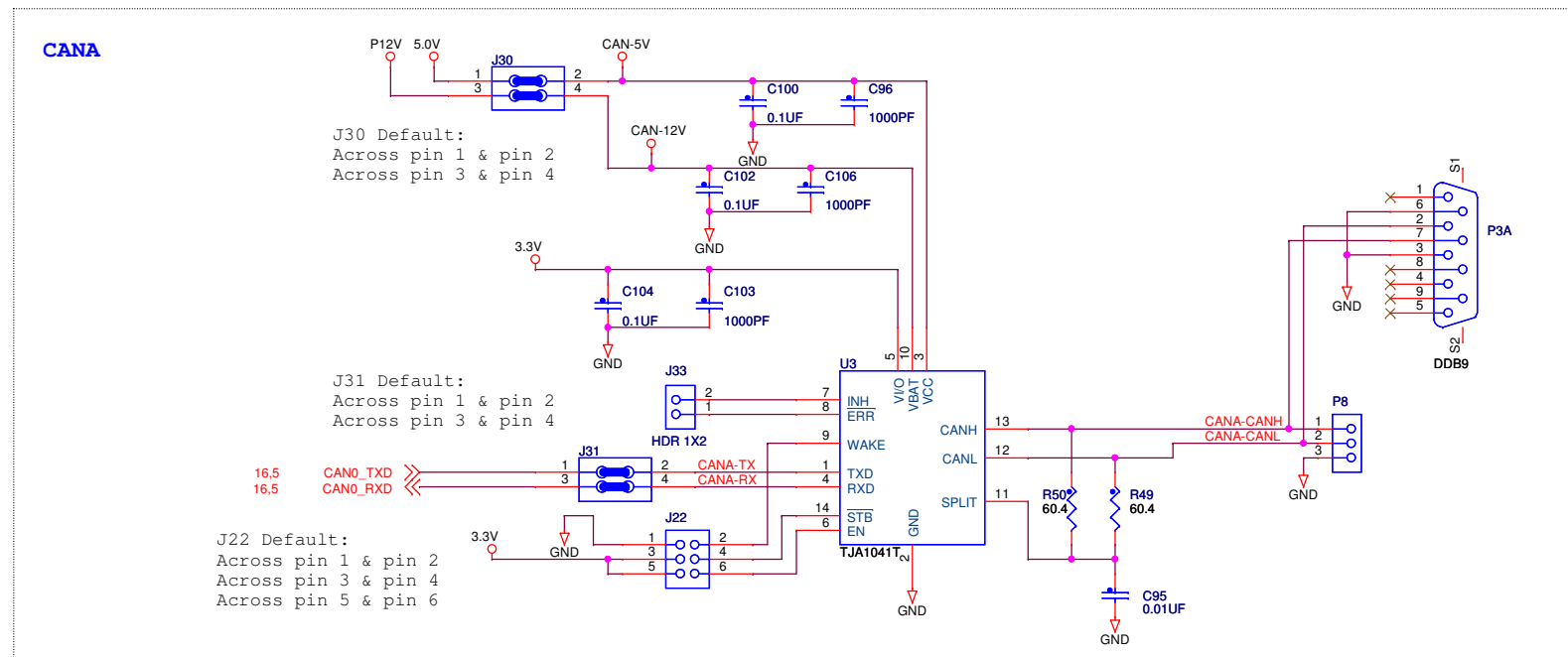

LIN

J18 Default:
Across pin 2 & pin 3

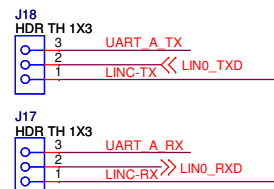

J17 Default:
Across pin 2 & pin 3

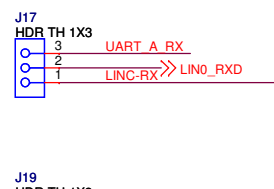

J19 Default:
Across pin 2 & pin 3

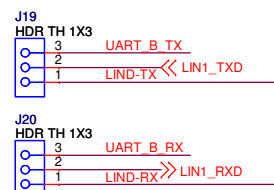

J20 Default:
Across pin 2 & pin 3

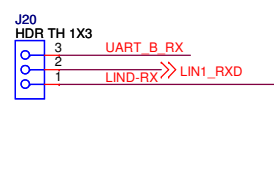

J5 Default: ON Master Mode Pullup Enable

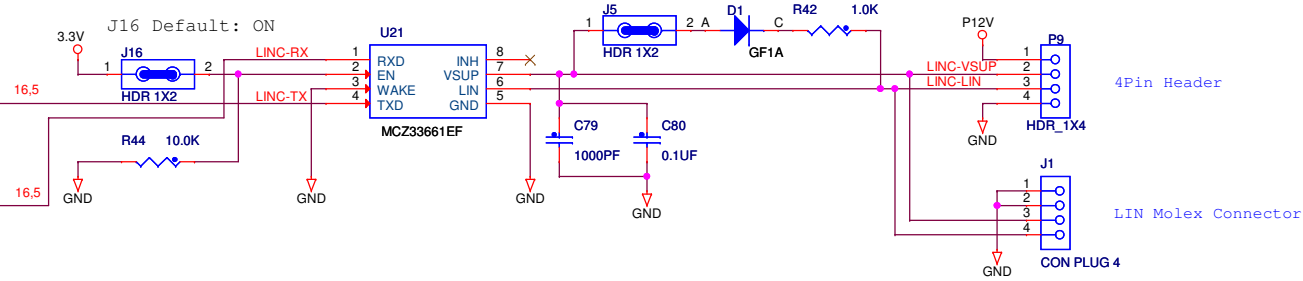

J6 Default: ON Master Mode Pullup Enable

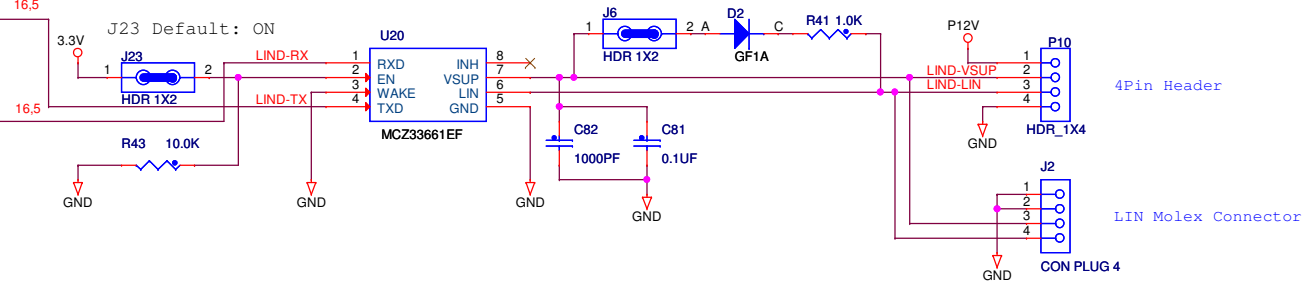

SCI

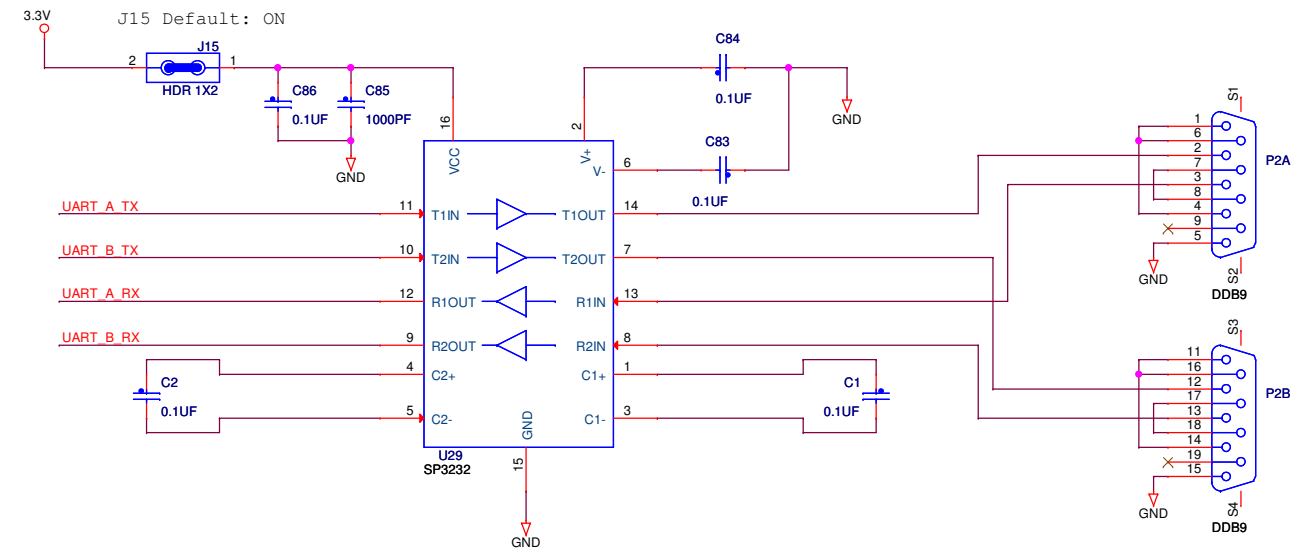

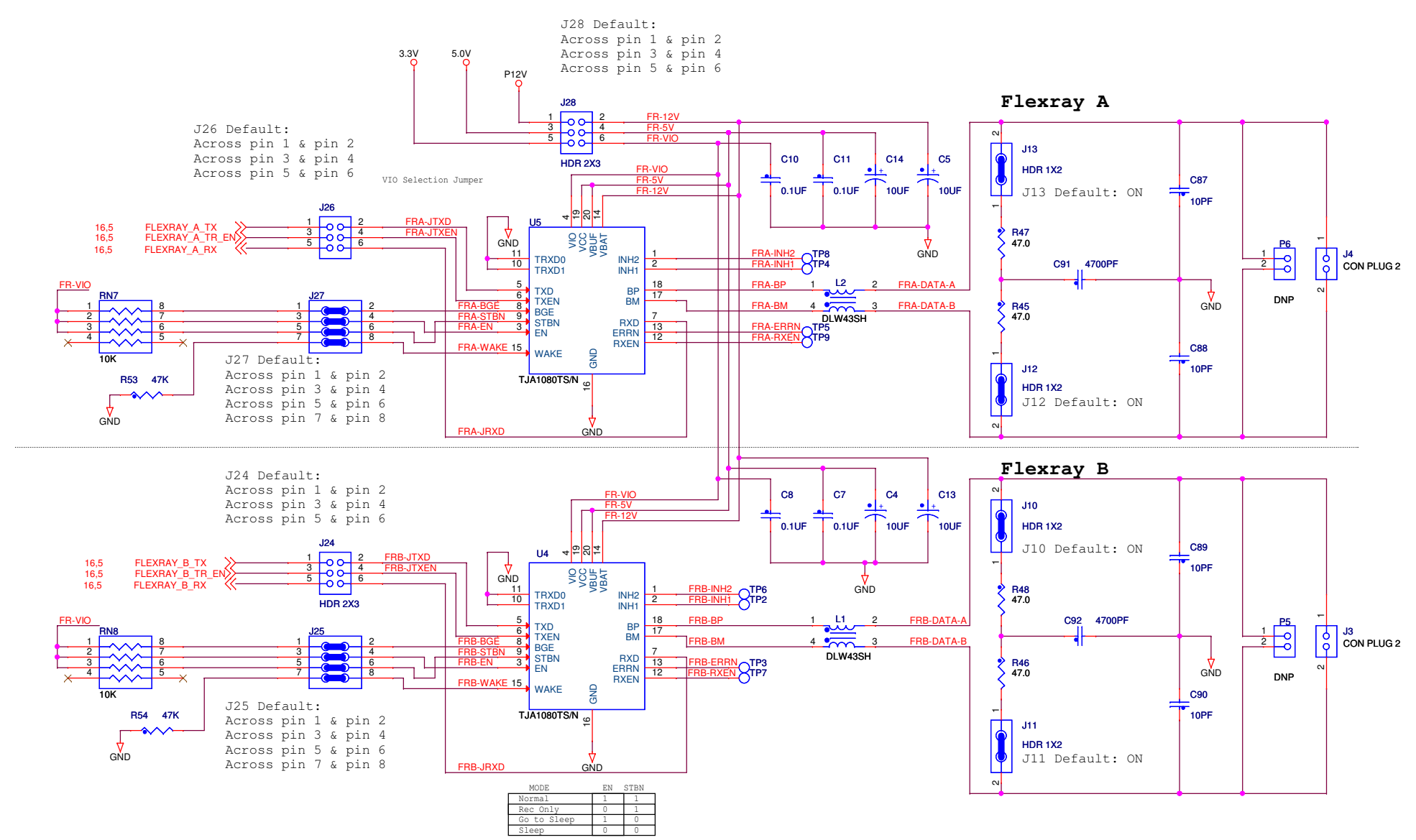

MODE	EN	STBN
Normal	1	1
Rec Only	0	1
Go to Sleep	1	0
Sleep	0	0

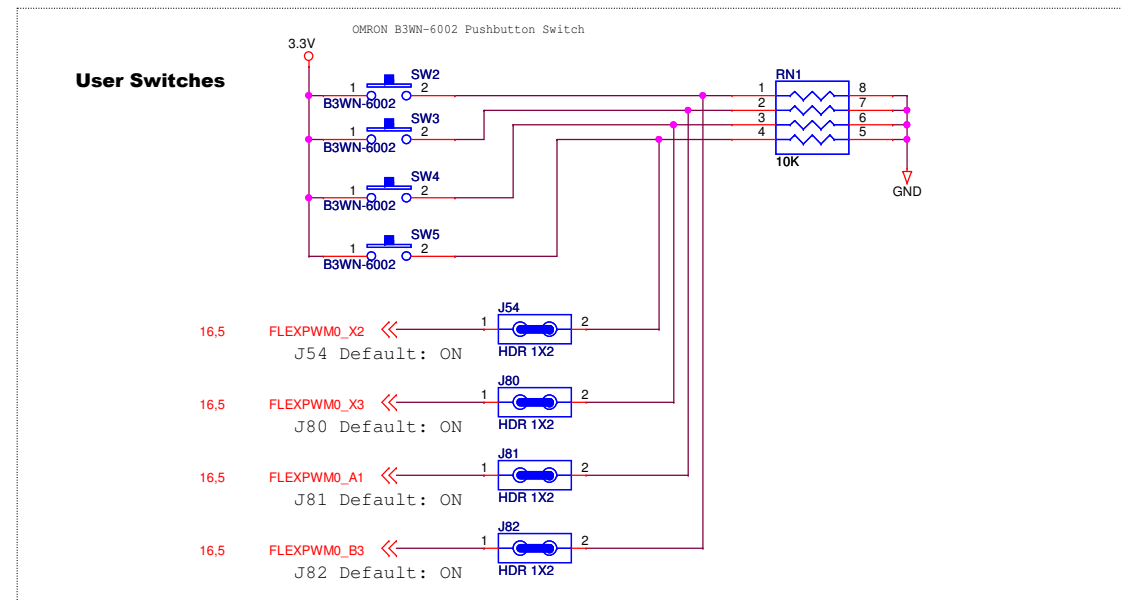
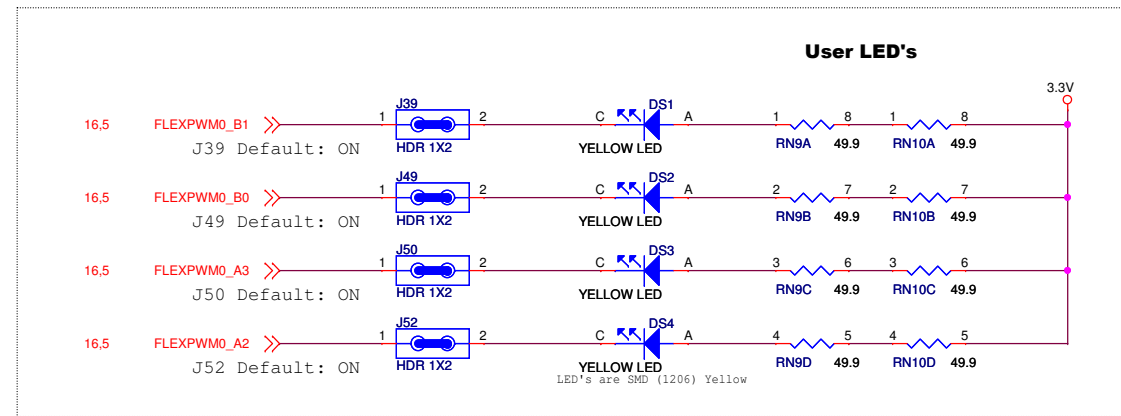

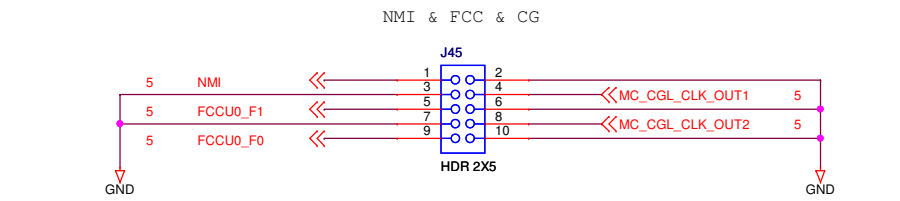
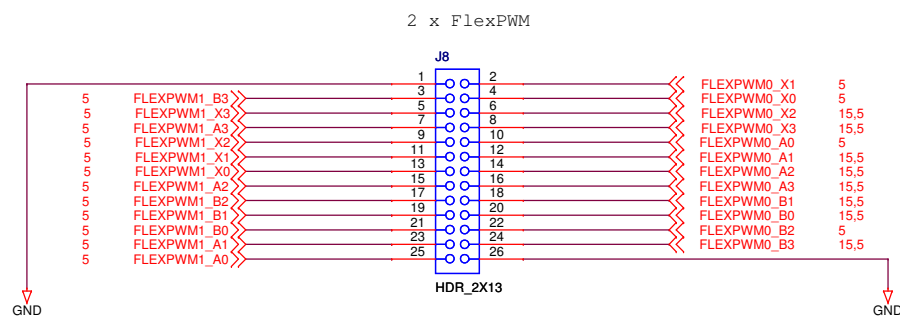
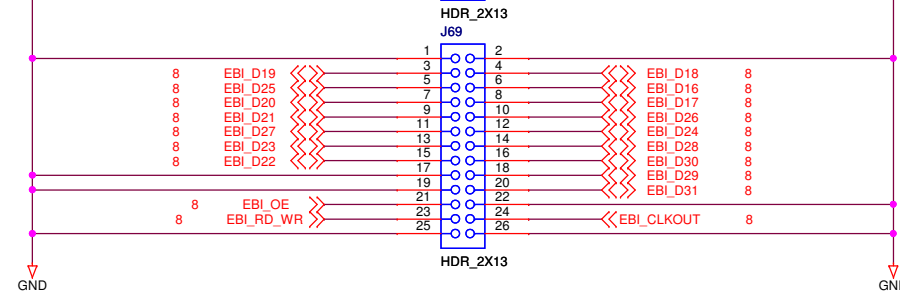
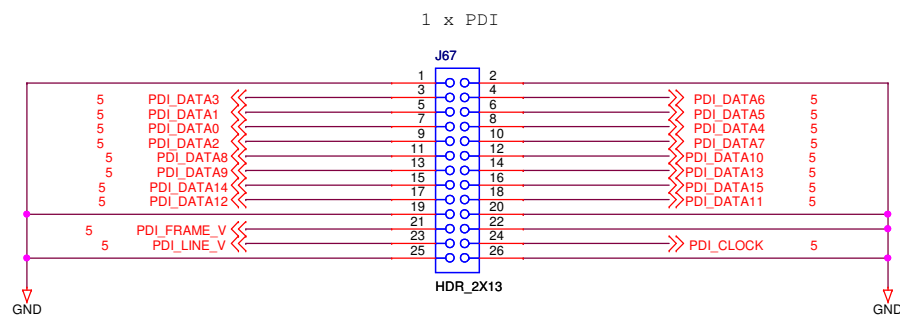
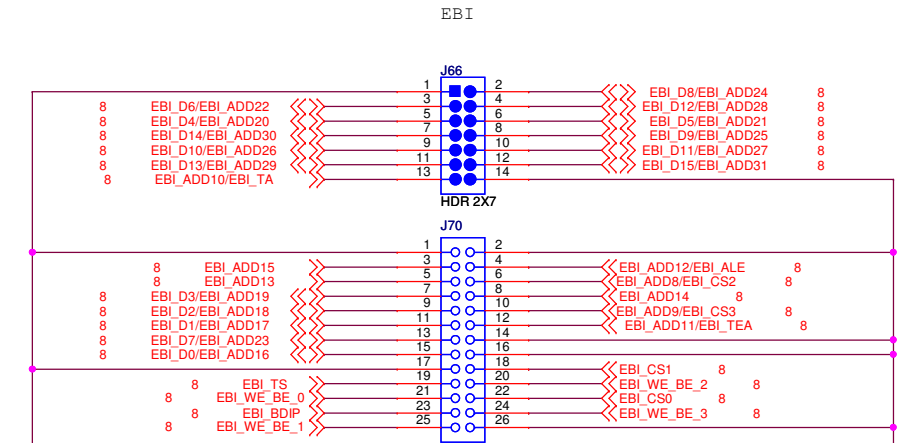
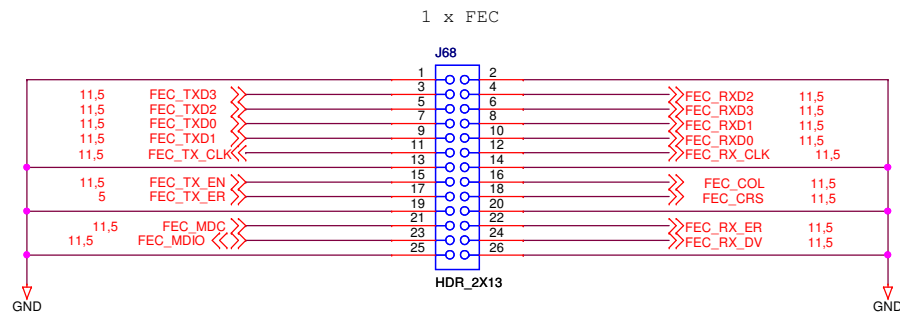
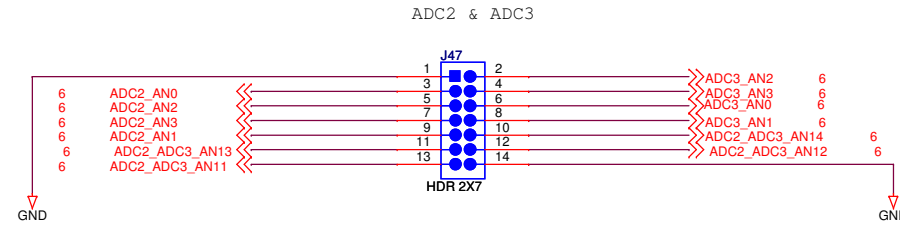
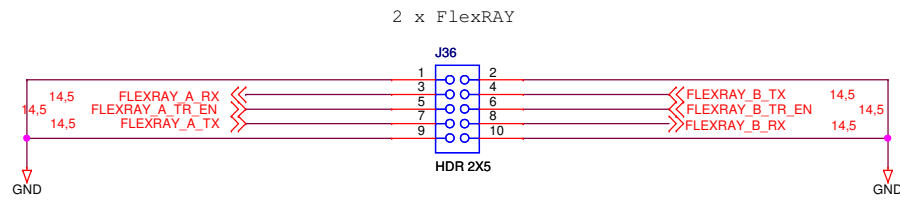
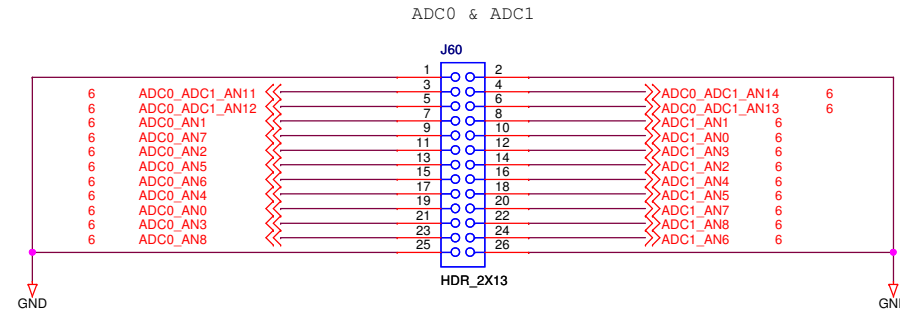
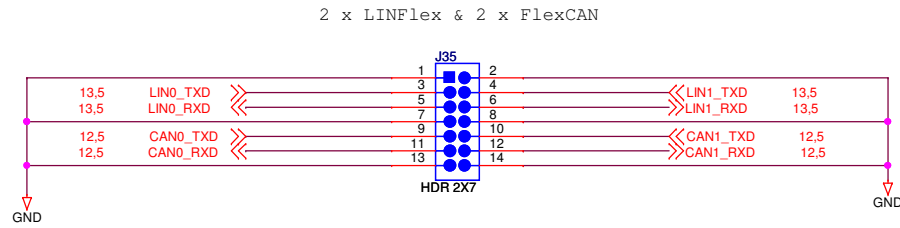
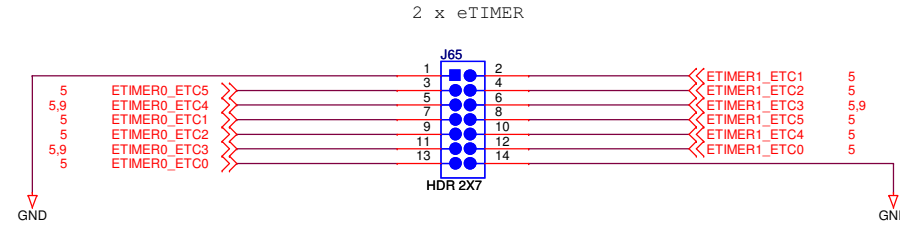
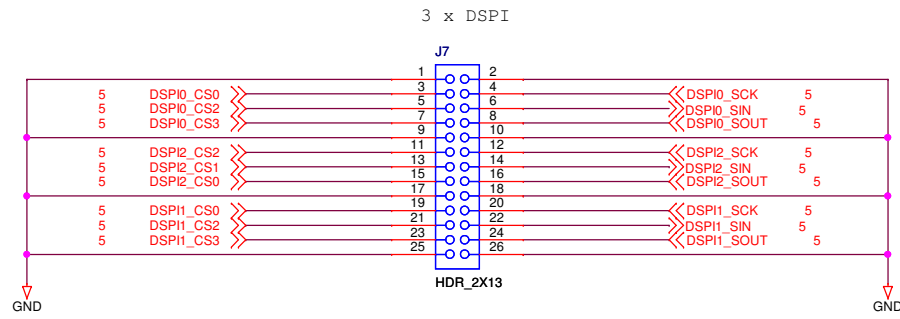

ICAP Classification: FCP: FIUC: X PUBI:

Drawing Title: **MPC5675KEVB473**

Page Title: **USER CONNECTORS**

Size C	Document Number SCH-26488 PDF: SPF-26488	Rev D
Date: Tuesday, August 02, 2011	Sheet 16 of 16	