

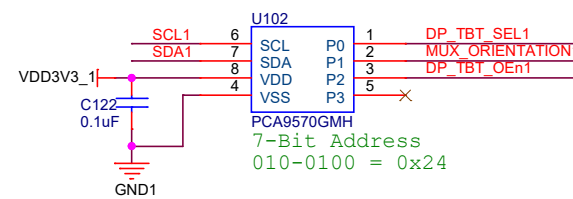

PTN38003A	R102	R103
PTN38007	DNS	DNS

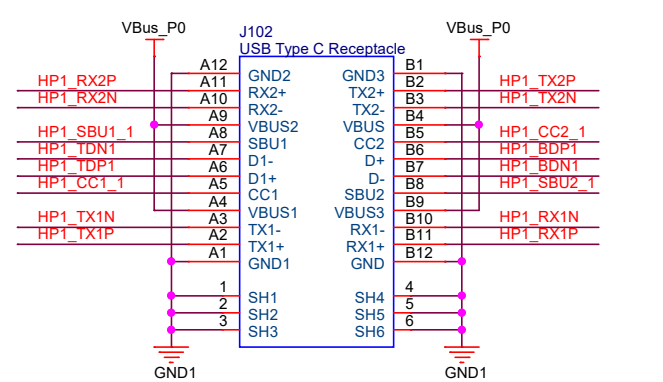

	DP_TBT_OEn	ORIENT	DP_TBT_SEL	BYTE
Safe State (Mode=0)	0	1	0	0x04
Single USB (Mode=1)	1	1	0	0x0c
JSB + DP2 (Mode=2)	0	0	0	0x00
DP4 Lane (Mode=3)	1	0	0	0x08
Thunderbolt (Mode=4)	0	0	1	0x01
JSB4 (Mode=5)	1	0	1	0x0b

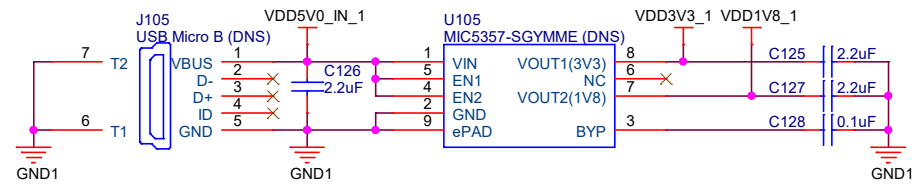
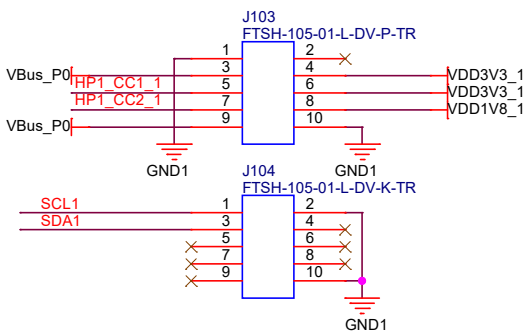
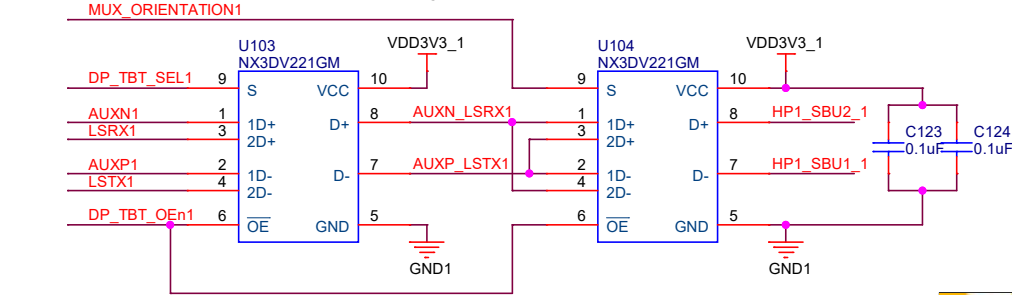



NXP Semiconductors N.V.
411 E Plumeria Drive
San Jose, CA 95134

Title		
PTN38007 DFP Configuration		
Size	Document Number	Rev
Customer	PTN38007 Plug 2 Receptacle Board	A0
Date:	Saturday, October 24, 2020	Sheet 1 of 5

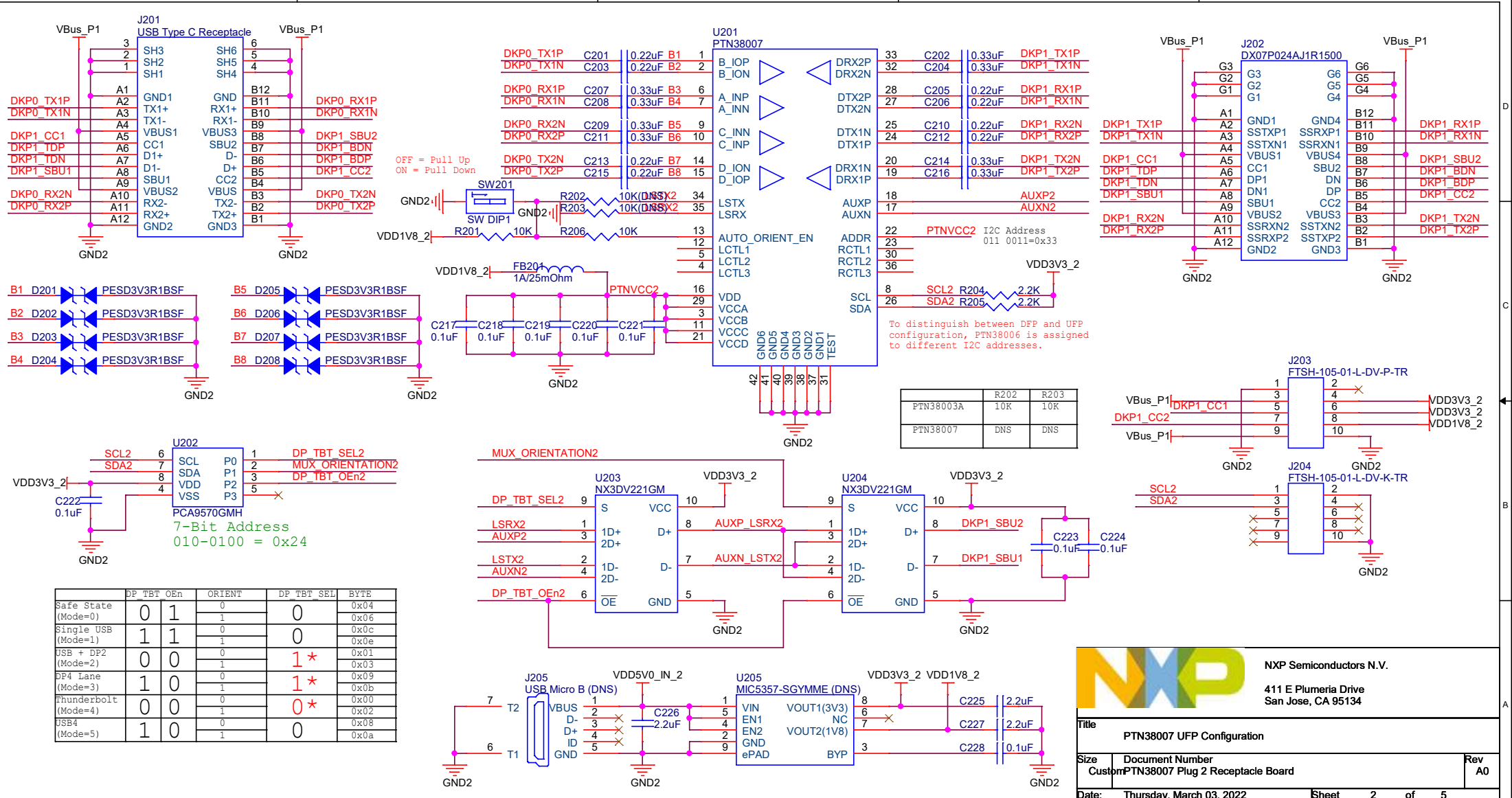

	DP TBT OEn	ORIENT	DP TBT SEL	BYTE
Safe State (Mode=0)	0	1	0	0x04
Single USB (Mode=1)	1	1	0	0x06
JSB + DP2 (Mode=2)	0	0	0	0x0c
DP4 Lane (Mode=3)	1	0	1*	0x0e
Thunderbolt (Mode=4)	0	0	0*	0x01
JSB4 (Mode=5)	1	0	1*	0x03
				0x09
				0x0b
				0x00
				0x02
				0x08
				0x0a

	R202	R203
PTN38003A	10K	10K
PTN38007	DNS	DNS

NXP Semiconductors N.V.
411 E Plumeria Drive
San Jose, CA 95134

Title
PTN38007 UFP Configuration

Size	Document Number CustomPTN38007 Plug 2 Receptacle Board	Rev A0
-------------	---	------------------

Date: Thursday, March 03, 2022 **Sheet:** 2 of 5