



FTF | **FREESCALE
TECHNOLOGY
FORUM 2015**

Introduction to **Sensor** Product Portfolio – **Sensors 101**

FTF-INS-F1223

AUG. 2015



External Use

Freescale, the Freescale logo, AltVec, C-5, CodeTEST, CodeWarrior, ColdFire, ColdFire+, C-Ware, the Energy Efficient Solutions logo, Kinetis, MagniV, mobileGT, PEG, PowerQUICC, Processor Expert, QorIQ, QorIQ Converge, Qorivva, Ready Play, SafeAssure, the SafeAssure logo, StarCore, Symphony, VortiQa, Vybrid and Xtrinsic are trademarks of Freescale Semiconductor, Inc., Reg. U.S. Pat. & Tm. Off. Airfast, BaseKit, BeeStack, CoreNet, Flexis, Layerscape, MXC, Platform in a Package, QUICC Engine, SMARTMOS, Tower, TurboLink and UMEMS are trademarks of Freescale Semiconductor, Inc. All other product or service names are the property of their respective owners. © 2015 Freescale Semiconductor, Inc.



Agenda

- Introduction and Session Overview
- Brief History and Market
- Freescale's Sensor Portfolio
 - Acceleration Sensors
 - Gyroscope
 - Magnetic Sensors
 - Pressure Sensors
 - Sensing Platforms
- Development Tools
- Session Review and Wrap-up



Introduction to Sensor Product Portfolio

During this session you will learn about Freescale's sensor portfolio, key sensor applications, and ways to help solve problems with Freescale sensors

Benefits of attending this session are:

- Greater knowledge of a strong portfolio of diverse sensor types
- Awareness of intelligent integration with the right combination of leading sensor types
- Greater value and decision making to the overall sensing solution
- Seed ingenuity of designs to find novel solutions



Introduction to Sensor Product Portfolio

- **Technology problems and solutions covered in this session framed around Intelligent Contextual Sensing:**
 - General understanding of multiple sensor inputs leveraged to perform multiple application functions
 - Perceptive intelligence of scalable products, varying levels of integration and performance
 - Awareness of customizable software that extend sensor use cases
 - Consciousness of common software platforms and common tools that shorten design time



Session Objectives

- After completing this session you will:
 - Know the Freescale Sensor portfolio
 - Be familiar with Freescale Sensor Solutions
 - Locate, acquire and begin using our dev tools



Brief History and Market



Freescal Focus

Four Product Platforms

+ Software

Focused on Growth Markets



Automotive



Networking



Industrial



Consumer

Leveraging Three Growth Trends



The Net Effect



Health & Safety



Going Green

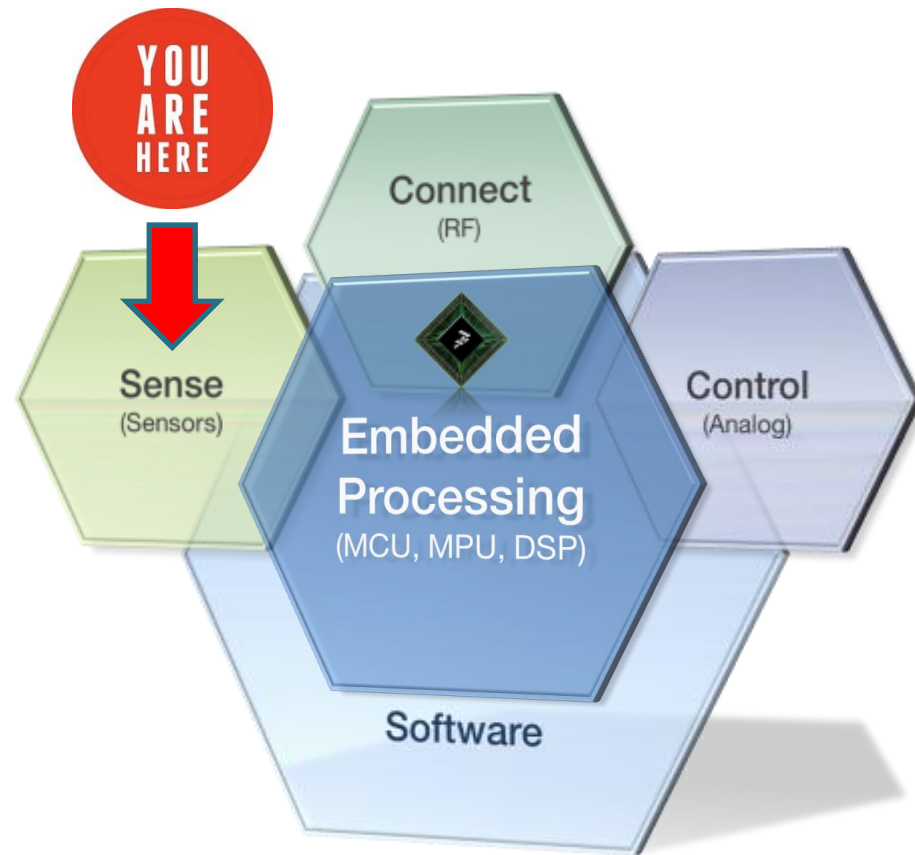

Sensors Are More Pervasive Than You Might Think – Just Check Your Pocket...

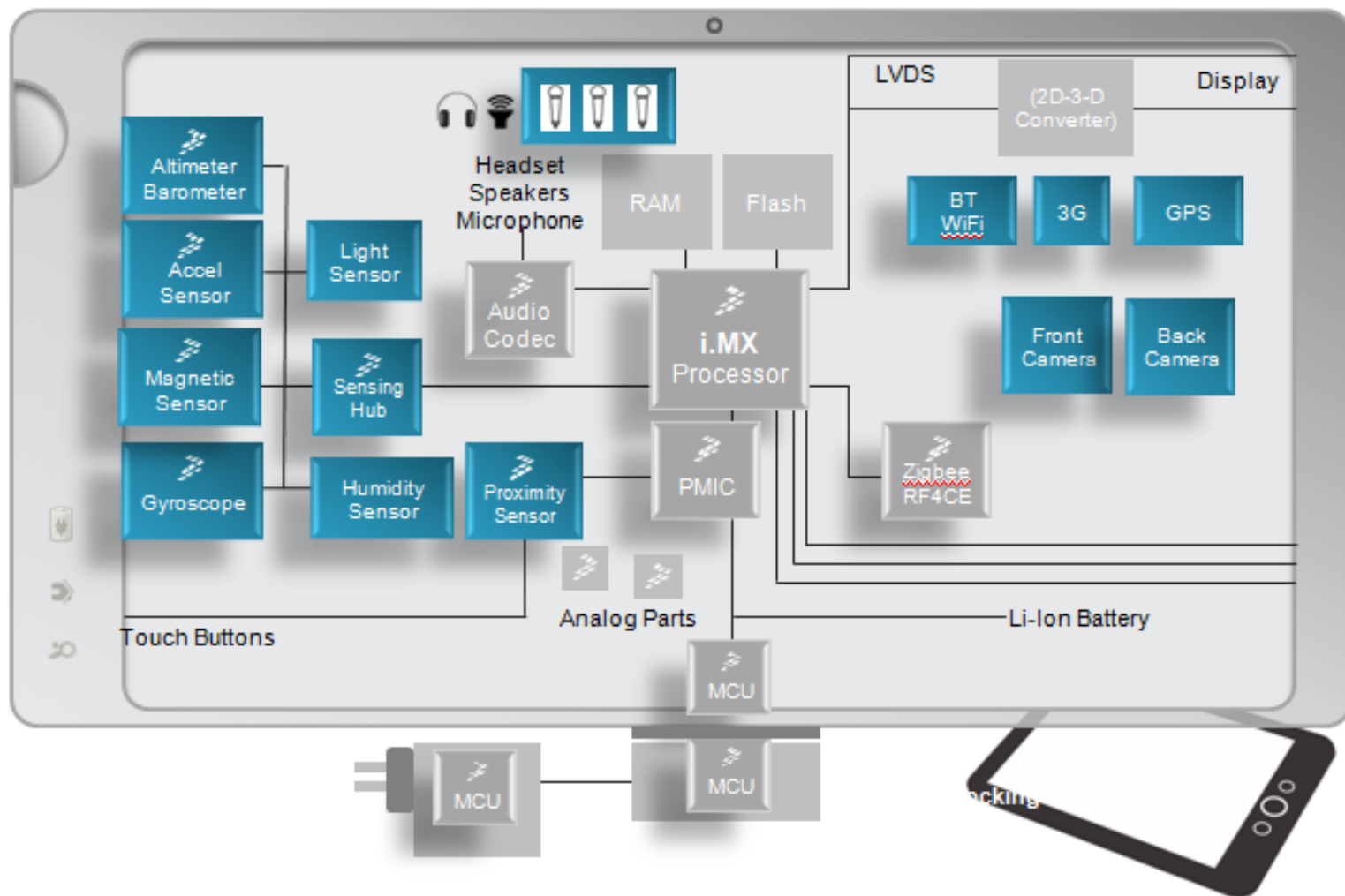

Driving Market Trends

- Proliferation of **connected intelligence**
- **Safe** and **intelligent automation**
- **Energy efficiency** and **resource conservation**
- **Quantified lifestyles**
- **Contextual awareness** and **intuitive human interface**

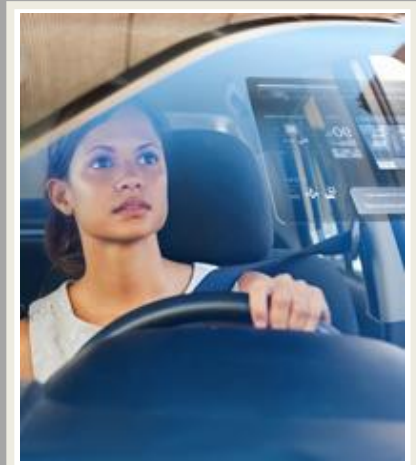

The Internet of Things is Driving Explosive Growth In Connected Devices

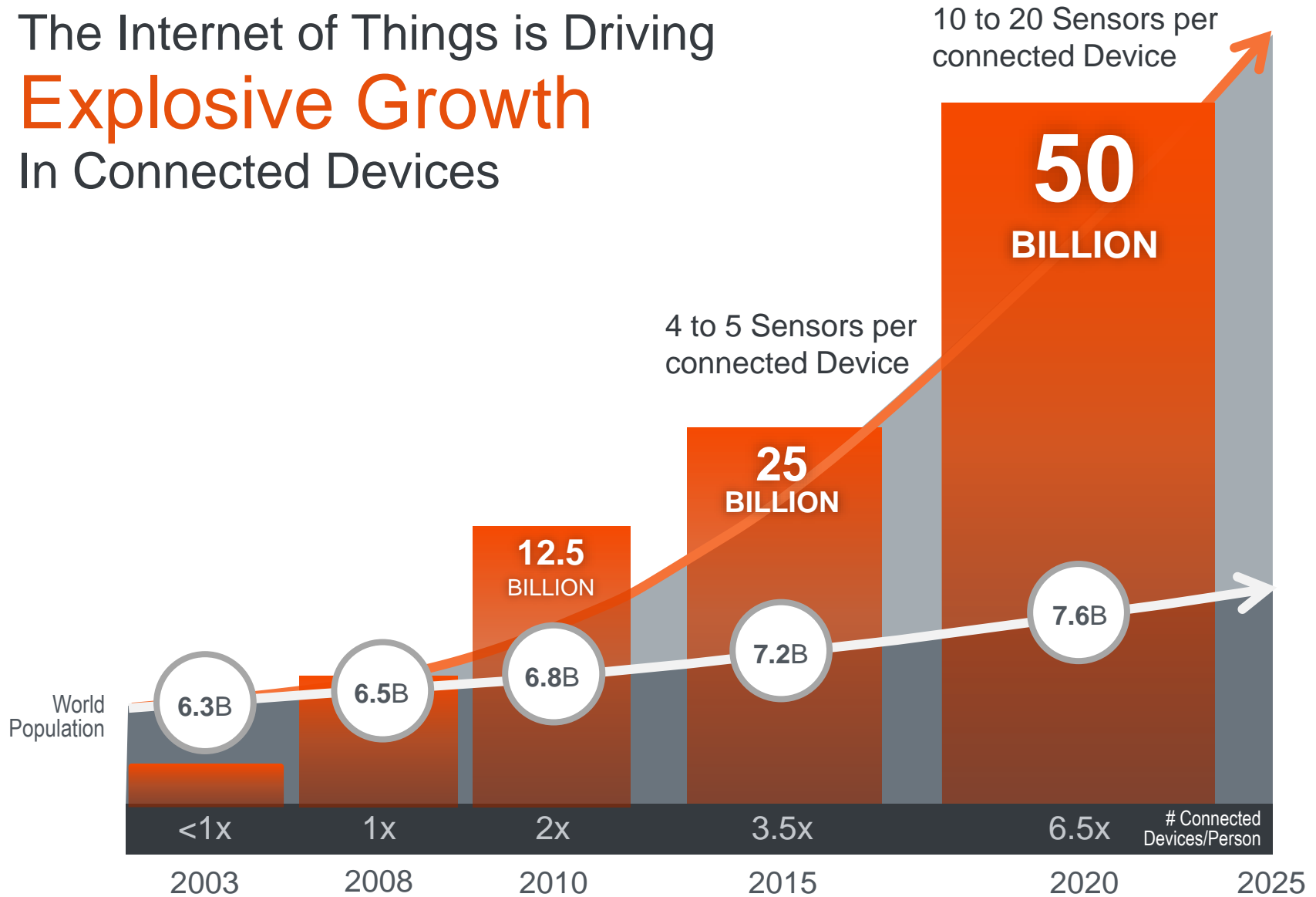

Freescale's Sensor Portfolio

MicroElectroMechanical Systems or MEMS

eCompass



Magnetometers

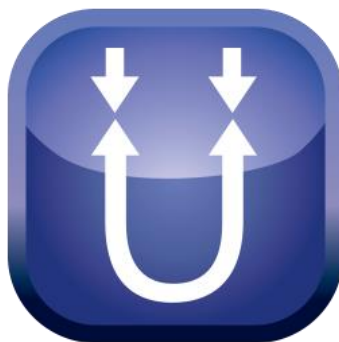

Accelerometers



Touch Sensors

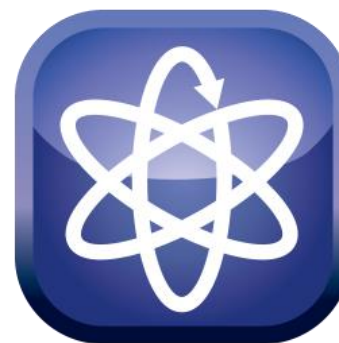

Gyro

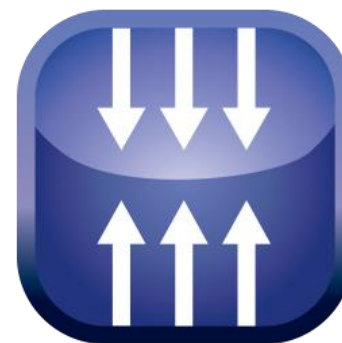

Altimeter / Pressure

Freescalé's Sensor Portfolio: Accelerometers



Sensor Type: Accelerometers

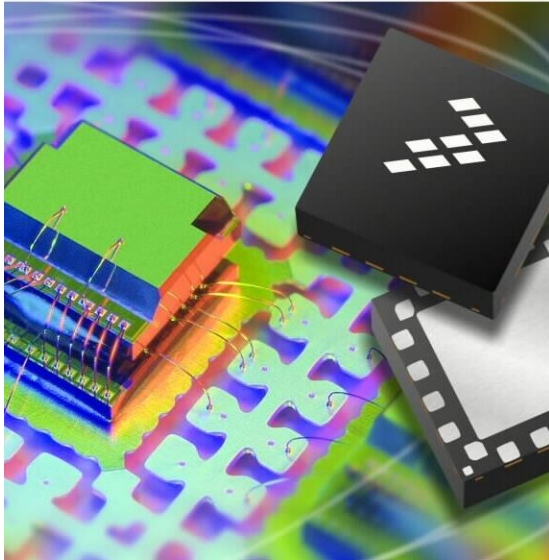

- Freescale's acceleration sensors detect changes in force resulting from tilt, motion, positioning, shock, and vibration
- Capable of single, dual, or triple axis sensing capability with range from 1.5 g to 250 g
- Devices are system-in-a-package (two chip) solutions comprised of:
 - g-cell: surface micro-electromechanical systems (MEMS) capacitive sensing cells modeled as a set of beams attached to a central mass that moves between fixed beams
 - Control IC: measures g-cell capacitance and extracts acceleration data, provides amplification, signal conditioning, low pass filtering and temperature compensation





Accelerometers: Key Products

	Sample	Production	Applications
<p>MMA8451/52/53 3-axis $\pm 2, \pm 4, \pm 8$ g 10/12/14-bit Digital I²C</p> <ul style="list-style-type: none"> • Embedded function and interrupt : (FIFO, High pass filter, P/L,...) • Ultra low noise ($99 \mu\text{g}/\sqrt{\text{Hz}}$), low TCO ($0.15\text{mg}/^\circ\text{C}$) • High performance Consumer & Industrial • Down to $0.25\text{mg}/\text{LSB}$ sensitivity • 1.95...3.6 Volt, 3 x 3 x 1 mm QFN 	Now	Now	Tilt Measurement Pedometer Power Management eCompass Asset Tracking Activity Monitor Sports Watch Fleet Management Remote Controls Appliance
<p>FXLS8471 3-axis $\pm 2, \pm 4, \pm 8$ g 14-bit Digital SPI</p> <ul style="list-style-type: none"> • Embedded functions and interrupts (all + Vector magnitude) • High performance industrial grade • 1.95...3.6 Volt, 3 x 3 x 1 mm QFN 	Now	Now	
<p>MMA845xQ</p> 			
<p>MMA8652/53 3-axis $\pm 2, \pm 4, \pm 8$ g 10/12-bit Digital I²C</p> <ul style="list-style-type: none"> • Embedded functions and interrupts (8652 same as MMA8451) • Software compatible with the MMA845x family • Low cost • 1.95...3.6 Volt, 2 x 2 mm DFN 	Now	Now	
<p>MMA865xPC</p> 			
<p>MMA8491 3-axis Tilt Sensor 14-bit Digital I²C + 3 Logic Out</p> <ul style="list-style-type: none"> • Ultra low power down to 400 nA/hz, • 3 logic outputs to flag tilt on the 3 axis • I²C interface to read raw acceleration data • 1.95...3.6 Volt, 3 x 3 x 1 mm DFN 	Now	Now	Tamper Sensor Rolling Ball Switch Alarm/Security Frefall Detect Remote Control Low Power Wake-up





Accelerometers: Key Products

	Sample	Production	Applications
FXLN8361 3-axis $\pm 2/\pm 8$ g Analog Out, low bandwidth	Now	Now	Vibration Monitoring High Precision Industrial Control Sport Applications Preventive Maintenance
FXLN8362 3-axis $\pm 8/\pm 16$ g Analog Out, low bandwidth	Now	Now	
FXLN8371 3-axis $\pm 2/\pm 8$ g Analog Out, high bandwidth	Now	Now	
FXLN8372 3-axis $\pm 8/\pm 16$ g Analog Out, high bandwidth	Now	Now	
<ul style="list-style-type: none"> • High bandwidth, 2.7 kHz (XY axes), 600 Hz (Z axis), • Low bandwidth, 1.1 kHz (XY axes), 600 Hz (Z axis), • Low power 200 μA in running mode, low voltage • High performance industrial grade • 1.7...3.6 Volt, 3 x 3 x 1mm, 0.65mm pitch 12 pins QFN 			
MMA6900Q 2-axis XY, ± 3.5 g, 11 bits, SPI, AECQ100	Now	Now	Vehicle stability control Electronic parking brake Car alarm Trailer tilt control Absolute tilt measurement Noisy environment
MMA6901Q 2-axis XY, ± 5 g, 11 bits, SPI, AECQ100			
<ul style="list-style-type: none"> • AECQ100 qualified, -40°C;+105°C • Low pass filters for noisy environment • Low TCO over the wide temperature window. • QFN 6x6mm, 16 pins QFN 			



Freescale's Sensor Portfolio

Gyroscopes



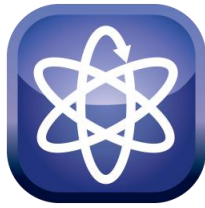

Sensor Type: Gyroscopes

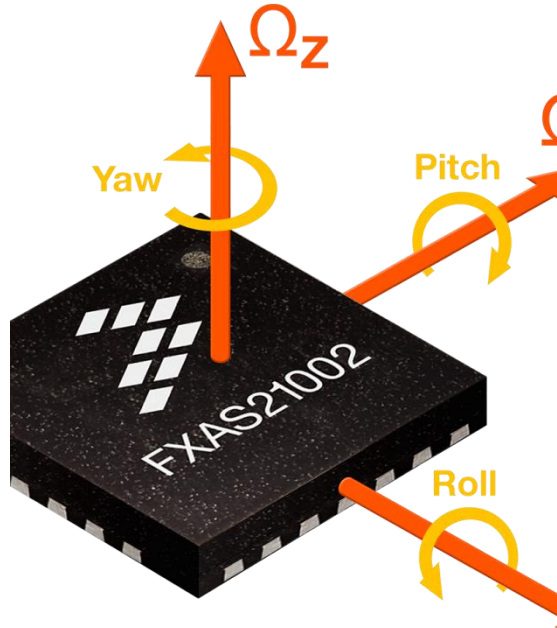

- MEMS gyroscopes reliably sense and measure the angular rate of an object, under complex and severe operating conditions
- They enable both user interface and image stabilization applications
- *When you see an accelerometer, think gyroscope too!*



Gyroscope

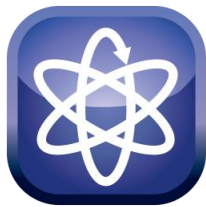

FXAS21002 3-axis Digital Gyroscope

- Full scale range +/-2000°/sec
- Angular speed resolution better than 0.02°/sec
- Best-in-class power performance: **2.7mA (Active), 1.5mA (Ready), 2uA (Standby)**
- Fast Transition from Standby to Active Mode (**50 ms**)
- 1.95 V-3.6 V voltage supply, 4 x 4 x 1 mm QFN
- Complete sensor fusion enablement suite



	Sample	Production	Applications
	Now	Now	Inertial Navigation Gaming Remote Control Smart Phones Stabilization



Gyroscopes

Applications and Use Cases

- **Health and Safety**
 - Activity Monitoring, Elderly monitoring
 - Apps Based On Gesture Recognition
- **Gaming**
 - Excellent high frequency response in the presence of high g forces
 - Next Gen: 9-axis sensor fusion for rotation and precise orientation
- **Digital Cameras**
 - Improved high frequency response to orientation changes for tilt and image stabilization
- **Compass Applications**
 - Improved performance against magnetic disturbance from ferromagnetic materials
- **Internet of Things**
 - Multiple applications for accurate positioning and advanced user interface
 - Improved context awareness and control



Freescale's Sensor Portfolio Magnetometers





Sensor Type: Magnetometers



- Magnetometers: instrument for measuring the magnitude and direction of a magnetic field
- When combined with an accelerometer to compensate the tilt, it is primarily used as an eCompass. It allows map alignment while moving



Magnetometers



	Sample	Production	Applications
<p>MAG3110G 3-axis Digital Magnetometer</p> <p>Capable of measuring geomagnetic fields</p> <ul style="list-style-type: none"> • Wide dynamic range +/- 1000 μT (10 Gauss) • Low power in measurement mode 8.6 μA • ODR output data rate up to 80 Hz • Interrupt pin trigger when new data available • Tilt compensation and Soft/Hard Iron calibration software available • 1.95...3.6 Volt, 2 x 2 x 0.85 mm DFN 	Now	Now	Industrial Compass Current Sensing Presence Detection Car Detect Industrial Safety Magnetic Tamper Sports Watch Diving Watch



6 DOF Accelerometer and Magnetometer: Key Products



	Sample	Production	Applications
<p>FXOS8700CQ COMBO 6-axis Magnetometer and Accelerometer</p> <ul style="list-style-type: none"> Capable of measuring geomagnetic fields with Tilt compensation Wider dynamic range +/- 1200 μT ODR up to 800 Hz by sensors, or 400 Hz in hybrid mode Embedded interrupts and pre-programmed functions Low power 80 μA in Hybrid mode @ 25 Hz 1.95...3.6 Volt, 3 x 3 x 1.2 mm QFN 	Now	Now	<ul style="list-style-type: none"> Industrial Compass Current Sensing Presence Detection Car Detect Industrial Safety Magnetic Tamper Sports Watch Diving Watch



Freescale's Sensor Portfolio

Pressure Sensors



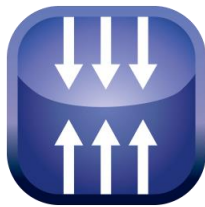

Sensor Type: Pressure Sensors



Devices are composed of single silicon, piezoresistive devices capable of monitoring processes in the industrial, medical, automotive, and avionics industries. Pressure sensors are composed of the following reference designs:

- Differential: difference in pressure between two points is measured as pressure is applied to both sides of the die/sensing element

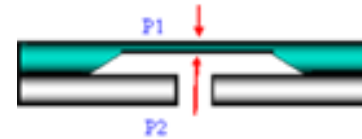

- Gauge: bottom side is exposed to the atmosphere, while pressure is applied to top of die

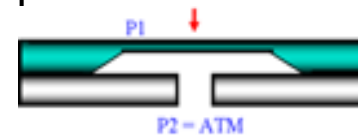

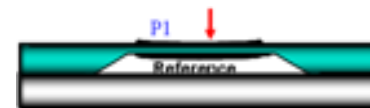

- Absolute: pressure is applied to the top of the die while the bottom of the die is a vacuum-sealed reference

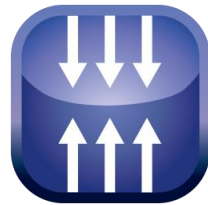

Pressure Sensors: Key Products

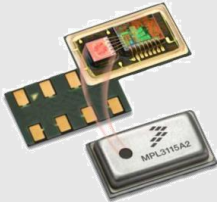

	Sample	Production	Applications
<p>MPL3115A 20...115 kPa Digital Absolute Pressure Sensor</p> <ul style="list-style-type: none"> • Compensated sensor • Direct readings in Pressure, Altitude and Temperature • Typical 25 cm altimeter resolution • Embedded software providing real data • Embedded interrupts and pre-programmed functions • 3 x 5 x 1 mm LGA package 	Now	Now	Altimeter Sport Watch Medical Monitoring Breath Analyzer Air Conditioning
<p>Medical Pressure Sensors</p> <ul style="list-style-type: none"> • MPXM2051xx, Blood Pressure Monitoring, 0 – 50 kPa, gauge • MPX2010xx, MPX7002xx, MPX5004xx, Respirator Machine, low pressure range family (+/-2kPa, 4kPa, 6kPa, 10kPa) • MPX5010xx, MPXM2010xx, Medical bed, Air mattress • MPX5004xx, MPXV7002xx, Sleep Aepnea 	Now	Now	Medical Blood Pressure Monitoring Respirator Machine Medical Bed Sleep Aepnea
<p>FXTH87XXT1 Tire pressure monitoring Sensor</p> <ul style="list-style-type: none"> • Absolute pressure sensor (100 to 1500kPa) • Temperature sensor • Dual axis accelerometer • Battery voltage monitoring • S08 8 bit MCU with 16kB flash, 512B RAM • TPMS firmware library • 315/434MHz RF transmitter, ASK/FSK capable • 125kHz LF communication interface • QFN 7x7x2.2 mm package 	Now	Now	Automotive Passenger car Light Truck Trucks Motorcycle Industrial vehicles Aftermarket





Pressure Sensor Portfolio

A – Absolute
D – Differential
G – Gauge
V – Vacuum

MPX10/12/53 **D G**
10...53 kPa
SOP, Unibody

Uncompensated

High sensitivity analog output
Need external circuit for compensation and amplification

MPX2 Series **A D G V**
10...300 kPa
ChipPak, Unibody

Temperature Compensated

Integrated temperature compensation
Need external circuit for amplification

MPX7 Series **D G**
 $\pm 2... \pm 25$ kPa
SOP

Integrated Pressure Sensor

Integrated signal conditioning for temperature compensation, linearization and amplification

MPX4 Series **A D G**
6...250 kPa
SOP, SSOP, Unibody

MPX5 Series **A D G V**
4...1'000 kPa
SOP, SSOP, Unibody

MPX6 Series **A**
100...400 kPa
SOP, SSOP

MPL3115 (Digital I²C) **A**
115 kPa Smart Baro/Pressure
3 x 5 mm LGA

Integrated Digital Pressure Sensor

I²C Digital Interface with digitized output in Pascals or meters.

Package Examples

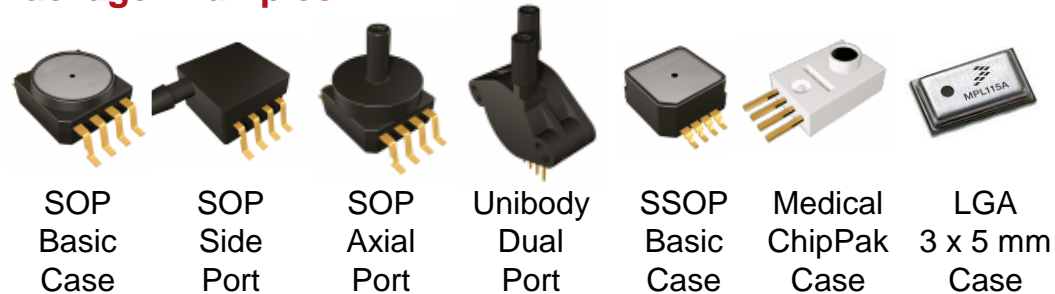

Freescalé's Sensor Portfolio Platforms





Motion Sensing Platforms: Key Products

			Sample	Production	Applications
MMA955xL	32-Bit 16K Flash CPU and 3-axis Accelerometer		Now	Now	Tilt Measurement
FXLC95000CL	32-Bit 128K Flash CPU and 3-axis Accelerometer		Now	Now	Vibration Monitor
	<ul style="list-style-type: none"> Embedded ± 2, ± 4, ± 8 g 3-axis 16-Bit accelerometer module 32-Bit CF V1 CPU with MAC multiply and accumulate block 16K or 128K on-chip Flash, 2K or 16K on-chip SRAM SPI, I²C (master and slave), GPIO, ADC, PWM 1.8V, 3 x 3 x 1 mm QFN, or 3 x 5 x 1 mm QFN Pre-flashed Freescale firmware (3 Versions) or MQX CodeWarrior CW10.x supported 				Pedometer
					Home Health
					Power Management
					eCompass
					Asset Tracking
					Collision Recorder
Part Number	Firmware	User Memory Size			
MMA9559L	Basic	14K Flash 1.5K SRAM	Now	Now	
MMA9550L	Infrastructure	6.5K Flash 0.5K SRAM	Now	Now	
MMA9551L	Infrastructure and Gesture	4.5K Flash 0.5K SRAM	Now	Now	
MMA9553L	High end pedometer	1.5K Flash 0.2K SRAM	Now	Now	
FXLC95000	MQX enabled	128K Flash 16K SRAM	Now	Now	

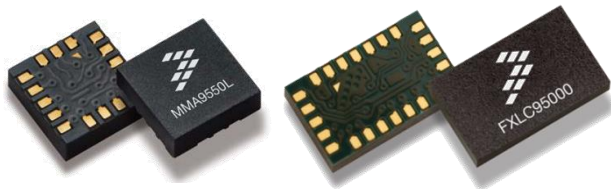

3-Axis MEMS Accelerometer	
ROM	ColdFire
Flash	32-Bit
RAM	V1 Core
ADC	SPI
GPIO	I2C



Development Tools



Sensor Fusion Development Kit

- Enables quick development and prototype of sensor fusion applications
- Includes
 - Kinetis Freedom Development board
 - Freescale Multi sensor platform
 - Link for SW download page for library
- Optional commercial support
- Part numbers
 - FRDM-SFUSION with community support (<\$200)
 - FRDM-SFUSION-S with 50 hours commercial support (\$10K)



Key Development Tools

Part Number	Freescal Devices	Online Availability	Price	Comments
BRKT-STBC-AGM01	FXAS21002, FXOS8700	NOW	\$11.95	Breakout board with access to all I/O
FRDM-STBC-AGM01	FXAS21002, FXOS8700	NOW	\$15.95	Sensor Shield Board. Pairs with a variety of Kinetis MCU boards including KL25Z, KL26Z, K22F, K64F
FRDM-K64F-AGM01	FXAS21002, FXOS8700, FRDM-K64F	NOW	\$52.95	Sensor Shield + MCU sold as a single kit
FRDM-FXS-MULTI-B FRDM-FXS-MULT2-B	FXAS2100x, FXOS8700, MPL3115, MAG3110, MMA955x, MMA8652, FXLS8471	Now	\$99.00	Sensor shield board with Bluetooth. MULT2-B updates gyro from pre-production version (FXAS21000) to released version (FXAS21002)



BRKT-STBC-AGM01



FRDM-STBC-AGM01

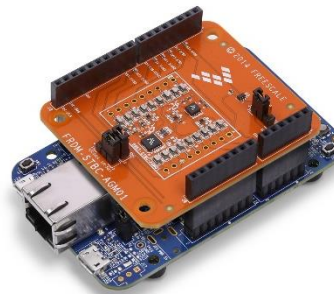

FRDM-K64F-AGM01



FRDM-FXS-MULT2-B



Freescal Sensor Fusion Library



Full featured sensor fusion library, including the award winning e-compass software



Fully open source, eliminating proprietary constraints, increasing flexibility, and decreasing time-to-market

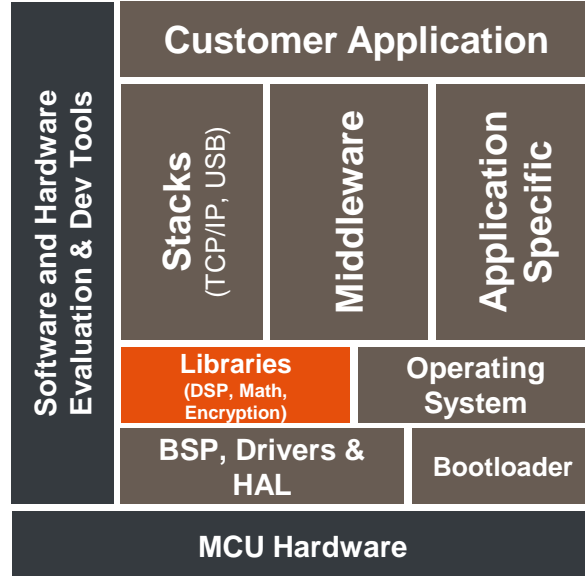

Product Features

- Functionality
 - 3-axis, 2-axis heading, 6-axis eCompass, 6-axis indirect Kalman filter, 3-axis relative rotation, and 9-axis indirect Kalman filter
 - Programmable sampling, fusion rates, and frame of reference,
- Included projects
 - Kinetis K20, KL25Z, KL26Z, KL46Z, and K64F Freedom boards
 - Use of Freescale Multi sensor boards
 - CodeWarrior and Kinetis Design Studio
- Additional commercial support and services available



Intelligent Sensor Framework 2.1 for Kinetis MCUs

ISF 2.1 for Kinetis MCUs allows you to write an embedded sensor application in less than 30 minutes without writing a single line of code using Processor Expert technology



• Differentiating Points

- Sensor application code auto-generation using Processor Expert technology
- Deployable across entire line of Freedom development platforms
- Sensor Fusion library has been integrated as an “Orientation” sensor
- Register Level Interface allows low-level access to sensor registers



• Product Features

- Projects available for FRDM-KL25Z, FRDM-K22F and FRDM-K64F
- Supports a broad set of Freescale sensors including MMA8652/8653, MAG3110, FXOS8700, FXAS21002, FXLS8471, MPL3115 and others
- Example projects available for both CodeWarrior 10.6 and Kinetis Design Studio 2.0 Integrated Development Environments



Applications

- Sensor Data Analytics
- Internet of Things
- Consumer Electronics
- Wearable Electronics
- Medical Devices





Session Review and Wrap-up



Freescale Product Programs

SafeAssure Functional Safety Program

Functional Safety Simplified

The Freescale SafeAssure functional safety program is designed to help simplify the process of achieving system compliance with functional safety standards in the automotive and industrial markets



Energy-Efficient Solutions Program

Energy Efficient by Design

The Energy-Efficient Solutions mark highlights selected products that excel in effective implementation of energy-efficient technologies



Product Longevity Program

Supply Assurance

For the automotive and medical segments, a broad range of products are made available for a minimum period of 15 years and 10 years for other market segments



Summary

- Freescale offers a strong portfolio of diverse sensor types
- Intelligent integration with the right combination of sensor types become human machine interfaces (HMI)
- Hopefully with this knowledge, ingenuity has been seeded in a quest to find novel solutions
- Multiple sensor inputs leveraged to perform multiple application functions can solve design challenges
- Awareness of customizable software can extend sensor use cases
- Consciousness of common software platforms and common tools will shorten design time





www.Freescale.com