



It's Not a Tradeoff. It's Trading Up.

# Low Power. High Performance.

### Freescale: Committed to Your Future

The HCS08 Family extends Freescale's\* tradition of industry-leading 8-bit microcontrollers that began with the HC05 Family and continued with the HC08 Family.

As the world's No. 1 producer of embedded processors, Freescale delivers a comprehensive range of 8-, 16- and 32-bit MCUs with industry-leading design support. We plan to grow the most advanced technology portfolio along with the services that speed your time-to-market. We're here today—and we're here to stay—for the design engineer that demands more than just a component from a catalog.

To learn more about Freescale's microcontrollers or to order a development kit, please visit [www.freescale.com/mcu](http://www.freescale.com/mcu).

Pin-Compatible Scalable Memory Solutions

	QFP64	LQFP44	SDIP42	LQFP32	SOIC28
64K	GB60	GT60 RC60 RD60 RE60	GT60	RC60 RD60 RE60	RC60 RD60 RE60
32K	GB32	GT32 RC32	GT32	RC32 RD32 RE32	RC32 RD32 RE32
16K		GT16 RC16 RD16 RE16	GT16	RC16 RD16 RE16	RC16 RD16 RE16
8K				RE8	RE8

#### Safe Harbor Statement

Except for historical information, all of the expectations and assumptions contained in this document are forward-looking statements involving risk and uncertainties. Important factors that could cause actual results to differ materially from such forward-looking statements, include, but are not limited to, the competitive environment for our products, changes of rates of all related services, and legislation that may affect the industry. For additional information regarding these and other risks associated with Company's business refer to the Company's reports with the SEC.

\*The Semiconductor Products Sector of Motorola, Inc. became Freescale Semiconductor, Inc. in 2004.

#### Learn More:

For more information about Freescale products, please visit [www.freescale.com](http://www.freescale.com).

### HCS08 Family of 8-bit Microcontrollers

Freescale takes the next step forward on the controller continuum with the HCS08 Family of 8-bit microcontrollers. An extension of the HC08 Family, the HCS08 Family offers extended battery life with maximum performance down to 1.8V, industry-leading Flash technology and innovative on-chip development support. It's ideal for high-volume battery-operated devices such as

- > Handheld instruments
- > Utility meters
- > Electronic keys and locks
- > Electronic toys
- > Thermostats
- > Universal remote controls
- > Portable audio devices
- > Digital cameras/camcorders



Freescale™ and the Freescale logo are trademarks of Freescale Semiconductor, Inc. All other product or service names are the property of their respective owners. This product incorporates SuperFlash™ technology licensed from SST.

© Freescale Semiconductor, Inc. 2004

BRHCS08  
REV 3







### freescal<sup>e</sup>s Extended Battery Life Technology

Extract the most from any battery with multiple power management modes, fast startup and flexible multifrequency clock sources including a programmable, componentless, internal clock generator.

- > Multiple power management modes
  - Ultra-low power-down Stop 1 mode (typically 20 nA at 2V)
  - Partial power-down Stop 2 mode (typically 400 nA at 2V)
  - HC08s' normal Stop 3 mode (typically 500 nA at 2V)
  - Optional auto-wake up timer with internal 2 KHz oscillator can run while in Stop 2 or Stop 3 modes to periodically wake up the CPU (typically 300 nA adder)
- > On-chip programmable clock generator with frequencies from 4 MHz to 20 MHz bus rates
  - Use the programmable internal oscillator for fast startup and brief periods where high performance is required
  - Very stable over time and temperature (+/-2%)
  - No external components needed, thus leading to low overall system costs.
- > External 32 KHz or higher clock sources can be switched from internal oscillator anytime
- > Software selectable divide down bits
- > Precision 10-bit A/D specified to operate reliably and accurately down to 1.8V (total error nominally 1.1 LSB)



### Exceptional On-Chip Debug and Emulation Capability

An on-chip background debug module with on-chip trigger and trace capability is designed to allow expensive emulators to be replaced by cost-effective serial real-time emulation and debug cable.

- > Real-time emulation of MCU functions at HCS08's full operating voltage and frequency range with no limitations like traditional emulators
- > Non-intrusive debugging through a single, dedicated pin eliminates the need and cost of cumbersome emulator cables
- > On-chip hardware for multiple breakpoints
- > Nine flexible triggers and buffer hardware replaces an emulator's expensive bus analyzer
- > View and change internal registers and memory while running application
- > Single step, run, or trace application code on the target processor

### All the Power of Freescale's Advanced Third-Generation 0.25 micron Flash Technology—Today!

In 1994, Motorola (now Freescale Semiconductor, Inc.) was among the first to ship embedded Flash in volume quantities. Today, our third-generation, in-application reprogrammable Flash makes the benefits of Flash even more affordable. Additional features include

- > Up to 100,000 write/erase cycles
- > Very robust with 15-year minimum data retention specification, 100 years typical
- > Command programming interface designed to eliminate complex programming algorithms
- > Flash easily used for data EEPROM storage at no additional cost
- > Read down to 1.8V, write down to 2.1V
- > Programs 8 bits as fast as 20 µsec for reduced programming cost

### Development Tools and Support

Freescale's comprehensive portfolio of services and tools help make it simple to incorporate HCS08 microcontrollers into your design and to reduce time to market. Chose from on-line training, large application note library, reference designs, technical FAQs, and high quality, cost-effective hardware and software tools.

- > Metrowerks CodeWarrior™ Development Studio for HCS08, Special Edition
  - Industry-leading Integrated Development Environment (IDE) that is common across Freescale architectures for easy migration
  - Dramatically reduce development time and improve code quality with Processor Expert™ auto-code generator for on-chip peripherals
  - Develop and debug software without waiting for target hardware or requiring an evaluation board using full-chip simulation
  - Package includes assembler, linker, debugger, 4 KB limited C compiler and Flash programming software
  - Order free CD as CDCWSEHC08 or download from Web
- > Additional CodeWarrior developer tool upgrades are available to speed development
  - Compiler upgrade to 32 KB or 64 KB memories
- > Standard Edition includes advanced data visualization software designed to allow developers to see real-time feedback of simulation utilizing graphic representation such as displays and gauges while stimulating I/O with graphic representations such as a potentiometer
- > Professional Edition includes additional advanced tools such as code coverage, performance analysis and the Processor Expert custom bean-generating Wizard
- > MC9S08GB60 Demonstration Board (M68DEMO908GB60)
  - Features a battery-powered 64-pin GB60 device, LEDs, push buttons, a prototyping area, access to I/O for user-provided prototyping, and a software demo with application code utilizing the A/D, timers and I/O
- > MC9S08GB60 Evaluation Board (M68EVB908GB60)
  - Features the 64-pin GB60 device, large LCD display, potentiometer, push buttons, a large prototyping area, access to I/O for user-provided prototyping, and a universal power supply
  - Develop, program and debug code using the included CodeWarrior Development

MC9S08GB60 Demonstration Board (M68DEMO908GB60)

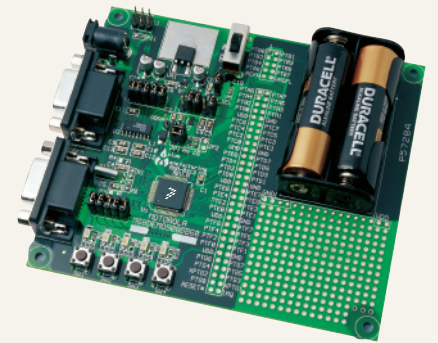

Studio for HCS08, Special Edition and pre-programmed Flash monitor—no additional hardware required

- > M68MULTILINKS08 is a universal in-circuit programmer/debugger for HCS08s with on-chip BDM
- > M68CYCLONEPRO is a universal stand-alone programmer with the capabilities of the M68MULTILINKS08 plus the ability to function as a standalone programmer with pushbuttons and LEDs to control operation. It supports HCS08s and HCS12s and includes serial, Ethernet and USB interfaces

### Features and Benefits

MC9S08GB60, MC9S08GB32, MC9S08GT60 and MC9S08GT32 Devices

The first four members of the HCS08 Family are available now. A rich variety of integrated peripherals make the devices versatile enough to work with a wide range of systems.

### High-Performance 8-bit HCS08 CPU

- > Object-code compatible with Freescale's 68HC05 and 68HC08 architecture for easy migration
- > Provides the higher performance required of many 8-bit applications as fast as 50 nsec minimum instruction cycle time at 20 MHz bus
- > Allows efficient, compact modular coding in assembly or C with full 16-bit stackpointer and stack-relative addressing
- > Efficient instruction set with multiply and divide that is easy to learn and use

Since the announcement of these devices we have added a total of 15 new high-performance HCS08 products to the family. Contact your local distributor or visit our Web site for more details.

### BLOCK DIAGRAM

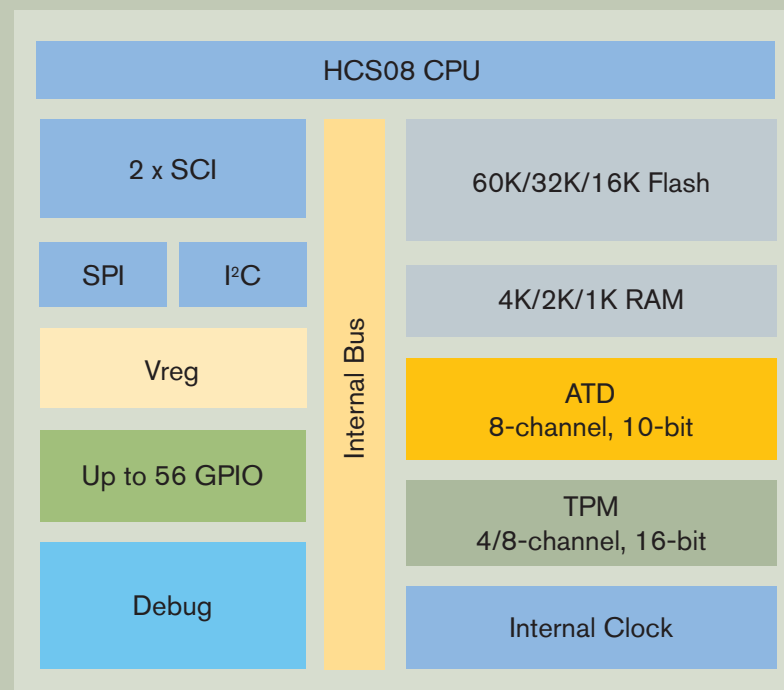

### Memory

- > In-application, reprogrammable Flash memory (up to 60 KB)
- > Large up to 4 KB on-chip random access memory (RAM)

### Peripherals

- > Up to eight programmable, 16-bit, timer channels with selectable input capture, output compare or pulse width modulation (PWM)
  - Each channel can be edge- or center-aligned, full-buffered PWM
- > Internal clock generator—to help reduce board space and system costs by eliminating external components
- > 8-channel, 10-bit analog-to-digital converter (A/D) provides an easy interface to analog inputs such as sensors
  - Reliable, accurate, specified operation down to 1.8V

- > Extensive serial communication capabilities
  - Two asynchronous serial communications modules (SCIs)
  - One synchronous serial communications module (SPI)
  - One I<sup>2</sup>C communications module
- > Flexible I/O—designed to allow direct drive of LED and other circuits to help eliminate external drivers and to help reduce overall system costs
- > Integrated system protection features to help reduce cost and to help increase reliability—including watchdog timer, on-chip low-voltage detect/reset at nominal 1.8V, and low-battery detect at nominal 2.1V at 2.4V
- > 64 QFP, 44 QFP and 42 SDIP packages—with more to come as family develops

