



Freescale Semiconductor, Inc.

56800 Hybrid Controller

*3-Phase SR Motor
Control with
Hall Sensors
Reference Design*

*Designer Reference
Manual*

*DRM032/D
Rev. 0, 03/2003*

MOTOROLA.COM/SEMICONDUCTORS



Freescale Semiconductor, Inc.

Freescale Semiconductor, Inc.

**For More Information On This Product,
Go to: www.freescale.com**

Designer Reference Manual

Designer Reference Manual — Rev 0

by: Radim Visinka, Jaroslav Musil
Motorola Czech Systems Laboratories
Roznov pod Radhostem, Czech Republic

Revision history

To provide the most up-to-date information, the revision of our documents on the World Wide Web will be the most current. Your printed copy may be an earlier revision. To verify you have the latest information available, refer to:

<http://www.motorola.com/semiconductors>

The following revision history table summarizes changes contained in this document. For your convenience, the page number designators have been linked to the appropriate location.

Revision history

Date	Revision Level	Description	Page Number(s)
February 2003	1	Initial release	N/A

List of Sections

Section 1. Introduction	13
Section 2. Control Theory	17
Section 3. System Concept	35
Section 4. Hardware	41
Section 5. Software Design	57
Section 6. Application Setup	75
Appendix A. References	89
Appendix B. Glossary	91



Table of Contents

Section 1. Introduction

1.1	Contents	13
1.2	Introduction	13
1.3	Motorola DSP Advantages and Features	13

Section 2. Control Theory

2.1	Contents	17
2.2	Target Motor Theory	17
2.3	Control Techniques for Switched Reluctance Motors	24

Section 3. System Concept

3.1	Contents	35
3.2	System Outline	35
3.3	Application Description	37

Section 4. Hardware

4.1	Contents	41
4.2	Hardware Implementation	41
4.3	DSP56F805EVM Control Board	45
4.4	3-Phase Switched Reluctance High-Voltage Power Stage	49
4.5	3-Phase Switched Reluctance Low-Voltage Power Stage	51
4.6	Optoisolation Board	53
4.7	Motor-Brake Specifications	55

Section 5. Software Design

5.1 Contents57

5.2 Introduction57

5.3 Data Flow58

5.4 Software Implementation62

5.5 Implementation Notes69

Section 6. Application Setup

6.1 Contents75

6.2 Application Description75

6.3 Application Set-Up79

6.4 Projects Files84

6.5 Application Build & Execute85

Appendix A. References

Appendix B. Glossary

Designer Reference Manual — 3-Phase SRM Control with Hall Sensors

List of Figures

Figure	Title	Page
2-1	3-Phase 6/4 SR Motor	18
2-2	Phase Energizing	20
2-3	Magnetization Characteristics of the SR Motor	21
2-4	3-Phase SR Power Stage.	23
2-5	Soft Switching and Hard Switching.	24
2-6	Voltage Control Technique	25
2-7	Voltage Control Technique - Voltage and Current Profiles.	26
2-8	Control Technique	28
2-9	Flow Chart - Start-Up Process	30
2-10	Flow Chart - Commutation Phase.	33
3-1	System Concept	38
4-1	3-Phase SR Low-Voltage Platform Configuration.	43
4-2	3-Phase SR High-Voltage Platform Configuration	44
4-3	Block Diagram of the DSP56F805EVM	46
4-4	DSP56F805EVM Jumper Reference	47
4-5	Connecting the DSP56F805EVM Cables.	48
4-6	Block Diagram	50
4-7	Block Diagram	52
4-8	Inductance Characteristic.	56
5-1	Data Flow	59
5-2	State Diagram - General Overview.	64
6-1	RUN/STOP Switch and UP/DOWN Buttons.	76
6-2	USER and PWM LEDs at DSP56F805EVM.	77
6-3	PC Master Software Control Window	79
6-4	Setup of the 3-phase HV SR Motor Control Application	80
6-5	Set-up of the 3-phase LV SR Motor Control Application	81
6-6	DSP56F805EVM Jumper Reference	83
6-7	Target Build Selection.	86
6-8	Execute Make Command	86



List of Figures

Freescale Semiconductor, Inc.

Designer Reference Manual — 3-Phase SRM Control with Hall Sensors

List of Tables

Table	Title	Page
1-1	Memory Configuration	14
3-1	Specifications of the Motor and Hall Sensors	36
4-1	DSP56F805EVM Default Jumper Options	47
4-2	Electrical Characteristics	51
4-3	Electrical Characteristics	53
4-4	Electrical Characteristics	54
4-5	Motor - Brake Specifications	55
6-1	Motor Application States	77
6-2	DSP56F805EVM Jumper Settings	83



Section 1. Introduction

1.1 Contents

1.2	Introduction	13
1.3	Motorola DSP Advantages and Features	13

1.2 Introduction

This paper describes the design example of a 3-phase SR (Switched Reluctance) motor drive. It is based on Motorola’s DSP56F805 dedicated motor control device. The software design takes advantage of Quick_Start developed by Motorola.

SR motors are gaining wider popularity for variable speed drives. This is due to their simple low-cost construction characterized by an absence of magnets and rotor winding, high performance over wide speed range, and fault tolerant design of the power stage. Availability and cost of the necessary electronic control make the SR drive a viable alternative to other commonly used motors like AC, BLDC, PM Synchronous or universal motors for a number of applications.

The concept of the presented application is that of a speed closed loop SR drive using a Hall position sensor. The application serves as an example of an SR motor control system design using a Motorola DSP.

1.3 Motorola DSP Advantages and Features

The Motorola DSP56F805 is very suited for digital motor controls, combining the DSP’s calculation capability with MCU’s controller features on a single chip. These DSP’s offer many dedicated peripherals like a Pulse Width Modulation (PWM) unit, an Analog-to-Digital

Converter (ADC), timers, communication peripherals (SCI, SPI, CAN), on-board Flash and RAM.

The DSP56F805 provides the following peripheral blocks:

- Two Pulse Width Modulator modules (PWMA & PWMB), each with six PWM outputs, three Current Sense inputs, and four Fault inputs, fault tolerant design with deadtime insertion, supports both Center- and Edge-aligned modes
- Twelve bit, Analog to Digital Convertors (ADCs), supporting two simultaneous conversions with dual 4-pin multiplexed inputs, ADC can be synchronized by PWM
- Two Quadrature Decoders (Quad Dec0 & Quad Dec1), both with four inputs, or two additional Quad Timers A & B
- Two dedicated General Purpose Quad Timers totalling 6 pins: Timer C with 2 pins and Timer D with 4 pins
- CAN 2.0 A/B Module with 2-pin ports used to transmit and receive
- Two Serial Communication Interfaces (SCI0 & SCI1), both with two pins, or four additional GPIO lines
- Serial Peripheral Interface (SPI), with configurable 4-pin port, or four additional GPIO lines
- Computer Operating Properly (COP) Watchdog timer
- Two dedicated external interrupt pins
- Fourteen dedicated General Purpose I/O (GPIO) pins, 18 multiplexed GPIO pins
- External reset pin for hardware reset
- JTAG/On-Chip Emulation (OnCE)
- Software-programmable, Phase Lock Loop-based frequency synthesizer for the DSP core clock

Table 1-1. Memory Configuration

	DSP56F801	DSP56F803	DSP56F805	DSP56F807
Program Flash	8188 x 16-bit	32252 x 16-bit	32252 x 16-bit	61436 x 16-bit

Table 1-1. Memory Configuration

	DSP56F801	DSP56F803	DSP56F805	DSP56F807
Data Flash	2K x 16-bit	4K x 16-bit	4K x 16-bit	8K x 16-bit
Program RAM	1K x 16-bit	512 x 16-bit	512 x 16-bit	2K x 16-bit
Data RAM	1K x 16-bit	2K x 16-bit	2K x 16-bit	4K x 16-bit
Boot Flash	2K x 16-bit	2K x 16-bit	2K x 16-bit	2K x 16-bit

In addition to the fast Analog-to-Digital converter, the most interesting peripherals, from the SRM application point of view, are the Pulse-Width-Modulation (PWM) module and the 16-bit Quadrature Timer.

The PWM module offers a lot of freedom in its configuration enabling the efficient control of the SR motor. It has the following features:

- Three complementary PWM signal pairs, or six independent PWM signals
- Features of complementary channel operation
- Deadtime insertion
- Separate top and bottom pulse width correction via current status inputs or software
- Separate top and bottom polarity control
- Edge-aligned or center-aligned PWM signals
- 15 bits of resolution
- Integral reload rates from one to 16, half-cycle reload capability
- Individual software-controlled PWM output
- Programmable fault protection
- Polarity control
- 20-mA current sink capability on PWM pins
- Write-protectable registers

The SR Motor control application utilizes the PWM module set in the independent PWM mode, permitting generation of control signals for all

switches of the power stage fully independently. In addition to the PWM generators, the PWM outputs can be controlled separately by software, allowing the setting of the control signal to logical 0 or 1. Thus, the state of the control signals can be changed immediately at a given rotor position (phase commutation) without changing the content of the PWM value registers.

The Quadrature Timer is an extremely flexible module, providing all required services related to time events. It has the following features:

- Each timer module consists of four 16-bit counters/timers
- Count up/down
- Counters are cascadable
- Programmable count modulo
- Max count rate equals peripheral clock/2 when counting external events
- Max count rate equals peripheral clock when using internal clocks
- Count once or repeatedly
- Counters are preloadable
- Counters can share available input pins
- Each counter has a separate prescaler
- Each counter has capture and compare capability

The SR motor application utilizes three channels of the Quadrature Timer module in Input Capture mode. It enables sensing of the rotor position using position Hall sensors.

Section 2. Control Theory

2.1 Contents

2.2	Target Motor Theory	17
2.2.1	Switched Reluctance Motors	17
2.2.2	Magnetization Characteristics of an SR Motor	20
2.2.3	Digital Control of an SR Motor	21
2.3	Control Techniques for Switched Reluctance Motors	24
2.3.1	Voltage Control of an SR Motor	25
2.3.2	Position Sensing Using Hall Sensors	26
2.3.3	Control Technique of SR Motors Using Hall Sensors	27

2.2 Target Motor Theory

2.2.1 Switched Reluctance Motors

A Switched Reluctance (SR) Motor is a rotating electric machine where both stator and rotor have salient poles. The stator winding comprises a set of coils, each of which is wound on one pole. The rotor is created from the lamination in order to minimize the eddy-current losses.

The SR motors differ in number of phases wound on the stator. Each of them has a certain number of suitable combinations of stator and rotor poles. **Figure 2-1** illustrates a typical 3-phase SR motor with 6/4 (stator/rotor poles) configuration.

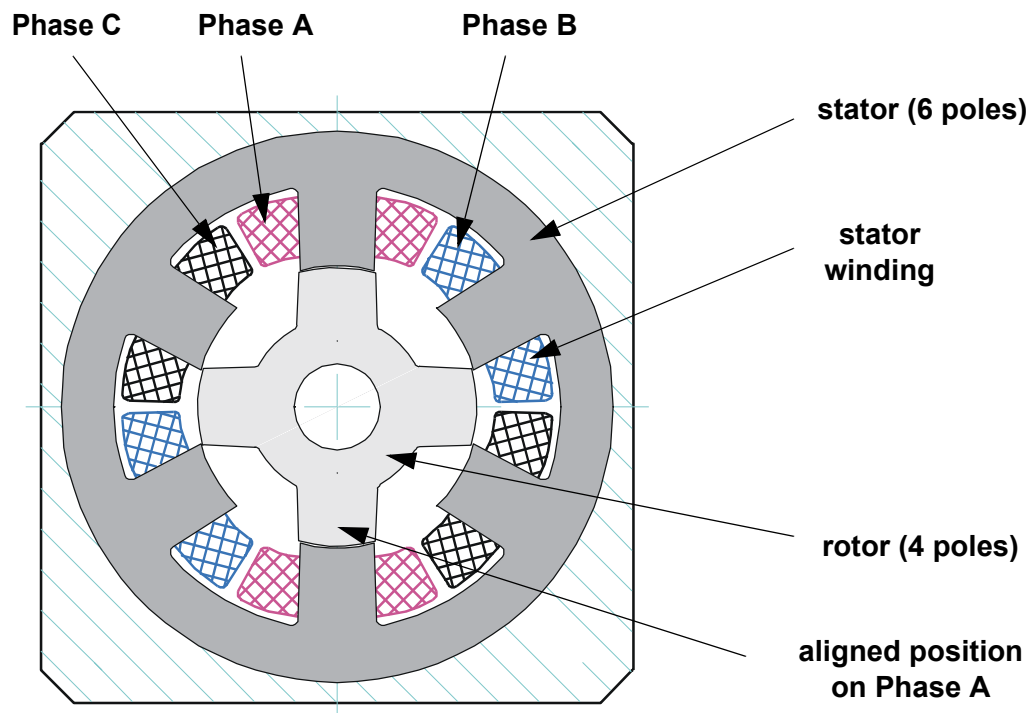

Figure 2-1. 3-Phase 6/4 SR Motor

The motor is driven by a sequence of current pulses applied in each phase. The individual phases are consequently energized, forcing the motor to rotate. The current pulses need to be applied to the respective phase in an exact rotor position to the energized phase. When any pair of rotor poles is exactly in line with the stator poles of the selected phase, the phase is said to be in an aligned position - the rotor is in the position of maximal stator inductance (see [Figure 2-1](#)). If the interpolar axis of the rotor is in-line with the stator poles of the selected phase, the phase is said to be in an unaligned position - the rotor is in a position of minimal stator inductance. The inductance profile of SR motors is a triangular profile with its maximum in the aligned position and its minimum in the unaligned position. [Figure 2-2](#) illustrates the idealized triangular inductance profile of all three phases of an SR motor with highlighted phase A. The individual phases A, B, and C are shifted by electrical 120° relative to each other. The interval, when the respective phase is powered, is called the dwell angle - θ_{dwell} . It is defined by the turn-on θ_{on} and the turn-off θ_{off} angle.

When the voltage is applied to the stator phase, the motor creates torque in the direction of increasing inductance. When the phase is energized in its minimum inductance position, the rotor moves to the forthcoming position of maximal inductance. The movement is defined by the magnetization characteristics of the motor. The typical current profile for the constant phase voltage is shown in **Figure 2-2**. For a constant phase voltage the phase current has its maximum in the position when the inductance starts to increase. This corresponds to the position when the rotor and the stator poles start to overlap. After the phase is turned off, the phase current falls to zero. The phase current, present at the region of decreasing inductance, generates negative torque. The torque, generated by the motor, is controlled by the applied phase voltage and by the appropriate definition of switching turn-on and turn-off angles. For more details, see book by T.J.E. Miller “Switched Reluctance Motors and Their Control”.

The position of the rotor must be measured during the motor operation, since the phases need to be energized properly. This can be achieved by the position sensor, or using some sensorless techniques, evaluating the motor current and voltage.

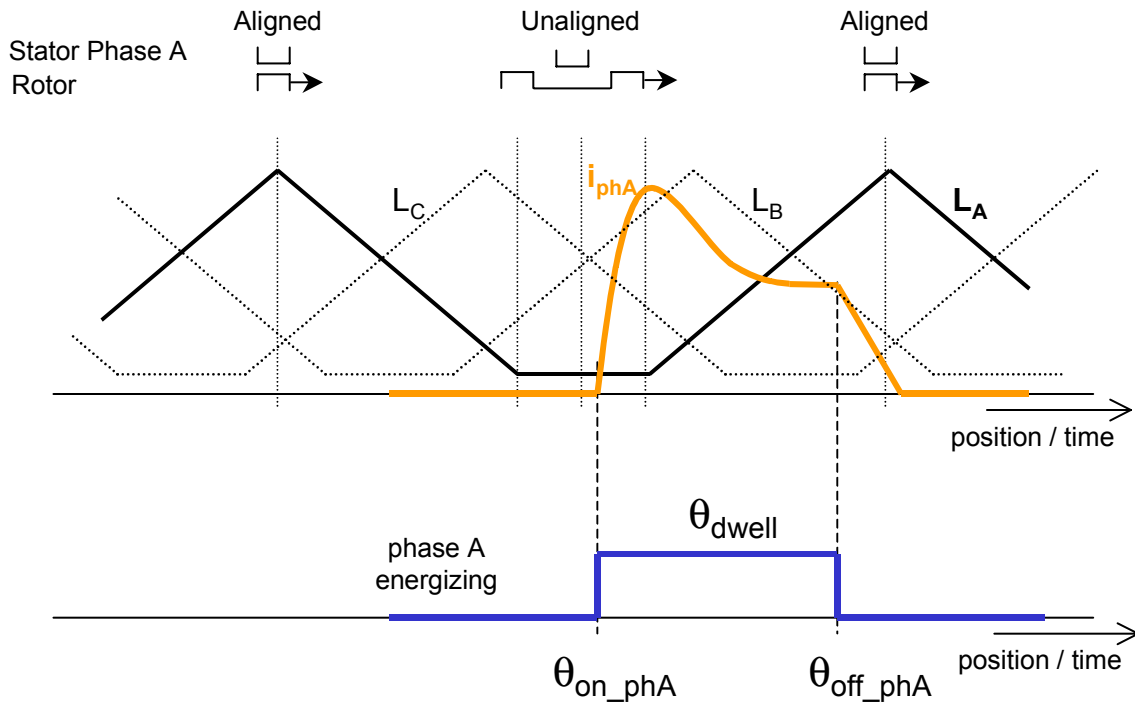

Figure 2-2. Phase Energizing

The motor itself is a low cost machine of simple construction. High speed operation is possible, making the motor suitable for high speed applications, like vacuum cleaners, fans, white goods, etc. The disadvantage of the SR motor is the need of shaft position information for proper switching of individual phases. Also, the motor structure causes noise and torque ripple. The higher the number of poles, the smoother the torque ripple, but motor construction and control electronics become more expensive. Torque ripple can also be reduced by advanced control techniques, such as phase current profiling.

2.2.2 Magnetization Characteristics of an SR Motor

The SR motor is a highly non-linear system. The non-linear theory describing the behavior of the motor has been developed. Based on the theory, a mathematical model can be created. On one hand it enables simulation of the SR motor system and, on the other hand, development

and implementation of sophisticated algorithms for controlling the SR motor is feasible.

The electromagnetic circuit of the SR motor is characterized by a non-linear magnetization. **Figure 2-3** illustrates a magnetization characteristic for a specific SR motor. It is a function between the magnetic flux ψ , the phase current i and the motor position θ . The influence of the phase current is most apparent in the aligned position, where saturation effects can be observed.

The magnetization characteristic curve defines the nonlinearity of the motor. The torque generated by the motor phase is a function of the magnetic flux, therefore the phase torque is not constant for constant phase current for different motor positions. This causes the SR motor torque ripple and noise.

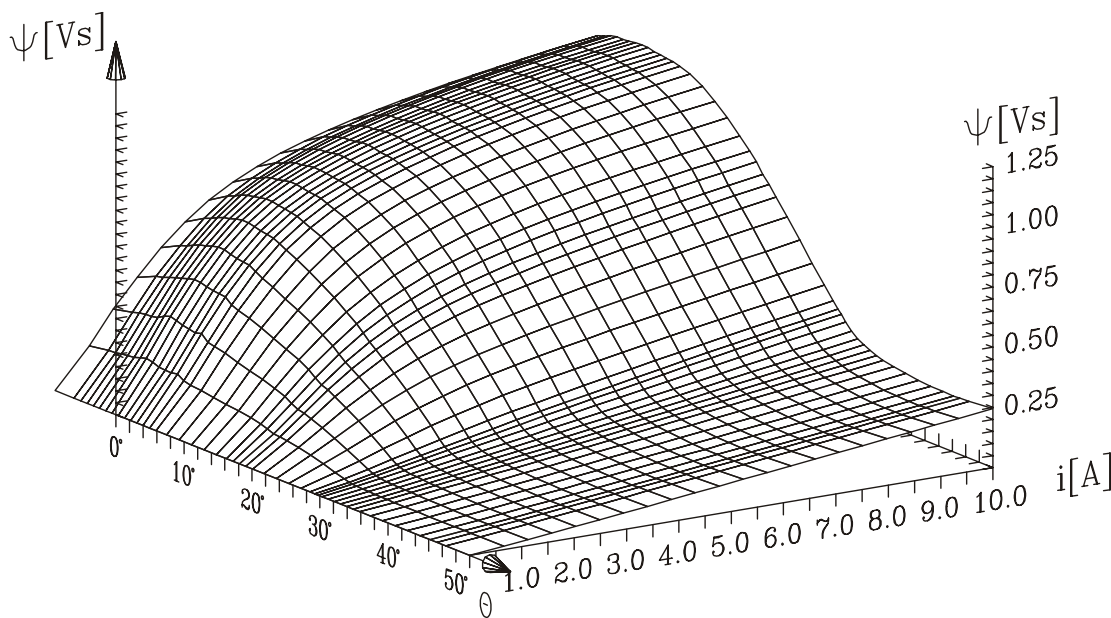

Figure 2-3. Magnetization Characteristics of the SR Motor

2.2.3 Digital Control of an SR Motor

The SR motor is driven by voltage strokes coupled with the given rotor position. The profile of the phase current together with the magnetization

characteristic define the generated torque and thus the speed of the motor. Due to this fact the motor requires an electronic control for the operation. Several power stage topologies are being implemented, according to the number of motor phases and the desired control algorithm. The particular structure of the SR power stage structure defines the freedom of control for an individual phase.

The power stage with two independent power switches per motor phase is the most used topology. Such a power stage for 3-phase SR motors is illustrated in [Figure 2-4](#). It enables a control of the individual phases fully independent on each other and thus permits the widest freedom of control. Other power stage topologies share some of the power devices for several phases, thus saving on power stage cost, but the phases cannot be controlled fully independently. Note that the particular topology of the SR power stage is fault tolerant - in contrast to AC power stages - because it eliminates the possibility of the short circuit.

During a normal operation, the electromagnetic flux in an SR motor is not constant and must be built for every stroke. In the motoring period these strokes correspond to the rotor position when the rotor poles are approaching the corresponding stator pole of the excited phase. In the case of phase A, shown in [Figure 2-4](#), the stroke can be established by switching the switches Q1 and Q2. At low speed operation the Pulse Width Modulation (PWM), applied on the corresponding switches, modulate the voltage level.

Two basic switching techniques can be applied.

- Soft Switching - where one transistor is left turned on during the whole commutation period and PWM is applied to the other one.
- Hard Switching - where PWM is applied to both transistors simultaneously

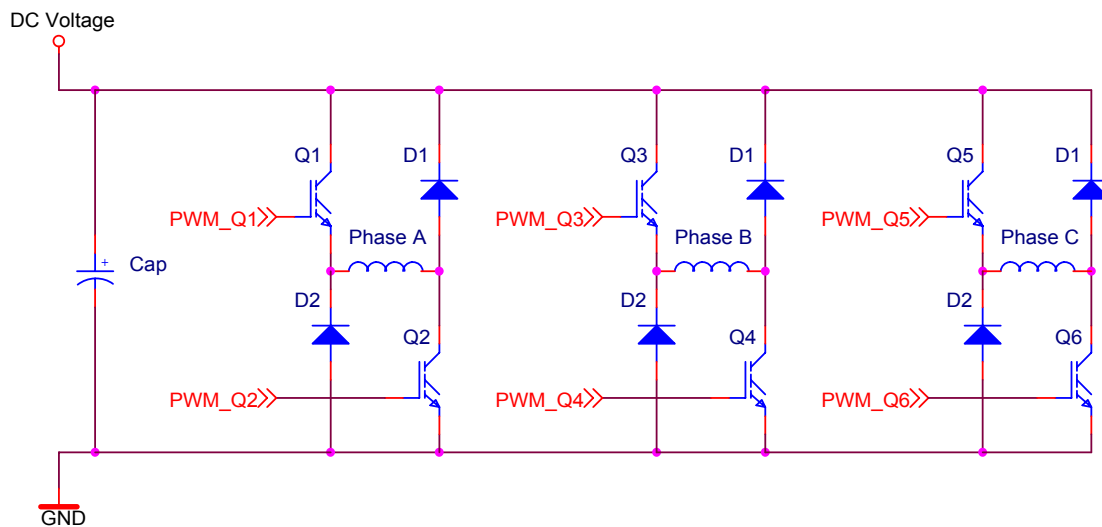

Figure 2-4. 3-Phase SR Power Stage

Figure 2-5 illustrates both soft and hard switching PWM techniques. The control signals for the upper and the lower switch of the above described power stage define the phase voltage and thus the phase current. The soft switching technique generates lower current ripple compared to the hard switching technique. Also, it produces lower acoustic noise and less EMI. Therefore, soft switching techniques are often preferred for motor operation.

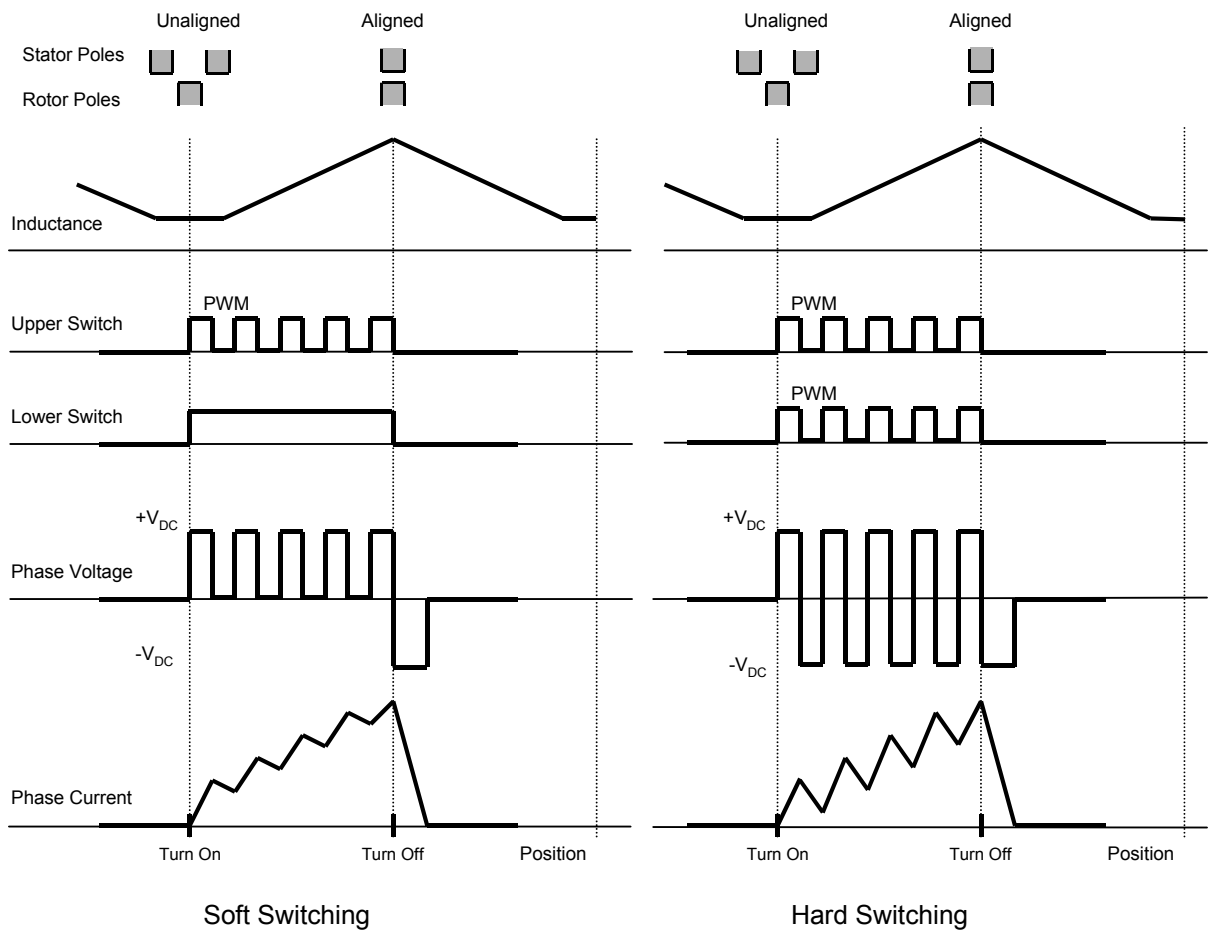

Figure 2-5. Soft Switching and Hard Switching

2.3 Control Techniques for Switched Reluctance Motors

A number of control techniques for SR motors exists. They differ in the structure of the control algorithm and in the position evaluation. The control technique described in this reference design incorporates a voltage control algorithm with the use of the position using Hall sensors.

2.3.1 Voltage Control of an SR Motor

Voltage control of an SR motor represents one of the basic control algorithms. In the algorithm, the voltage applied to the motor phases is constant during the complete sampling period of the speed control loop and the commutation of the phases is linked with the position of the rotor.

The voltage applied to the phase is controlled directly by a speed controller. The speed controller processes the speed error - the difference between the desired speed and the actual speed - and generates the desired phase voltage. The phase voltage is defined by a PWM duty cycle implemented at the DC-Bus voltage of the SR inverter. The phase voltage is constant during a complete dwell angle. The technique is illustrated in **Figure 2-6**. The current and the voltage profiles can be seen in **Figure 2-7**. The phase current is at its peak at the position when the inductance starts to increase (stator and rotor poles start to overlap) due to the change in the inductance profile.

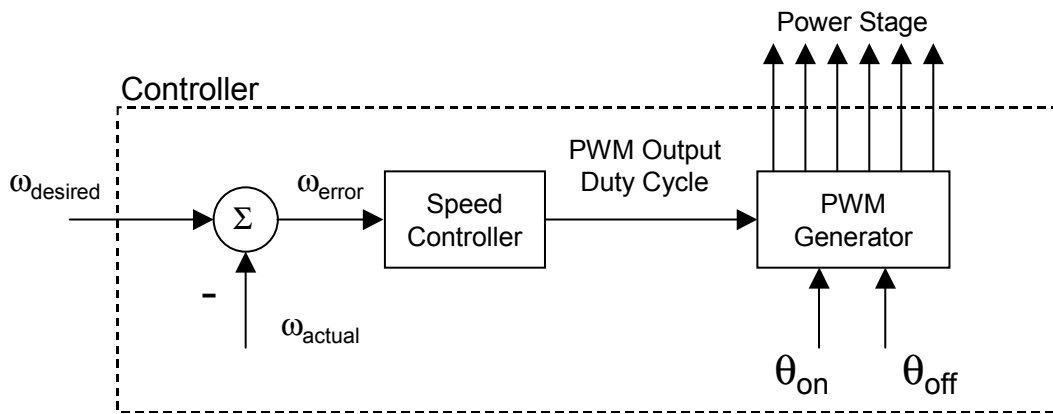

Figure 2-6. Voltage Control Technique

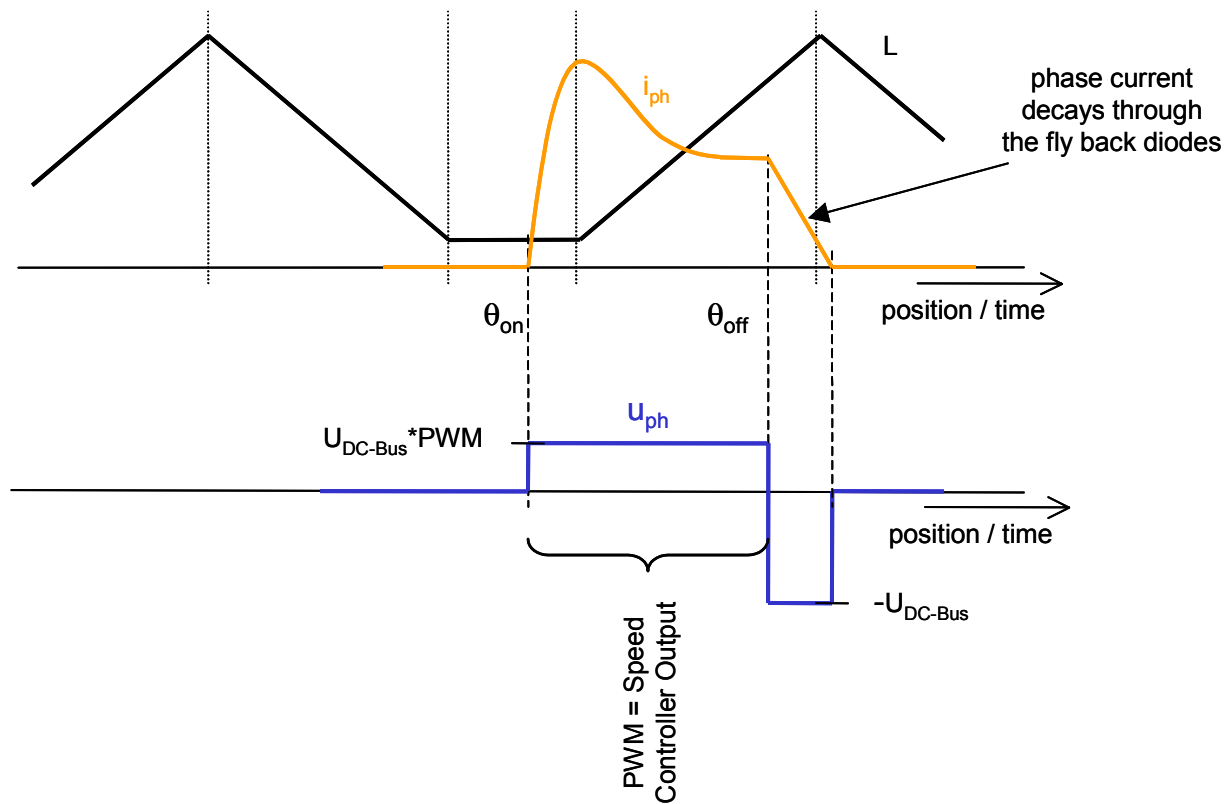

Figure 2-7. Voltage Control Technique - Voltage and Current Profiles

2.3.2 Position Sensing Using Hall Sensors

The SR motor requires position sensing for its operation. Hall sensors represent one type of a position sensor that is widely used.

The position Hall sensors consist of a segmented disk (8 segments) and three Hall sensors mounted 120° from each other. The segmented disk is mounted on the motor shaft. The number of rotor poles defines the ratio between the mechanical revolution and the electrical period. In the case of four rotor poles the ratio is 4:1. In such a configuration, the generated logic signals together provide 24 edges per one mechanical revolution, or 6 edges per one electrical period. The electrical resolution is then 60°_{el}.

The signals from the sensors are positioned in such a way, that the rising edge of the position sensor signal is in the aligned position of the individual phase:

- rising edge on sensor A for aligned position of phase A
- rising edge on sensor B for aligned position of phase B
- rising edge on sensor C for aligned position of phase C

Both the idealized profile of inductances and the alignment of the Hall sensors are illustrated in **Figure 2-8**. The figure also illustrates the selection of energized phases for the motor start-up and running, described in the following chapters.

Note that the shape of the signals does not depend on the direction of the rotation - rising edge is always in the aligned position.

2.3.3 Control Technique of SR Motors Using Hall Sensors

The control technique has to provide both reliable motor start-up from any position and then the proper commutation of the phases during motor operation. Both start-up and commutation are based on the position of the Hall sensors.

Control Theory

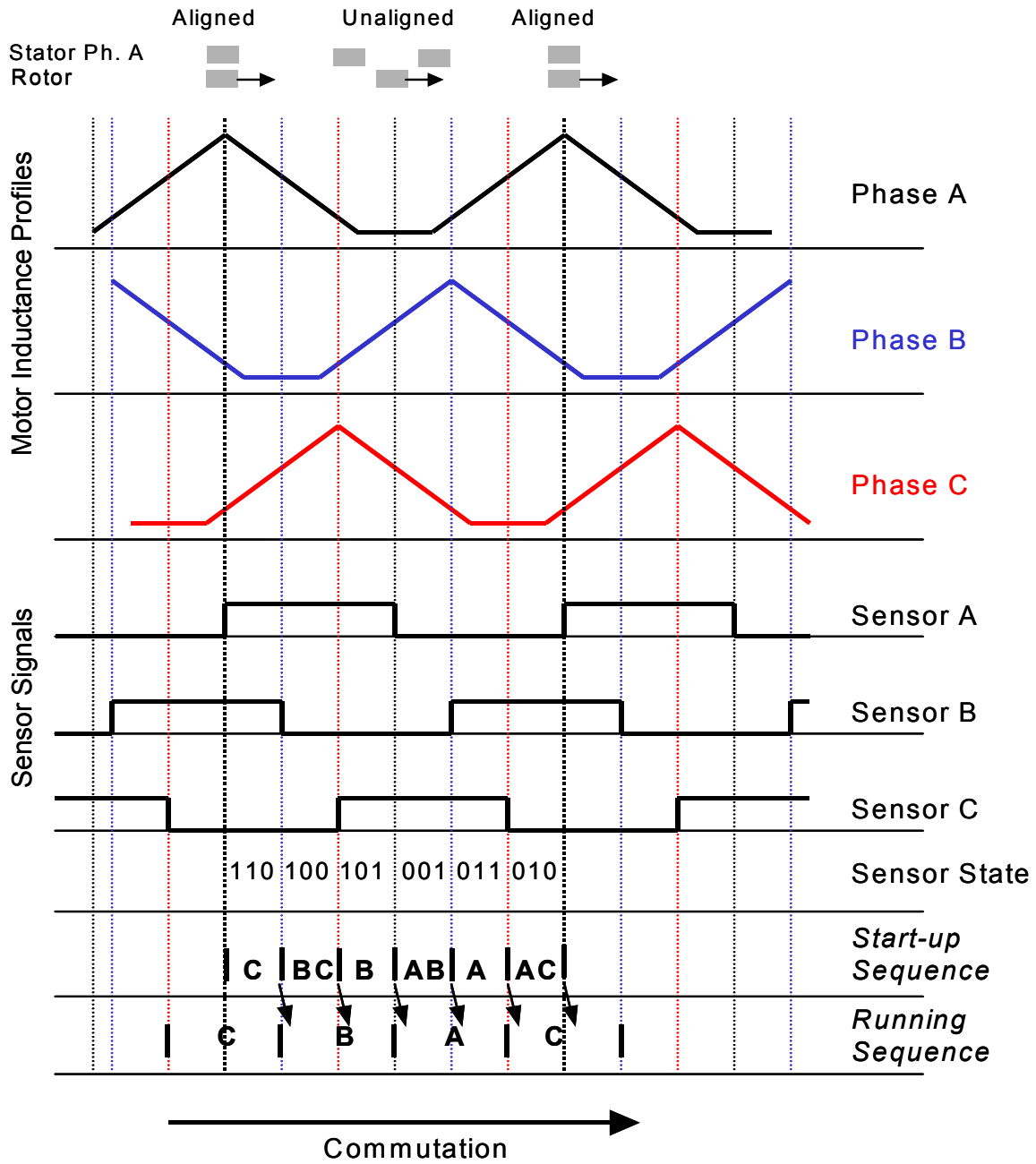

Figure 2-8. Control Technique

2.3.3.1 Start-up

The start-up algorithm provides the start-up of the motor. During the process, the state of the individual position sensors is sensed, and the phases are powered in the defined sequence in order to start the motor in the defined direction of the rotation.

The flow chart of the start-up procedure is illustrated in [Figure 2-9](#).

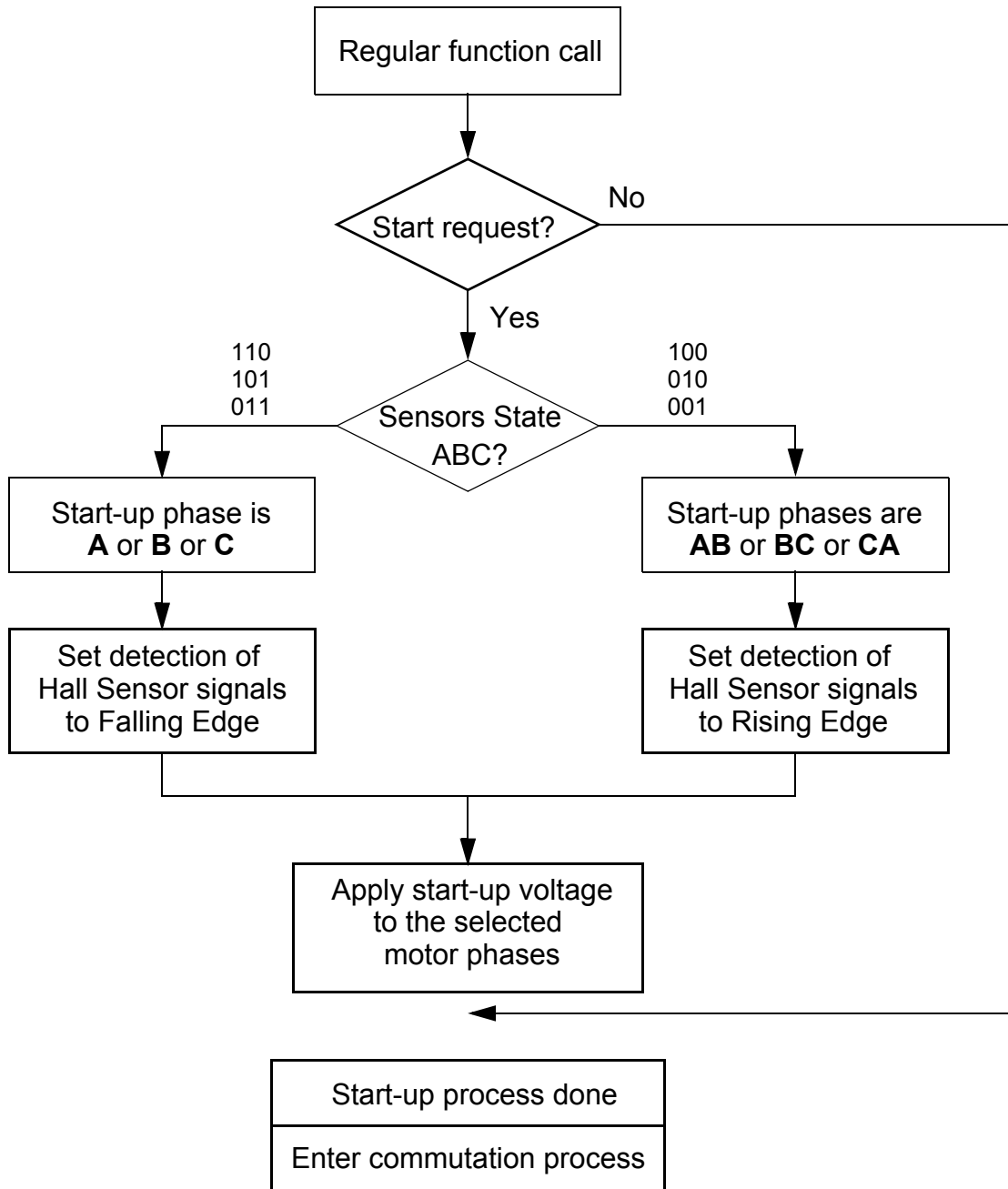

Figure 2-9. Flow Chart - Start-Up Process

During the start-up process, the start-up command is checked regularly. When the start-up command is accepted, the actual state of the sensors

is checked and the desired start-up phases are selected. The selection of the phases depends on the actual start-up position of the rotor. It is influenced by the following aspects:

- The position sensor has limited precision because of its mechanical construction. This results in the fact that the actual rotor position might be shifted a little with respect to the sensed position.
- The resolution of the sensor during stand still is electrical 60° (6 pulses per electrical period). It is too wide for a reliable determination of the single phase or two phases that should be powered first in order to start the motor.

Due to these limitations of the Hall sensors, there are some start-up positions where just one phase can be powered, and other start-up positions where two motor phases must be powered simultaneously in order to start the motor reliably. The selection of the start-up phases is defined by the torque that the individual phases can generate in the start-up position, and its relation to the Hall sensors.

As it was stated in [Section 2.2](#), when the voltage is applied to the stator phase, the motor creates torque in the direction of the increasing inductance. Note that the value of the applied start-up voltage is limited by a maximal phase current, so it must depend on the parameters of the motor.

In several states of the Hall sensors, the inductance profile is steadily rising over a whole 60°_{el} interval (see [Figure 2-8](#)). Therefore the motor is able to generate the desired start-up torque. It is sufficient to power just one phase there:

- Sensor state “110” : power phase C
- Sensor state “101” : power phase B
- Sensor state “011” : power phase A

When the appropriate voltage is applied to the selected phase, the motor starts to rotate.

In the other positions, the inductance is not steadily rising over a whole 60°_{el} interval, therefore the desired torque might not be generated there. E.g., for the 60°_{el} interval of the Hall sensors state “100”:

- Phase A generates a negative torque,
- Phase B cannot be powered alone due to the flat inductance at the beginning of the interval, causing poor torque generation there,
- Phase C cannot be powered alone due to the flat inductance at the end of the interval causing poor torque generation there. Also, the possible inaccuracy of the sensor can even cause decreasing inductance at the end of the interval generating a negative torque.

Therefore for the Hall sensors state “100”, both phases B and C need to be powered simultaneously, ensuring the generation of the correct torque for the full 60°_{el} interval.

Similarly, simultaneously powered phases are defined for the other “non definite” positions.

- Sensor state “100” : power phases B and C
- Sensor state “001” : power phases A and B
- Sensor state “010” : power phases A and C

When both phases are powered, the motor starts to move in the direction of increasing inductance. When the Hall sensors generate a rising edge, the corresponding phase needs to be turned-off, because it approaches the interval of the falling inductance (negative torque). Then only one phase stays powered.

When the motor starts to rotate in the desired direction of rotation, the start-up procedure is left and the commutation process is entered (see [Figure 2-9](#)).

2.3.3.2 Commutation

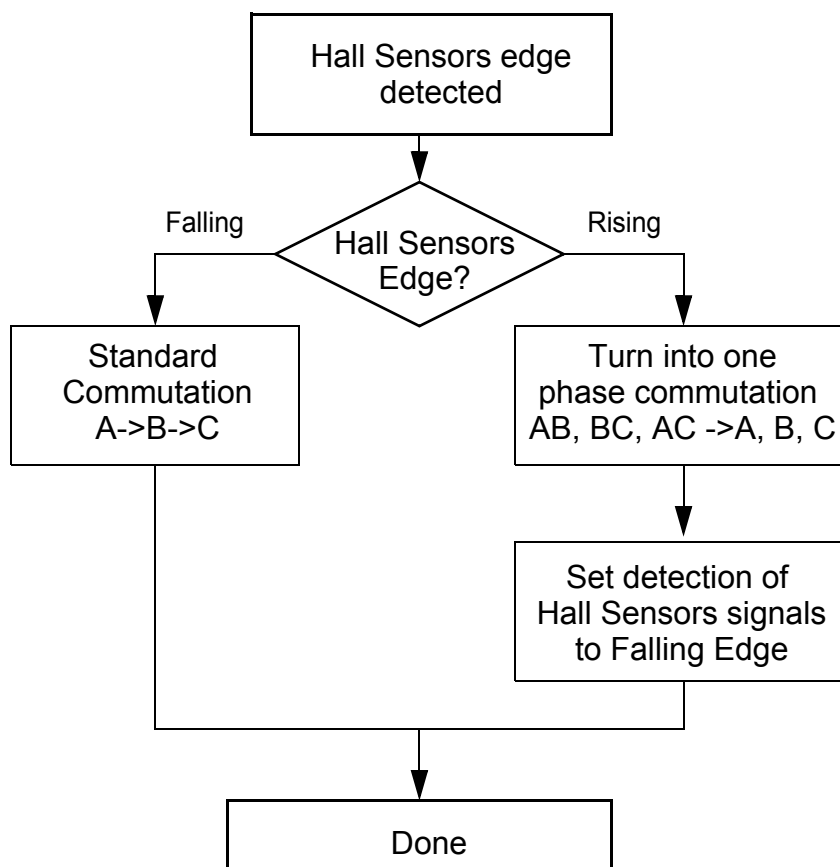

Figure 2-10. Flow Chart - Commutation Phase

Figure 2-10 illustrates the flow chart for the commutation phase. The process begins with the sensing of the edge from the Hall sensor signals. First, the polarity of the signal edge is evaluated. This is important for smooth transition between the start-up and the commutation phase. For a rising signal edge two phases were powered during the motor start-up. One of these two phases is turned-off and only one phase stays powered:

- Rising edge of sensor A: turn-off phase A, keep phase C turned-on
- Rising edge of sensor B: turn-off phase B, keep phase A turned-on
- Rising edge of sensor C: turn-off phase C, keep phase B turned-on

Then, the edge polarity detection of the Hall sensor signals is changed to the falling edge thus switching to the standard commutation process.

During the standard commutation procedure, only falling edges from the Hall sensors are detected. The turn-on and turn-off angles are directly determined by the position signals of the Hall sensors. When the falling edge on the sensor signal occurs, the corresponding phase is turned-off and the following phase in the direction of rotation is turned-on. The phases commute in the sequence C-B-A-C.

- Falling edge of sensor A: turn-off phase A, turn-on phase C
- Falling edge of sensor B: turn-off phase B, turn-on phase A
- Falling edge of sensor C: turn-off phase C, turn-on phase B

The commutation algorithm is accessed when the falling edge is sensed. The phases of the motor are sequentially powered and the motor rotates in the desired direction of rotation.

The introduced algorithm is simple, but it gives acceptable results for the considered speed range and it is a good starting point for further development of the SR algorithms. The improvement of the method can be represented by the adjustment of the turn-on and turn-off angles according to the motor speed. It is especially important for higher speeds, where the increase of the phase voltage is not possible due to the PWM saturation of 100%. The current controlled SR drive can be developed, when an inner current control loop is added. Also, the sensorless SR drive can be developed on the basis of the introduced algorithm.

Section 3. System Concept

3.1 Contents

3.2	System Outline	35
3.3	Application Description	37

3.2 System Outline

The system is designed to drive a 3-phase SR motor. The application meets the following performance specifications:

- Voltage control of an SR motor using Hall sensors
- Targeted for DSP56F805EVM
- Running on a 3-phase SR HV Motor Control Development Platform at variable line voltage 115 - 230V AC (range -15%.....+10%)
- Running on a 3-phase SR LV Motor Control Development Platform at voltage 12V DC
- Control technique incorporates
 - voltage SRM control with speed-closed loop
 - one direction of rotation
 - motoring mode
 - start from any motor position without rotor alignment
 - minimal speed 700 rmp
 - maximal speed 2500rpm for a HV SR motor at the input power line 230V AC
 - maximal speed 1500rpm for a HV SR motor at the input power line 115V AC

System Concept

- maximal speed 1500rpm for a LV SR motor at the input power line 12V DC
- Manual interface (Start/Stop switch, Up/Down push button control, Led indication)
- PC master software control interface (motor start/stop, speed set-up)
- PC master software monitor
 - PC master software graphical control page (required speed, actual motor speed, PC master remote control mode, start/stop status, drive fault status, DC-Bus voltage level, identified power stage boards, system status)
 - PC master software speed scope (observes actual and desired speeds)
- Power stage identification
- DC-Bus over-voltage, DC-Bus under-voltage, DC-Bus over-current and over-temperature fault protection

The introduced SR drive is designed to power both low voltage and high voltage SR motors equipped with Hall sensors. The motors have the following specifications:

Table 3-1. Specifications of the Motor and Hall Sensors

Motor Specification:	eMotor Type:	Three - Phase SR Motor 6/4 (Stator / Rotor) Poles	
	Speed Range:	< 5000 rpm	
	Nominal Voltage:	High-Voltage Motor	300V
		Low-Voltage Motor	10V
	Nominal Current:	High-Voltage Motor	3 x 1.2A
		Low-Voltage Motor	3 x 28.5A

Table 3-1. Specifications of the Motor and Hall Sensors

Position Sensor Specification:	Sensor Type:	3-Phase Hall sensors
	No. of Disc Segments:	8
	Sensor layout:	sensors distributed at 60 ^o _{mech} angles to each other

3.3 Application Description

For the drive a standard system concept is chosen (see **Figure 3-1**). The system incorporates the following hardware parts:

- **Three-phase SR high-voltage development platform** (a high voltage power stage with an optoisolation board, a high voltage SR motor with an attached brake)
or **three-phase SR low-voltage development platform** (a low voltage power stage, a low voltage SR motor with an attached brake)
- Feedback sensors: position (Hall sensors), DC-Bus voltage, DC-Bus current, temperature
- DSP controller

The DSP runs the main control algorithm. According to the user interface input and feedback signals it generates 3-phase PWM output signals for the SR motor inverter.

The drive can basically be controlled in two different operational modes:

- In the Manual operational mode the required speed is set by a Start/Stop switch and Up and Down push buttons.
- In the PC master software operational mode, the required speed is set by the PC master software.

System Concept

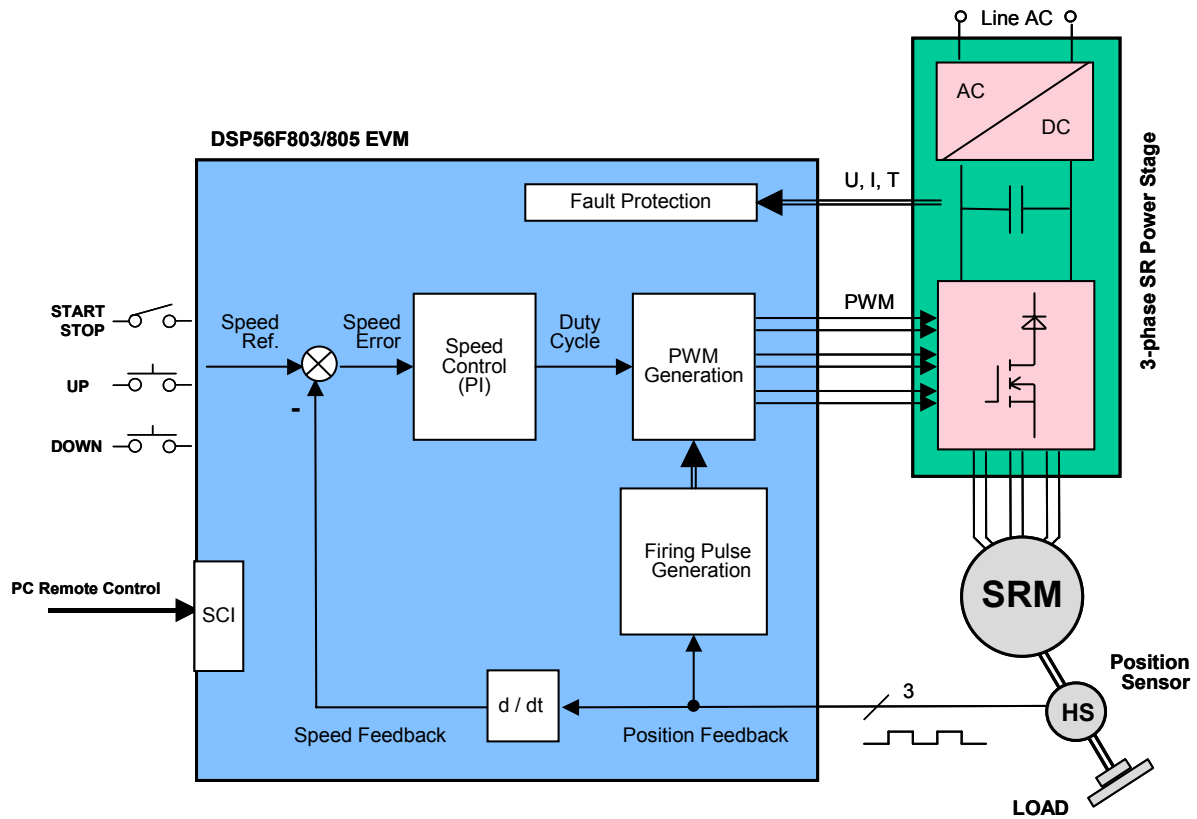

Figure 3-1. System Concept

After RESET the drive is initialized and it automatically enters the MANUAL operational mode. Note, the PC master software can only take over control when the motor is stopped.

When the start command is detected (using the Start/Stop switch or the PC master software button “Start”) and no fault is pending, the application can be started. First, the start-up sequence is performed. The state of the Hall sensors position signals is sensed and the individual motor phases are powered in order to start the motor in the requested direction of rotation. When the motor starts to rotate, the commutation process is enabled. The edges of the Hall sensors’ position signals are captured by the Input Capture function of the DSP on-chip Quadrature Timer module. Based on these captured signals, the switching pattern for the PWM control signals is determined.

The actual speed of the motor is determined by the Hall sensor signals. The reference speed is calculated according to the control signals (Start/Stop switch, Up/Down push buttons) and the PC master software commands (in the case of the control by the PC master software). The acceleration/deceleration ramp is implemented. The comparison between the reference speed and the measured speed gives a speed error. Based on the speed error, the speed controller generates the desired PWM duty cycle. Finally, according to the determined switching pattern and the calculated duty cycle, the DSP on-chip PWM module generates the PWM signals for the SR motor power stage.

The DC-Bus voltage, the DC-Bus current and the power stage temperature are measured during the control process. The measurements are used for DC-Bus over-voltage, DC-Bus under-voltage, DC-Bus over-current and over-temperature protection of the drive. The DC-Bus under-voltage and over-temperature protection are performed by the software, while the DC-Bus over-current and the DC-Bus over-voltage fault signals utilize the Fault inputs of the DSP on-chip PWM module. If any of the above mentioned faults occur, the PWM outputs are disabled in order to protect the drive. The fault state can only be exited when the fault conditions have disappeared and the Start/Stop switch is moved to the STOP position.

Each power stage contains a simple module, generating a logic signal sequence, unique for that type of power stage. During the initialization of the application, this sequence is read and evaluated according to the decoding table. If the correct SR power stage is not identified, the fault "Wrong Power Stage" disables any drive operation.



Section 4. Hardware

4.1 Contents

4.2	Hardware Implementation.	41
4.2.1	3-Phase SR Low-Voltage Platform.	42
4.2.2	3-Phase SR High-Voltage Platform	43
4.3	DSP56F805EVM Control Board	45
4.4	3-Phase Switched Reluctance High-Voltage Power Stage . . .	49
4.5	3-Phase Switched Reluctance Low-Voltage Power Stage . . .	51
4.6	Optoisolation Board	53
4.7	Motor-Brake Specifications.	55

4.2 Hardware Implementation

As already stated, the application runs on the Motorola motor control DSPs using the DSP EVM Board and a dedicated 3-Phase SR platform.

The application is controlled by the Motorola DSP56F805.

The application can run on both the following motor platforms:

- [3-Phase SR Low-Voltage Platform](#)
- [3-Phase SR High-Voltage Platform](#)

The application HW setup is shown in [Figure 4-1](#) and [Figure 4-2](#). The application software is identical for both SR platforms. The board identification message is used to recognize the connected platform and to chose the valid set of applications parameters.

Detailed application HW setup can be found in the [Figure 6](#).

Dedicated User's Manuals describe the individual boards in detail. The User's Manual incorporates a schematic of the board, a description of individual function blocks and a bill of materials of the board. The individual boards can be ordered from Motorola as standard products. The following chapters illustrate the configuration of the both the SR high-voltage platform and the SR low-voltage platform, together with references to the documentation. Descriptions of all the mentioned boards and documents can be found at: <http://e-www.motorola.com/>

4.2.1 3-Phase SR Low-Voltage Platform

The system configuration is shown in [Figure 4-1](#).

All the system parts are supplied and documented according to the following references.

- U1 - Controller Board for DSP56F805:
 - supplied as: DSP56805EVM
described in: DSP56F805EVMUM/D DSP Evaluation Module User's Manual
- U2 - 3-Phase SR Low-Voltage Power Stage
 - supplied as: ECLOVSR
described in: MEMC3PSRLVPSUM/D Motorola Embedded Motion Control 3-Phase Switched Reluctance Low-Voltage Power Stage User's Manual
- MB1 - Motor-Brake SR40N + SG40N
 - supplied as: ECMTRLOVSR

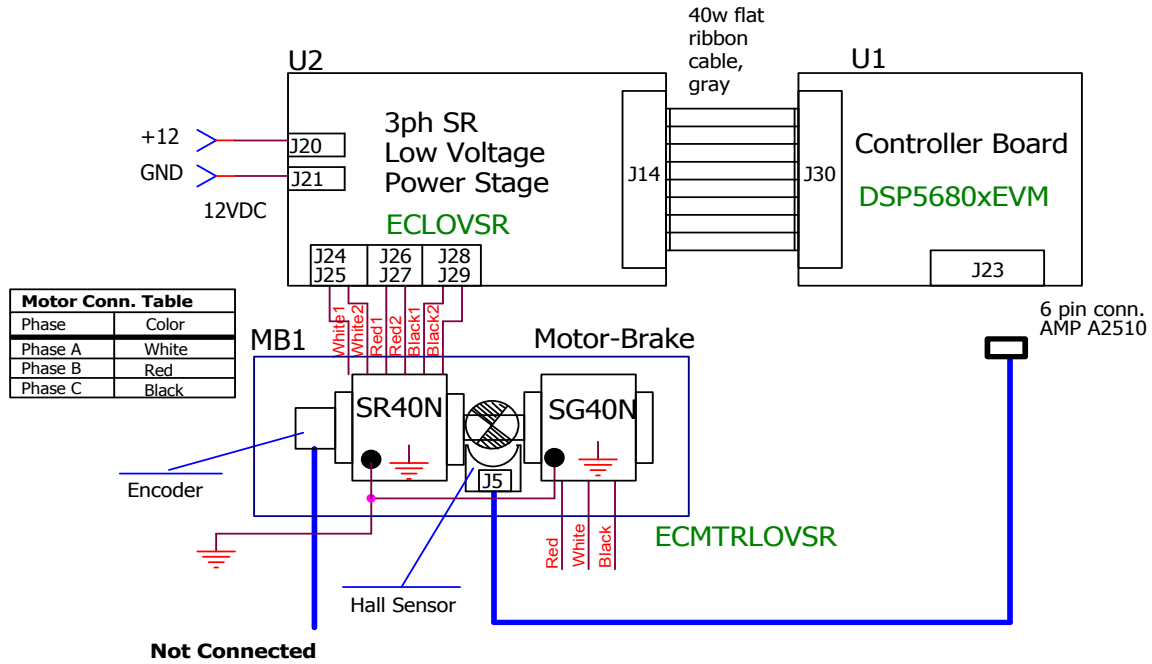

Figure 4-1. 3-Phase SR Low-Voltage Platform Configuration

4.2.2 3-Phase SR High-Voltage Platform

The system configuration is shown in [Figure 4-2](#).

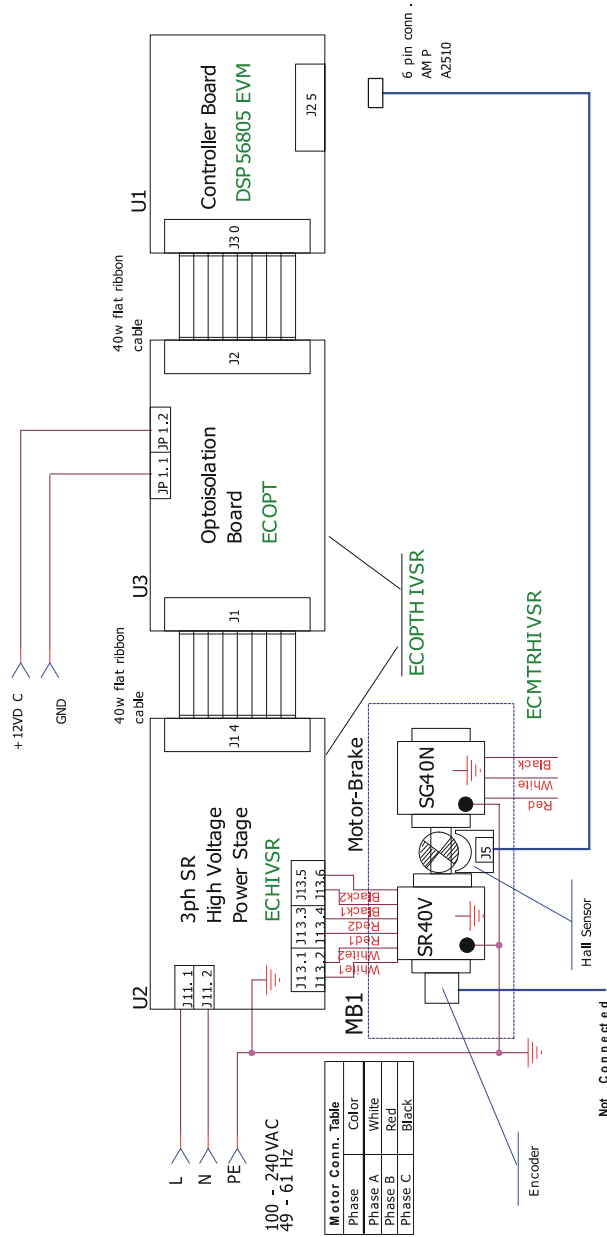

Figure 4-2. 3-Phase SR High-Voltage Platform Configuration

All the system parts are supplied and documented according to the following references:

- U1 - Controller Board for DSP56F805:
 - supplied as: DSP56805EVM
described in: DSP56F805EVMUM/D DSP Evaluation Module Hardware User's Manual
- U2 - 3-Phase SR High-Voltage Power Stage
 - supplied in kit with Optoisolation Board as: ECOPTHIVSR
 - described in: MEMC3PSRHVPSUM/D Motorola Embedded Motion Control 3-Phase Switched Reluctance High-Voltage Power Stage User's Manual
- U3 - Optoisolation Board
 - supplied with 3 ph SR High Voltage Power Stage as: ECOPTHIVSR
 - or supplied separately as: ECOPT - optoisolation board
 - described in: MEMCOBUM/D Optoisolation board User's Manual
- MB1 Motor-Brake SR40V + SG40N
 - supplied as: ECMTRHIVSR

WARNING: *It is strongly recommended to use an opto-isolation (optocouplers and optoisolation amplifiers) during development time to avoid electric shock and any damage to the development equipment.*

4.3 DSP56F805EVM Control Board

The DSP56F805EVM facilitates the evaluation of various features present in the DSP56F805 part. The DSP56F805EVM can be used to develop real-time software and hardware products based on the DSP56F805. The DSP56F805EVM provides the features necessary for a user to write and debug software, demonstrate the functionality of that software and interface with the customer's application-specific device(s). The DSP56F805EVM is flexible enough to allow a user to fully exploit the

DSP56F805's features to optimize the performance of their product, as shown in [Figure 4-3](#)

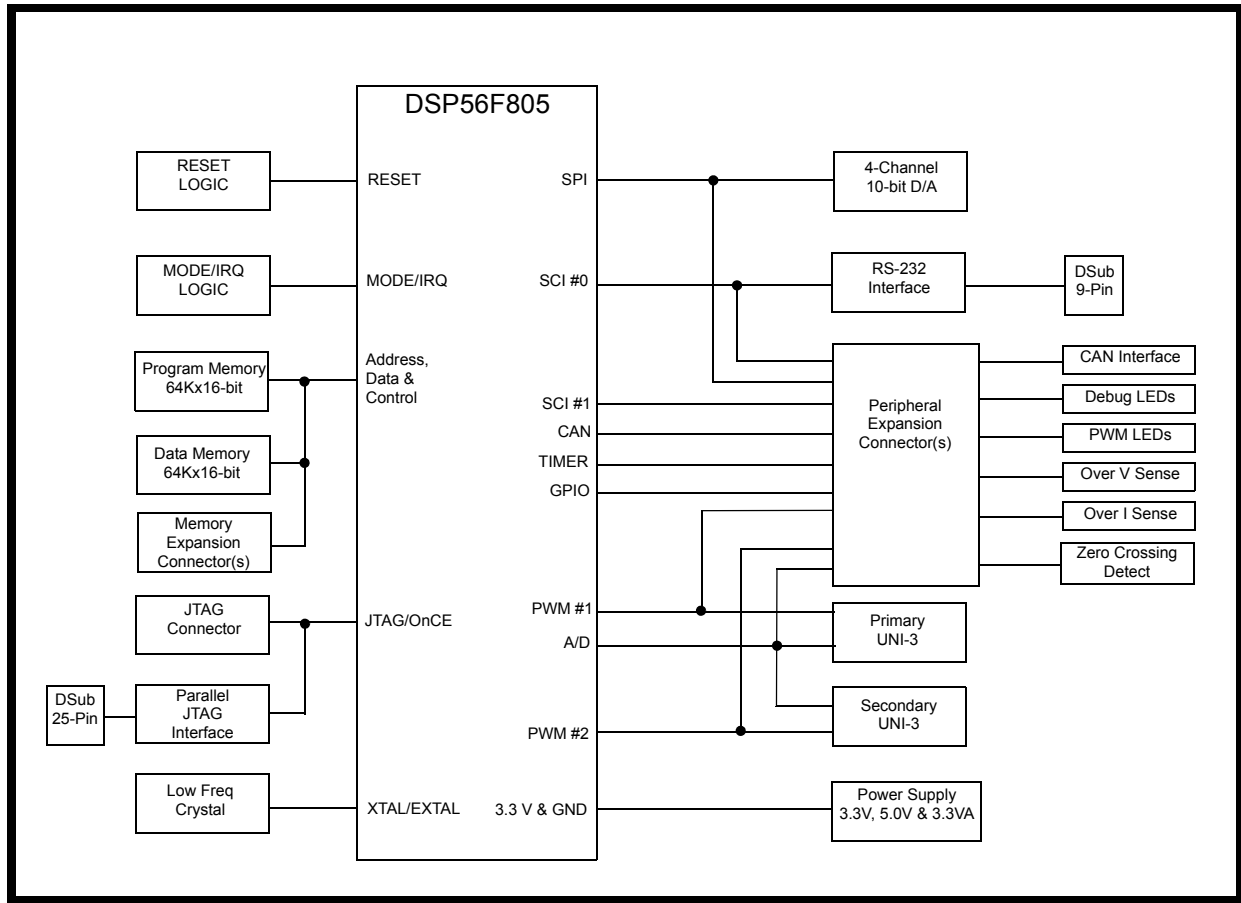

Figure 4-3. Block Diagram of the DSP56F805EVM

4.3.1 DSP56F805EVM Configuration Jumpers

Eighteen jumper groups, (JG1-JG18), shown in [Figure 4-4](#), are used to configure various features on the DSP56F805EVM board. [Table 4-1](#) describes the default jumper group settings.

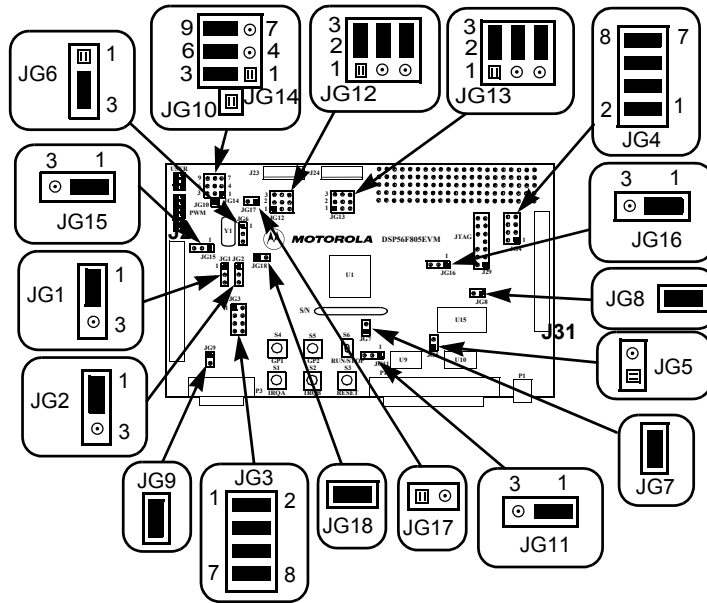

Figure 4-4. DSP56F805EVM Jumper Reference

Table 4-1. DSP56F805EVM Default Jumper Options

Jumper Group	Comment	Jumpers Connections
JG1	PD0 input selected as a high	1-2
JG2	PD1 input selected as a high	1-2
JG3	Primary UNI-3 serial selected	1-2, 3-4, 5-6 & 7-8
JG4	Secondary UNI-3 serial selected	1-2, 3-4, 5-6 & 7-8
JG5	Enable on-board Parallel JTAG Host Target Interface	NC
JG6	Use on-board crystal for DSP oscillator input	2-3
JG7	Selects DSP's Mode 0 operation upon exit from reset	1-2
JG8	Enable on-board SRAM	1-2
JG9	Enable RS-232 output	1-2
JG10	Secondary UNI-3 Analog Temperature Input unused	1-2
JG11	Use Host power for Host Target Interface	1-2

Table 4-1. DSP56F805EVM Default Jumper Options (Continued)

Jumper Group	Comment	Jumpers Connections
JG12	Primary Encoder Input Selected	2-3, 5-6 & 8-9
JG13	Secondary Encoder Input Selected	2-3, 5-6 & 8-9
JG14	Primary UNI-3 3-Phase Current Sense Selected as Analog Inputs	2-3, 5-6 & 8-9
JG15	Primary UNI-3 Phase A Over-Current Selected for FAULTA1	1-2
JG16	Secondary UNI-3 Phase B Over-Current Selected for FAULTB1	1-2
JG17	CAN termination unselected	NC
JG18	Use on-board crystal for DSP oscillator input	1-2

An interconnection diagram is shown in [Figure 4-5](#) for connecting the PC and the external 12V DC power supply to the DSP56F805EVM board.

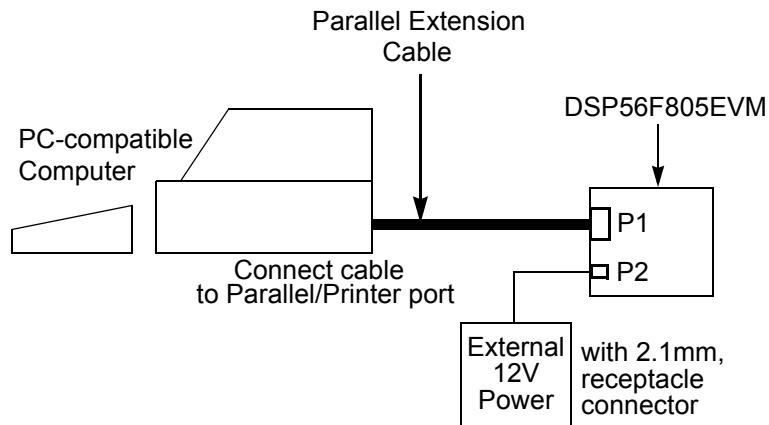

Figure 4-5. Connecting the DSP56F805EVM Cables

Perform the following steps to connect the DSP56F805EVM cables:

1. Connect the parallel extension cable to the Parallel port of the host computer.
2. Connect the other end of the parallel extension cable to P1, shown in [Figure 4-5](#), on the DSP56F805EVM board. This provides the connection which allows the host computer to control the board.

3. Make sure that the external 12V DC, 4.0A power supply is not plugged into a 120V AC power source.
4. Connect the 2.1mm output power plug from the external power supply into P2, shown in [Figure 4-5](#), on the DSP56F805EVM board.
5. Apply power to the external power supply. The green Power-On LED, LED10, will illuminate when power is correctly applied.

4.4 3-Phase Switched Reluctance High-Voltage Power Stage

Motorola's embedded motion control series high-voltage (HV) switched reluctance (SR) power stage is a 180 watt (1/4 horsepower), 3-phase power stage that will operate off of dc input voltages from 140 volts to 230 volts and ac line voltages from 100 volts to 240 volts. In combination with one of Motorola's Embedded Motion Control Series control boards and an optoisolation board, it provides a software development platform that allows algorithms to be written and tested, without the need to design and build a power stage. It supports a wide variety of algorithms for controlling switched reluctance motors.

Input connections are made via 40-pin ribbon cable connector J14. Power connections to the motor are made on output connector J13. Phase A, phase B, and phase C are labeled Ph. A, Ph. B, Ph. C on the board. Power requirements are met with a single external 140-volt to 230-volt dc power supply or an ac line voltage. Either input is supplied through connector J11. Current measuring circuitry is set up for 2.93 amps full scale. Both bus and phase leg currents are measured. A cycle-by-cycle overcurrent trip point is set at 2.69 amps.

The HV SR power stage has both a printed circuit board and a power substrate.

The printed circuit board contains IGBT gate drive circuits, analog signal conditioning, low-voltage power supplies, power factor control circuitry, and some of the large passive power components. This board also has a MC68HC705JJ7 microcontroller used for board configuration and identification. All of the power electronics that need to dissipate heat are mounted on the power substrate. This substrate includes the power

IGBTs, brake resistors, current-sensing resistors, a power factor correction MOSFET, and temperature sensing diodes. **Table 4-6** shows a block diagram.

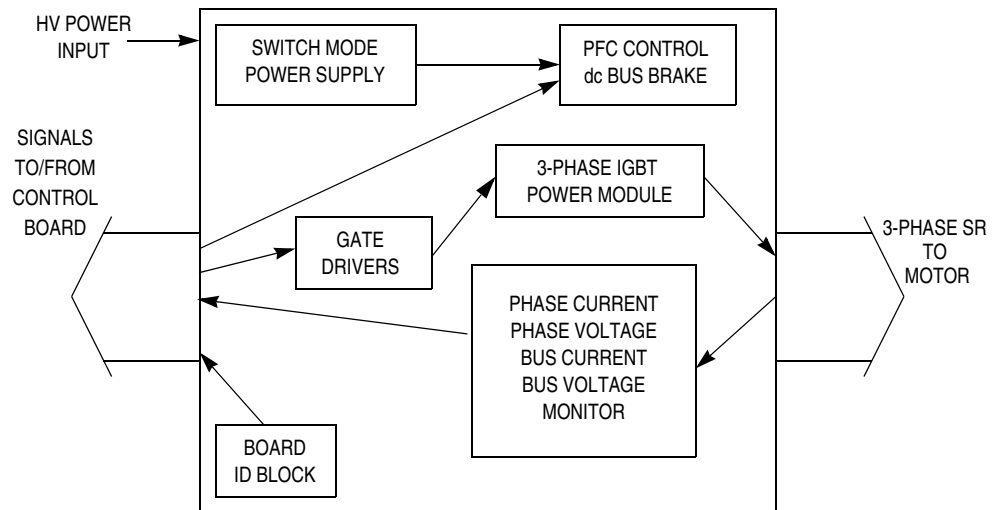

Figure 4-6. Block Diagram

The electrical characteristics in **Table 4-2** apply to operation at 25 degrees C with a 160-Vdc supply voltage.

Table 4-2. Electrical Characteristics

Characteristic	Symbol	Min	Typ	Max	Units
dc input voltage	V _{dc}	140	160	230	V
ac input voltage	V _{ac}	100	208	240	V
Quiescent current	I _{CC}	—	70	—	mA
Min logic 1 input voltage	V _{IH}	2.0	—	—	V
Max logic 0 input voltage	V _{IL}	—	—	0.8	V
Input resistance	R _{In}	—	10 kΩ	—	
Analog output range	V _{Out}	0	—	3.3	V
Bus current sense voltage	I _{Sense}	—	563	—	mV/A
Bus voltage sense voltage	V _{Bus}	—	8.09	—	mV/V
Peak output current	I _{PK}	—	—	2.8	A
Brake resistor dissipation (continuous)	P _{BK}	—	—	50	W
Brake resistor dissipation (15 sec pk)	P _{BK(Pk)}	—	—	100	W
Total power dissipation	P _{diss}	—	—	85	W

4.5 3-Phase Switched Reluctance Low-Voltage Power Stage

Motorola's embedded motion control series low-voltage (LV) switched reluctance (SR) power stage operates from a nominal 12-volt motor supply, and delivers up to 30 amps of rms motor current from a dc bus that can deliver peak currents up to 46 amps. In combination with one of Motorola's embedded motion control series control boards, it provides a software development platform that allows algorithms to be written and tested, without the need to design and build a power stage. It supports a wide variety of algorithms for controlling switched reluctance motors.

Input connections are made via 40-pin ribbon cable connector J14. Power connections to the motor are made with fast-on connectors J24–J29. They are located along the back edge of the top board, and are labeled Phase AB, Phase BT, Phase BB, etc. Power requirements are

met with a 12-volt power supply that has a 10- to 16-volt tolerance. Fast-on connectors J20 and J21 are used for the power supply. J20 is labeled +12V and is located at the back left corner of the top board. J21 is labeled 0V and is located at the front left corner of the top board. Current measuring circuitry is set up for 50 amps full scale. Both bus and phase leg currents are measured. A cycle-by-cycle overcurrent trip point is set at 46 amps.

The LV SR power stage has both a printed circuit board and a power substrate. The printed circuit board contains MOSFET gate drive circuits, analog signal conditioning, low-voltage power supplies, and some of the large passive power components. This board also has a 68HC705JJ7 microcontroller used for board configuration and identification. All of the power electronics that need to dissipate heat are mounted on the power substrate. This substrate includes the power MOSFETs, brake resistors, current-sensing resistors, bus capacitors, and temperature sensing diodes. **Table 4-7** shows a block diagram.

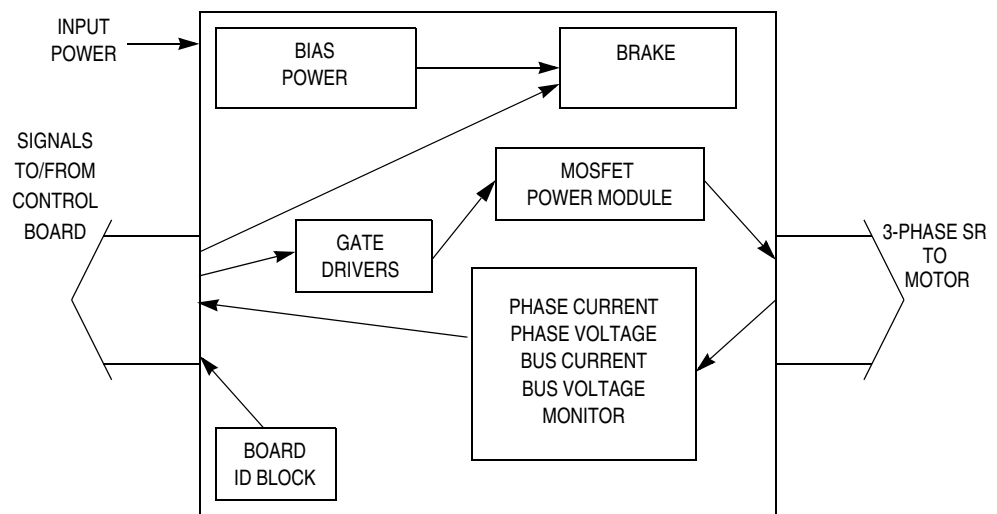

Figure 4-7. Block Diagram

The electrical characteristics in [Table 4-3](#) apply to operation at 25 degrees C with a 160-Vdc supply voltage.

Table 4-3. Electrical Characteristics

Characteristic	Symbol	Min	Typ	Max	Units
Motor Supply Voltage	V _{dc}	10	12	16	V
Quiescent current	I _{CC}	—	175	-	mA
Min logic 1 input voltage	V _{IH}	2.0	—	—	V
Max logic 0 input voltage	V _{IL}	—	—	0.8	V
Analog output range	V _{Out}	0	—	3.3	V
Bus current sense voltage	I _{Sense}	—	33	—	mV/A
Bus voltage sense voltage	V _{Bus}	—	60	—	mV/V
Peak output current (300 ms)	I _{PK}	—	—	46	A
Brake resistor dissipation (continuous)	P _{BK}	—	—	50	W
Brake resistor dissipation (15 sec pk)	P _{BK(PK)}	—	—	100	W
Total power dissipation	P _{diss}	—	—	85	W
Continuous Output Current	I _{RMS}	—	—	35	A

4.6 Optoisolation Board

Motorola's embedded motion control series optoisolation board links signals from a controller to a high-voltage power stage. The board isolates the controller, and peripherals that may be attached to the controller, from dangerous voltages that are present on the power stage. The optoisolation board's galvanic isolation barrier also isolates control signals from high noise in the power stage and provides a noise-robust systems architecture.

Signal translation is virtually one-for-one. Gate drive signals are passed from the controller to the power stage via high-speed, high dv/dt, digital optocouplers. Analog feedback signals are passed back through

HCNR201 high-linearity analog optocouplers. Delay times are typically 250 ns for digital signals, and 2 μ s for analog signals. Grounds are separated by the optocouplers' galvanic isolation barrier.

Both input and output connections are made via 40-pin ribbon cable connectors. The pin assignments for both connectors are the same. For example, signal PWM_AT appears on pin 1 of the input connector and also on pin 1 of the output connector. In addition to the usual motor control signals, an MC68HC705JJ7CDW serves as a serial link, which allows controller software to identify the power board.

Power requirements for the controller side circuitry are met with a single external 12-Vdc power supply. Power for power stage side circuitry is supplied from the power stage through the 40-pin output connector.

The electrical characteristics in [Table 4-4](#) apply to operation at 25°C, and a 12-Vdc power supply voltage.

Table 4-4. Electrical Characteristics

Characteristic	Symbol	Min	Typ	Max	Units	Notes
Power Supply Voltage	Vdc	10	12	30	V	
Quiescent Current	I _{CC}	70 ⁽¹⁾	200 ⁽²⁾	500 ⁽³⁾	mA	dc/dc converter
Min Logic 1 Input Voltage	V _{IH}	2.0	—	—	V	HCT logic
Max Logic 0 Input Voltage	V _{IL}	—	—	0.8	V	HCT logic
Analog Input Range	V _{In}	0	—	3.3	V	
Input Resistance	R _{In}	—	10	—	k Ω	
Analog Output Range	V _{Out}	0	—	3.3	V	
Digital Delay Time	t _{DDLY}	—	0.25	—	μ s	
Analog Delay Time	t _{ADLY}	—	2	—	μ s	

1. Power supply powers optoisolation board only.
2. Current consumption of optoisolation board plus DSP EMV board (powered from this power supply)
3. Maximum current handled by dc/dc converters

4.7 Motor-Brake Specifications

The SR Motor Brake set incorporates a 3-Phase SR Motor and attached BLDC motor brake. The detailed specifications are listed in [Table 4-5](#).

The SR motor has six stator poles and four rotor poles. This combination yields 12 strokes (or pulses) per single mechanical revolution. The SR motor is characterized by a dedicated inductance profile. The motor inductance profile as a function of mechanical position is shown in [Figure 4-8](#). The mechanical angle 90°_{mech} corresponds to one electrical period of the stroke. The presented profile was used for the determination of the advanced commutation angle.

On the motor brake shaft, a position encoder and position Hall sensor are attached. They allow position sensing if it is required by the control algorithm. The introduced drive uses the Encoder for the position determination.

Table 4-5. Motor - Brake Specifications

Set Manufacturer	EM Brno, Czech Republic		
Motor Specification:	eMotor Type:	SR40V (3-Phase SR Motor)	SR40N (3-Phase SR Motor)
	Stator / Rotor Poles:	6/4	6/4
	Speed Range:	< 5000 rpm	<5000 rpm
	Nominal Voltage:	3 x 300V	3 x 10V
	Nominal Current:	1.2A	28,5A
Brake Specification:	Brake Type	SG40N 3-Phase BLDC Motor	SG40N 3-Phase BLDC Motor
	Nominal Voltage:	3 x 27V	3 x 27V
	Nominal Current:	2.6 A	2.6 A
Position Sensor	Type	Hall Effect	Hall Effect
	Pulses per Revolution	12	12

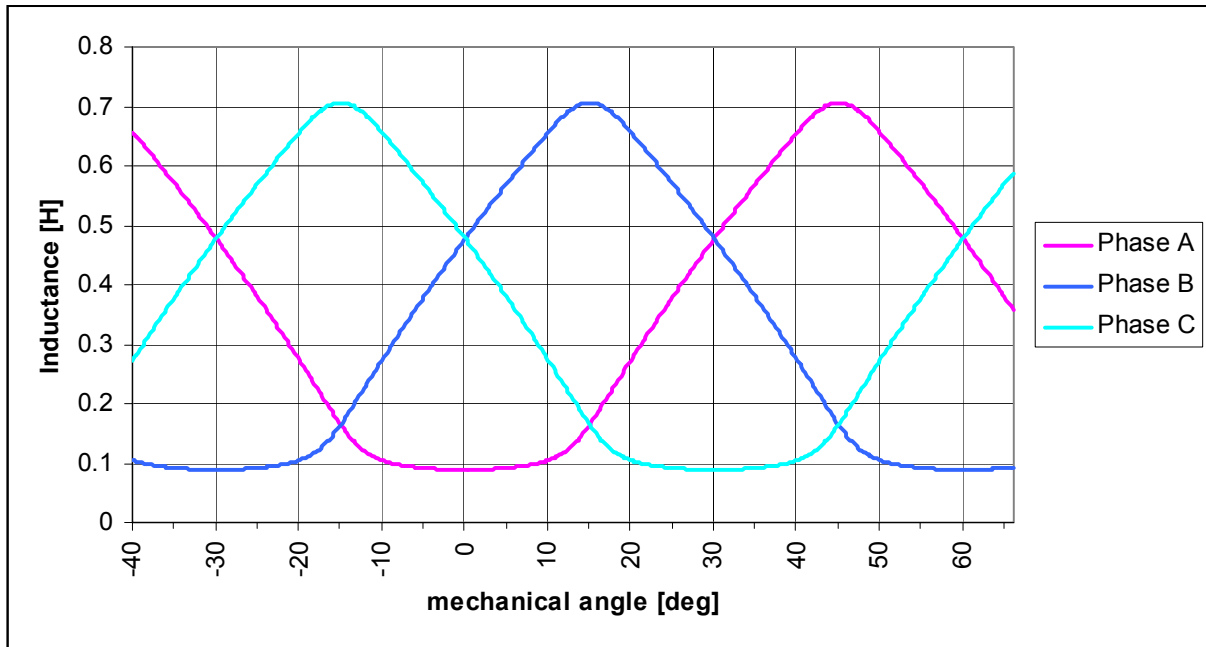

Figure 4-8. Inductance Characteristic

Section 5. Software Design

5.1 Contents

5.2	Introduction	57
5.3	Data Flow	58
5.3.1	Acceleration Ramp	60
5.3.2	Commutation Calculation	60
5.3.3	Velocity Calculation	61
5.3.4	Speed Controller	61
5.3.5	PWM Generation	62
5.4	Software Implementation	62
5.4.1	Initialization.	65
5.4.2	Interrupts	66
5.4.3	Scheduler	68
5.5	Implementation Notes	69
5.5.1	Scaling of Quantities	69
5.5.2	Voltages Scaling.	70
5.5.3	Speed Scaling	70
5.5.4	Duty-Cycle Scaling	71
5.5.5	Velocity calculation.	71

5.2 Introduction

This section describes the design of the software blocks of the drive. The software will be described in terms of

- Control Algorithm Data Flow
- Software Implementation

5.3 Data Flow

The control algorithm of the close loop SR drive is described in [Figure 5-1](#).

The desired speed is set either using the manual interface, or by the PC master software. The speed command is generated according to the defined acceleration ramp of the motor. The actual speed is calculated from the time captured between the detected edges of the Hall sensors. The speed controller utilizes both the speed command and the actual speed and generates the desired PWM duty cycle.

When the edge from the Hall sensor signal is detected, a new commutation pattern for the motor phases is generated. The output voltage is then generated according the desired duty cycle, the actual DC-Bus voltage and the new commutation pattern using the DSP on-chip PWM module.

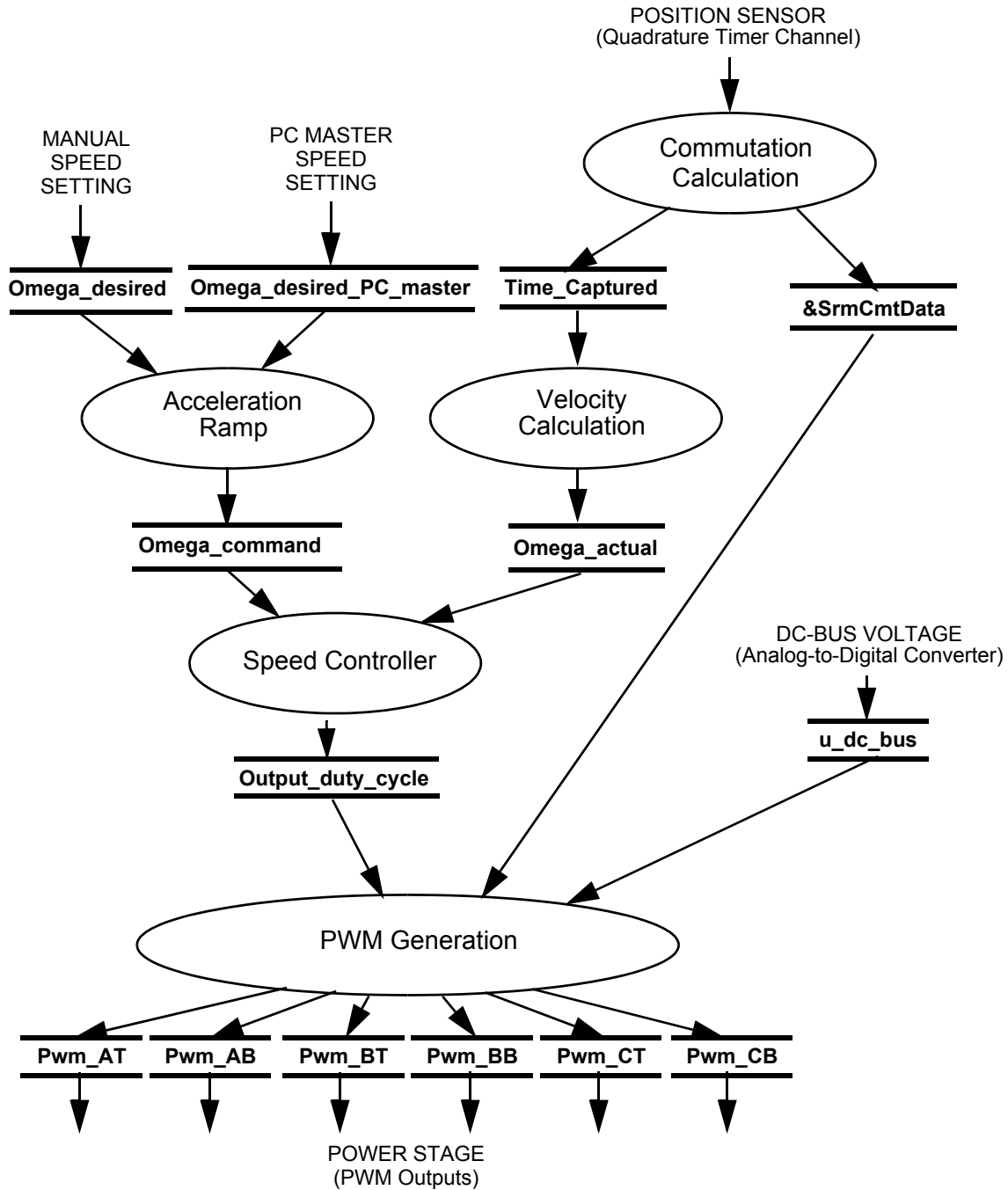

Figure 5-1. Data Flow

The individual processes are described in detail in the following sections.

5.3.1 Acceleration Ramp

The process calculates the actual speed command based on the desired speed according to the acceleration / deceleration ramp. The desired speed is controlled either manually using the push buttons (in the case of manual operational mode), or by the PC master software (in the case of PC master software operational mode).

5.3.2 Commutation Calculation

The process services the position Hall sensor signals. It generates PWM commutation patterns and also captures the time between the last two edges of the Hall sensor signals.

The Hall sensors generate a stream of pulses that are directed to the on-chip Quadrature Timer module. Since the position sensor utilizes three Hall sensors, three channels of the Quadrature Timer are used. The Input Capture function of the Quadrature Timer invokes the calculation of the process when the correct edge of the Hall sensor appears.

The DSP on-chip PWM module is used in the mode of generation of independent output signals that can be controlled either by software or by the PWM module.

The commutation technique distinguishes three following cases:

- When the PWM output needs to be modulated, the PWM generator controls the channel directly
- When the PWM output needs to be switched to the inactive state (0), the software output control of the corresponding PWM channel is handed over and the channel is turned off manually
- When the PWM output needs to be switched to the active state (1), the software output control of the corresponding PWM channel is handed over and the channel is turned on manually

The on-chip PWM module enables control of the outputs of the PWM module either by the PWM generator, or using the software. Setting the output control enable bit, OUTCTLx, enables software to drive the PWM

outputs instead of the PWM generator. In the independent mode, with $OUTCTLx = 1$, the output bit $OUTx$ controls the PWMx channel. Setting or clearing the $OUTx$ bit activates or deactivates the PWMx output. The $OUTCTLx$ and $OUTx$ bits are in the PWM output control register.

The control technique requires the preparation of the output control register. For the calculation of the $OUTCTLx$ and $OUTx$ bits in the PWM output control register, a dedicated commutation algorithm, 3-Phase SR Motor Commutation Handler for H/W Configuration 2-Switches-per-Phase `srmcmt3ph2spp` has been developed. The algorithm generates the output control word according to the desired action and the desired direction of the rotation. For example, when the phase A needs to be turned off, the algorithm sets the corresponding $OUTCTLx$ bits to enable the output control of the required PWMs and clears $OUTx$ bits to turn-off the PWMs. The other bits of the output control register are not affected.

5.3.3 Velocity Calculation

The process calculates the actual speed of the motor. It reads the time between the following falling edges of the Hall sensors output and calculates the actual motor speed `Omega_actual`. A software filter of the speed measurement is incorporated in the process for better noise immunity. The actual motor speed is calculated as an average value of the last four measurements.

5.3.4 Speed Controller

The process calculates the output duty cycle of the PWM according to the speed error. The speed error is the difference between the actual speed `Omega_actual` and the speed command `Omega_command`. The PI controller is implemented. The constants of the speed controller are tuned experimentally according to the actual load and the rating of the power stage.

5.3.5 PWM Generation

This process sets the on-chip PWM module for generation of the control pulses for the three-phase SR motor power stage. The generation of the pulses is based on the software control register, generated by the Commutation Calculation process, on the required duty cycle generated by the Process Speed Controller. The calculated software control word is loaded into the proper PWM register and the PWM duty cycle is updated according to the required duty cycle. The PWM Generation process is accessed regularly in a rate given by the PWM frequency. It is frequent enough to ensure the precise generation of commutation pulses.

5.4 Software Implementation

The general software diagram incorporates the Main routine entered from Reset and the interrupt states (see [Figure 5-2](#)).

The Main Routine provides board identification, initialization of the DSP, initialization of the application and then it enters an infinite background loop. The background loop contains a scheduler routine.

The scheduler routine provides the timing sequence for two tasks called in Timeout 1 and Timeout 2. The Timeout 1 and Timeout 2 flags are set by software timer interrupts. The scheduler utilizes these flags and calls the required routines:

- The routine in Timeout 1 handles the user interface, calculates the required speed, the start-up routines and the speed ramp (acceleration/deceleration)
- The routine in Timeout 2 executes the speed controller

The Timeout 1 and Timeout 2 tasks are performed in the run state, instead of in the interrupt routines, in order to avoid software bottlenecks. Since the usual time periods are in the range of msec, such a solution is fully sufficient. Note that these periods define the critical time period for the task scheduler.

The Timeout 1 and Timeout 2 tasks are performed in the run state, instead of in the interrupt routines, in order to avoid software bottlenecks. Since the usual time periods are in the range of msec, such a solution is fully sufficient. Note that these periods define the critical time period for the task scheduler.

The following interrupt service routines are utilized:

- Input Capture ISR - services signals generated by Hall sensors
- Fault ISR - services faults invoked by external hardware faults
- PWM Reload ISR - services an update of the PWM registers
- Timer ISR - services the generation of a time base for s/w timers
- Push Button Up ISR and Push Button Down ISR - services Up and Down Push Buttons
- ADC ISR - services the results of an Analog-to-Digital conversion
- SCI ISR - services the communication with the PC master software

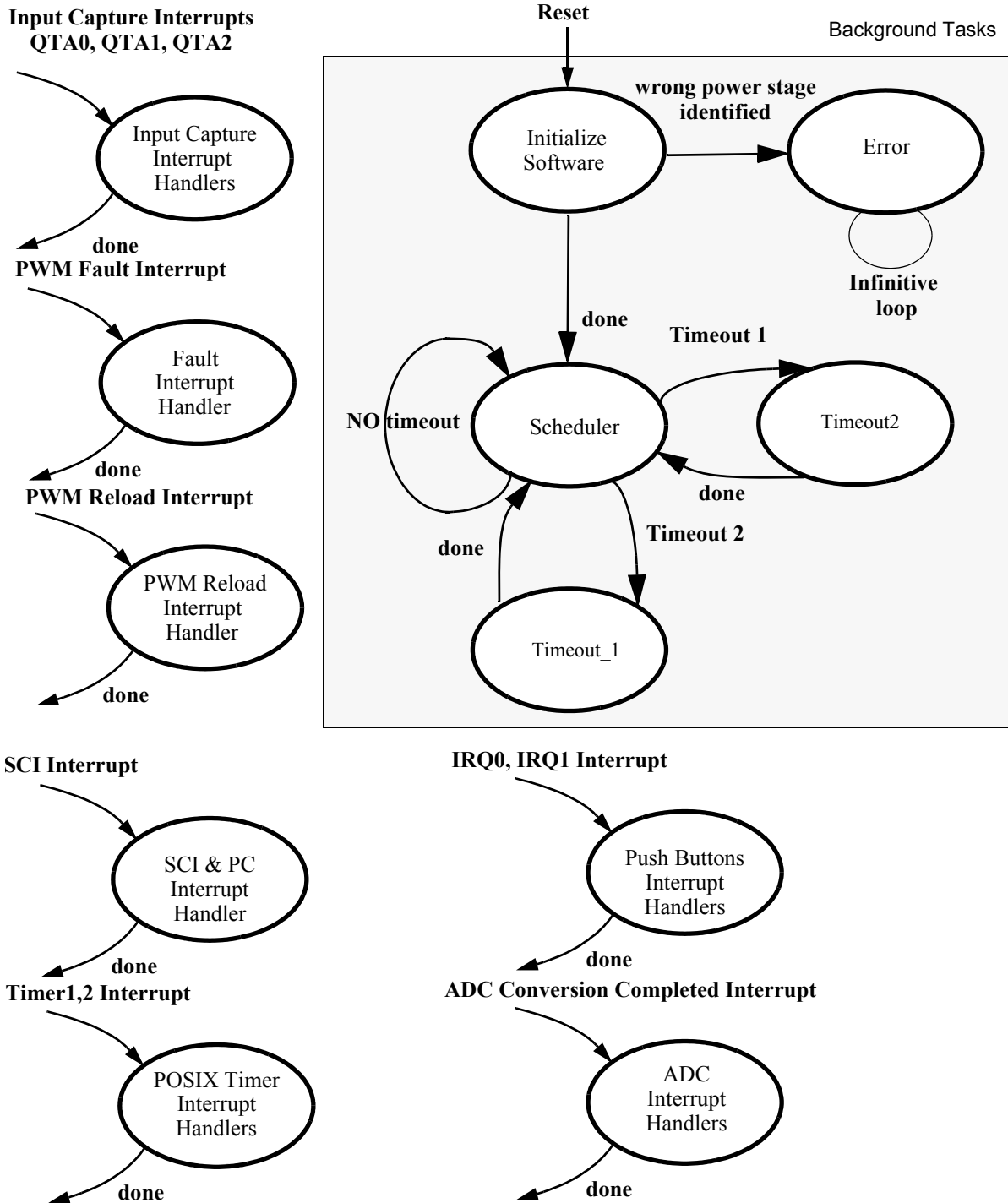

Figure 5-2. State Diagram - General Overview

5.4.1 Initialization

The Main Routine provides initialization of the DSP:

- disables Interrupts
- initializes DSP PLL
- disables COP and LVI
- initializes Timers for scheduler time reference
 - Timer 1 for time reference Timeout 1
 - Timer 2 for time reference Timeout 2
- initializes LED
- identifies hardware
 - In the case of wrong hardware, program stays in an infinite loop displaying the fault
 - In the case of correct hardware, the program sets the hardware status word accordingly
- initializes PWM module:
 - edge aligned independent PWM mode, positive polarity
 - PWM modulus - defines the PWM frequency
 - PWM interrupt reload each PWM pulse
 - FAULT2 (DC-Bus over-current fault) in manual mode, interrupt enabled
 - FAULT1 (DC-Bus over-voltage fault) in manual mode, interrupt enabled
 - associate interrupt with PWM reload event
 - associate interrupt with PWM fault event
- initializes Quadrature Decoder
 - sets on-chip digital filter of the Quadrature Decoder inputs
 - connects QuadDecoder signals to the QuadTimerA
- initializes QuadratureTimerA - channels A0, A1, A2
 - Input Capture on falling edge

- set positive polarity
- associate interrupt to the IC event
- sets-up I/O ports (brake, switch, push buttons)
 - brake, LED, switch on GPIO
 - push buttons on interrupts IRQ0, IRQ1
- initializes Analog-to-Digital Converter
 - ADC set for sequential sampling, single conversion
 - associate interrupt with ADC conversion completed event
 - channel 0 = DC-Bus voltage
 - channel 5 = temperature
- initializes control algorithm (speed controller, control algorithm parameters)
- enables interrupts
- starts ADC conversion
- identifies the voltage level according to the identified power stage

The board identification routine identifies the connected power stage board by decoding the identification message sent from the power stage. In the case the wrong power stage is identified, the program enters an infinite loop and displays the fault status on the LED. The infinite loop can be left only by RESET.

5.4.2 Interrupts

The interrupt handlers have the following functions:

Input Capture Interrupt Handlers read the time between the two subsequent falling edges of the Hall sensor, generate a commutation pattern and calculate the actual speed of the motor. Each of three position Hall sensors utilizes a separate Input Capture Interrupt. The description of the commutation pattern calculation is in [Section 2.3.3.2 “Commutation”](#) and [Section 5.3.2 “Commutation Calculation”](#). Speed measurement is described in [Section 5.3.3 “Velocity Calculation”](#).

- *Fault Interrupt Handlers* take care of the fault interrupts. The PWM Fault ISR is the highest priority interrupt implemented in the software. In the case of DC-Bus over-current or DC-Bus over-voltage fault detection, the external hardware circuit generates the corresponding fault signal that is detected on the Fault input pin of the DSP. The signals automatically disable the motor control PWM outputs in order to protect the power stage and generate a Fault interrupt, where the fault condition is handled. The routine records the corresponding fault source to the fault status register.
- *PWM Reload Interrupt Handler* provides phase commutation and generates the required voltage strokes for the SR motor. It loads the calculated commutation pattern to the PWM software control registers and the calculated duty cycle to all six PWM value registers.
- *Timer Interrupt Handlers* generate the two time-out references for the scheduler.
- *Push Button Interrupt Handler* takes care of the push button service. The *UpButton Interrupt Handler* increments the desired speed with the increment, the *DownButton Interrupt Handler* decrements the desired speed with the decrement
- *ADC Interrupt Handler* takes care of the ADC conversion process - starts conversion, reads converted value of voltage and temperature. It also provides software protection against over-temperature and DC-Bus under-voltage using filtered values of the DC-Bus voltage and the temperature of the power module. In the case of power module over-temperature and DC-Bus under-voltage, the handlers disable the motor and set the records of the corresponding fault source to the fault status register.
- *PC and SCI Interrupt Handlers* provide SCI communication and service routines of the PC master software. These routines are fully independent of the motor control tasks.

5.4.3 Scheduler

The scheduler routine provides the timing sequence for two timed outputs - Timeout 1 and Timeout 2.

5.4.3.1 State - Timeout 1

This state is accessed from the main scheduler in the Timeout 1 period (10msec). The following sequence is performed:

- Start/Stop switch status is scanned. The state of the switch is filtered through two sequential samples in order to increase noise protection. An algorithm also protects the drive against "start after reset" when the start/stop switch is left in the start position.
- According to the operational mode, the desired speed is calculated:
 - in manual mode according to the push buttons
 - in PC master operational mode according to the command from the PC
- The drive is enabled / disabled according to the control commands and fault status. If the drive is stopped, all required drive variables are initialized.
- If required, a start-up routine is performed and the start-up switching pattern is generated. For a detailed description refer to [Section 2.3.3.1 "Startup"](#).
- The command speed is calculated using the acceleration / deceleration ramp according to the desired speed.
- Subsequent ADC conversion is started ensuring that the ADC is started periodically.
- The LED is controlled according to the state of the drive. It can indicate the stop state, the run state, the fault states or the wrong power stage connected.

5.4.3.2 State - Timeout 2

This state is accessed from the main scheduler in the Timeout 2 period (15msec). In this state, the speed controller is performed and the corrected PWM duty cycle is calculated. The speed controller constants are determined experimentally and set during the initialization of the chip.

5.5 Implementation Notes

5.5.1 Scaling of Quantities

The SR motor control application uses a fractional representation for all real quantities except time. The N bit signed fractional format is represented using 1.[N-1] format (1 sign bit, N-1 fractional bits). Signed fractional numbers (SF) lie in the following range:

$$-1.0 \leq SF \leq +1.0 \cdot 2^{-[N-1]} \tag{5-1}$$

For words and long-word signed fractions, the most negative number that can be represented is -1.0, whose internal representation is \$8000 and \$80000000, respectively. The most positive word is \$7FFF or $1.0 - 2^{-15}$, and the most positive long-word is \$7FFFFFFF or $1.0 - 2^{-31}$.

The following equation shows the relationship between the real and the fractional representations:

$$\text{Fractional Value} = \frac{\text{Real Value}}{\text{Real Quantity Range}} \tag{5-2}$$

where:

Fractional Value is a fractional representation of the real value [Frac16]

Real Value is the real value of the quantity [V, A, rpm, etc.]

Real quantity range is the maximal range of the quantity, defined in the application [V, A, rmp, etc.]

5.5.2 Voltages Scaling

All the application voltages, (DC-Bus voltage, DC-Bus Under-voltage limit, start-up voltage) are scaled relative to the maximal measurable voltage. In the case of the DC-Bus voltage, the scaling equation is the following:

$$u_dc_bus = \frac{V_{DC_BUS}}{V_{MAX}} \quad (5-3)$$

Where:

u_dc_bus is the DC-Bus voltage variable [Frac16],

V_{DC_BUS} is the measured DC-Bus voltage [V],

V_{MAX} is the maximal measurable DC-Bus voltage, given by the design of the power stage [V].

In the application, $V_{MAX} = 407V$ for the high-voltage platform and $V_{MAX} = 15.9V$ for the low-voltage platform.

5.5.3 Speed Scaling

All the application speed variables (desired speed, actual motor speed, desired start-up speed, speed command, speed limits, push button speed increments) are scaled relative to the maximal measurable speed of the drive. For the desired start-up speed, the scaling equation is the following:

$$\omega_desired_startup = \frac{\omega_{start_up}}{\omega_{MAX}} \quad (5-4)$$

Where:

$\omega_desired_startup$ is the desired start-up speed variable [Frac16],

ω_{start_up} is the desired start-up speed in [rpm],

ω_{MAX} is the maximal measurable speed of the drive [rpm].

In the application, $\omega_{MAX} = 3000$ rpm.

5.5.4 Duty-Cycle Scaling

All the application duty-cycle variables (output duty-cycle, high- and low-duty-cycle limits for the speed controller) are scaled relative to the maximal applicable duty cycle of the drive. For output duty cycle the equation is following:

$$output_duty_cycle = \frac{duty_cycle_{output}}{duty_cycle_{MAX}} \quad (5-5)$$

Where:

output_duty_cycle is the output duty-cycle variable [Frac16],

duty_cucle_{output} is the desired output duty-cycle [%],

duty_cycle_{MAX} is the maximal applicable duty-cycle [%].

In the application, *duty_cycle_{MAX}* = 100 %

5.5.5 Velocity calculation

The actual speed of the motor is calculated from the time *TimeCaptured*, captured by the on-chip Quadrature Timer between the two following edges of the position Hall sensors. The actual speed *OmegaActual* is calculated according to the following equation:

$$OmegaActual = \frac{SpeedCalcConst}{TimeCaptured} \quad (5-6)$$

where:

OmegaActual is the actual speed [rpm]

TimeCaptured is the time, in terms of number of timer pulses, captured between two edges of the position sensor [-],

SpeedCalcConst is a constant defining the relation between the actual speed and number of captured pulses between the two edges of the position sensor.

The constant *SpeedCalcConst* is calculated as

$$SpeedCalcConst = 2^{15} \times \frac{SpeedMin}{SpeedMax} \quad (5-7)$$

where:

SpeedMin is the minimal measurable speed [rpm],

SpeedMax is the maximal measured speed [rpm].

Minimal measured speed, *SpeedMin*, is given by the configuration of the sensors and parameters of the DSP on-chip timer, used for speed measurement. It is calculated as:

$$SpeedMin = \frac{\frac{1}{NoPulsesPerRev} \times 60}{\frac{2^{15}}{BusClockFreq} \times Presc} \quad (5-8)$$

where:

NoPulsesPerRev is the number of sensed pulses of the position sensor per one revolution [-]

Presc is the prescaler of the Quadrature Timer used for the speed measurements

BusClockFreq is the DSP Bus Clock Frequency [Hz]

Maximal measured speed, *SpeedMax*, is selected

$$SpeedMax = k \times SpeedMin \quad (5-9)$$

where:

k is an integer constant greater than 1.

Then the speed calculation constant is determined as:

$$SpeedCalcConst = BusClockFreq \times \frac{60}{NoPulsesPerRev \times Presc \times SpeedMax} \quad (5-10)$$

Where:

$NoPulsesPerRev = 12$ Hall sensors pulses per 1 revolution of the motor,

$Presc = 128$,

$BusClockFreq = 36 \cdot 10^6$ Hz,

$SpeedMax = 3000$ rpm.

Then, $SpeedCalcConst = 468$ [rev⁻¹]



Section 6. Application Setup

6.1 Contents

6.2	Application Description	75
6.3	Application Set-Up	79
6.3.1	DSP56F805EVM Set-Up	82
6.4	Projects Files	84
6.5	Application Build & Execute	85

6.2 Application Description

The 3-Phase SR Motor Control Application performs principal control of the 3-phase SR motor with Hall Sensors on the DSP56F805 processor. The control technique sets the motor speed ([rpm]) to the required value using the speed closed loop with Hall Position Sensors to derive the proper commutation action/moment. Protection against drive faults Overcurrent, Overvoltage, Undervoltage, and overheating is provided.

The application can run on:

- External RAM or Flash
- 3-Phase SR High-Voltage Power Stage powered by 115 or 230V AC
- 3-Phase SR Low-Voltage Power Stage powered by 12V DC
- Manual or PC master software Operating Mode

This 3-Phase SR Motor Control Application with Hall Sensors can operate in two modes:

1. Manual Operating Mode
The drive is controlled by the RUN/STOP switch (S6). The motor

speed is set by the UP (S2-IRQB) and DOWN (S1-IRQA) push buttons; see **Figure 6-1**. If the application runs and motor spinning is disabled (i.e., the system is ready) the USER LED (LED3, shown in **Figure 6-2**) will blink. When motor spinning is enabled, the USER LED is *On*. Refer to **Table 6-1** for application states.

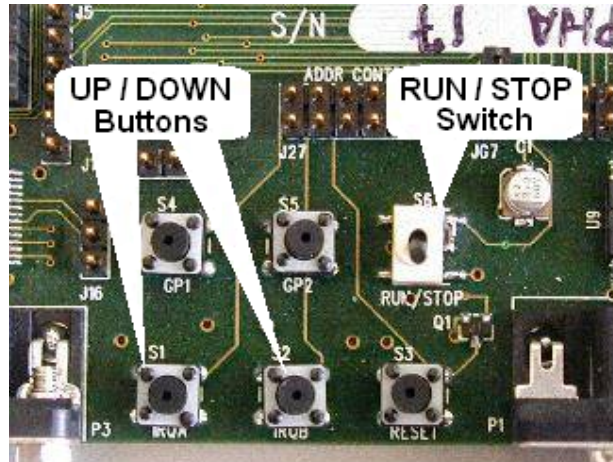

Figure 6-1. RUN/STOP Switch and UP/DOWN Buttons

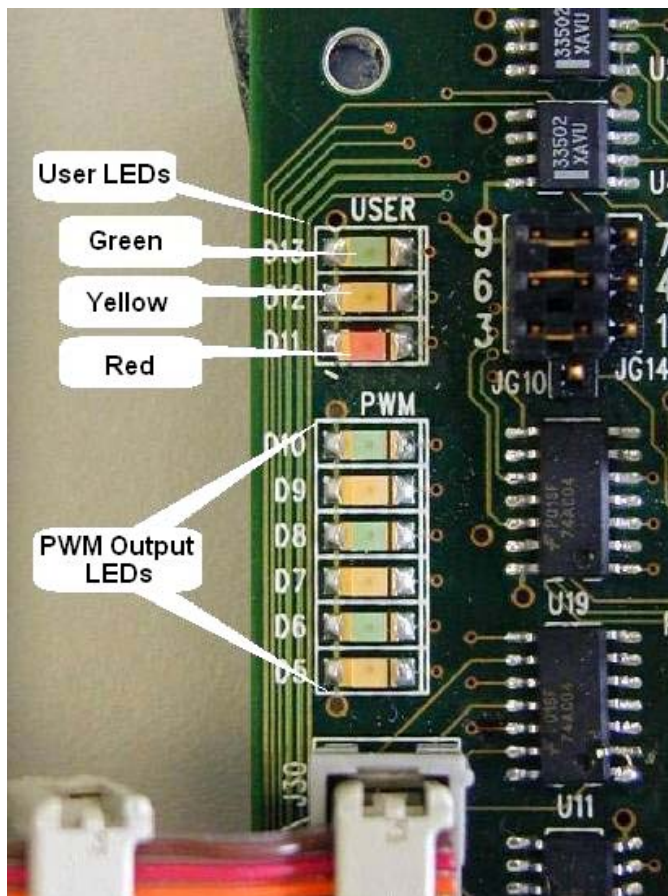

Figure 6-2. USER and PWM LEDs at DSP56F805EVM

Table 6-1. Motor Application States

Application State	Motor State	Green LED State
Stopped	Stopped	Blinking at a frequency of 2Hz
Running	Spinning	On
Fault	Stopped	Blinking at a frequency of 8Hz

2. PC master software (Remote) Operating Mode
The drive is controlled remotely from a PC through the SCI communication channel of the DSP device via an RS-232 physical interface. The drive is enabled by the RUN/STOP switch, which

can be used to safely stop the application at any time. PC master software enables to set the required speed of the motor.

The following control actions are supported:

- Set PC master software Mode of the motor control system
- Set Manual Mode of the motor control system
- Start the motor
- Stop the motor
- Set the Required Speed of the motor

PC master software displays the following information:

- Required Speed of the motor
- Actual Speed of the motor
- Motor status - Running/Stand-by
- Fault Status

Start the PC master software window's application, *3srm_hall_sa.pmp*. **Figure 6-3** illustrates the PC master software control window after this project has been launched.

NOTE: *If the PC master software project (.pmp file) is unable to control the application, it is possible that the wrong load map (.elf file) has been selected. PC master software uses the load map to determine addresses for global variables being monitored. Once the PC master software project has been launched, this option may be selected in the PC master software window under Project/Select Other Map FileReload.*

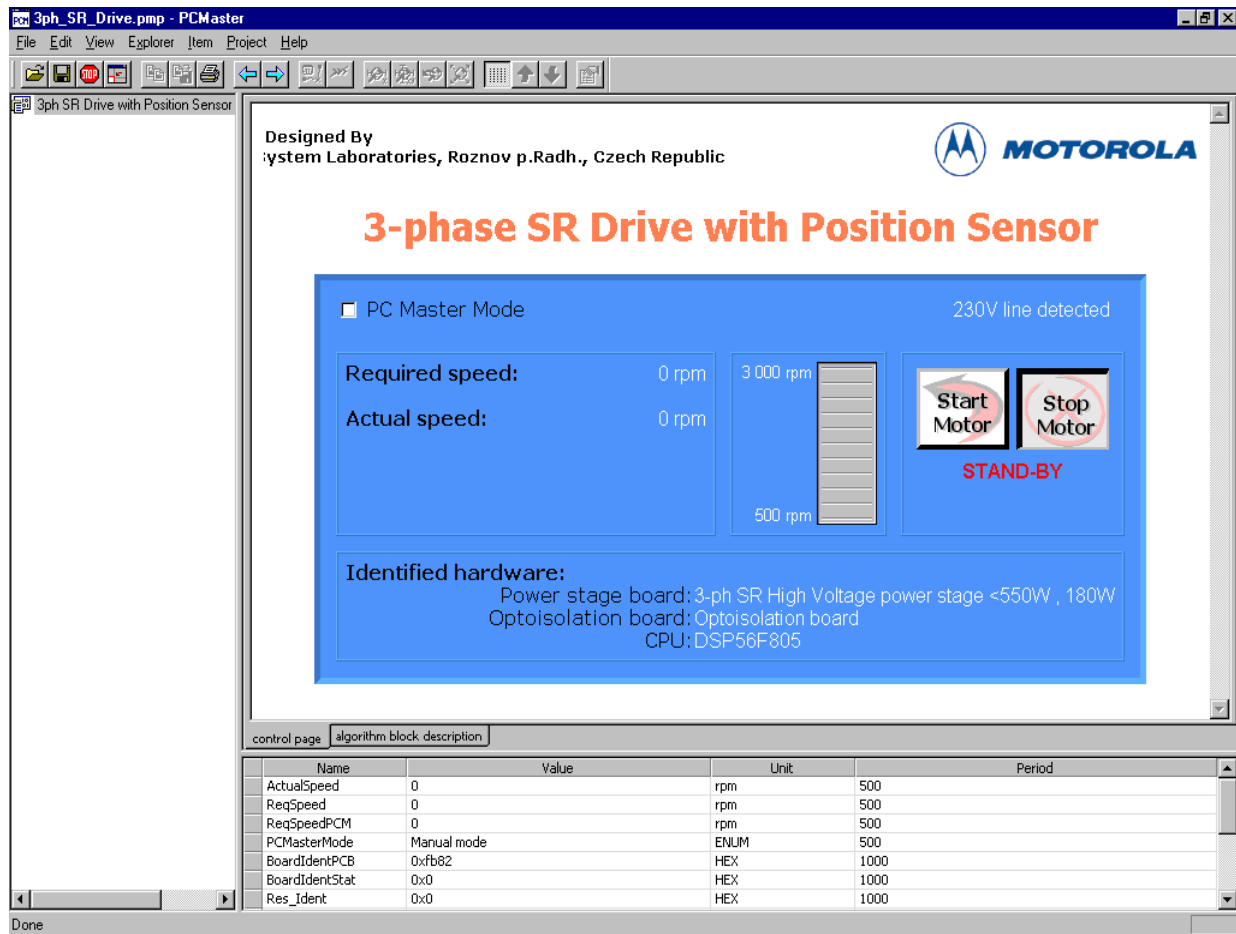

Figure 6-3. PC Master Software Control Window

6.3 Application Set-Up

Figure 6-4 and Figure 6-5 illustrate the hardware set-ups for the 3-Phase SR Motor Control Application with Hall Sensors.

Application Setup

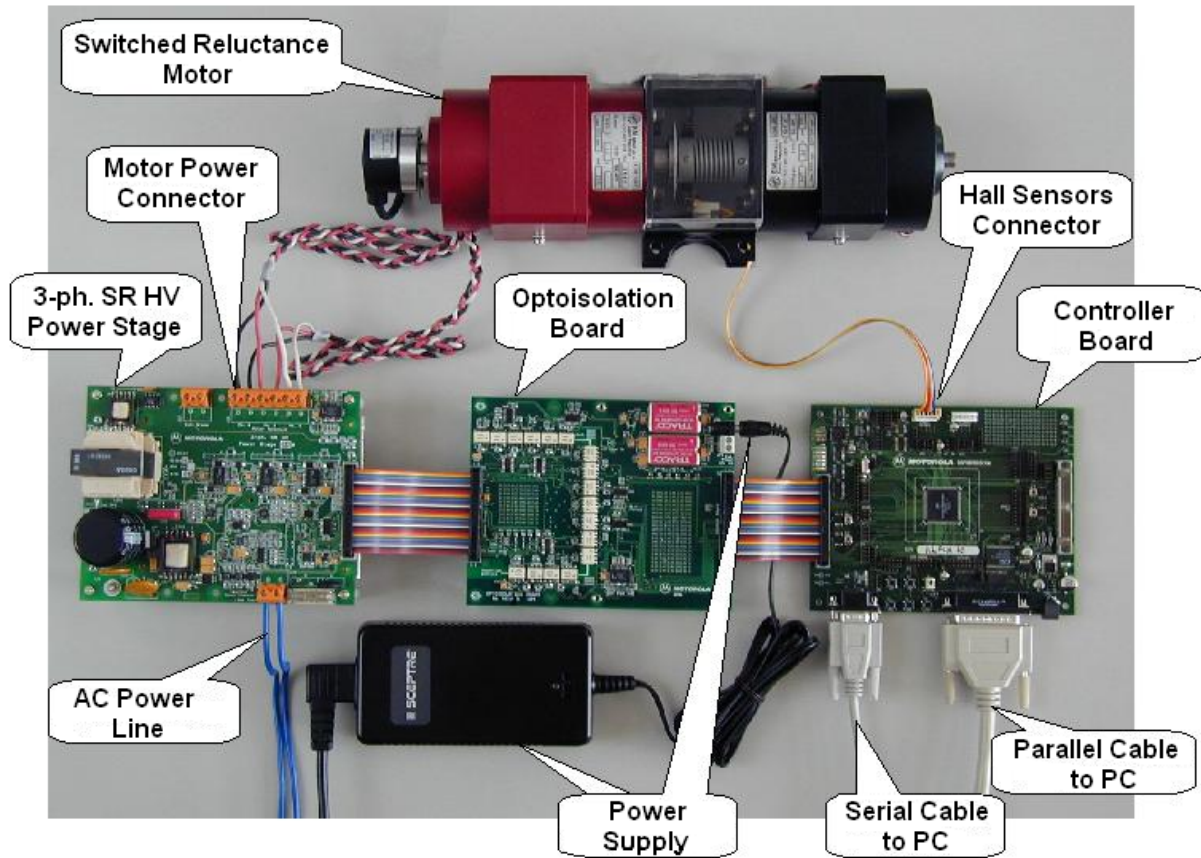

Figure 6-4. Setup of the 3-phase HV SR Motor Control Application

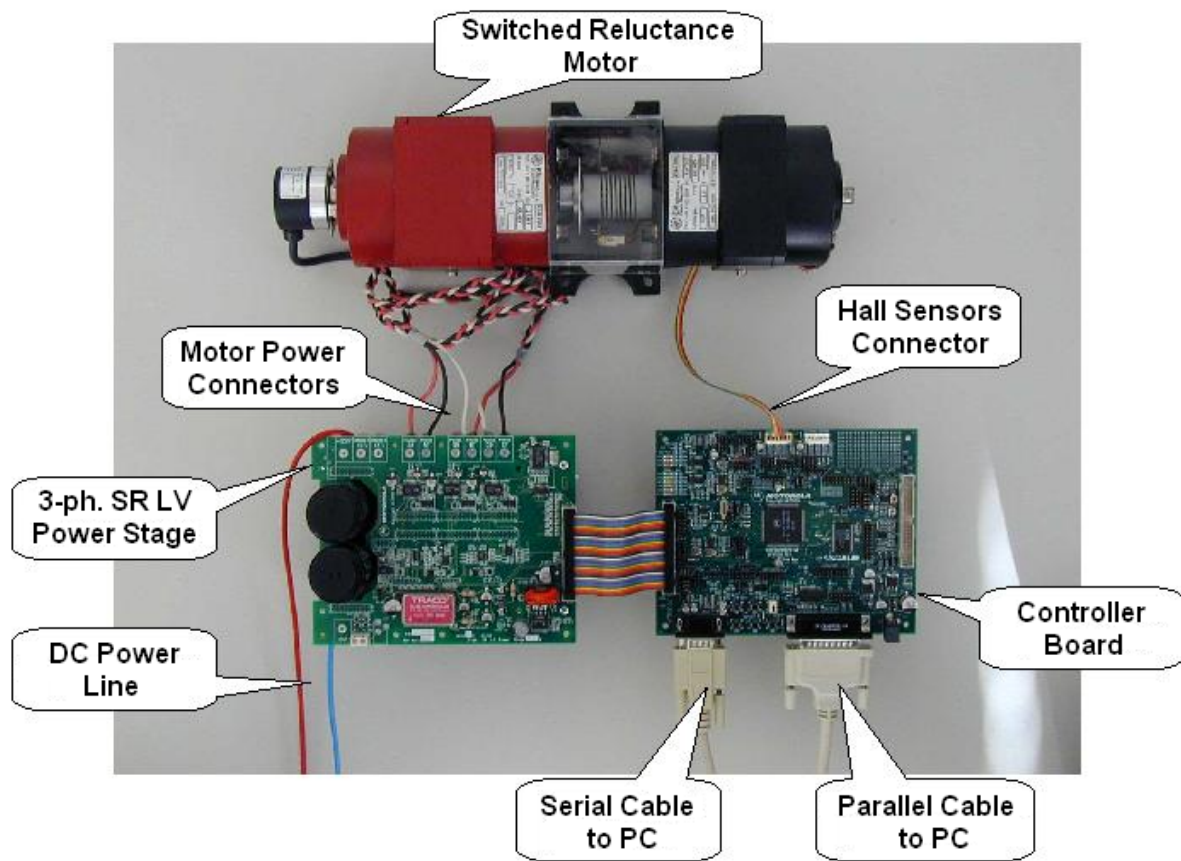

Figure 6-5. Set-up of the 3-phase LV SR Motor Control Application

The correct order of phases (phase A, phase B, phase C) for the SR motor is:

- phase A = white wire
- phase B = red wire
- phase C = black wire

When facing a motor shaft, the motor shaft should rotate clockwise (i.e., positive direction, positive speed).

For detailed information, see the **DSP56F805 Evaluation Module Hardware Reference Manual**. The serial cable is needed for the PC master software debugging tool only.

The system consists of the following components:

- Switched reluctance motor Type 40V or 40N, EM Brno s.r.o., Czech Republic
- Load Type SG 40N, EM Brno s.r.o., Czech Republic
- Hall Sensors 12 pulses per revolution
- 3-ph. SR HV or LV Power Stage 180 W:
- Optoisolation Board
- DSP56F805 Evaluation Module, supplied as DSP56F805EVM
- The serial cable - needed for the PC master software debugging tool only.
- The parallel cable - needed for the Metrowerks Code Warrior debugging and s/w loading.

For detailed information, refer to the dedicated application note (see References).

6.3.1 DSP56F805EVM Set-Up

To execute the 3-Phase SR Motor Control with Hall Sensors, the DSP56F805EVM board requires the strap settings shown in [Figure 6-6](#) and [Table 6-2](#).

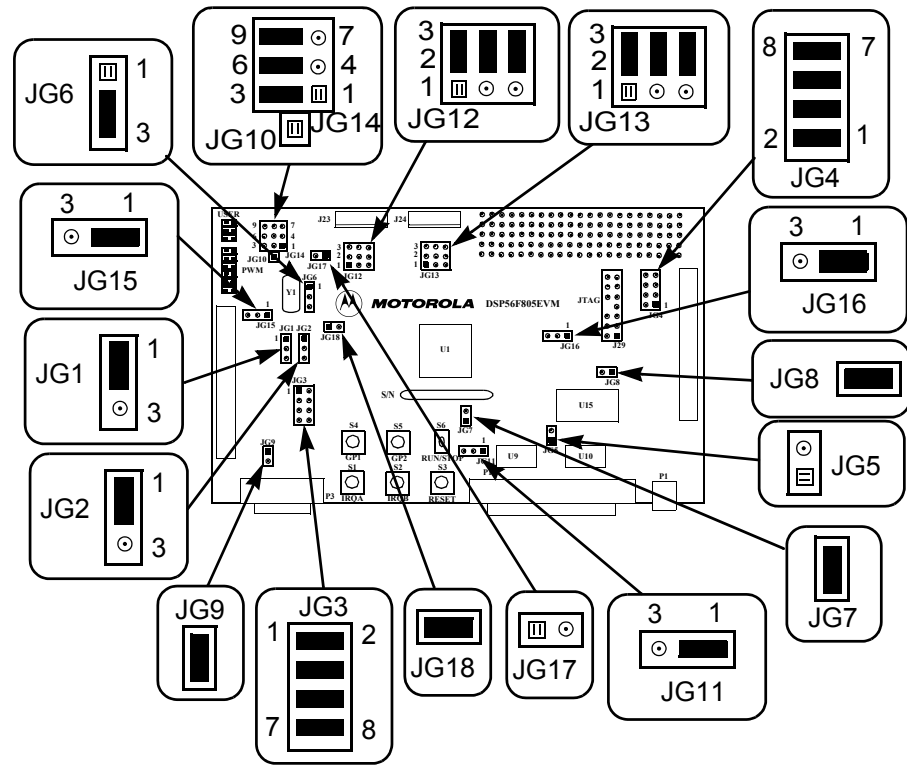

Figure 6-6. DSP56F805EVM Jumper Reference

Table 6-2. DSP56F805EVM Jumper Settings

Jumper Group	Comment	Connections
JG1	PD0 input selected as a high	1-2
JG2	PD1 input selected as a high	1-2
JG3	Primary UNI-3 serial selected	1-2, 3-4, 5-6, 7-8
JG4	Secondary UNI-3 serial selected	1-2, 3-4, 5-6, 7-8
JG5	Enable on-board parallel JTAG Command Converter Interface	NC
JG6	Use on-board crystal for DSP oscillator input	2-3
JG7	Select DSP's Mode 0 operation upon exit from reset	1-2
JG8	Enable on-board SRAM	1-2
JG9	Enable RS-232 output	1-2

Table 6-2. DSP56F805EVM Jumper Settings

Jumper Group	Comment	Connections
JG10	Secondary UNI-3 Analog temperature input unused	NC
JG11	Use Host power for Host target interface	1-2
JG12	Primary Encoder input selected for Hall Sensor signals	2-3, 5-6, 8-9
JG13	Secondary Encoder input selected	2-3, 5-6, 8-9
JG14	Primary UNI-3 3-Phase Current Sense selected as Analog Inputs	2-3, 5-6, 8-9
JG15	Secondary UNI-3 Phase A Overcurrent selected for FAULTA1	1-2
JG16	Secondary UNI-3 Phase B Overcurrent selected for FAULTB1	1-2
JG17	CAN termination unselected	NC
JG18	Use on-board crystal for DSP oscillator input	1-2

NOTE: When running the EVM target system in a stand-alone mode from Flash, the JG5 jumper must be set in the 1-2 configuration to disable the command converter parallel port interface.

6.4 Projects Files

The 3-Phase SR Motor Control application with Hall Sensors is composed of the following files:

- ...**3srm_hall_sa**\3srm_hall.c, main program
- ...**3srm_hall_sa**\3srm_hall_sa.mcp, application project file
- ...**3srm_hall_sa**\ApplicationConfig\appconfig.h, application configuration file
- ...**3srm_hall_sa**\SystemConfig\ExtRam\linker_ram.cmd, linker command file for external RAM
- ...**3srm_hall_sa**\SystemConfig\Flash\linker_flash.cmd, linker command file for Flash
- ...**3srm_hall_sa**\SystemConfig\Flash\flash.cfg, configuration file for Flash

- ...**3srm_hall_sa**\PCMaster\bldc_hall_sensors.pmp, PC master software file

These files are located in the application folder.

Motor Control algorithms used in the application:

- ...**controllers.c, .h**: source and header files for PI controller
- ...**ramp.c, .h**: source and header files for ramp generation
- ...**SrmCmt3Ph2spp.c, .h**: source and header files for SR Motor commutation algorithm

Other functions used in the application:

- ...**boardId.c, .h**: source and header files for the board identification function

This application runs stand-alone, i.e. all the needed files are concentrated in one project folder. Quick_Start libraries are:

- ...**3srm_hall_sa**\src\include, folder for general C-header files
- ...**3srm_hall_sa**\src\dsp56805, folder for the device specific source files, e.g. drivers
- ...**3srm_hall_sa**\src\pc_master_support, folder for PC master software source files
- ...**3srm_hall_sa**\src\algorithms\, folder for algorithms

6.5 Application Build & Execute

When building the 3-Phase SR Motor Control Application with Hall Sensors, the user can create an application that runs from internal *Flash* or *External RAM*. To select the type of application to build, open the *3srm_hall_sa.mcp* project and select the target build type, as shown in [Figure 6-7](#). A definition of the projects associated with these target build types may be viewed under the *Targets* tab of the project window.

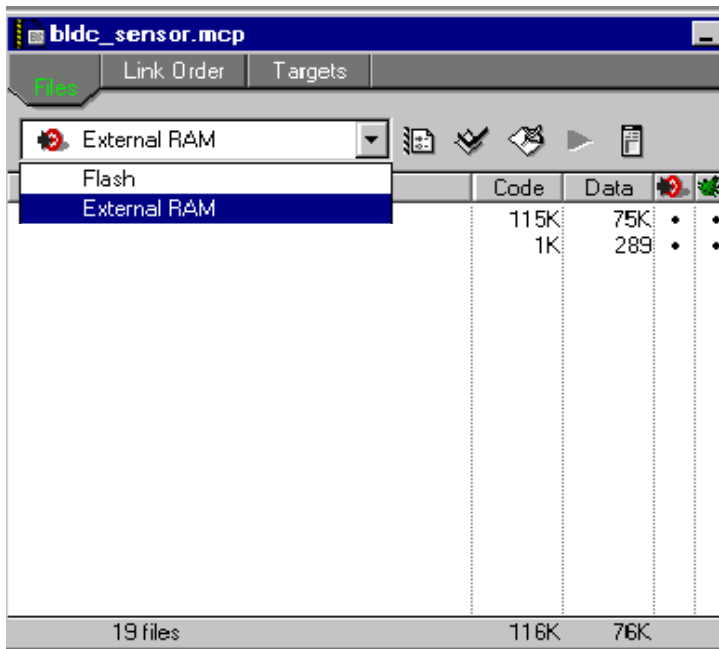

Figure 6-7. Target Build Selection

The project may now be built by executing the *Make* command, as shown in Figure 6-8. This will build and link the 3-Phase SR Motor Control Application with Hall Sensors and all needed Metrowerks and Quick_Start libraries.

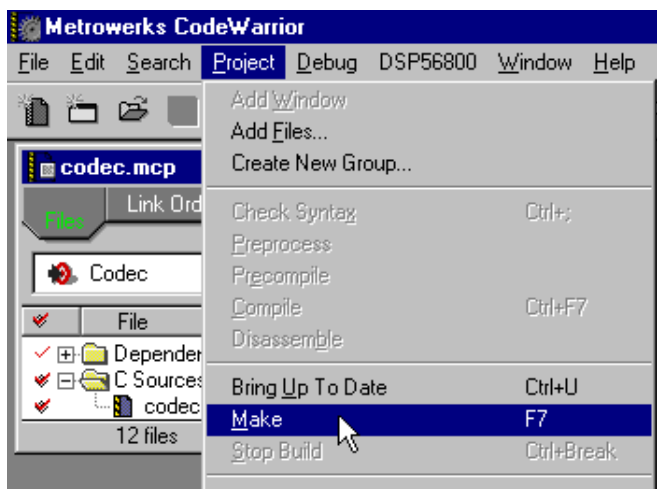

Figure 6-8. Execute *Make* Command

To execute the 3-Phase SR Motor Control application, select *Project\Debug* in the CodeWarrior IDE, followed by the *Run* command. For more help with these commands, refer to the CodeWarrior tutorial documentation in the following file located in the CodeWarrior installation folder:

<...>\CodeWarrior Documentation\PDF\Targeting_DSP56800.pdf

If the Flash target is selected, CodeWarrior will automatically program the internal Flash of the DSP with the executable generated during *Build*. If the External RAM target is selected, the executable will be loaded to off-chip RAM.

Once Flash has been programmed with the executable, the EVM target system may be run in a stand-alone mode from Flash. To do this, set the JG5 jumper in the 1-2 configuration to disable the parallel port, and press the RESET button.

Once the application is running, move the RUN/STOP switch to the RUN position and set the required speed using the UP/DOWN push buttons. Pressing the UP/DOWN buttons should incrementally increase the motor speed until it reaches maximum speed. If successful, the BLDC motor will be spinning.

NOTE: *If the RUN/STOP switch is set to the RUN position when the application starts, toggle the RUN/STOP switch between the STOP and RUN positions to enable motor spinning. This is a protection feature that prevents the motor from starting when the application is executed from CodeWarrior.*

You should also see a lighted green LED, which indicates that the application is running. If the application is stopped, the green LED will blink at a 2Hz frequency. If an Undervoltage fault occurs, the green LED will blink at a frequency of 8Hz.



Appendix A. References

1. **Switched Reluctance Motors and Their Control**, T.J.E. Miller, Magna Physics Publishing and Clarendon Press, ISBN 0-19-859387-2, 1993
2. **CodeWarrior for Motorola DSP56800 Embedded Systems**, CWDSP56800, Metrowerks 2001
3. **DSP56F800 16-bit Digital Signal Processor, Family Manual**, DSP56F800FM/D, Motorola 2001
4. **DSP56F80x 16-bit Digital Signal Processor, User's Manual**, DSP56F801-7UM/D, Motorola 2001
5. **DSP56F805 Evaluation Module Hardware User's Manual**, DSP56F805EVMUM/D, Motorola 2001
6. **Motorola Embedded Motion Optoisolation Board User's Manual**, MEMCOBUM/D, Motorola 2000
7. **Motorola Embedded Motion Control 3-Phase Switched Reluctance High-Voltage Power Stage User's Manual**, MEMC3PSRHVPSUM/D, Motorola 2000
8. **Motorola Embedded Motion Control 3-Phase Switched Reluctance Low-Voltage Power Stage User's Manual**, MEMC3PSRLVPSUM/D, Motorola 2000
9. **Embedded Software Development Kit for 56800/56800E**, MSW3SDK000AA, available on Motorola SPS web page, Motorola 2001
10. **User Manual** of PC master software, included in the SDK documentation, Motorola 2001
11. **Motorola SPS web page**: <http://e-www.motorola.com/>
12. **CodeWarrior for Motorola DSP56800 Embedded Systems**, CWDSP56800, Metrowerks 2001

References

13. **DSP56F805 Evaluation Module Hardware User's Manual**, DSP56F805EVMUM/D, Motorola 2001
14. **Motorola Embedded Motion Control 3-Phase Switched Reluctance Low-Voltage Power Stage User's Manual**, MEMC3PSRLVPSUM, Motorola 2000
15. **Motorola Embedded Motion Optoisolation Board User's Manual**, MEMCOBUM/D, Motorola 2000
16. **User Manual** for PC master software, Motorola 2001
17. **DSP56800_Quick_Start User's Manual**, MCSL 2002
18. **Motor Control Algorithms Description**, MCSL 2002

Appendix B. Glossary

AC — Alternating Current.

ADC — See “analogue-to-digital converter”.

brush — A component transferring electrical power from non-rotational terminals, mounted on the stator, to the rotor

BLDC — Brushless dc motor.

commutation — A process providing the creation of a rotation field by switching of power transistor (electronic replacement of brush and commutator)

commutator — A mechanical device alternating DC current in DC commutator motor and providing rotation of DC commutator motor

COP — Computer Operating Properly timer

DC — Direct Current.

DSP — Digital Signal Processor.

DSP56F80x — A Motorola family of 16-bit DSPs dedicated for motor control.

DT — see “Dead Time (DT)”

Dead Time (DT) — short time that must be inserted between the turning off of one transistor in the inverter half bridge and turning on of the complementary transistor due to the limited switching speed of the transistors.

duty cycle — A ratio of the amount of time the signal is on versus the time it is off. Duty cycle is usually represented by a percentage.

GPIO — General Purpose Input/Output.

Hall Sensors - A position sensor giving six defined events (each 60 electrical degrees) per electrical revolution (for 3-phase motor)

interrupt — A temporary break in the sequential execution of a program to respond to signals from peripheral devices by executing a subroutine.

input/output (I/O) — Input/output interfaces between a computer system and the external world. A CPU reads an input to sense the level of an external signal and writes to an output to change the level on an external signal.

HV — High Voltage (115 V AC or 230 V AC)

JTAG — Interface allowing On-Chip Emulation and Programming.

LED — Light Emitting Diode

logic 1 — A voltage level approximately equal to the input power voltage (V_{DD}).

logic 0 — A voltage level approximately equal to the ground voltage (V_{SS}).

LV — Low Voltage (12 V DC)

PI controller — Proportional-Integral controller.

phase-locked loop (PLL) — A clock generator circuit in which a voltage controlled oscillator produces an oscillation which is synchronized to a reference signal.

PM — Permanent Magnet

PMSM - Permanent Magnet Synchronous Motor.

PWM — Pulse Width Modulation.

Quadrature Decoder — A module providing decoding of position from a quadrature encoder mounted on a motor shaft.

Quad Timer — A module with four 16-bit timers.

reset — To force a device to a known condition.

RPM — Revolutions per minute.

SCI — See "serial communication interface module (SCI)."

serial communications interface module (SCI) — A module that supports asynchronous communication.

serial peripheral interface module (SPI) — A module that supports synchronous communication.

software — Instructions and data that control the operation of a microcontroller.

software interrupt (SWI) — An instruction that causes an interrupt and its associated vector fetch.

SPI — See "serial peripheral interface module (SPI)."

timer — A module used to relate events in a system to a point in time.





Freescale Semiconductor, Inc.

Freescale Semiconductor, Inc.

**For More Information On This Product,
Go to: www.freescale.com**

HOW TO REACH US:**USA/EUROPE/LOCATIONS NOT LISTED:**

Motorola Literature Distribution;
P.O. Box 5405, Denver, Colorado 80217
1-303-675-2140 or 1-800-441-2447

JAPAN:

Motorola Japan Ltd.; SPS, Technical Information Center,
3-20-1, Minami-Azabu Minato-ku, Tokyo 106-8573 Japan
81-3-3440-3569

ASIA/PACIFIC:

Motorola Semiconductors H.K. Ltd.;
Silicon Harbour Centre, 2 Dai King Street,
Tai Po Industrial Estate, Tai Po, N.T., Hong Kong
852-26668334

TECHNICAL INFORMATION CENTER:

1-800-521-6274

HOME PAGE:

<http://motorola.com/semiconductors>

Information in this document is provided solely to enable system and software implementers to use Motorola products. There are no express or implied copyright licenses granted hereunder to design or fabricate any integrated circuits or integrated circuits based on the information in this document.

Motorola reserves the right to make changes without further notice to any products herein. Motorola makes no warranty, representation or guarantee regarding the suitability of its products for any particular purpose, nor does Motorola assume any liability arising out of the application or use of any product or circuit, and specifically disclaims any and all liability, including without limitation consequential or incidental damages. "Typical" parameters which may be provided in Motorola data sheets and/or specifications can and do vary in different applications and actual performance may vary over time. All operating parameters, including "Typicals" must be validated for each customer application by customer's technical experts. Motorola does not convey any license under its patent rights nor the rights of others. Motorola products are not designed, intended, or authorized for use as components in systems intended for surgical implant into the body, or other applications intended to support or sustain life, or for any other application in which the failure of the Motorola product could create a situation where personal injury or death may occur. Should Buyer purchase or use Motorola products for any such unintended or unauthorized application, Buyer shall indemnify and hold Motorola and its officers, employees, subsidiaries, affiliates, and distributors harmless against all claims, costs, damages, and expenses, and reasonable attorney fees arising out of, directly or indirectly, any claim of personal injury or death associated with such unintended or unauthorized use, even if such claim alleges that Motorola was negligent regarding the design or manufacture of the part.



Motorola and the Stylized M Logo are registered in the U.S. Patent and Trademark Office. digital dna is a trademark of Motorola, Inc. All other product or service names are the property of their respective owners. Motorola, Inc. is an Equal Opportunity/Affirmative Action Employer.

© Motorola, Inc. 2003

DRM032/D

**For More Information On This Product,
Go to: www.freescale.com**