

Contents	
6	ETHERNET PHY1
7	ETHERNET PHY2-3
8	ETHERNET CONT
9	SATA & PCIE
10	USB
11	POR
12	PERIPHERALS
13	CPLD
14	CPU POWER
15	POWER SUPPLY (CPU)
16	POWER SUPPLY (MISC)

Revisions			
Rev	Description	Date	Approved
A	Original Release	9/10/09	T.Q
A1	DNP R315.Install R316	11/19/09	T.Q
	Remove R160		
	Pull up U29.1/4		
	DNP R32.Install R34		
	DNP R70.Install R74		
	DNP R51.Install R63		
	Change relay power to 5V Add protect diode		
	Change 25M crystal due to height limit Add 4.7k pull up on LGPL4 Change C72/C73 to 8pf		
B	Release for pilot	12/01/09	T.Q
B1	Fixed wrong symbol of part 480-75983	02/02/10	T.Q
	Changed power input from ATX to PD45		
	Added +3.3V DC-DC output		
	Reassigned RJ45 UART pin order		

P2020SECURE-4000/2000/1000

	SECURE-1000	SECURE-2000	SECURE-4000
CPU	QorIQ P2010E 800 MHz	QorIQ P2020E 800 MHz	QorIQ P2020E 1.2 GHz

		Networking & Multimedia Group 6501 William Cannon Drive West Austin, TX 78758-6598	
<small>This document contains information proprietary to Freescale Semiconductor and shall not be used for engineering design, procurement or manufacture in whole or in part without the express written permission of Freescale Semiconductor.</small>			
Designer: <Designer>		ICAP Classification: FQP: FUC: X PUB:	
Drawing Title: P2020SECURE-4000/2000/1000		Drawn by: <DrawnBy>	
Page Title: COVER PAGE		Approved: <Approver>	
Size C	Document Number SCH-26146 PDF: SPF-26146	Date: Tuesday, February 02, 2010	Rev B1
		Sheet 1 of 16	

All polarized capacitors are aluminum electrolytic

- Interrupted lines coded with the same letter or letter combinations are electrically connected.
- Device type number is for reference only. The number varies with the manufacturer.
- Special signal usage:
 _B Denotes - Active-Low Signal
 <> or [] Denotes - Vectored Signals
- Interpret diagram in accordance with American National Standards Institute specifications, current revision, with the exception of logic block symbology.

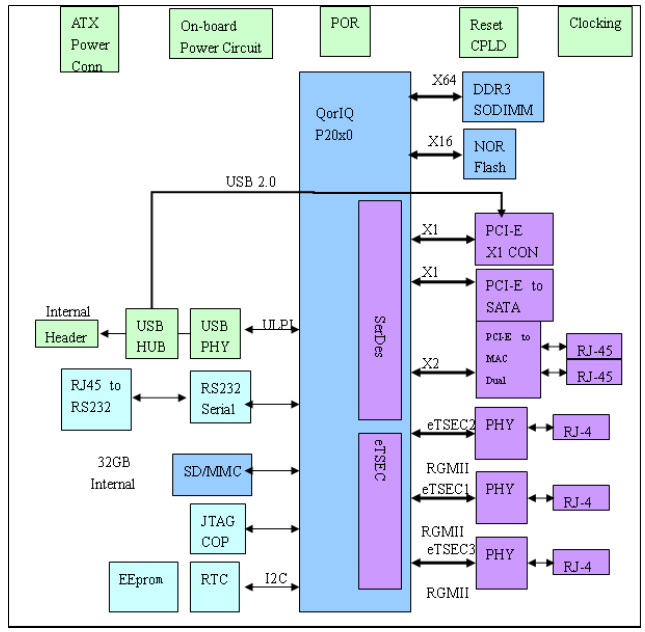

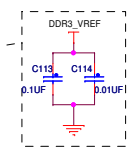
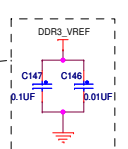
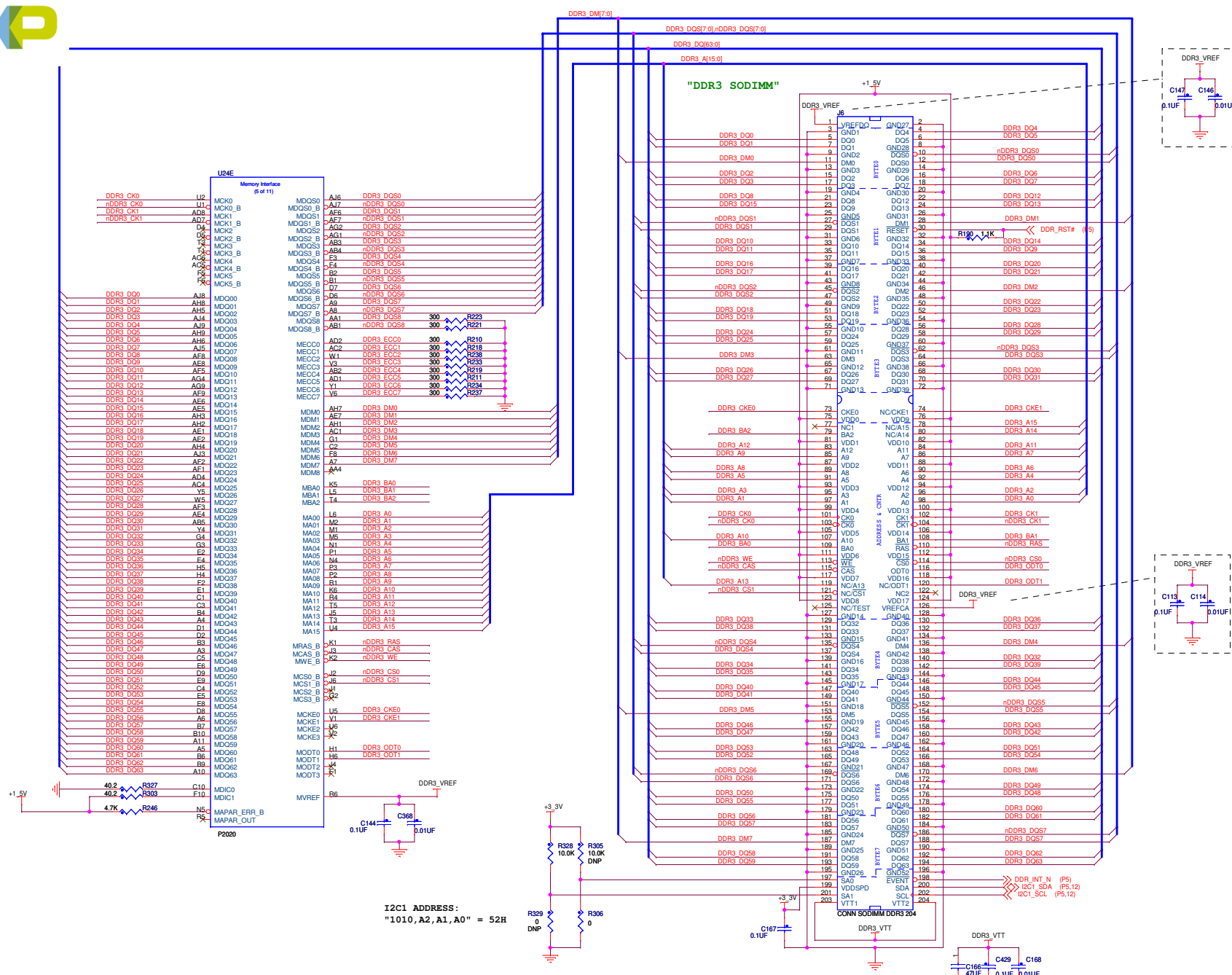

I2C1 ADDRESS:
"1010,A2,A1,A0" = 52H

freescale
semiconductor

ICAP Classification: FCP, FIUC: X, PUBI:
Drawing Title: **P2020SECURE-4000/2000/1000**

Page Title: **DDR**

Size	Document Number	SCH-26146 PDF: SPF-26146	Rev
C			B1

Date: Tuesday, February 02, 2010 | Sheet 3 of 16

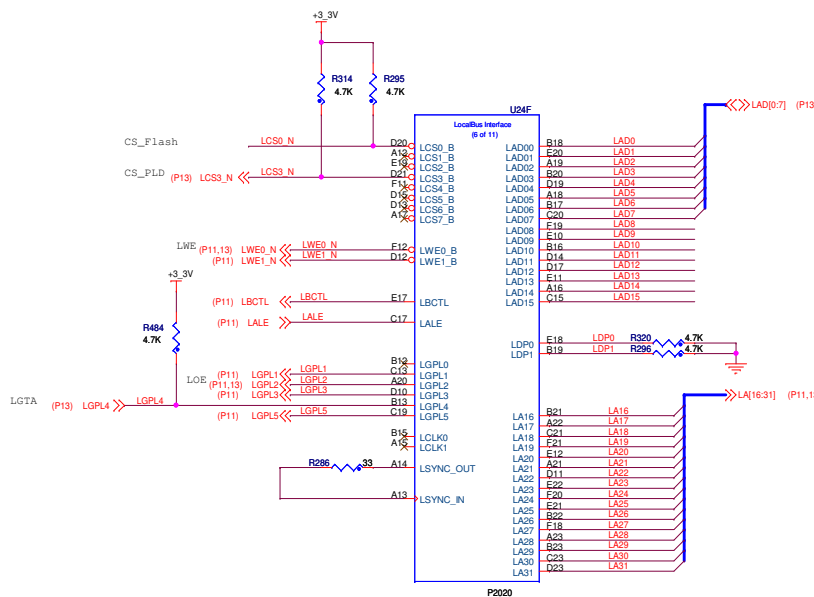

LOCAL BUS INTERFACE
ADDRESS - LATCH

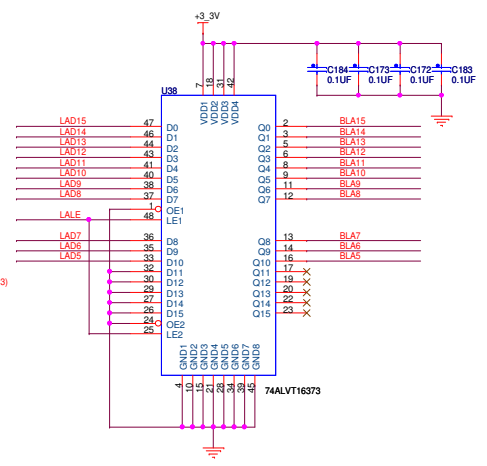

NOR FLASH

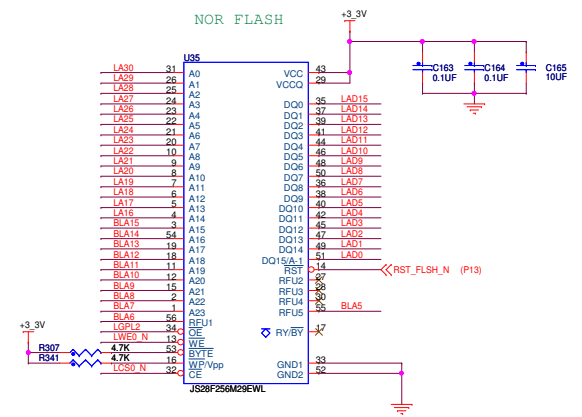

freescale
semiconductor

ICAP Classification: FCP: FIUC: X PUB: _____
Drawing Title: **P2020SECURE-4000/2000/1000**

Page Title: **FLASH**

Size	Document Number	Rev
C	SCH-26146 PDF: SPF-26146	B1

Date: Tuesday, February 02, 2010 Sheet 4 of 16

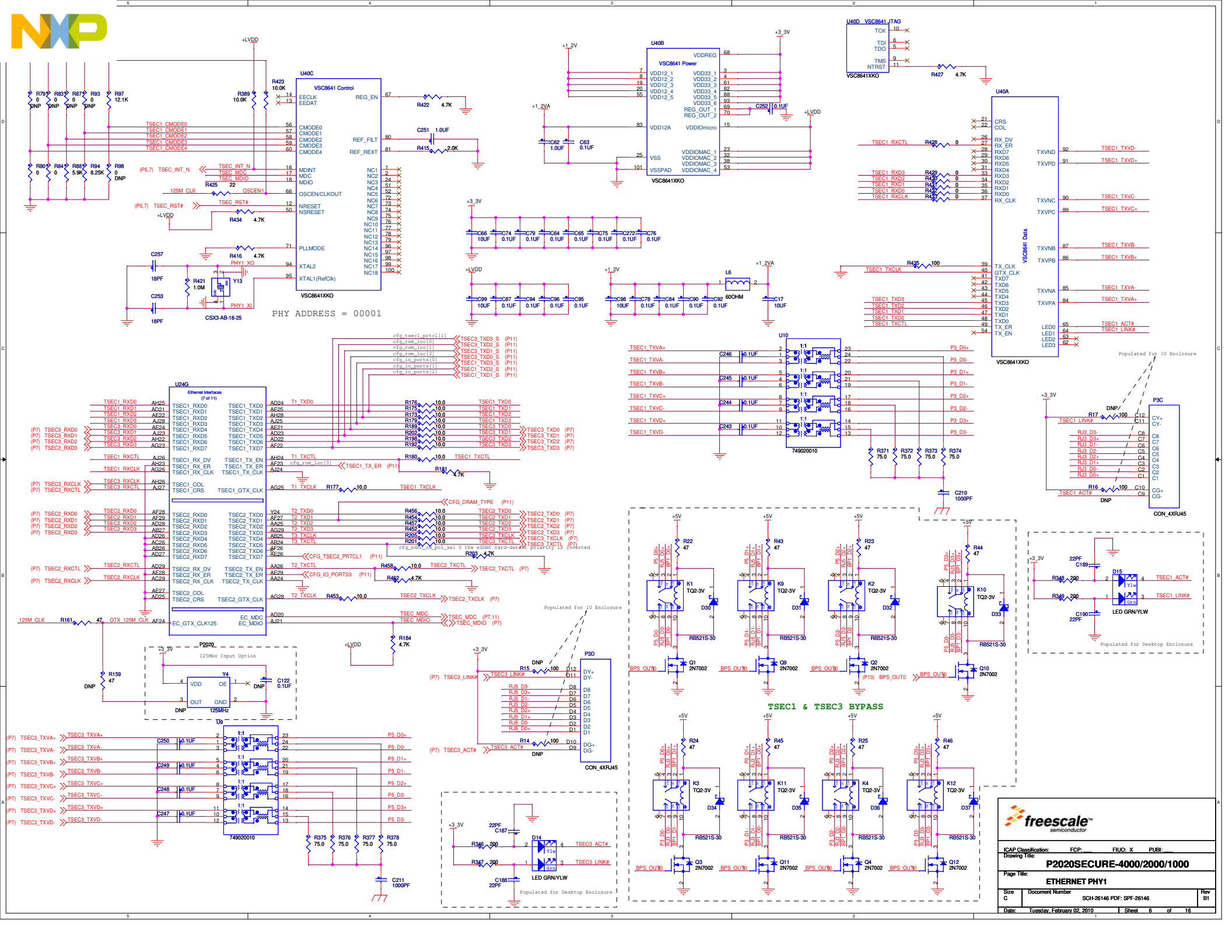

freescale
semiconductor

ICAP Classification: FCP: FIUC: X PUBI:
Drawing Title: **P2020SECURE-4000/2000/1000**

Page Title: **ETHERNET PHY1**

Size C	Document Number SCH-26146 PDF: SPF-26146	Rev B1
--------	--	--------

Date: Tuesday, February 02, 2010 Sheet 6 of 16

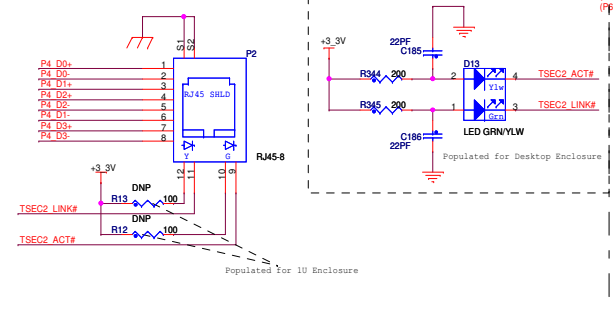
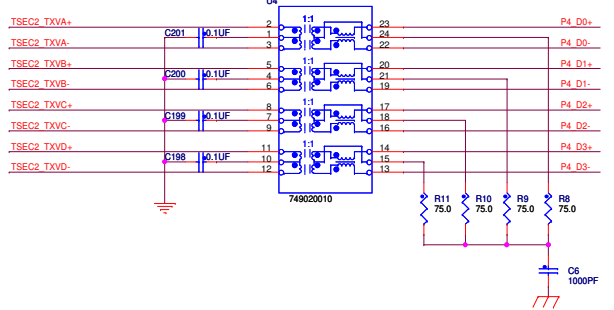
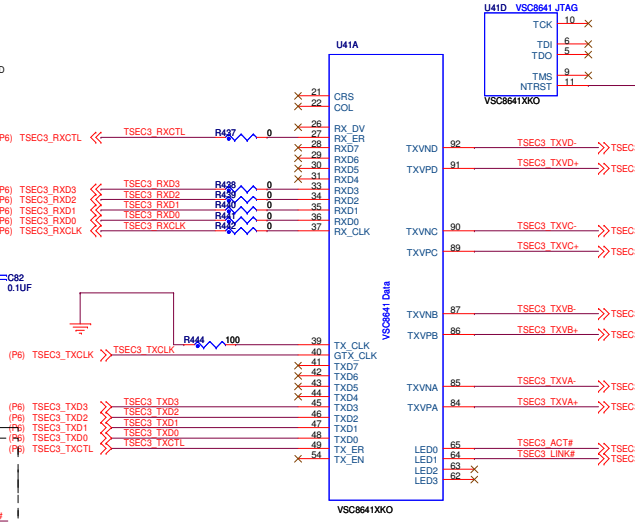
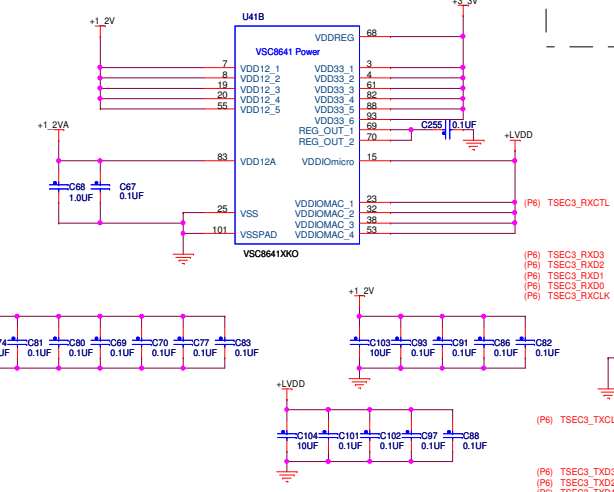
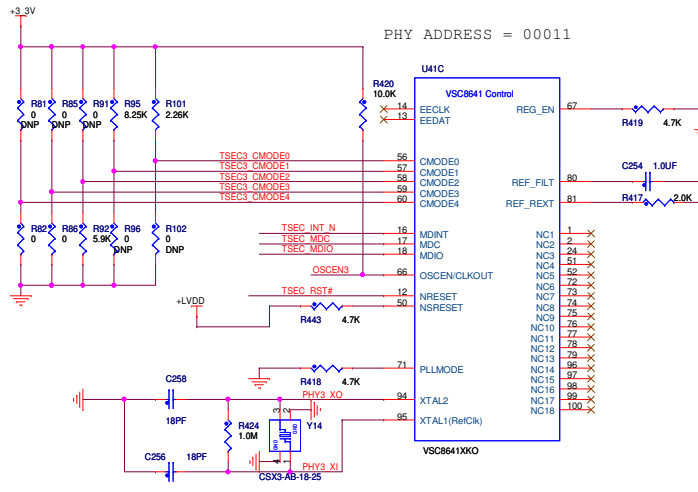
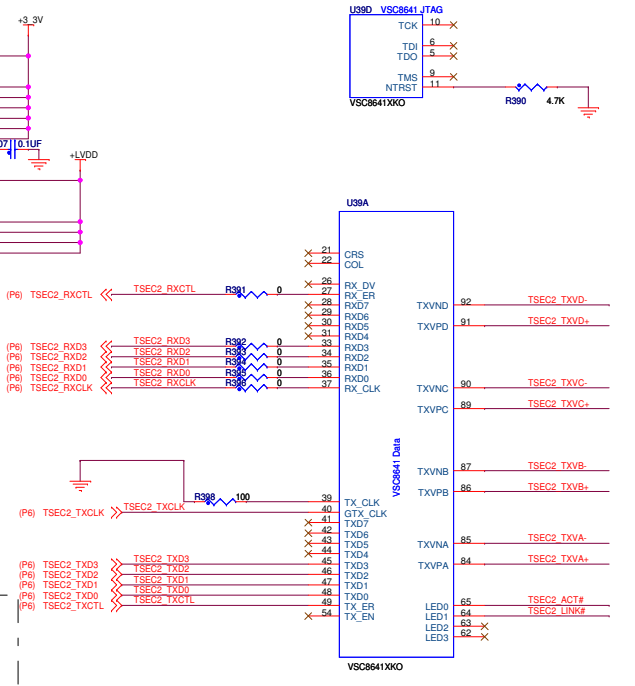
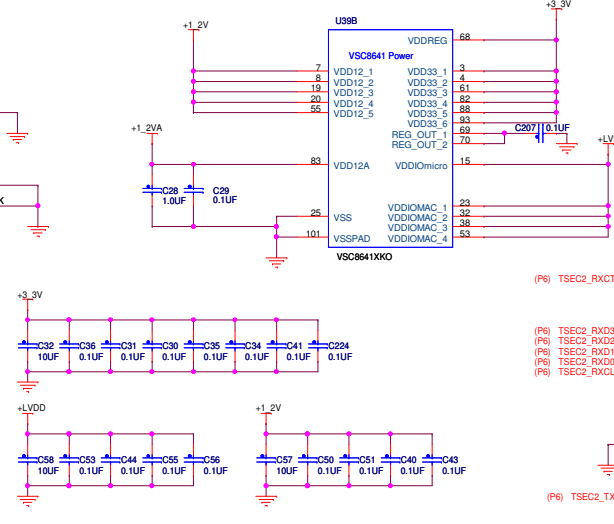
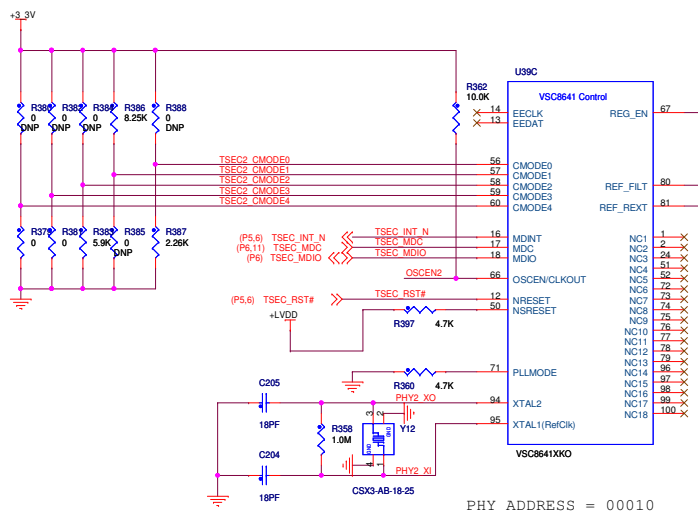

freescale
semiconductor

ICAP Classification: FCP: FIUC: X PUBI:

Drawing Title: **P2020SECURE-4000/2000/1000**

Page Title: **ETHERNET PHY2-3**

Size C Document Number SCH-26146 PDF: SPF-26146 Rev B1

Date: Tuesday, February 02, 2010 Sheet 7 of 16

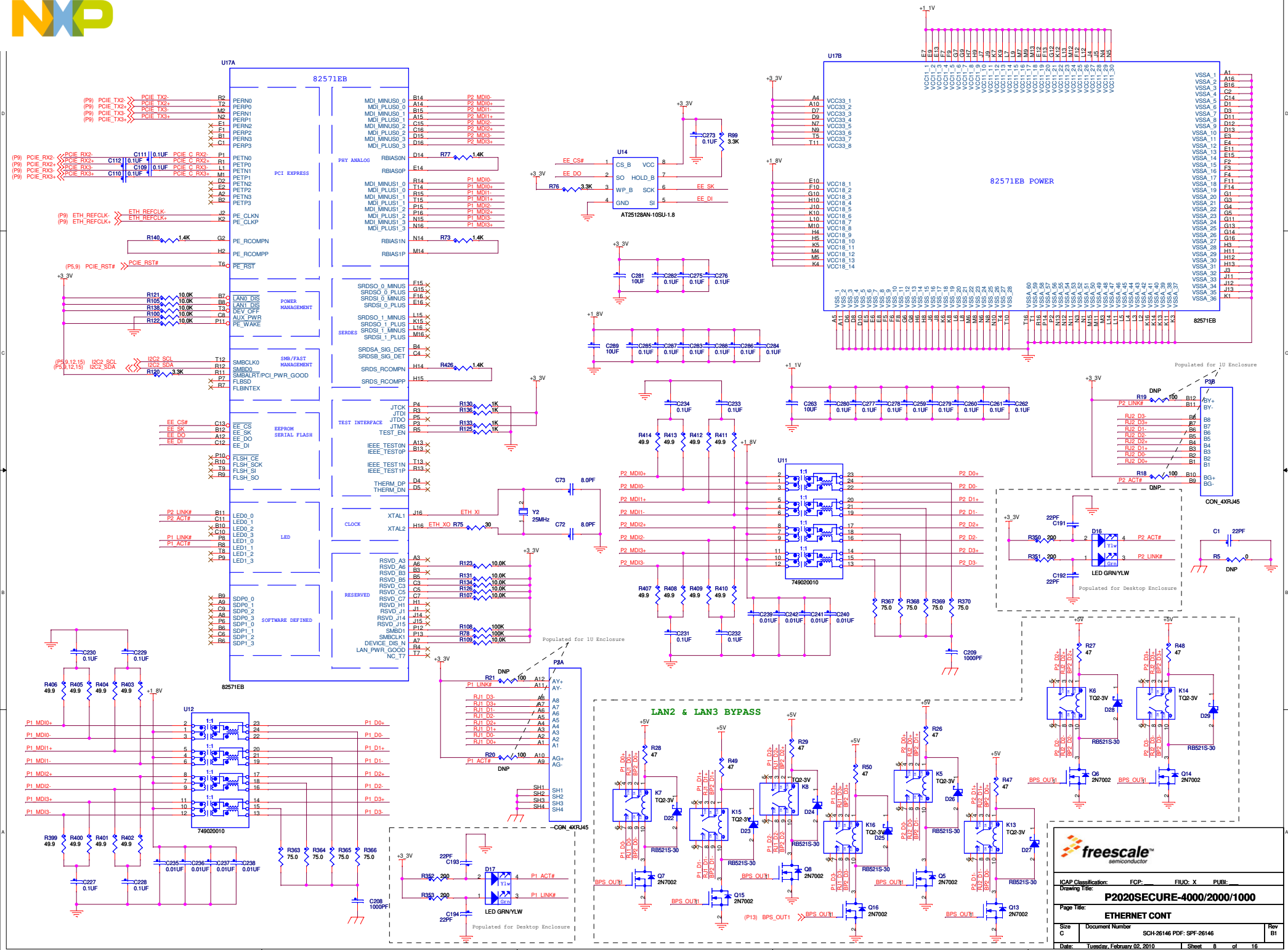

freescale
semiconductor

ICAP Classification: FCP: FIUC: X PUBI:
Drawing Title: **P2020SECURE-4000/2000/1000**

Page Title: **ETHERNET CONT**

Size C Document Number SCH-26146 PDF: SPF-26146 Rev B1

Date: Tuesday, February 02, 2010 Sheet 8 of 16

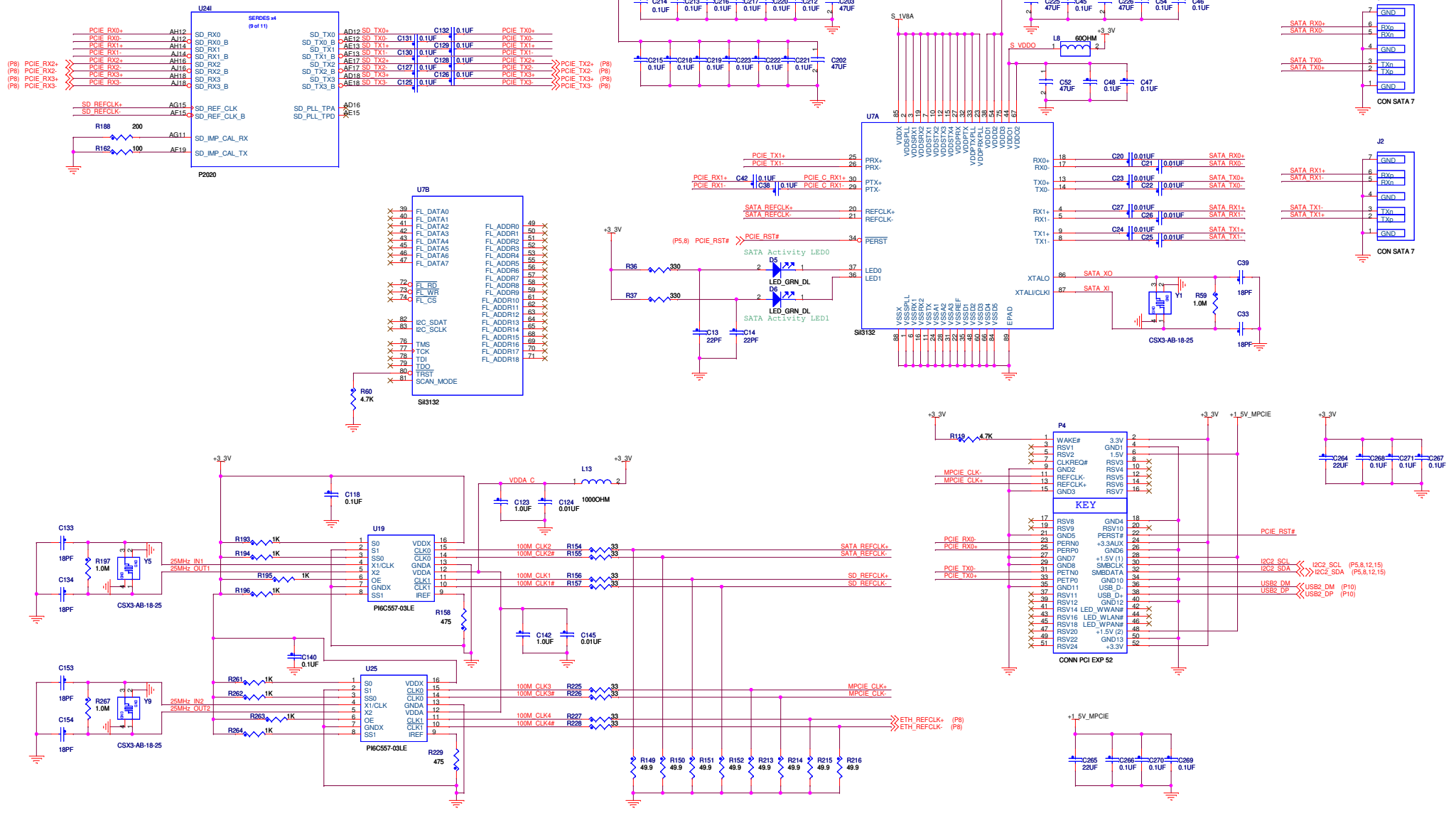

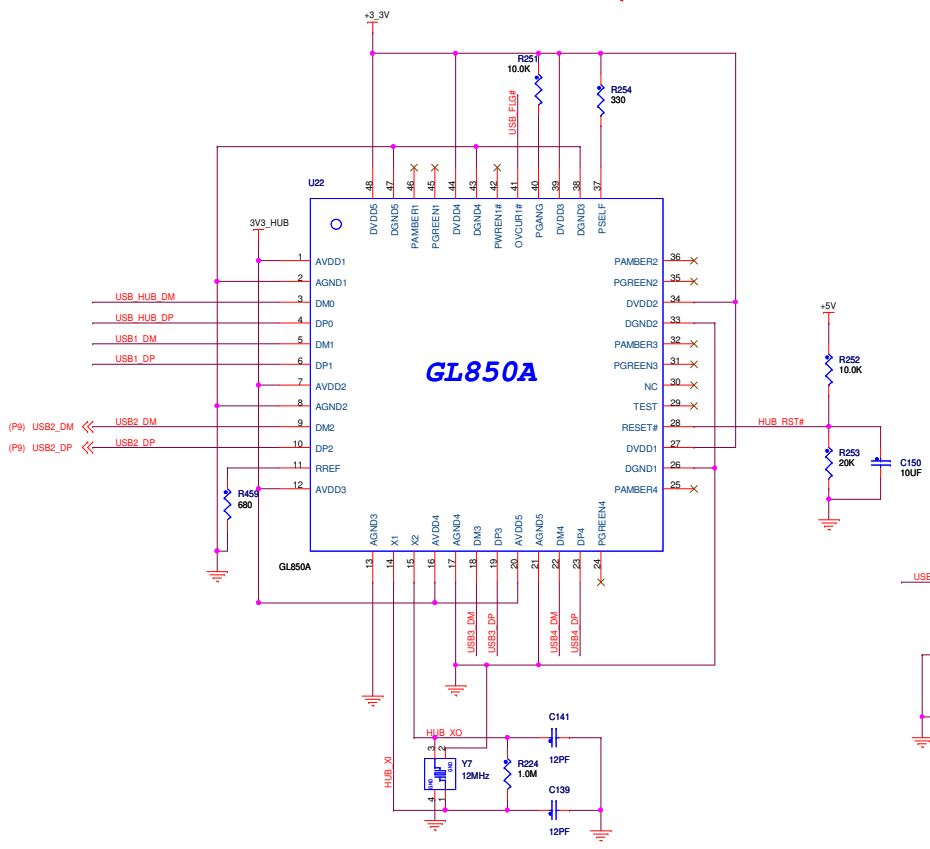
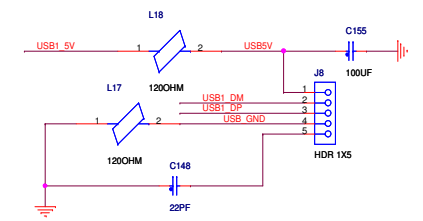
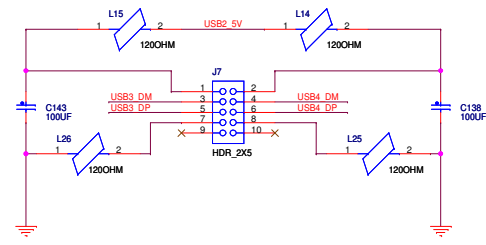
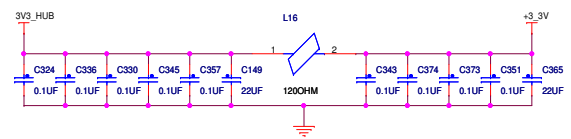
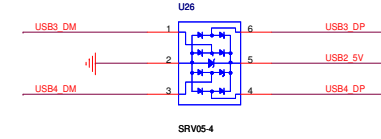
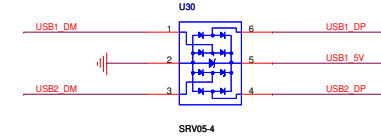
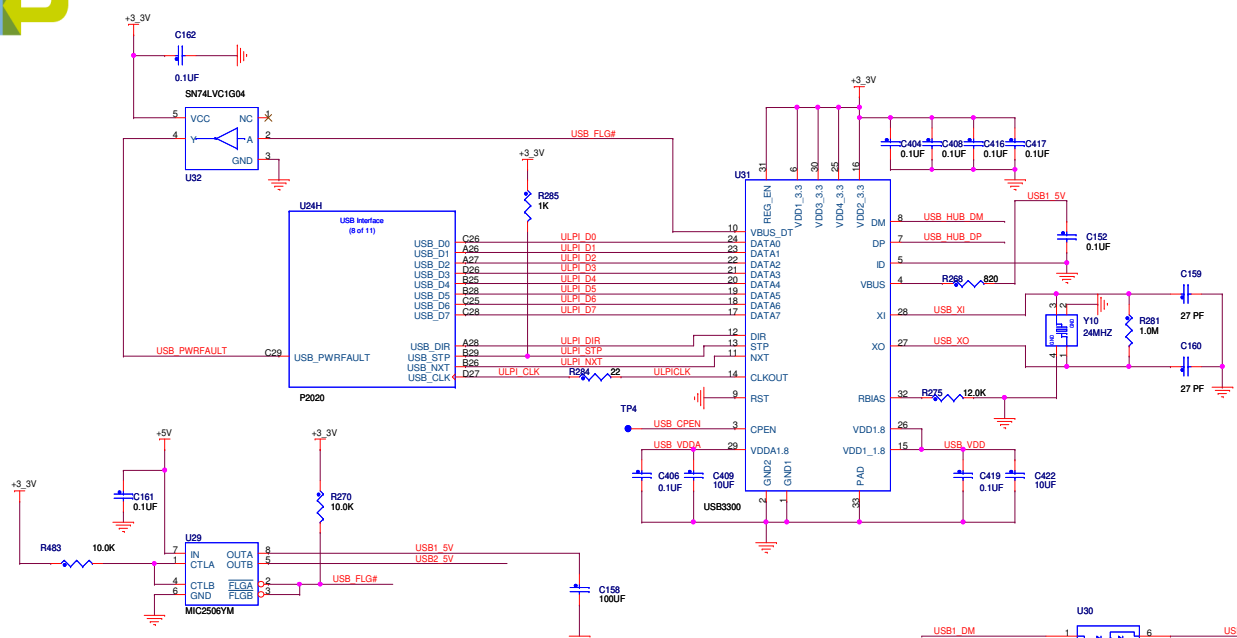

freescale
semiconductor

ICAP Classification: FCP: FIUC: X PUBI:
Drawing Title: **P2020SECURE-4000/2000/1000**
Page Title: **USB**

Size C	Document Number SCH-26146 PDF: SPF-26146	Rev B1
--------	--	--------

Date: Tuesday, February 02, 2010 Sheet 10 of 16



POR Configuration Options

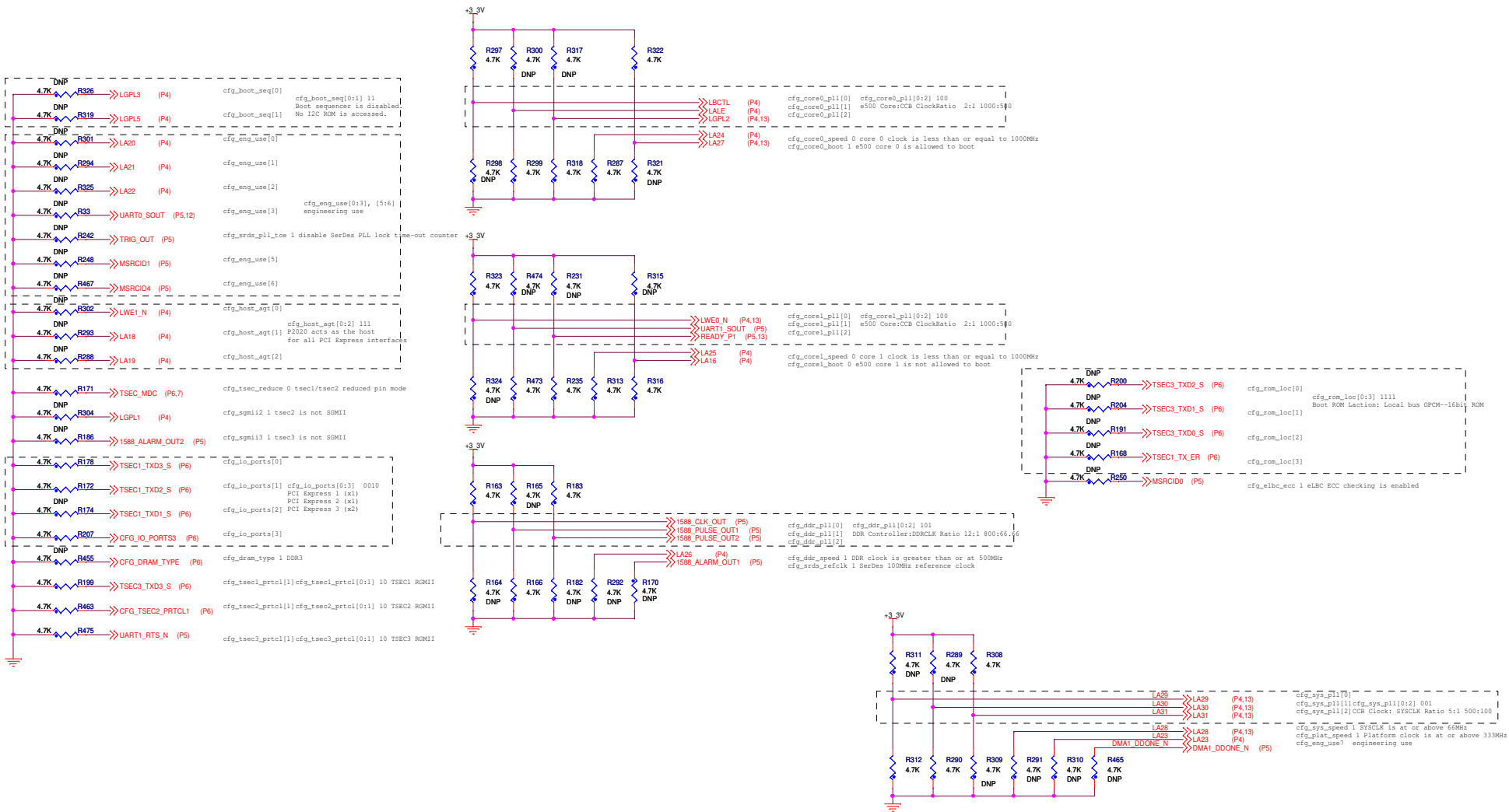

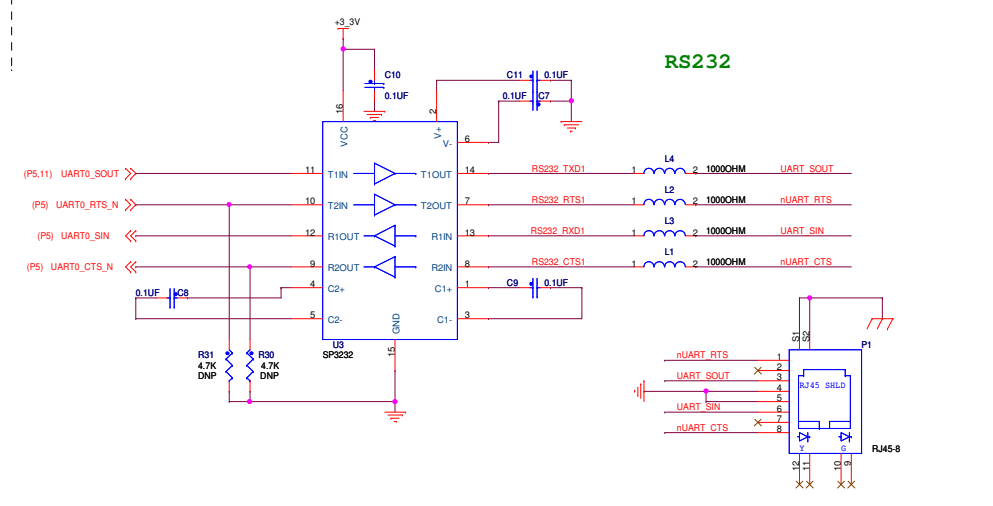
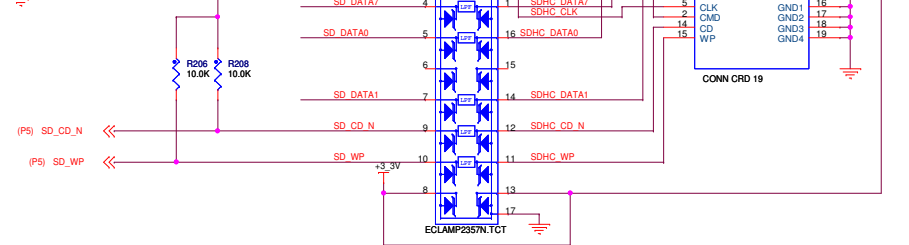
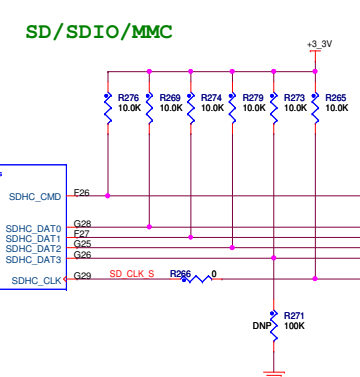
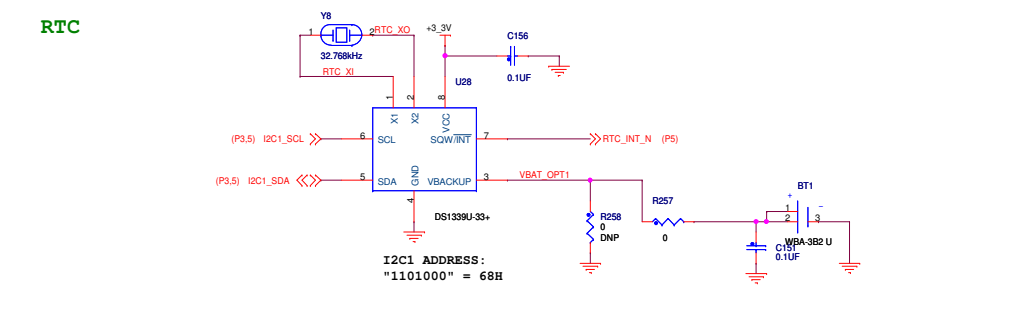
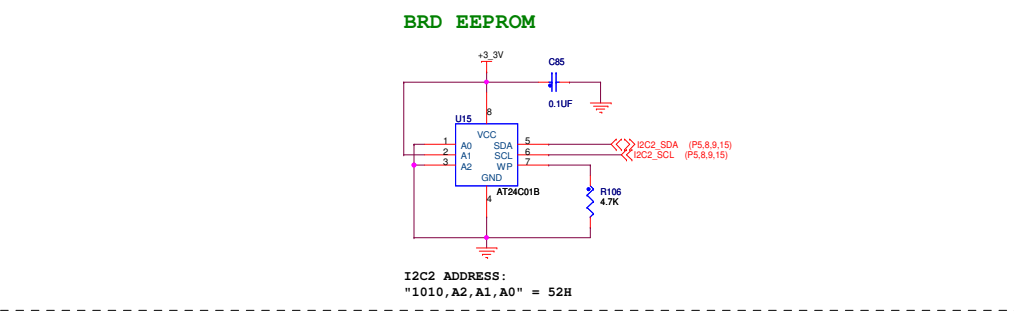
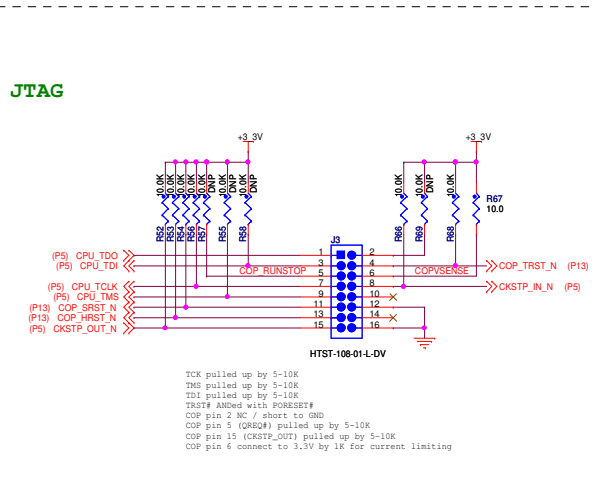
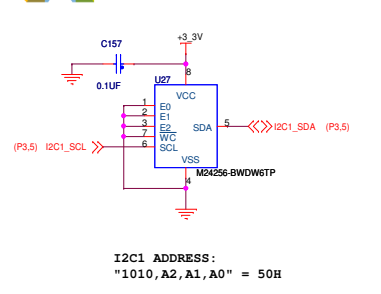

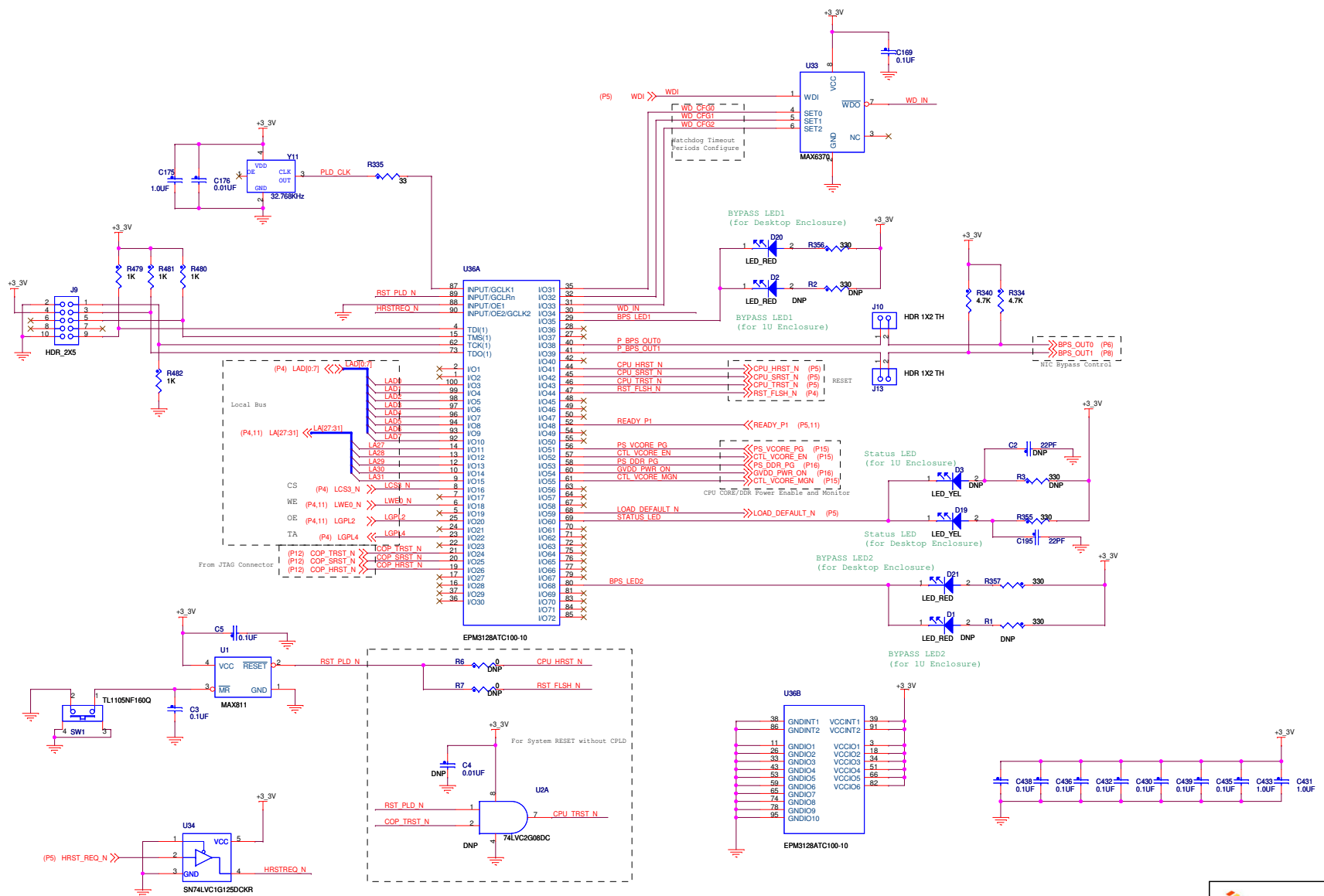

freescale
semiconductor

ICAP Classification: FCP: FIUC: X PUB: _____
Drawing Title: **P2020SECURE-4000/2000/1000**

Page Title: **CPLD**

Size C Document Number SCH-26146 PDF: SPF-26146 Rev B1

Date: Tuesday, February 02, 2010 Sheet 13 of 16



For P2020, all VDD pins are common for both single and dual core devices.

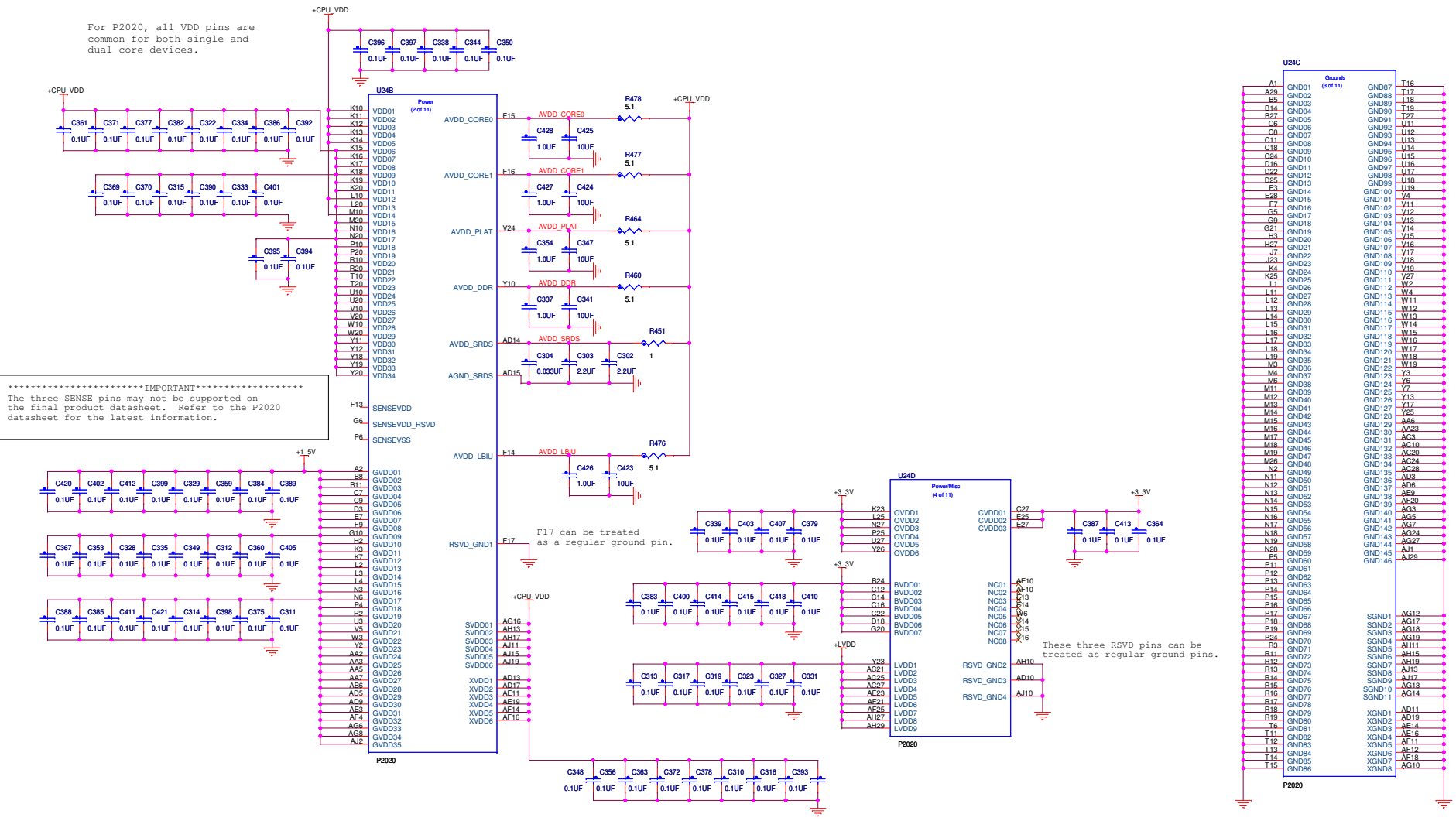

freescale
semiconductor

ICAP Classification: FCP: FIUC: X PUBI:
Drawing Title: **P2020SECURE-4000/2000/1000**

Page Title: **CPU POWER**

Size C Document Number SCH-26146 PDF: SPF-26146 Rev B1

Date: Tuesday, February 02, 2010 Sheet 14 of 16



CPU VDD POWER

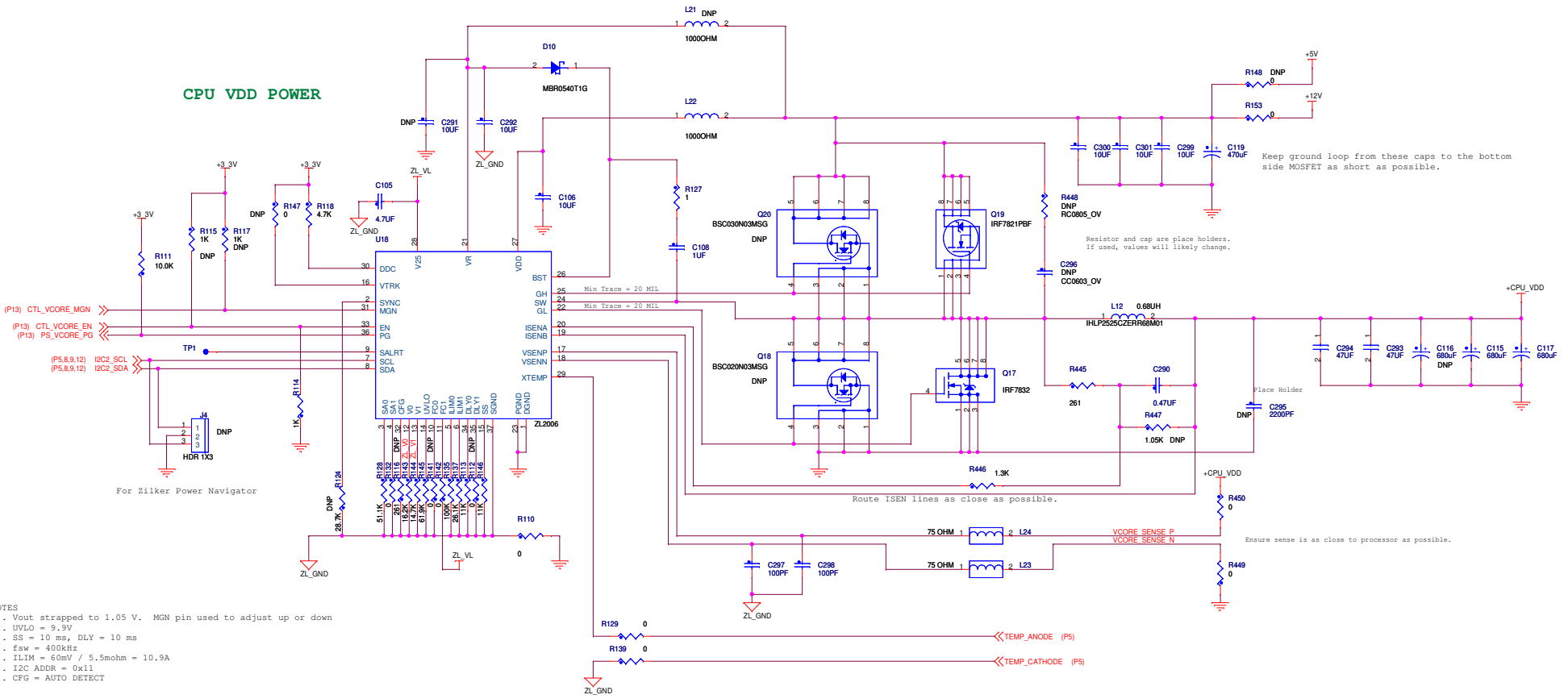

- NOTES
- 1). Vout strapped to 1.05 V. MGN pin used to adjust up or down
 - 2). UVLO = 9.9V
 - 3). SS = 10 ms, DLY = 10 ms
 - 4). Fsw = 400kHz
 - 5). I LIM = 60mV / 5.5mohm = 10.9A
 - 6). I2C ADDR = 0x11
 - 7). CFG = AUTO DETECT

freescale
semiconductor

ICAP Classification: FCP: FIUC: X PUBI:

Drawing Title: **P2020SECURE-4000/2000/1000**

Page Title: **POWER SUPPLY (CPU)**

Size C	Document Number SCH-26146 PDF: SPF-26146	Rev B1
Date: Tuesday, February 02, 2010	Sheet 15 of 16	

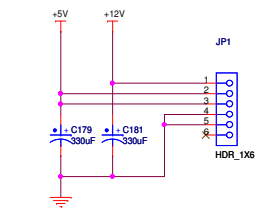
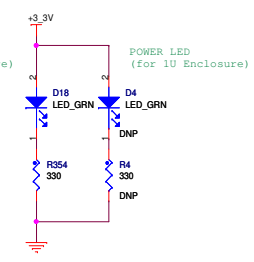
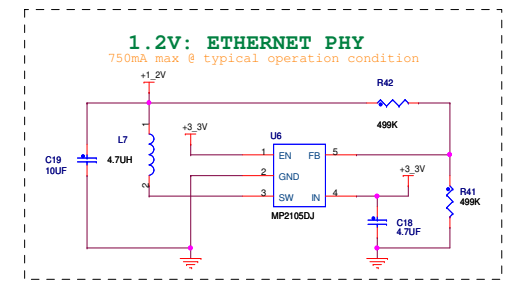
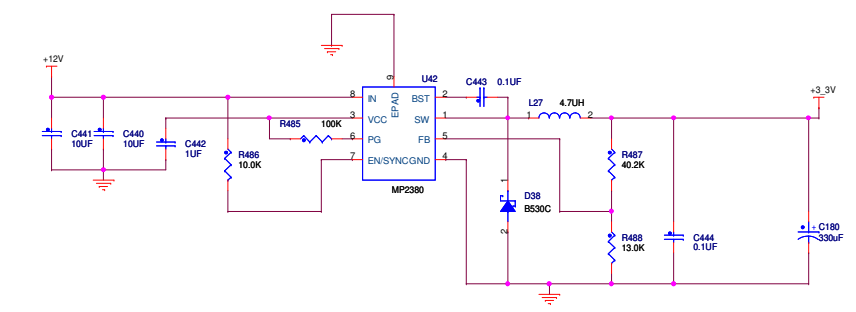
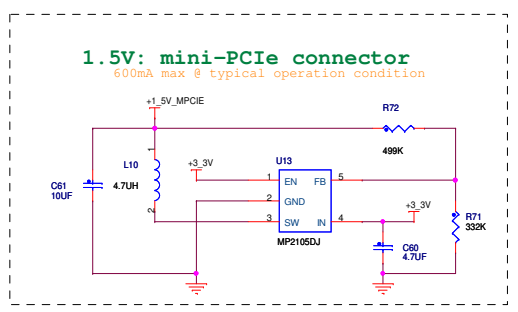
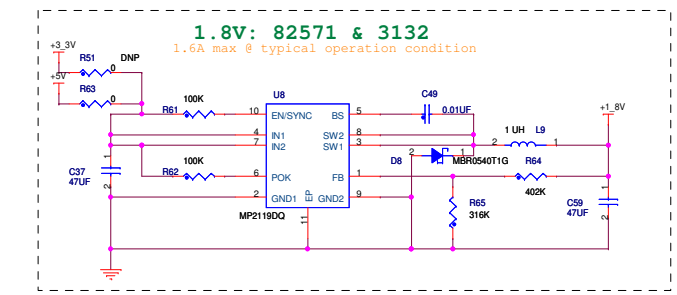
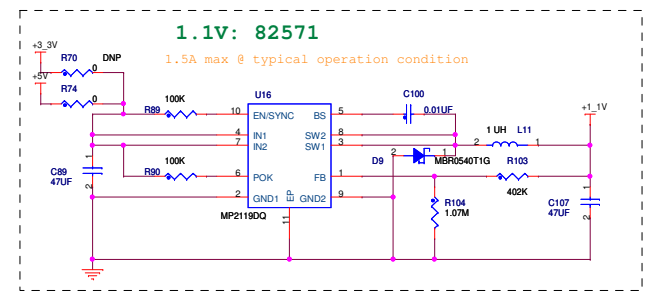
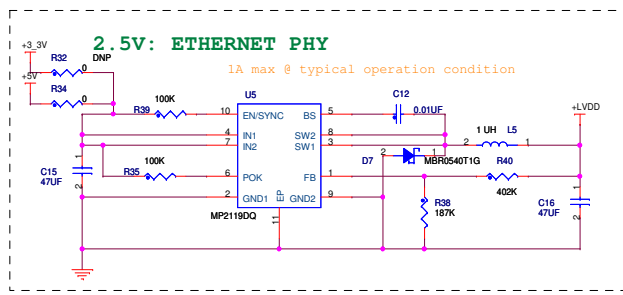
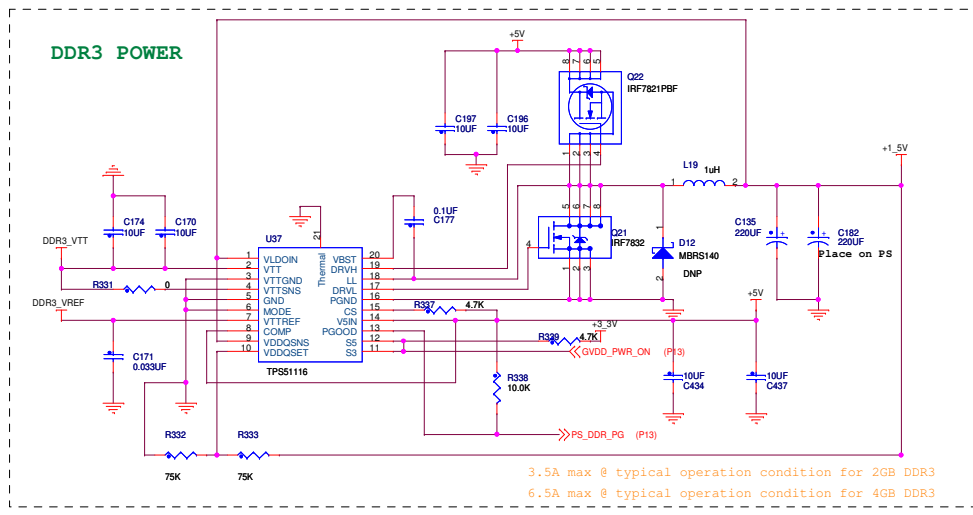

		ICAP Classification: FCP: FIUC: X PUBL:	
		Drawing Title: P2020SECURE-4000/2000/1000	
Page Title: POWER SUPPLY (MISC)			
Size C	Document Number	SCH-26146 PDF: SPF-26146	Rev B1
Date: Tuesday, February 02, 2010 Sheet 16 of 16			