

# MC56F8013 Controller Board Hardware User's Manual

---



# Table of Contents

## Preface

Audience .....	1-ix
Organization .....	1-ix
Notation Conventions .....	1-x
Definitions, Acronyms, and Abbreviations .....	1-xi
References .....	1-xii

## Chapter 1 Introduction

1.1	MC56F8013 Controller Board Architecture .....	1-2
1.2	MC56F8013 Controller Board Configuration Jumpers .....	1-3
1.3	MC56F8013 Controller Board Connections .....	1-5

## Chapter 2 Technical Summary

2.1	MC56F8013 .....	2-3
2.2	RS-232 Serial Communications .....	2-4
2.3	Clock Source .....	2-5
2.4	User LED .....	2-5
2.5	Debug Support .....	2-6
2.5.1	JTAG Connector .....	2-6
2.6	General Purpose Buttons, Reset button, and Run/Stop Switch .....	2-6
2.7	Power Supply .....	2-7
2.8	UNI-3 Interface .....	2-9
2.8.1	UNI-3 PFC PWM signal (Power Factor Correction) .....	2-10
2.8.2	UNI-3 BRAKE .....	2-10
2.9	Motor Control PWM Signals and LEDs .....	2-10
2.10	Motor Protection Logic .....	2-11
2.11	Back-EMF and Motor Phase Current Sensing .....	2-12
2.12	Quadrature Encoder/Hall-Effect Interfaces .....	2-14
2.13	Zero-Crossing Detection .....	2-14
2.14	Tacho-Generator Interface .....	2-15
2.15	Serial EEPROM .....	2-16
2.16	Peripheral Expansion Connectors .....	2-17



2.16.1	Encoder Exp. Connector . . . . .	2-17
2.16.2	Tacho-Dynamo Exp. Connector . . . . .	2-18
2.16.3	GPIO B Port Expansion Connector . . . . .	2-18
2.16.4	A/D Port Expansion Connector . . . . .	2-19
2.16.5	PWM Port Expansion Connector . . . . .	2-19
2.16.6	SPI Port Expansion Connector . . . . .	2-20
2.17	Test Points . . . . .	2-20

**Appendix A**  
**MC56F8013 Controller Board**  
**Schematics**

**Appendix B**  
**MC56F8013 Controller Board**  
**PCB**

**Appendix C**  
**MC56F8013 Controller Board**  
**Bill of Materials**

# List of Figures

1-1	Block Diagram of the MC56F8013 Controller Board . . . . .	1-2
1-2	MC56F8013 Controller Board Jumper Options . . . . .	1-3
1-3	Connecting the MC56F8013 Controller Board Cables. . . . .	1-5
2-1	Schematic Diagram of the RS-232 Interface . . . . .	2-4
2-2	Schematic Diagram of the User LED connection. . . . .	2-5
2-3	Schematic Diagram of the buttons and switch . . . . .	2-7
2-4	Power supply. . . . .	2-8
2-5	Schematic Diagram of the UNI-3 BRAKE connection . . . . .	2-10
2-6	PWM Interface and LEDs. . . . .	2-11
2-7	FAULT Protection Circuit . . . . .	2-12
2-8	ADC input selection . . . . .	2-13
2-9	Zero-Crossing/Encoder Interfaces . . . . .	2-14
2-10	Tacho-Generator Interface . . . . .	2-15
2-11	Serial EEPROM Interface. . . . .	2-16
2-12	Typical Analogue Input RC Filter . . . . .	2-19
A-1	MC56F8013 and Headers . . . . .	A-2
A-2	Serial EEPROM . . . . .	A-3
A-3	Quadrature Encoder or Hall Sensors / Zero Crossing. . . . .	A-4
A-4	Fault protection . . . . .	A-5
A-5	Jumpers . . . . .	A-6
A-6	LEDs and buttons . . . . .	A-7
A-7	Power Supply . . . . .	A-8
A-8	RS232 . . . . .	A-9
A-9	Tachogenerator . . . . .	A-10
A-10	UNI-3 connector . . . . .	A-11
B-1	TOP copper layer . . . . .	A-2
B-2	BOTTOM copper layer. . . . .	A-3



B-3	Drill copper map . . . . .	A-4
B-4	TOP silk screen layer . . . . .	A-5
B-5	TOP Board view . . . . .	A-6

# List of Tables

1-1	MC56F8013 Controller Board Jumper Options . . . . .	1-4
2-1	Serial Interface Operating Modes . . . . .	2-4
2-2	RS-232 Serial Connector Description. . . . .	2-5
2-3	JTAG Connector Description . . . . .	2-6
2-4	Connection description of the Buttons and Switch. . . . .	2-7
2-5	UNI-3 Connector Description. . . . .	2-9
2-6	ADC input source selection (ADC CFG 1) . . . . .	2-13
2-7	ADC input source selection (ADC CFG 2) . . . . .	2-13
2-8	Zero-Crossing/Encoder input source selection . . . . .	2-15
2-9	Tacho-Generator Operating Modes . . . . .	2-16
2-10	Encoder Connector Description . . . . .	2-17
2-11	Tacho-Dynamo Connector Description . . . . .	2-18
2-12	GPIO B Port Connector Description. . . . .	2-18
2-13	A/D Port Connector Description. . . . .	2-19
2-14	PWM Port Connector Description . . . . .	2-19
2-15	SPI Connector Description . . . . .	2-20





# Preface

This reference manual describes in detail the hardware on the MC56F8013 Controller Board. The board has been designed for motor/motion control demos and support specific customer needs, including the Tachodynamo hardware interface. The power supply, analogue voltage reference, and the PCB layout have been optimized for an optimum analogue performance that can not be achieved by standard EVM design, due to manufacturing restrictions and compromises.

## Audience

This document is intended for application developers who are creating software for devices using the Freescale Semiconductor part, MC56F8013.

## Organization

This manual is organized into two chapters and three appendixes.

- **Chapter 1, Introduction** - provides an overview of the Board and its features.
- **Chapter 2, Technical Summary** - describes in detail the MC56F8013 Controller Board hardware.
- **Appendix A, MC56F8013 Controller Board Schematics** - contains the schematics of the MC56F8013 Controller Board.
- **Appendix B, MC56F8013 Controller Board PCB** - contains details on the MC56F8013 Printed Circuit Board (PCB)
- **Appendix C, MC56F8013 Controller Board Bill of Materials** - provides a list of the materials used on the MC56F8013 Controller Board.

## Notation Conventions

This document uses the following conventions:

Term or Value	Symbol	Examples	Exceptions
Active High Signals (Logic One)	No special symbol attached to the signal name	MOSI SCLK	
Active Low Signals (Logic Zero)	Noted with an overbar in text and in most figures	$\overline{\text{RESET}}$ SS_B	In schematic drawings, Active Low Signals may be noted by a slash: /RESET
Hexadecimal Values	Begin with a "\$" symbol	\$0FF0 \$80	
Decimal Values	No special symbol attached to the number	10 34	
Binary Values	Begin with the letter "b" attached to the number	b1010 b0011	
Numbers	Considered positive unless specifically noted as a negative value	5 -10	Voltage is often shown as positive: +3.3V
<b>Bold</b>	Reference sources, paths, emphasis	...see: <a href="http://www.freescale.com/DSP...">http://www.freescale.com/DSP...</a>	

## Definitions, Acronyms, and Abbreviations

Definitions, acronyms, and abbreviations for terms used in this document are defined below for reference.

<b>A/D</b>	Analogue to Digital
<b>D/A</b>	Digital to Analogue
<b>DSP</b>	Digital Signal Processor
<b>EOnCE</b>	Enhanced On-Chip Emulation; a debug bus and port created by Freescale Semiconductor to enable a designer to create a low-cost hardware interface for a professional quality debug environment
<b>GPIO</b>	General Purpose Input and Output Port on Freescale Semiconductor's Family of Digital Signal Controllers
<b>IC</b>	Integrated Circuit
<b>JTAG</b>	Joint Test Action Group. A bus protocol/interface used for test and debug.
<b>LED</b>	Light Emitting Diode
<b>LQFP</b>	Low profile Quad Flat Pack
<b>MPIO</b>	Multi Purpose Input and Output port on Freescale Semiconductor's family of Digital Signal Controllers; shares package pins with other peripherals on the chip and can function as a GPIO
<b>OnCE™</b>	On-Chip Emulation, a debug bus and port created by Freescale Semiconductor to enable designers to create a low-cost hardware interface for a professional quality debug environment.
<b>PCB</b>	Printed Circuit Board
<b>PLL</b>	Phase Locked Loop
<b>PWM</b>	Pulse Width Modulation
<b>Quadrature Timer</b>	Peripheral of the MC56F801x family containing four 16-bit timers/counters with flexible architecture. See user's manual for details.
<b>Quadrature Encoder</b>	Sensor for the measurement of position and speed based on optical principles
<b>RAM</b>	Random Access Memory
<b>R/C</b>	Resistor/Capacitor Network
<b>ROM</b>	Read-Only Memory
<b>SCI</b>	Serial Communications Interface
<b>SPI</b>	Serial Peripheral Interface Port on Freescale Semiconductor's Microcontrollers
<b>UART</b>	Universal Asynchronous Receiver/Transmitter

## References

The following sources were referenced to produce this manual:

- [1] DSP56800E 16-bit DSP Core Reference Manual, Freescale Semiconductor
- [2] MC56F801x Family User's Manual, Freescale Semiconductor
- [3] MC56F8013 Digital Signal Processor Technical Data, Freescale Semiconductor

# Chapter 1

## Introduction

The MC56F8013 Controller Board is used to demonstrate the abilities of the MC56F8013 based on an optimized PCB and power supply design, and to provide a hardware tool allowing the development of applications that use the MC56F8013.

The MC56F8013 Controller Board is an evaluation module type of board that includes a MC56F8013 part, encoder interface, tachogenerator interface, communication options, digital and analogue power supplies, and peripheral expansion connectors. The expansion connectors are for signal monitoring and user feature expandability. Test pads are provided for monitoring critical signals and voltage levels.

The MC56F8013 Controller Board is designed for the following purposes:

- Allow new users to become familiar with the features of the MC56F801x architecture.
- Serve as a platform for real-time software development. The tool suite enables the user to develop and simulate routines, download the software to on-chip memory, run it, and debug using a debugger via the JTAG/OnCE™ port. The breakpoint features of the OnCE port enable the user to easily specify complex break conditions and to execute user-developed software at full-speed, until the break conditions are satisfied. The ability to examine and modify all user accessible registers, memory, and peripherals through the OnCE port greatly facilitates the task of the developer.
- Serve as a platform for hardware development. The hardware platform enables the user to connect external hardware modules. The OnCE port's unobtrusive design means that all of the memory on the Digital Signal Controller chip is available to the user.

## 1.1 MC56F8013 Controller Board Architecture

The MC56F8013 Controller Board facilitates the evaluation of various features present in the MC56F8013. The MC56F8013 Controller Board can be used to develop real-time software and hardware products based on the MC56F8013. The MC56F8013 Controller Board provides the features necessary for a user to write and debug software, demonstrate the functionality of that software, and interface with the customer's application-specific device(s). The MC56F8013 Controller Board is flexible enough to allow a user to fully exploit the MC56F8013's features to optimize the performance of their product, as shown in [Figure 1-1](#).

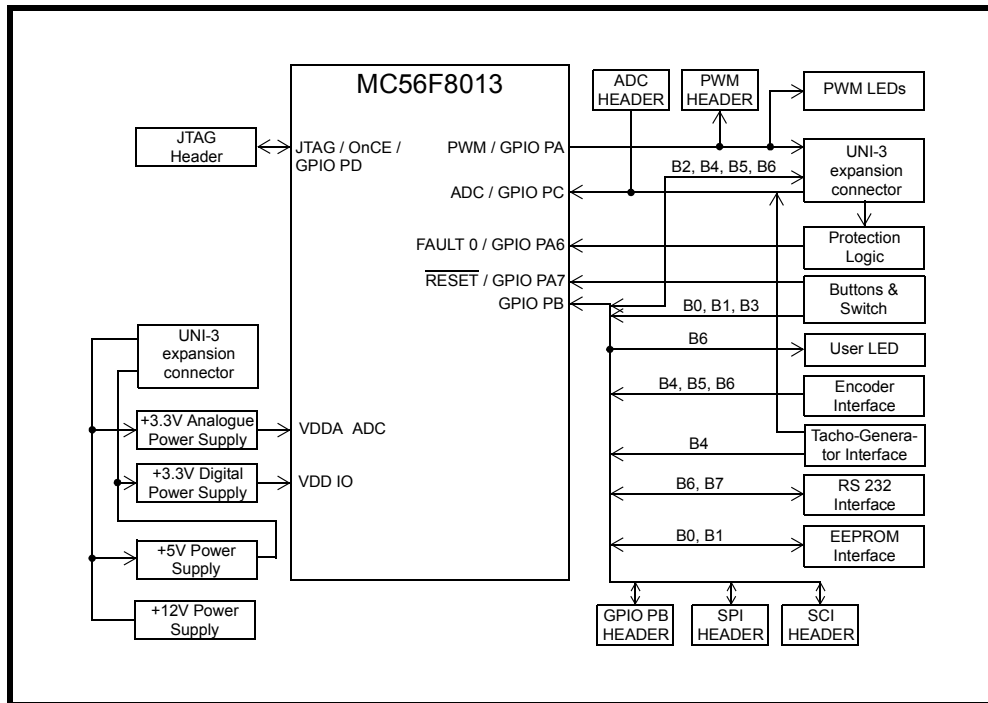
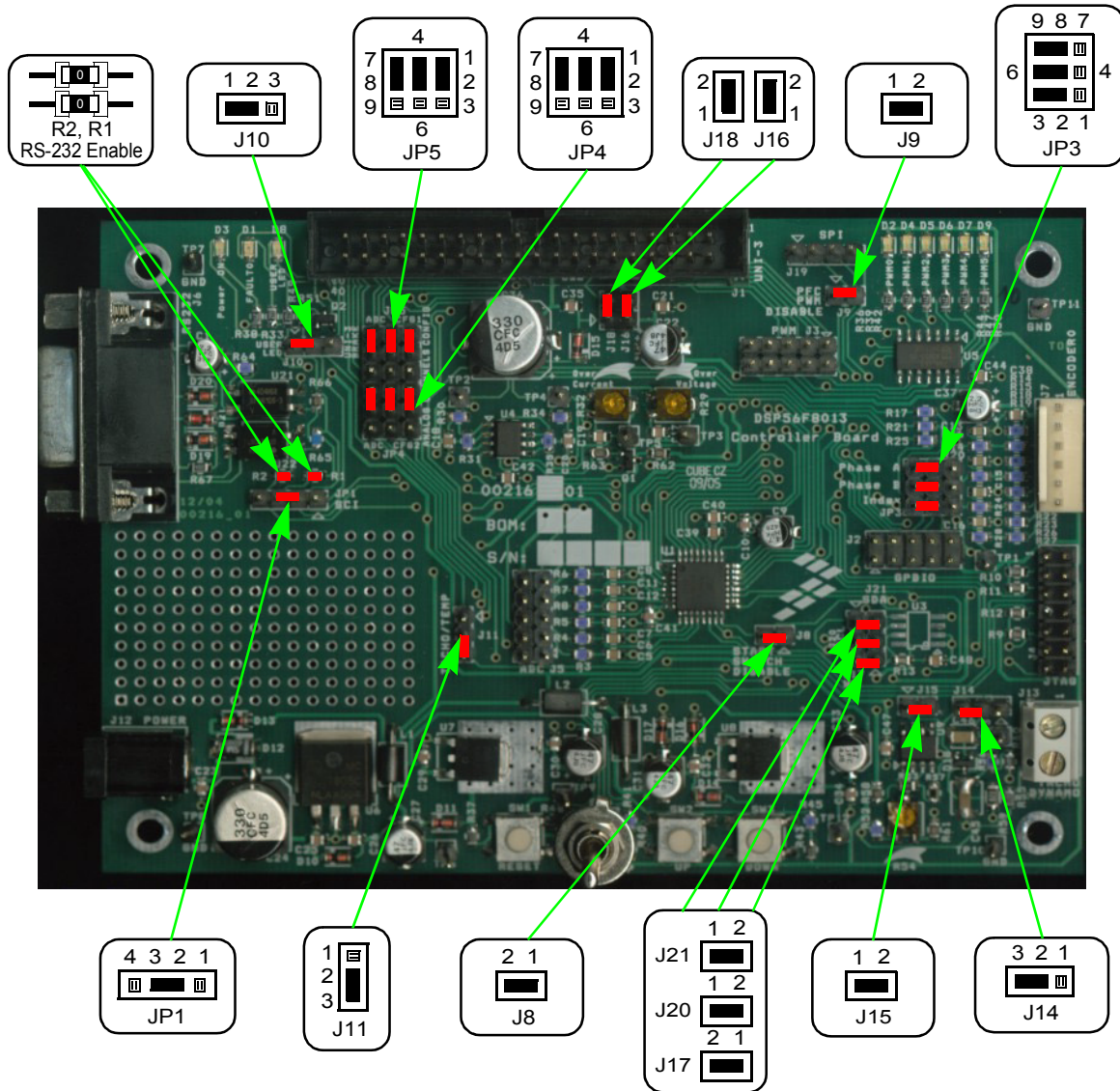

Figure 1-1. Block Diagram of the MC56F8013 Controller Board

## 1.2 MC56F8013 Controller Board Configuration Jumpers

Jumper groups and zero Ohm resistors<sup>1</sup>, shown in [Figure 1-2](#), are used to configure various features on the MC56F8013 Controller Board.



**Figure 1-2. MC56F8013 Controller Board Jumper Options**

1. Zero Ohm resistors are used instead of standard jumpers to minimize distortion of analogue signals and to achieve high signal-to-noise ratio.

**Table 1-1. MC56F8013 Controller Board Jumper Options**

#	Selector	Function	Connections
JP1	SCI	Configure RxD (GPIO PB6) as Encoder INDEX / UNI-3 BEMFZCC input	open
		Configure RxD (GPIO PB6) as User LED / UNI-3 BRAKE output	1-2
		Full-duplex Serial mode	2-3
		Single wire Serial communication mode (TxD as serial I/O)	3-4
	R1, R2	RS 232 interface disabled	R1, R2 absent
		RS 232 interface enabled	R1, R2 present
JP3	Encoder / UNI-3 BEMFZCx	Q-Encoder / Hall-Effect interface selected (PHASEA, PHASEB, INDEX)	1-2, 4-5, 7-8
		Zero-Crossing signals selected (BEMFZCA, BEMFZCB, BEMFZCC)	2-3, 5-6, 8-9
JP4	PHAIS/BEMFA / V_IN	PHAIS / BEMFA measurement selected	1-2
		V_IN measurement selected	2-3
	PHBIS/BEMFB / I_IN	PHBIS / BEMFB measurement selected	4-5
		I_IN measurement selected	5-6
	PHCIS/BEMFC / TEMP	PHCIS / BEMFC measurement selected	7-8
		TEMP measurement selected	8-9
JP5	PHAIS / BEMFA	Phase A current measurement selected	1-2
		Phase A back EMF measurement selected	2-3
	PHBIS / BEMFB	Phase B current measurement selected	4-5
		Phase B back EMF measurement selected	5-6
	PHCIS / BEMFC	Phase C current measurement selected	7-8
		Phase C back EMF measurement selected	8-9
J8	START Switch Disable <sup>1</sup>	START Switch connected to GPIO PB3 (MOSI / T3)	closed
J9	PFC PWM Disable <sup>1</sup>	UNI-3 PFC PWM connected to GPIO PB2 (MISO / T2)	closed
J10	USER LED / UNI-3 BRAKE	USER LED output selected	1-2
		UNI-3 BRAKE output selected	2-3
J11	TACHO / TEMP	UNI-3 TEMP -> ANA2 measurement selected	1-2
		TACHO -> ANA2 measurement selected	2-3
J14	Tacho dynamo measurement	Tacho Dynamo input -> TACHO analogue output (ANA2)	1-2
		Tacho Dynamo input -> digital output (GPIO PB4)	2-3



**Table 1-1. MC56F8013 Controller Board Jumper Options**

#	Selector	Function	Connections
J15	Tacho generator output enable	Tacho generator digital output enabled (GPIO PB4)	closed
J16	UNI-3 +5V	CB digital power supply from UNI-3 +5V	closed
J18	UNI-3 +15V	CB analogue power supply from UNI-3 +15V	closed
J17	WP	Serial EEPROM memory is write protected	open
		Serial EEPROM memory is write unprotected	closed
J20	SCL	Serial EEPROM memory SCL input connected to GPIO PB0 / SCLK / SCL	closed
J21	SDA	Serial EEPROM memory SDA I/O connected to GPIO PB1 / $\overline{SS}$ / SDA	closed

- Note: JP8 & JP9 have the name with the 'Disable' printed on the board. These signals are enabled when jumpers are closed, disabled when open!

### 1.3 MC56F8013 Controller Board Connections

An interconnection diagram is shown in [Figure 1-3](#) for connecting the PC and the external 12V DC power supply to the MC56F8013 Controller Board.

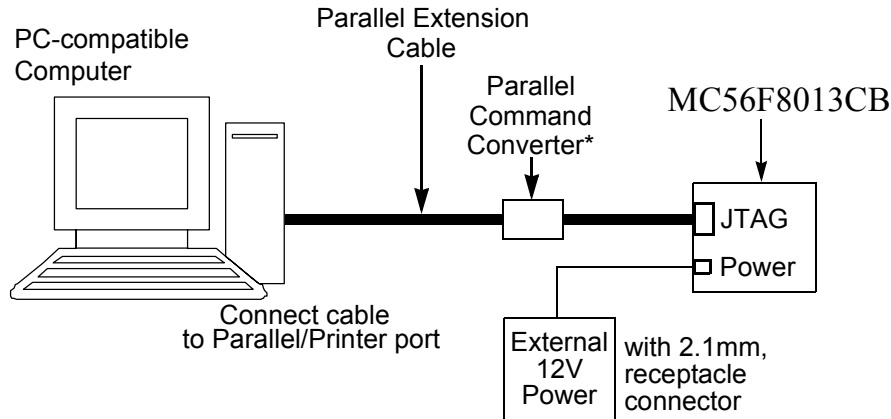

\* use of optoisolated PCC is recommended for high voltage applications

**Figure 1-3. Connecting the MC56F8013 Controller Board Cables**

When optoisolation is needed in the development environment to isolate the computer from the motor driver board and the Controller Board, use the optoisolated parallel command converter (ECOPTINL) instead of the non-isolated parallel command converter (DSPCOMM PARALLEL). In addition, command converters with ISA, PCI, USB, and ETHERNET interfaces are available.

Perform the following steps to connect the MC56F8013 Controller Board cables:

1. Connect the parallel extension cable to the Parallel port of the host computer.
2. Connect the other end of the parallel extension cable to the Parallel Command Converter, shown in [Figure 1-3](#), and connect it to the JTAG header on the MC56F8013 Controller Board. Please make sure that pin 1 on the Command Converter is aligned with pin 1 on the Controller Board. This provides the connection which allows the host computer to control the board.
3. Connect the 2.1mm output power plug from the external power supply into the Power Jack, shown in [Figure 1-3](#), on the MC56F8013 Controller Board.
4. Apply power to the external power supply. The green Power-On LED will illuminate when power is correctly applied.

## Chapter 2

# Technical Summary

The MC56F8013 Controller Board is designed as a versatile development card, for developing real-time software and hardware products to support a new generation of applications in servo and motor control, SMPS, modems, and digital cameras. The power of the 16/32-bit MC56F8013 Digital Signal controller, combined with the Hall-Effect/Quadrature Encoder interface, Tacho-generator interface for digital/analogue sensing, motor BEMF zero crossing interface, motor over-current logic and motor over-voltage logic, makes the MC56F8013 Controller Board ideal for developing and implementing many motor controlling algorithms, as well as for learning the architecture and instruction set of the MC56F8013 processor.

The main features of the MC56F8013 Controller Board include:

- MC56F8013 16/32-bit +3.3V Digital Signal Processor operating at 32MHz
- Joint Test Action Group (JTAG) port interface connector for an external debug Host Target Interface
- RS-232 interface with galvanic isolation for easy connection to a host computer or PC Master development tool
- Connector to allow the user to attach their own SPI / GPIO compatible peripheral
- Connector to allow the user to attach their own SCI / GPIO compatible peripheral
- Connector to allow the user to attach their own PWM compatible peripheral
- Connector to allow the user to attach their own ADC compatible peripheral
- Connector to allow the user to attach their own GPIO Port B compatible peripheral
- On-board power regulation from an external 12V DC supplied power input
- Light Emitting Diode (LED) power indicator
- Six on-board PWM monitoring LEDs
- One on-board PWM Fault monitoring LED
- One on-board general purpose User LED

- UNI-3 Motor interface
  - Over-Voltage sensing
  - Over-Current sensing
  - Phase Current sensing
  - Back-EMF sensing
  - Temperature sensing
  - Zero Crossing detection
  - Pulse Width Modulation
  - BRAKE, PFC PWM signals
- Encoder/Hall-Effect interface
- Tacho dynamo interface
- Manual RESET/General purpose push-button on GPIO PA7
- General purpose push-button for UP on GPIO PB0
- General purpose push-button for DOWN on GPIO PB1
- General purpose toggle switch for RUN/STOP control on GPIO PB3 via J8

## 2.1 MC56F8013

The MC56F8013 Controller Board uses a Freescale Semiconductor part, MC56F8013VFAE, designated as U1 on the board and in the schematics. This part will operate at a maximum speed of 32MHz. A full description of the MC56F8013, including functionality and user information, is provided in the following documents:

- *MC56F8013 Technical Data Sheet, (MC56F8013/D)*: Provides features list and specifications including signal descriptions, electrical and timing specifications, pin descriptions, device specific peripheral information, and package descriptions.
- *MC56F8013 User's Manual, (MC56F8013UM/D)*: Provides an overview description of the Digital Signal Controller and detailed information about the on-chip components, including the memory and I/O maps, peripheral functionality, and control/status register descriptions for each subsystem.
- *DSP56800E 16-bit DSP Core Reference Manual, (DSP56800ERM/D)*: Provides a detailed description of the processor core, including internal status and control registers, and a detailed description of the family instruction set.

Refer to these documents for detailed information about chip functionality and operation. They can be found on this URL:

**[www.freescale.com/dsp](http://www.freescale.com/dsp)**

## 2.2 RS-232 Serial Communications

The MC56F8013 Controller Board provides an RS-232 interface by the use of an RS-232 level converter circuitry, referred to in the RS-232 schematic diagram in **Figure 2-1**. The RS-232 level converter transitions the SCI UART's +3.3V signal levels to RS-232 compatible signal levels and connects to the host's serial port via the DB9F connector. The pinout of the RS232 connector is listed in **Table 2-2**. To enable proper working of the serial interface, the zero Ohm link resistors R1 and R2 must be present on the Controller Board and jumper JP1 must be set correctly. For full-duplex mode, the JP1 jumper has to be set to position 2-3, for single wire operation, the JP1 jumper has to be set to position 3-4, then the RxD pin on the MC56F8013 controller is not used for the serial communication and can be used as a general purpose input/output pin (GPIO PB6). When full-duplex serial communication mode is selected, the JP3 jumper selection of Encoder INDEX / UNI-3 BEMFZCC signals must be disconnected to avoid hazardous states, as shown in **Figure 2-1**. **Table 2-1** shows the jumper setting for two operating modes of serial interface.

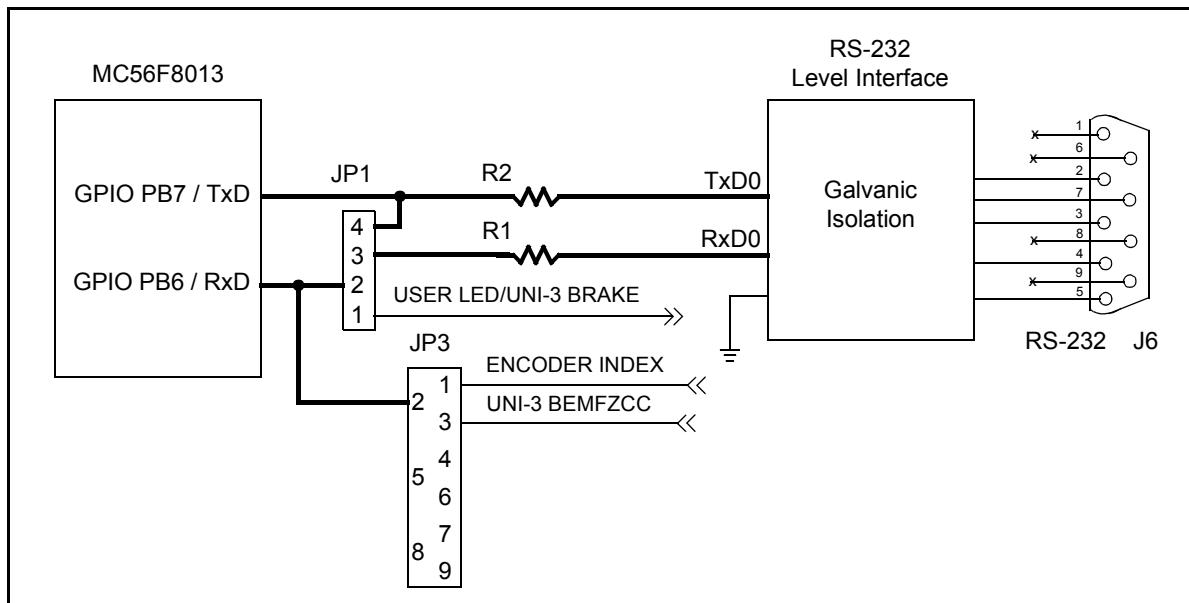

**Figure 2-1. Schematic Diagram of the RS-232 Interface**

**Table 2-1. Serial Interface Operating Modes**

JP1	Operating Mode
2-3	Full-duplex mode, uses RxD as input and TxD as output on MC56F8013
3-4	Single wire mode, uses only TxD as I/O for serial communication on MC56F8013, RxD can be used as General Purpose I/O (GPIO PB6)

**Table 2-2. RS-232 Serial Connector Description**

J6			
Pin #	Signal	Pin #	Signal
1	NC	6	NC
2	RxD	7	RTS
3	TxD	8	NC
4	DTR	9	NC
5	GND		

## 2.3 Clock Source

The MC56F8013 uses its internal 8.00MHz relaxation oscillator and internal PLL to multiply the input frequency to achieve its 32MHz maximum operating frequency.

## 2.4 User LED

One on-board Light-Emitting green colour Diode (LED) D8 is provided to be controlled by the user's program. This diode is accessible via GPIO PB6 port (RxD), when jumpers JP1 and J10 are both set to position 1-2. Setting GPIO PB6 (RxD) to a Logic One value will turn on the User LED. When using the User LED, the JP3 jumper selection of Encoder INDEX / UNI-3 BEMFZCC signals must be disconnected to avoid hazardous states, as shown in [Figure 2-2](#).

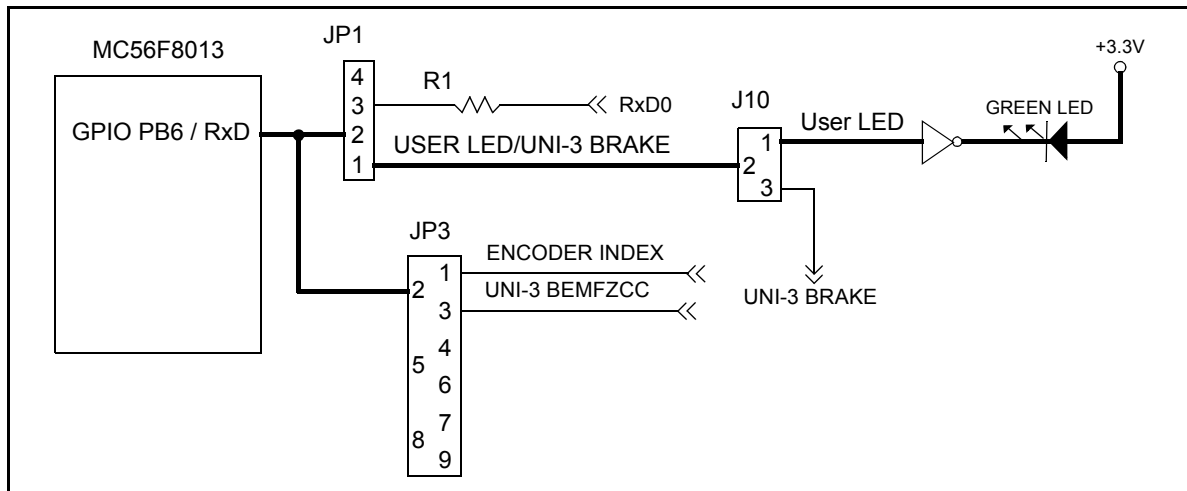
**Figure 2-2. Schematic Diagram of the User LED connection**

## 2.5 Debug Support

The MC56F8013 Controller Board has a JTAG interface connector for external Target Interface support.

### 2.5.1 JTAG Connector

The JTAG connector on the MC56F8013 Controller Board allows the connection of an external Host Target Interface for downloading programs and working with the MC56F8013's registers. This connector is used to communicate with an external Host Target Interface passing information and data back and forth to a host processor running a debugger program. [Table 2-3](#) shows the pin-out for this connector.

**Table 2-3. JTAG Connector Description**

J4			
Pin #	Signal	Pin #	Signal
1	TDI	2	GND
3	TDO	4	GND
5	TCK	6	GND
7	NC	8	NC
9	$\overline{\text{RESET}}$	10	TMS
11	+3.3V	12	NC
13	/DE	14	NC

## 2.6 General Purpose Buttons, Reset button, and Run/Stop Switch

Three on-board push-button switches and one toggle switch are provided for the user's program control. Two push-buttons (UP, Down) are directly connected to the Port B GPIO signals PB0 (UP/SW2) and PB1 (DOWN/SW3). One push-button (RESET/SW1) is provided for setting the MC56F8013  $\overline{\text{RESET}}$  input pin to logic level Low. This pin can also be configured as Port A GPIO PA7. A Run/Stop toggle switch is connected to GPIO signal PB3 through the J8 jumper, which has to be closed, see table [Table 2-4](#) for the signal description. Note that signals from the UP and DOWN buttons are shared with the Serial EEPROM memory signals (GPIO PB0 / SCL and GPIO PB1 / SDA). The Serial EEPROM memory communication should be disabled by opening the jumpers J20 and J21, as shown in [Figure 2-3](#). Button UP and switch RUN/STOP are connected to the



controller's input pins, which are shared with the SPI (Serial Peripheral Interface) header. While using SPI communication, jumper J8 should be opened and button UP should not be used.

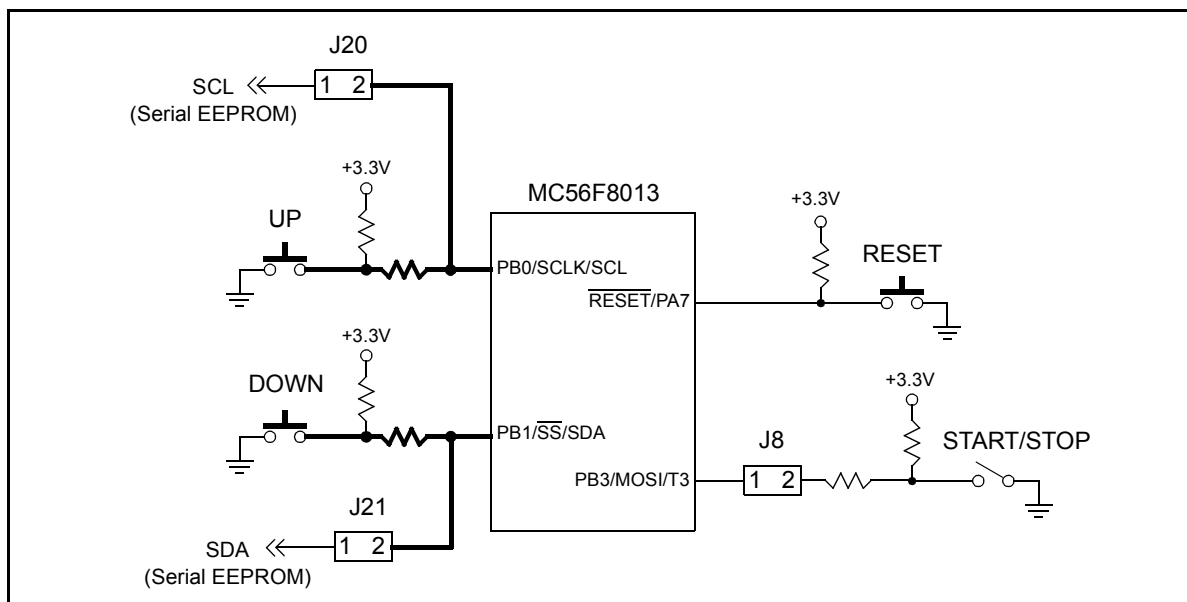

**Figure 2-3. Schematic Diagram of the buttons and switch**

**Table 2-4. Connection description of the Buttons and Switch**

SWITCH	SIGNAL
RESET (SW1)	$\overline{\text{RESET}}$ / GPIO PA7
UP (SW2)	GPIO PB0 / SCLK / SCL
DOWN (SW3)	GPIO PB1 / $\overline{\text{SS}}$ / SDA
RUN/STOP (SW4)	GPIO PB3 / MOSI / T3 (jumper J8 is closed)

## 2.7 Power Supply

The main power supply input 12V DC to the MC56F8013 Controller Board is through a 2.1mm coax power jack. Less than 12V is required by the Controller Board, with the remaining current available to the user via the on board connectors. The MC56F8013 Controller Board provides +3.3V DC voltage regulation for the Digital Signal Controller and supporting logic. Power applied to the MC56F8013 Controller Board is indicated by a

Power-On LED. The Controller Board can also be powered from the UNI-3 interface by closing the J16 and J18 jumpers, as shown in **Figure 2-4**.

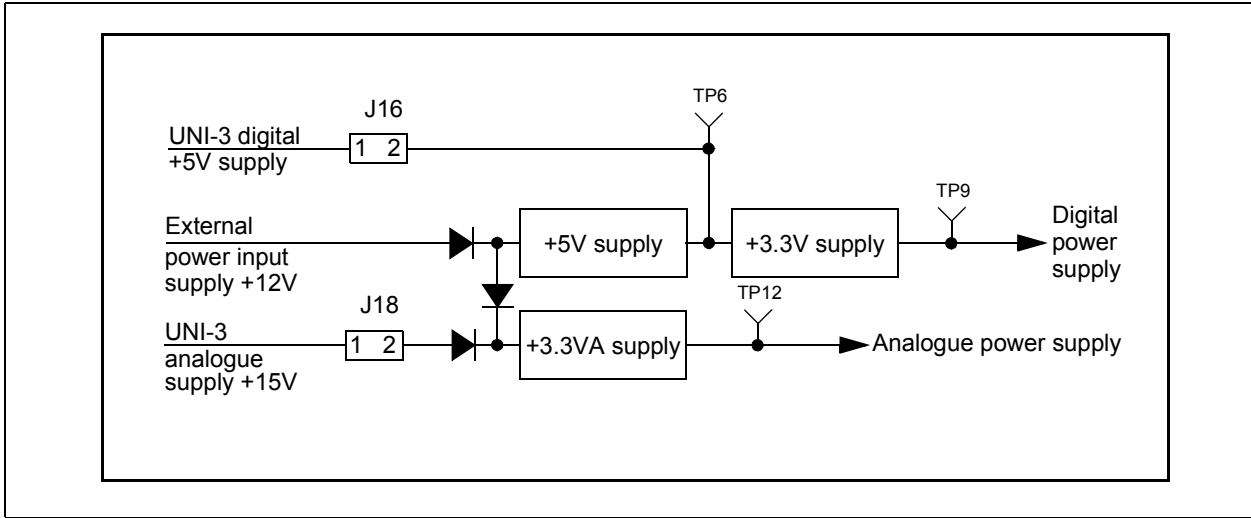

**Figure 2-4. Power supply**

## 2.8 UNI-3 Interface

Motor control signals from a family of motor driver boards can be connected to the board via the UNI-3 connector/interface. The UNI-3 connector/interface contains all of the signals needed to drive and control the motor drive boards. These signals are connected to differing groups of the Digital Signal Controller's input and output ports: A/D, TIMER, and PWM. Refer to [Table 2-5](#) for the pin out of the UNI-3 connector.

**Table 2-5. UNI-3 Connector Description**

J1			
Pin #	Signal	Pin #	Signal
1	PWM0	2	NC
3	PWM1	4	NC
5	PWM2	6	NC
7	PWM3	8	NC
9	PWM4	10	NC
11	PWM5	12	GND
13	GND	14	+5.0V DC
15	+5.0V DC	16	NC
17	Analogue GND	18	Analogue GND
19	Analogue +15V DC	20	NC
21	Motor DC Bus Voltage Sense	22	Motor DC Bus Current Sense
23	Motor Phase A Current Sense	24	Motor Phase B Current Sense
25	Motor Phase C Current Sense	26	Motor Drive Temperature Sense
27	NC	28	NC
29	Motor Drive Brake Control	30	NC
31	PFC PWM	32	Input AC Current Sense <sup>1</sup>
33	AC Line Input Voltage <sup>1</sup>	34	Zero Cross A
35	Zero Cross B	36	Zero Cross C
37	NC	38	Back-EMF Phase A Sense
39	Back-EMF Phase B Sense	40	Back-EMF Phase C Sense

1. NOTE: Pins 32 & 33 are direct PFC control signals modified from standard UNI-3 specifications!

### 2.8.1 UNI-3 PFC PWM signal (Power Factor Correction)

The PFC PWM signal (Power Factor Correction) is used to additionally control the power stage. This signal is connected to the MC56F8013 controller's pin GPIO PB2 / MISO / T2 through the J9 jumper (PFC PWM Disable).

### 2.8.2 UNI-3 BRAKE

The brake signal is accessible via GPIO PB6 port (RxD), when jumper JP1 is set to position 1-2 and jumper J10 is set to position 2-3. When using the BRAKE signal, the JP3 jumper selection of Encoder INDEX / UNI-3 BEMFZCC signals must be disconnected to avoid hazardous states, as shown in [Figure 2-2](#).

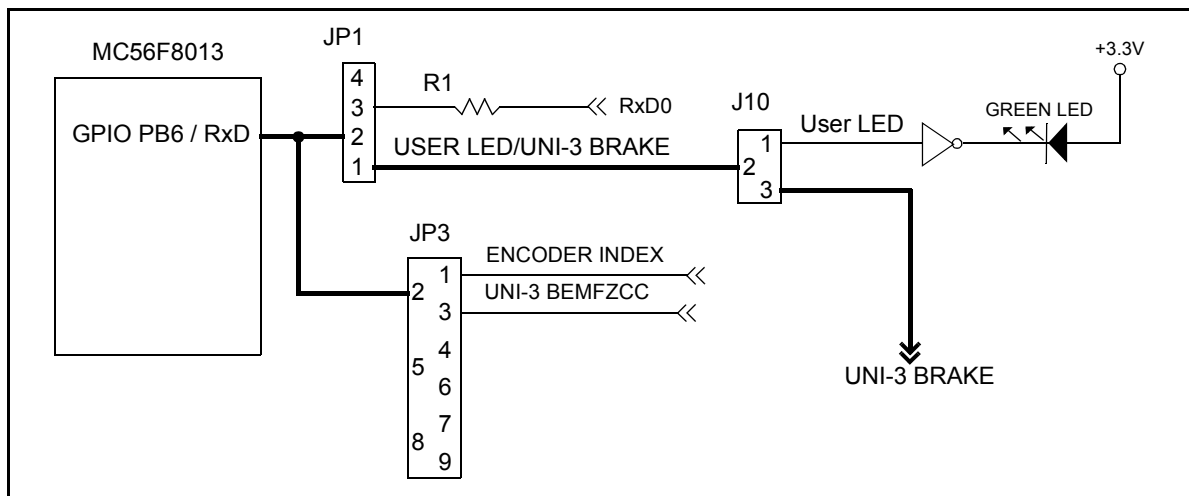
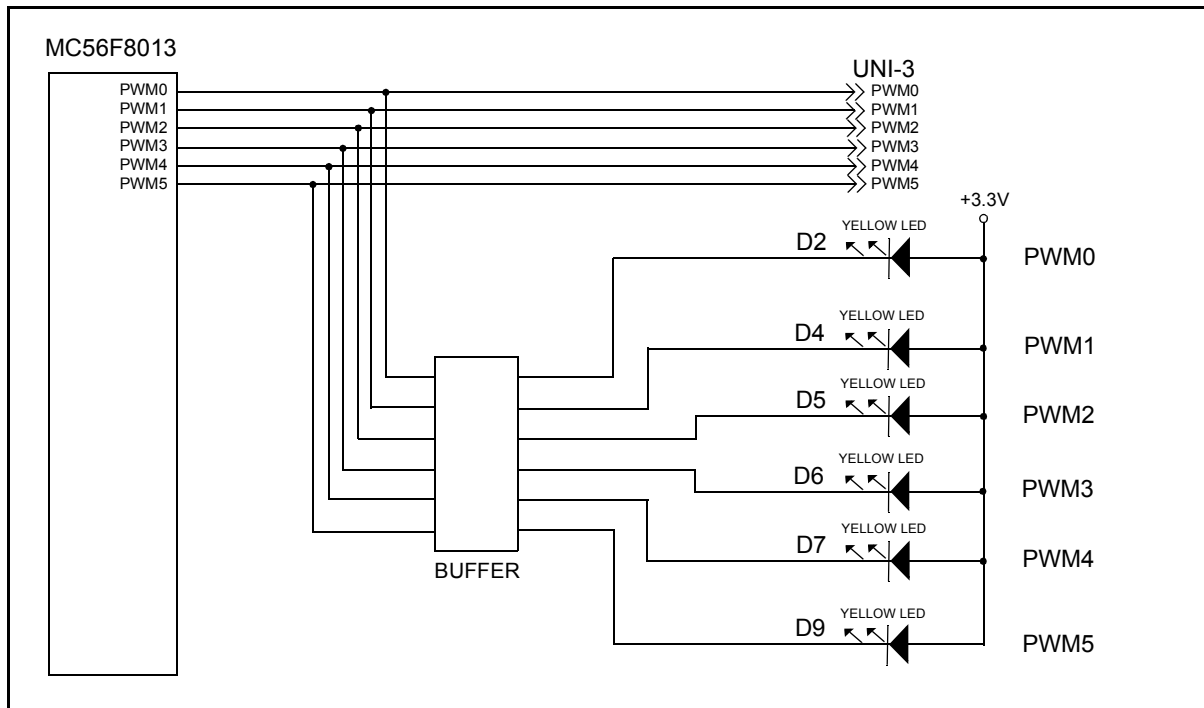

Figure 2-5. Schematic Diagram of the UNI-3 BRAKE connection

## 2.9 Motor Control PWM Signals and LEDs

The MC56F8013 controller has one dedicated PWM unit. This unit contains six PWM outputs and two Fault input lines, and a further two Fault input lines are shared by two PWM outputs. PWM output group lines are connected to the UNI-3 interface connector, and to a set of six PWM LEDs via inverting buffers. The buffers are used to isolate and drive the Digital Signal Controller's PWM outputs to the PWM LEDs. The PWM LEDs indicate the status of the PWM group signals, as shown in [Figure 2-6](#). One Fault LED is provided to easily monitor the fault states which depend on the voltage states of the UNI-3's *Motor DC Bus Voltage Sense* and *Motor DC Bus Current Sense* inputs.



**Figure 2-6. PWM Interface and LEDs**

## 2.10 Motor Protection Logic

The MC56F8013 Controller board contains a UNI-3 connector that interfaces with various motor drive boards. The Digital Signal Controller can sense error conditions generated by the motor power stage boards via signals on the UNI-3 connector. The motor driver board's DC Bus Voltage and DC Bus Current are sensed on the power stage board. The conditioned signals are transferred to the MC56F8013 Controller board via the UNI-3 connector. DC Bus Voltage and DC Bus Current analogue input signals are compared to a limit set by trim pots. If the input analogue signals are greater than the limit set by the trim pot, a Digital Signal Controller digital voltage compatible +3.3V DC fault signal is generated. The UNI-3 DC Bus Over-Voltage and DC Bus Over-Current signals are connected to the Digital Signal Controller's PWM fault input 0, as shown in [Figure 2-7](#).

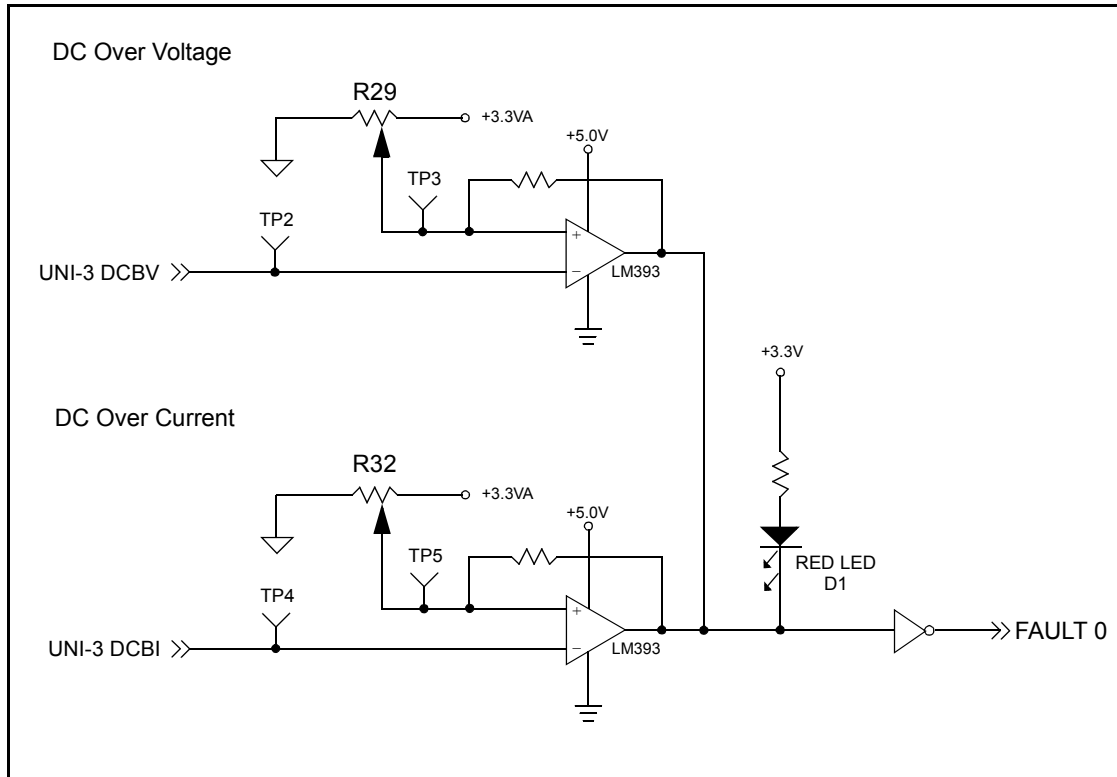
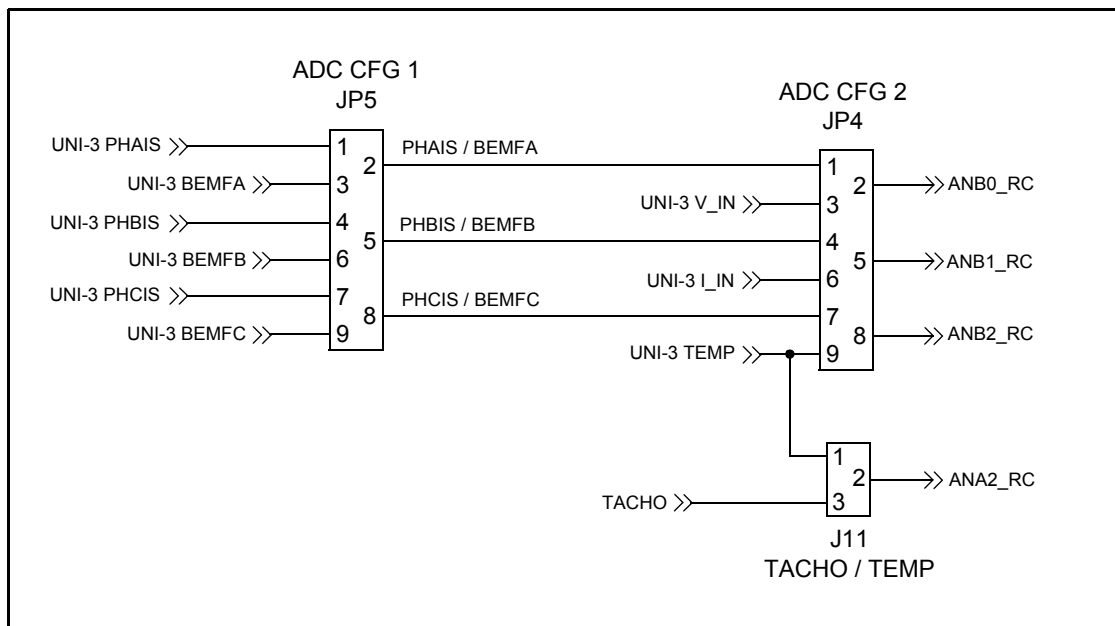

**Figure 2-7. FAULT Protection Circuit**

The DC-bus over-voltage and DC-bus over-current threshold levels can be adjusted by the trim-pots R29 and R32. Make sure there are no faults when exercising the on-chip PWM modules.

## 2.11 Back-EMF and Motor Phase Current Sensing

The UNI-3 connector supplies Back-EMF and Motor Phase Current signals from the three phases of a motor attached to the motor drive unit. The Back-EMF signals on the UNI-3 connectors are derived from a resistor divider network contained in the motor drive unit. These resistors scale down the attached motor's Back-EMF voltages to a 0 to +3.3V level. The Motor Phase Current signals are derived from current sense resistors. A jumper block JP5 (ADC CFG 1) provides the selection between each group of these signals, which will be monitored by the Digital Signal Controller A/D, as shown in [Table 2-6](#). Jumper block JP4 (ADC CFG 2) has to be set to positions 1-2, 4-5, and 7-8, see [Table 2-7](#). When jumper block JP4 is set to positions 2-3, 5-6, and 8-9, then the V\_IN, I\_IN, and TEMP inputs measurement are selected, see [Figure 2-8](#) for details. The temperature input TEMP can also be connected to ANA2\_RC input by setting jumper J11 to position 1-2.

**Figure 2-8. ADC input selection**
**Table 2-6. ADC input source selection (ADC CFG 1)**

Selector	Function	JP5
PHAIS / BEMFA	Phase A current measurement selected	1-2
	Phase A back EMF measurement selected	2-3
PHBIS / BEMFB	Phase B current measurement selected	4-5
	Phase B back EMF measurement selected	5-6
PHCIS / BEMFC	Phase C current measurement selected	7-8
	Phase C back EMF measurement selected	8-9

**Table 2-7. ADC input source selection (ADC CFG 2)**

Selector	Function	JP4	A/D Input
PHAIS/BEMFA / V_IN	PHAIS / BEMFA measurement selected	1-2	ANB0_RC
	V_IN measurement selected	2-3	
PHBIS/BEMFB / I_IN	PHBIS / BEMFB measurement selected	4-5	ANB1_RC
	I_IN measurement selected	5-6	
PHCIS/BEMFC / TEMP	PHCIS / BEMFC measurement selected	7-8	ANB2_RC
	TEMP measurement selected	8-9	

## 2.12 Quadrature Encoder/Hall-Effect Interfaces

The MC56F8013 Controller Board contains a Quadrature Encoder/Hall-Effect interface connected to the Digital Signal Controller's Quad Decoder input ports (Timer channel 0, 1 inputs) and Rx/D/GPIO PB6 input. The circuit is designed to accept +3.3V to +5.0V encoder or Hall-Effect sensor inputs. Input noise filtering is supplied on the input path for the Quadrature Encoder/Hall-Effect interface, along with additional noise reduction circuitry inside the Digital Signal Controller. **Figure 2-9** contains the encoder interface. **Table 2-8** shows the setting of jumper block JP3 to select between the Quadrature Encoder/Hall-Effect signals or Zero-Crossing signals.

## 2.13 Zero-Crossing Detection

An attached UNI-3 motor drive board contains logic that can send out pulses when the phase voltage of an attached 3-phase motor crosses zero. The motor drive board circuits generate a 0 to +3.3V DC pulse via voltage comparators. The resulting pulse signals are sent to a jumper block JP3 shared with the Encoder/Hall-Effect interface. The jumper block allows the selection of either Zero-Crossing signals or Quadrature Encoder/Hall-Effect signals, as shown in **Table 2-8**. When in operation, the Digital Signal Controller will only monitor one set of signals, Encoder/Hall-Effect or Zero-Crossing. **Figure 2-9** contains the Zero-Crossing and Encoder/Hall circuits.

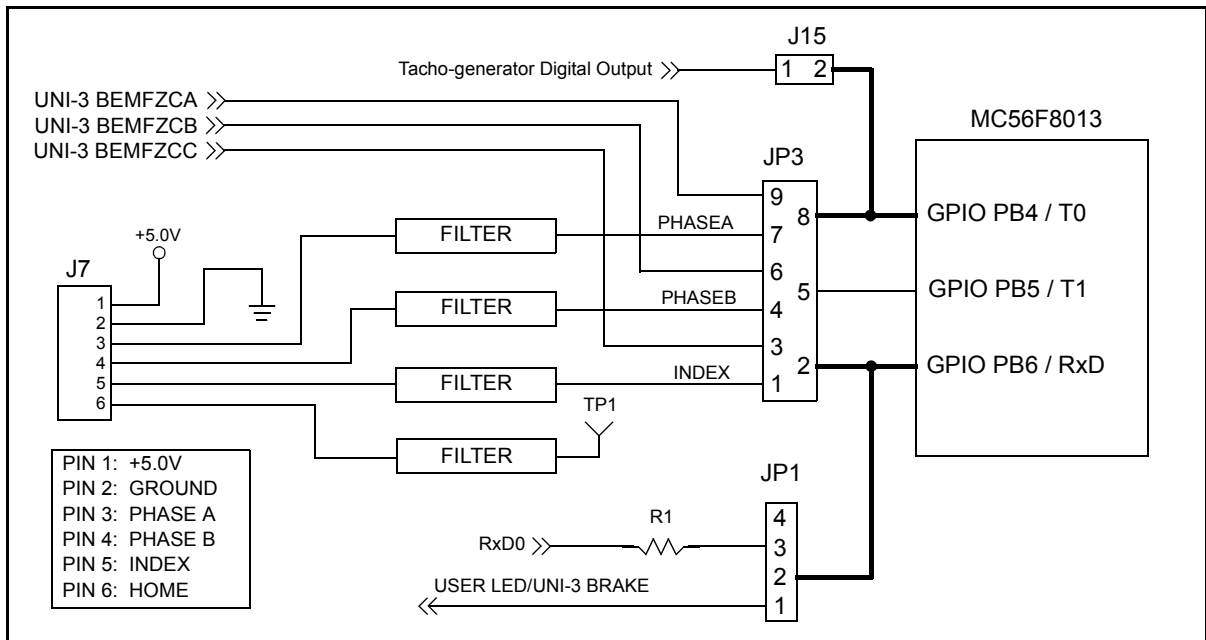

**Figure 2-9. Zero-Crossing/Encoder Interfaces**



Note that INDEX / BEMFZCC signal from the JP3 jumper is shared with the RxD signal from JP1 and PHASEA / BEMFZCA signal is shared with the Tacho-generator Digital Output from J15. To avoid hazardous states the JP1 and J15 should be disconnected.

**Table 2-8. Zero-Crossing/Encoder input source selection**

Selector	Function	JP3	
INDEX / BEMFZCC	Encoder INDEX input selected	1-2	GPIO PB6 / RxD
	Phase C back EMF zero-cross input selected	2-3	
PHASE B / BEMFZCB	Encoder PHASE B input selected	4-5	GPIO PB5 / T1
	Phase B back EMF zero-cross input selected	5-6	
PHASE A / BEMFZCA	Encoder PHASE A input selected	7-8	GPIO PB4 / T0
	Phase A back EMF zero-cross input selected	8-9	

## 2.14 Tacho-Generator Interface

The MC56F8013 Controller board contains a Tacho-generator interface for digital/analogue sensing with the external Tacho-Dynamo input. Input noise filtering is supplied on the input path then the signal passes through the voltage limiter to avoid damaging the following electrical circuitry. The signal then can be passed through jumper J14 to the ADC analogue input ANA2 for analogue sensing if the jumper is in position 1-2, or to the comparator with hysteresis for digital sensing if the jumper is in position 2-3, as shown in [Figure 2-10](#).

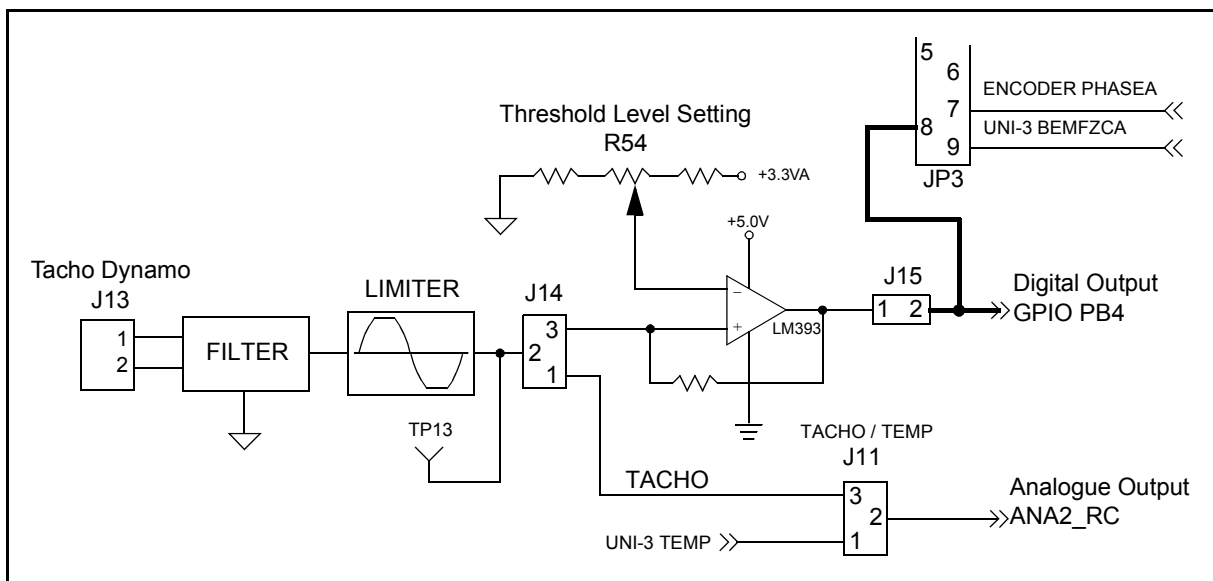

**Figure 2-10. Tacho-Generator Interface**

When digital sensing has been selected, the output of the comparator to GPIO port PB4 has to be enabled by closing jumper J15. **Table 2-9** shows the proper jumper setting when using the tacho-generator interface. The R54 trimpot serves to adjust the working point of the comparator. Note that Tacho-generator Digital Output signal from the J15 jumper is shared with the Encoder PHASEA / BEMFZCA signal from JP3. To avoid hazardous states, JP3 should be disconnected.

**Table 2-9. Tacho-Generator Operating Modes**

J14	J15	J11	Operating Mode	Output to
1-2	-	2-3	Analogue Sensing	ANA2_RC
2-3	closed	-	Digital Sensing	GPIO PB4

## 2.15 Serial EEPROM

The MC56F8013 Controller board contains a Serial EEPROM interface for 64 kbit memory (24LC64 or 24AA64) which can be optionally added (package pin number 3 - A2 must be additionally connected to GND). The memory is supplied by a 3.3V power supply and uses two communication lines to communicate with the MC56F8013 Controller, SCL connected to GPIO PB0 (GPIO PB0/SCLK/SCL) through jumper J20, and SDA connected to GPIO PB1 (GPIO PB1/ $\overline{SS}$ /SDA) through jumper J21, as shown in **Figure 2-11**.

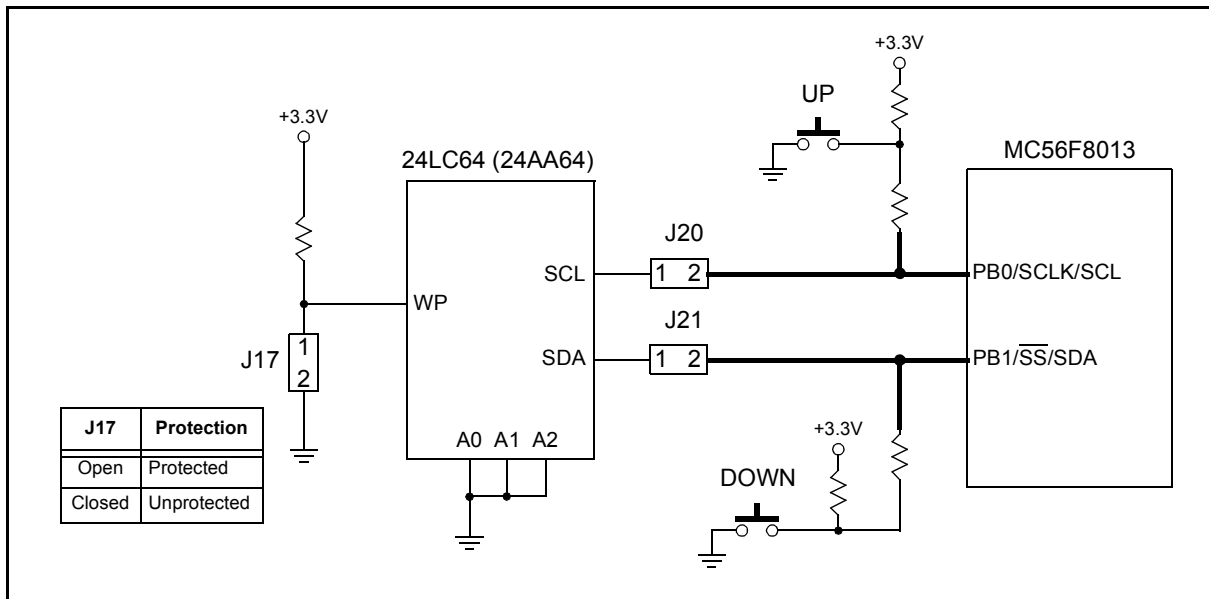

**Figure 2-11. Serial EEPROM Interface**

The memory can be write protected or unprotected by using the J17 jumper. If J17 is open, the memory is write protected, WRITE operations are inhibited, but read operations are not affected. When jumper J17 is closed, WRITE operations are allowed. Note that the Serial EEPROM memory interface signals are shared with signals from the UP and DOWN buttons, which can not be used while using Serial memory. The SCL signal is also shared with the SPI (Serial Peripheral Interface), and so SPI communication can not be used while using Serial memory.

## 2.16 Peripheral Expansion Connectors

The MC56F8013 Controller Board contains a group of Peripheral Expansion Connectors used to gain access to the resources of the MC56F8013. The following signal groups have Expansion Connectors:

- Encoder
- Tacho-Dynamo Input
- GPIO B Port
- A/D Input Port
- PWM Port
- SPI Port

### 2.16.1 Encoder Exp. Connector

The Quadrature Encoder interface port is attached to this expansion connector. Refer to [Table 2-10](#) for connection information.

**Table 2-10. Encoder Connector Description**

J7	
Pin #	Signal
1	+5V
2	GND
3	PHASE A / T0
4	PHASE B / T1
5	INDEX / RxD
6	HOME

## 2.16.2 Tacho-Dynamo Exp. Connector

The Tacho-Generator interface includes the Tacho-Dynamo input expansion connector, as shown in [Table 2-11](#).

**Table 2-11. Tacho-Dynamo Connector Description**

J13	
Pin #	Signal
1	Tacho dynamo Input 1
2	Tacho dynamo Input 2

## 2.16.3 GPIO B Port Expansion Connector

The GPIO B port attached to this connector is an MPIO port. The General Purpose I/O port B pins are shared with a Serial Peripheral Interface, Serial Communications Interface, Timer I/O, I2C, and PWM FAULT 3 input. Refer to [Table 2-12](#) for connection information.

**Table 2-12. GPIO B Port Connector Description**

J2			
Pin #	Signal	Pin #	Signal
1	PB0 / SCLK / SCL	2	PB1 / $\overline{SS\_B}$ / SDA
3	PB2 / MISO / T2	4	PB3 / MOSI / T3
5	PB4 / T0 / CLK0	6	PB5 / T1 / FAULT3
7	PB6 / RxD / SDA / CLKIN	8	BP7 / TxD / SCL
9	+3.3V	10	GND

## 2.16.4 A/D Port Expansion Connector

The 6-channel Analogue to Digital conversion port is attached to this connector. Refer to [Table 2-13](#) for connection information. There is an RC network on each of the Analogue Port input signals; reference [Figure 2-12](#).

**Table 2-13. A/D Port Connector Description**

J5			
Pin #	Signal	Pin #	Signal
1	+3.3V	2	GNDA
3	UNI-3 DCBV	4	UNI-3 DCBI
5	ANA2_RC	6	ANB0_RC
7	ANB1_RC	8	ANB2_RC
9	+3.3V	10	GNDA

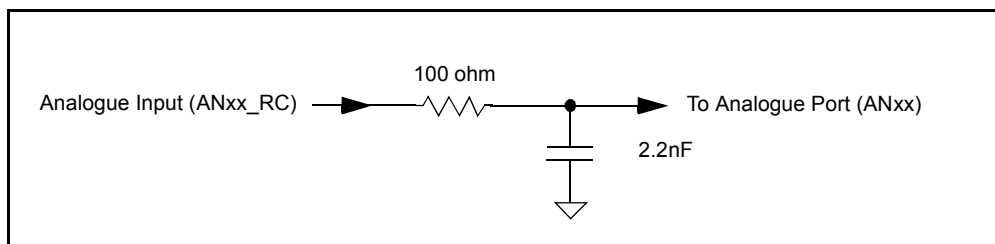

**Figure 2-12. Typical Analogue Input RC Filter**

## 2.16.5 PWM Port Expansion Connector

The PWM port is attached to this connector. Refer to [Table 2-14](#) for connection information.

**Table 2-14. PWM Port Connector Description**

J3			
Pin #	Signal	Pin #	Signal
1	PWM0	2	PWM1
3	PWM2	4	PWM3
5	PWM4	6	PWM5
7	GND	8	FAULT0
9	GND	10	+3.3V

### 2.16.6 SPI Port Expansion Connector

The Serial Peripheral Interface is an MPIO port attached to the GPIO B expansion connector. The connector pins can be configured as a Serial Peripheral Interface or as a General Purpose I/O port. Refer to [Table 2-15](#) for connection information.

**Table 2-15. SPI Connector Description**

J19	
Pin #	Signal
1	GND
2	SCLK
3	MISO
4	MOSI

### 2.17 Test Points

The MC56F8013 Controller Board has 13 test pins. The four test pins are located near the corners of the board and provides a GND signal (digital ground) for easy oscilloscope attachment.

# **Appendix A**

## **MC56F8013 Controller Board**

### **Schematics**

Place filters as close to the DSP chip as possible

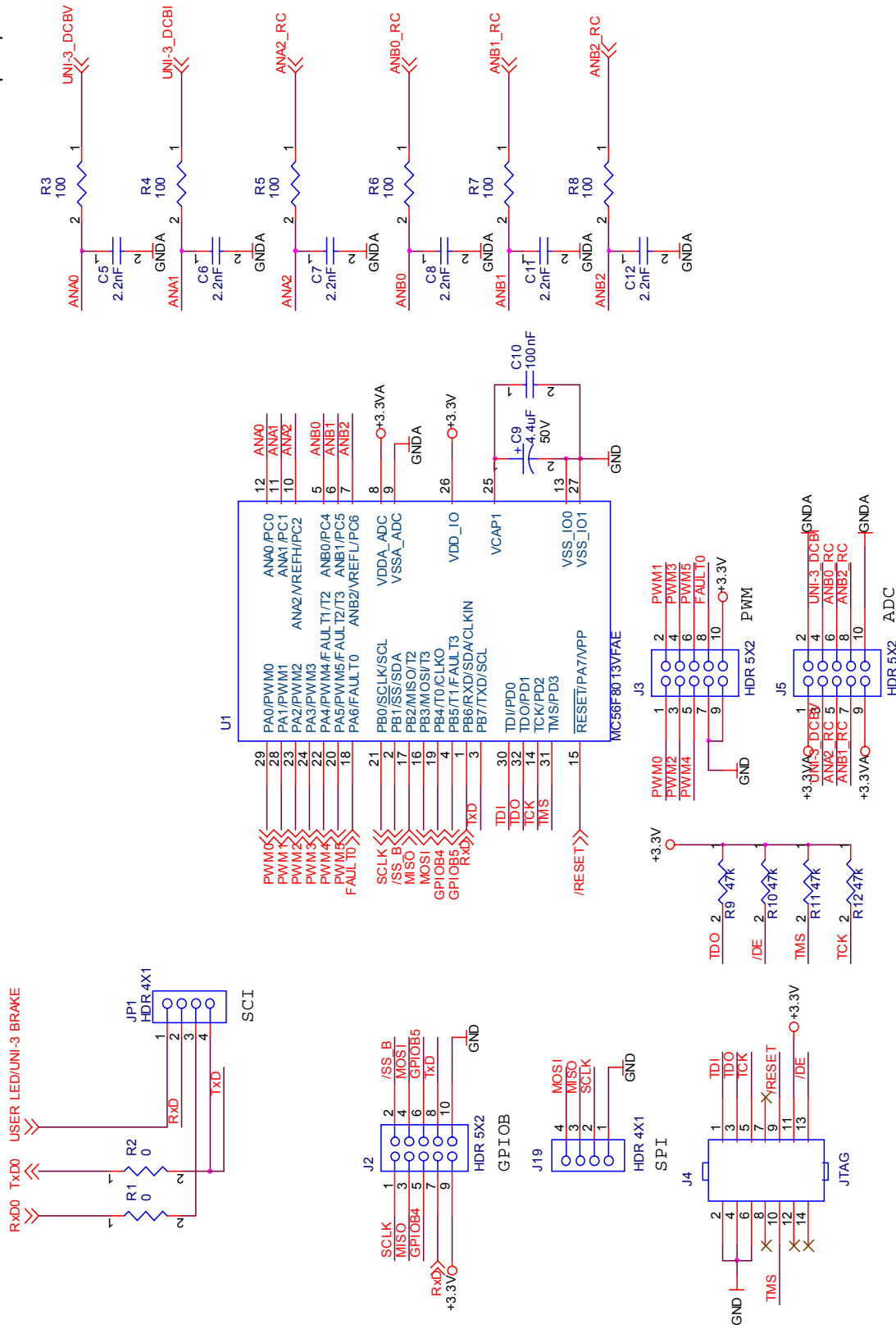
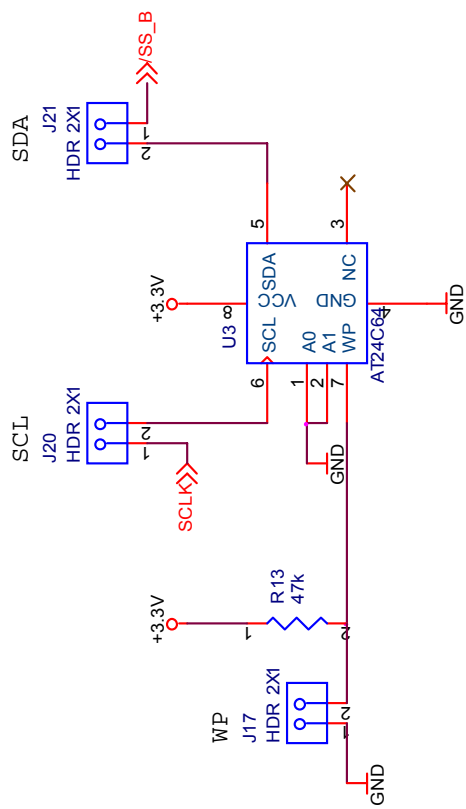
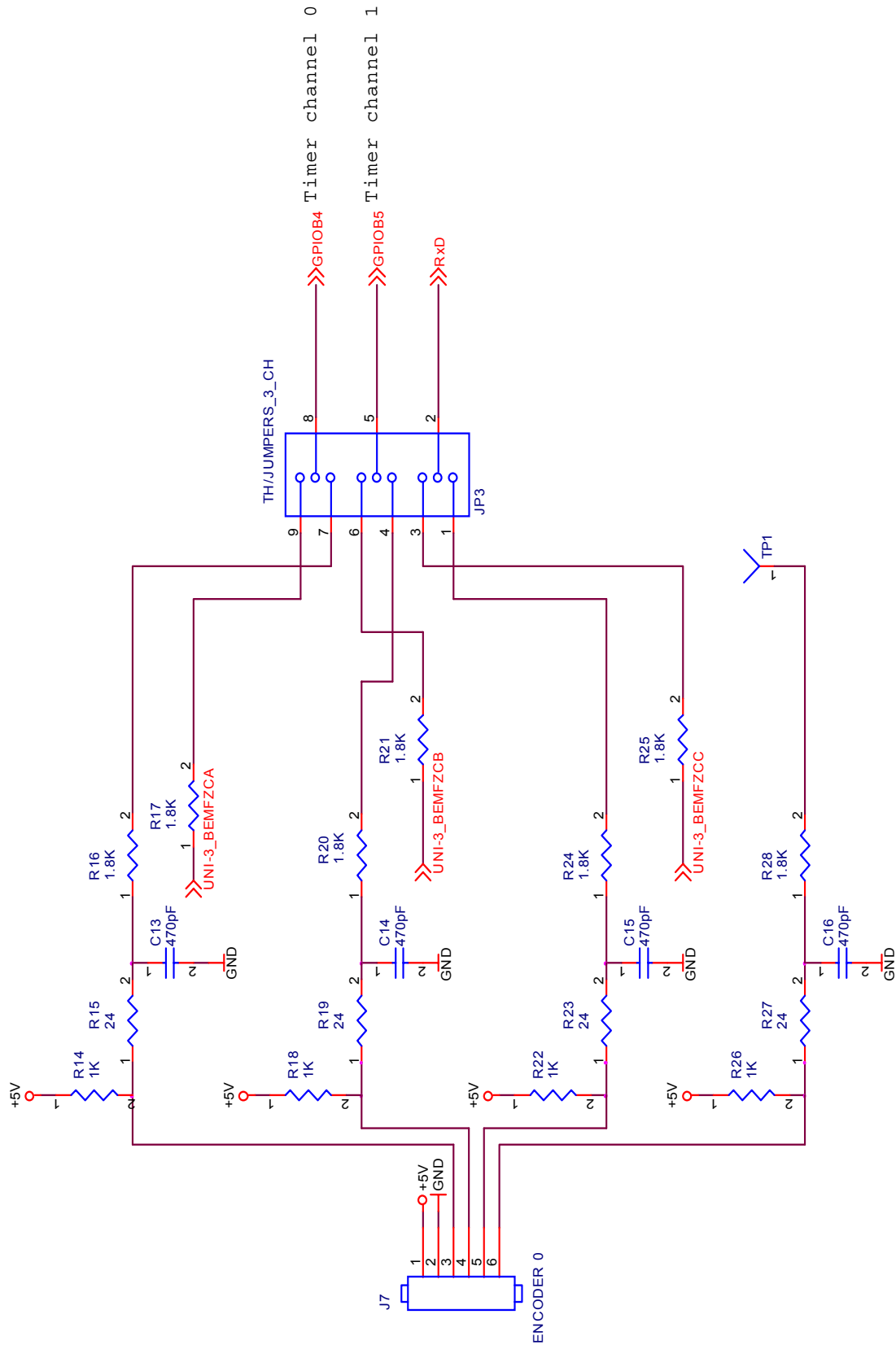

Figure A-1. MC56F8013 and Headers





**Figure A-2. Serial EEPROM**



**Figure A-3. Quadrature Encoder or Hall Sensors / Zero Crossing**

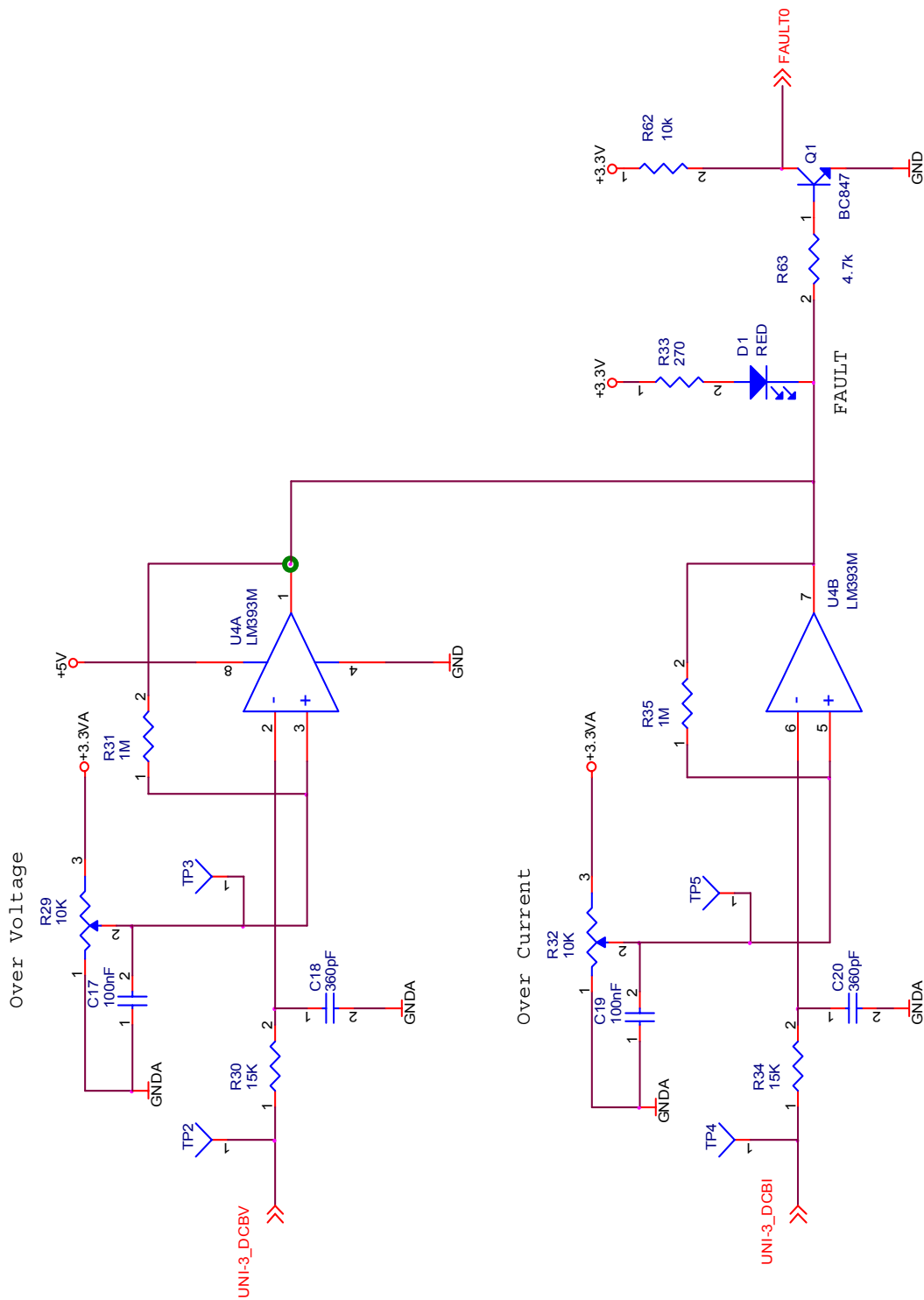

Figure A-4. Fault protection

ANALOG CHANNELS CONFIGURATION

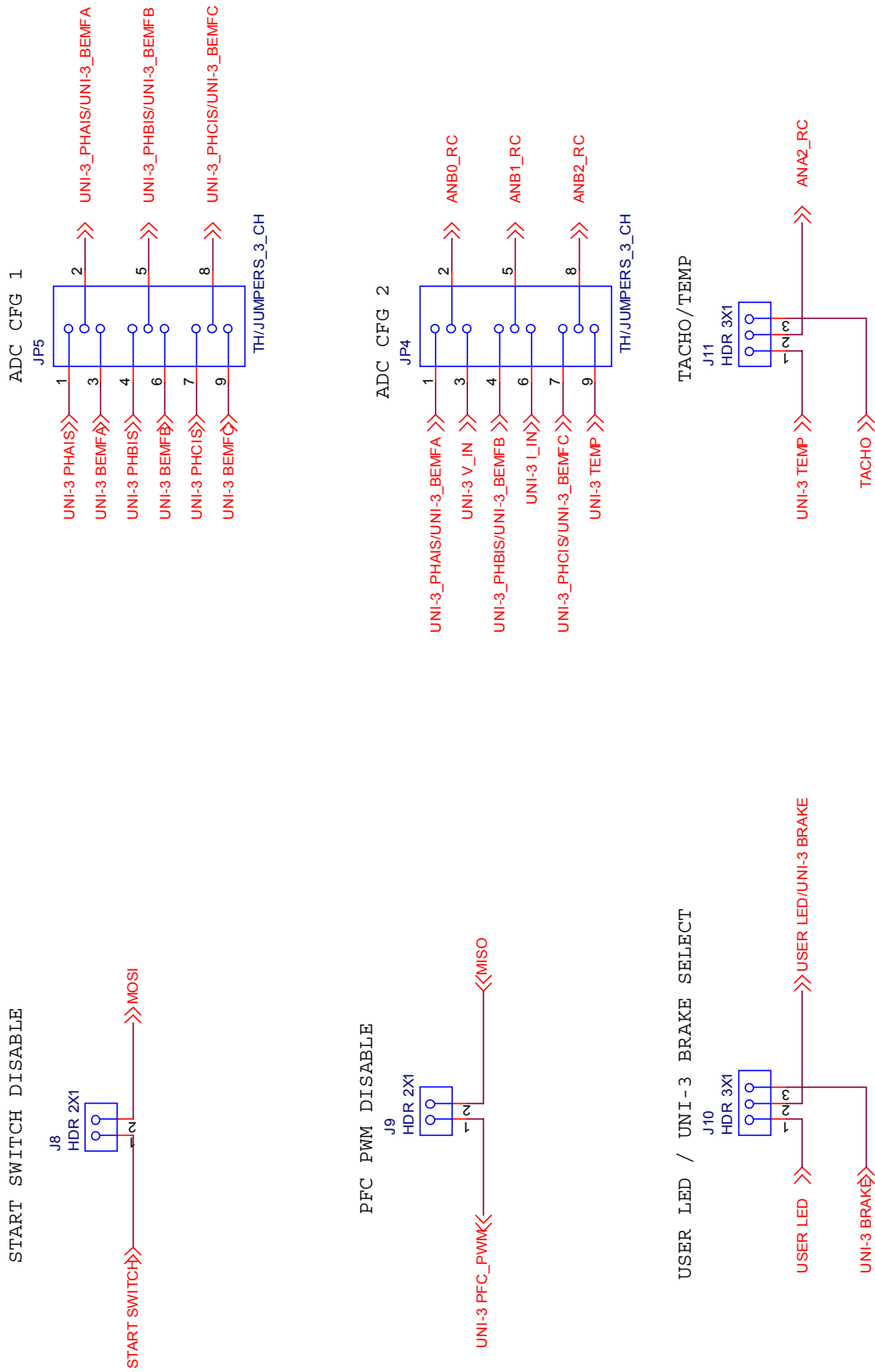

Figure A-5. Jumpers

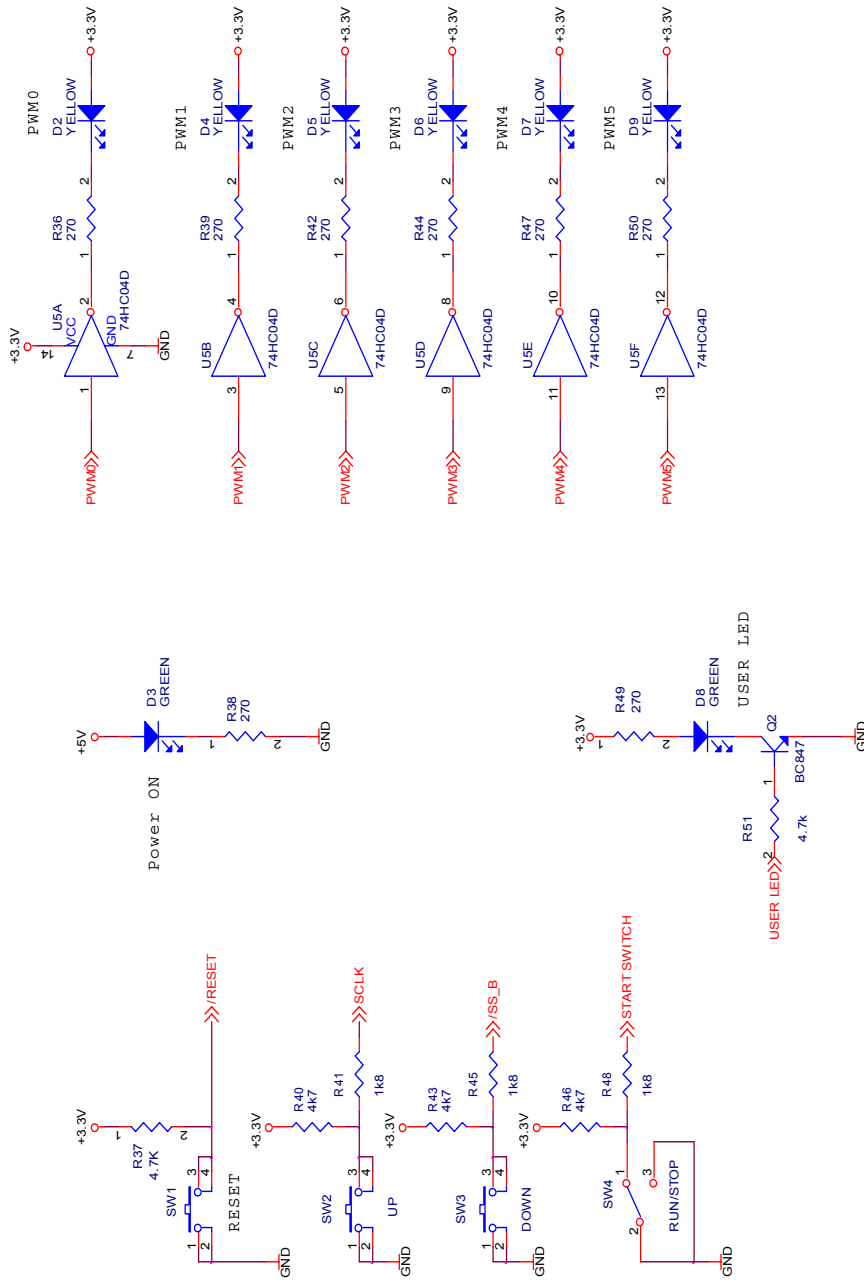

Figure A-6. LEDs and buttons

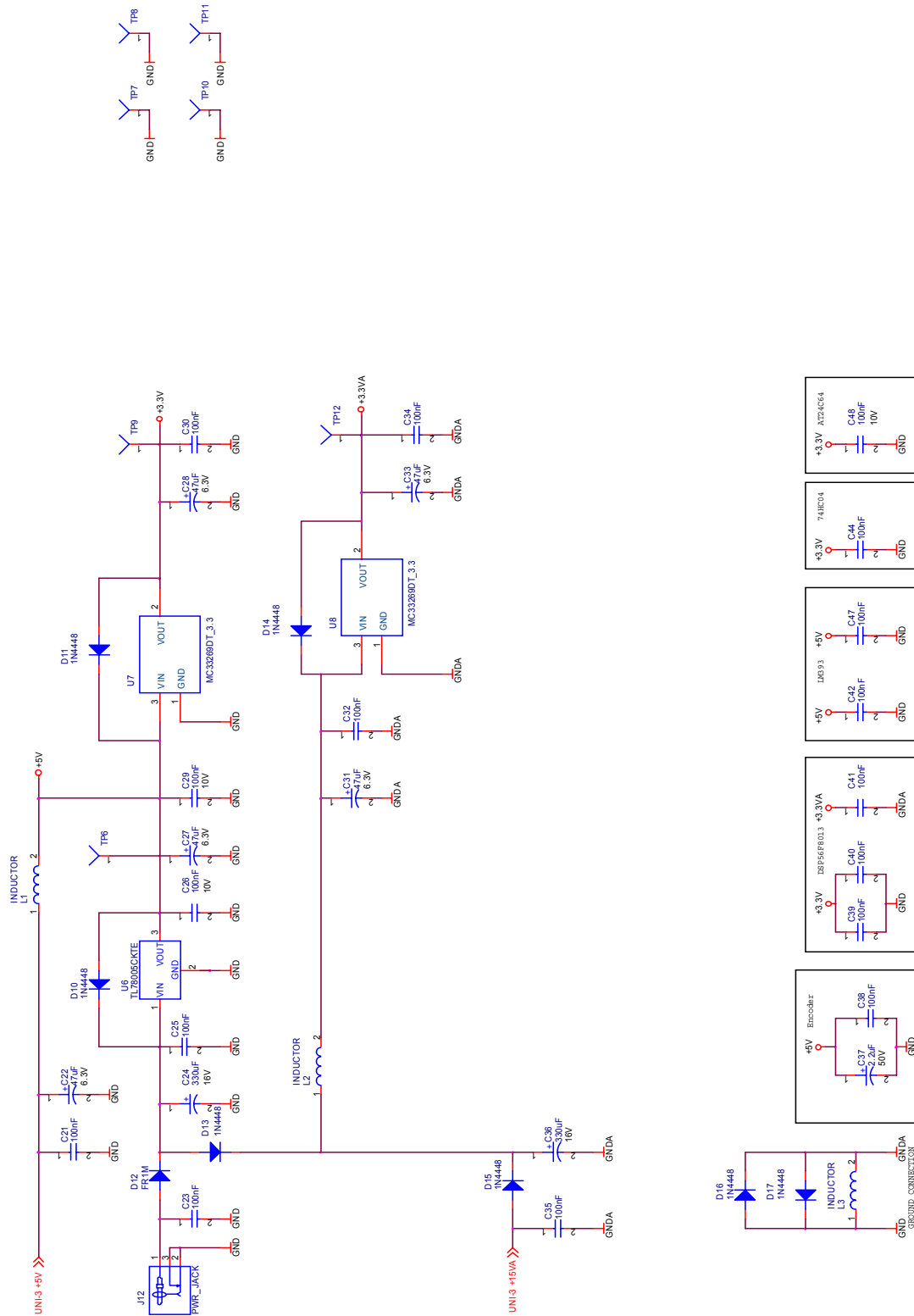

Figure A-7. Power Supply

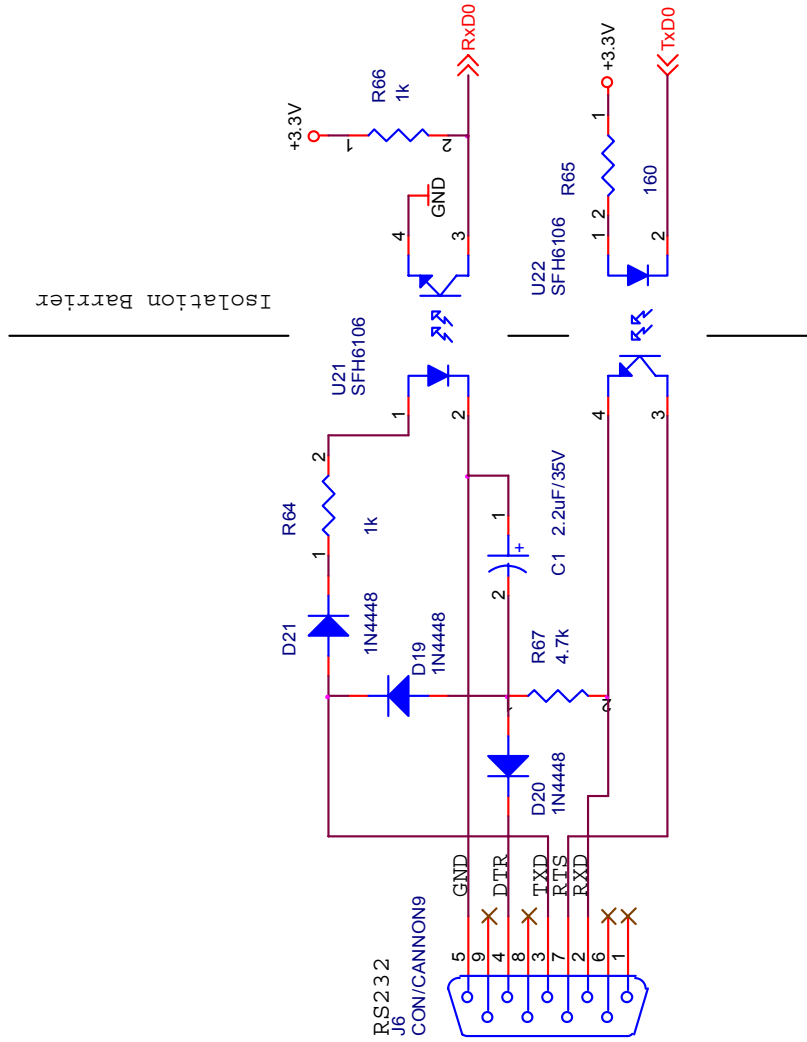
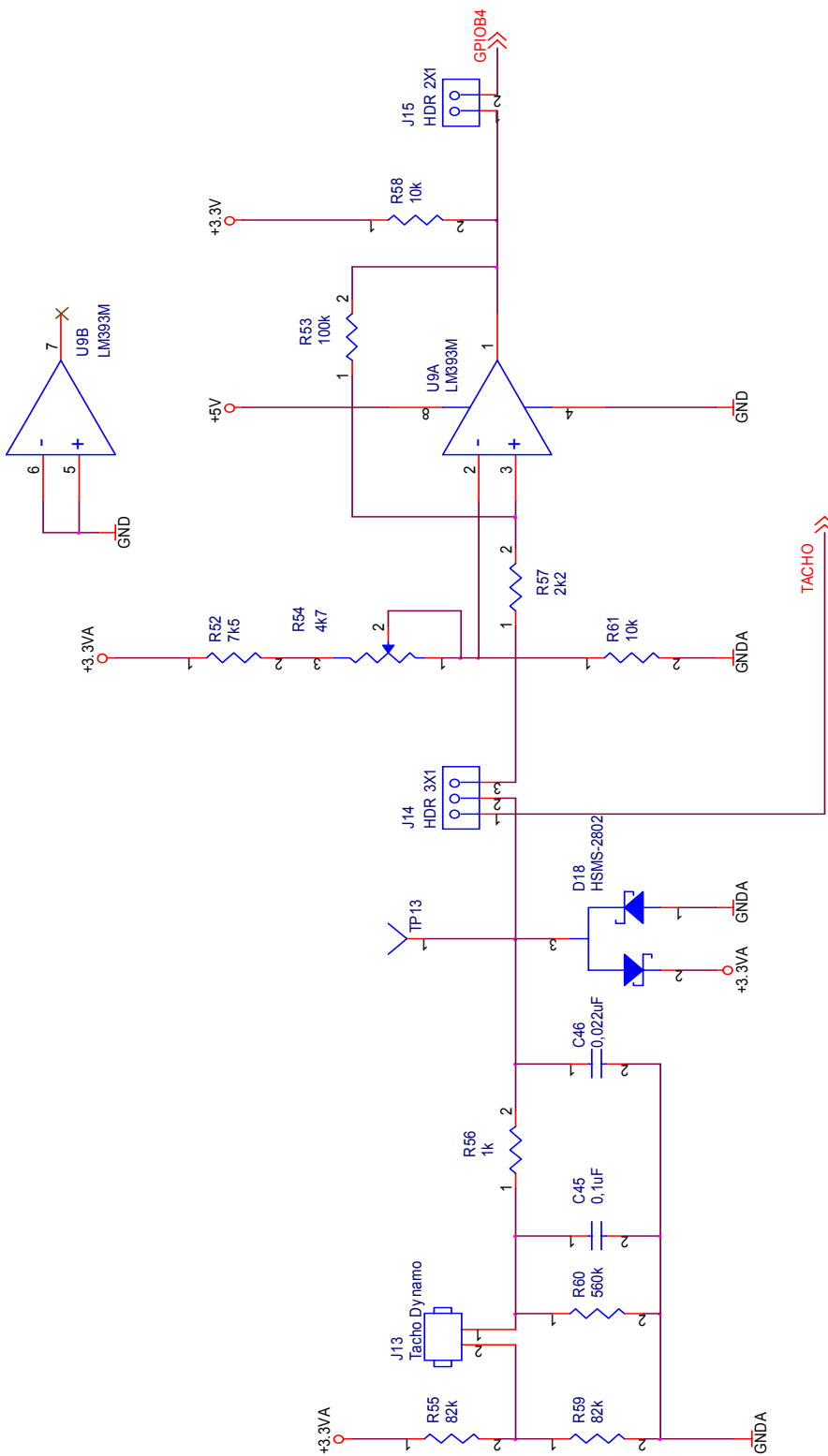

Figure A-8. RS232



**Figure A-9. Tachogenerator**



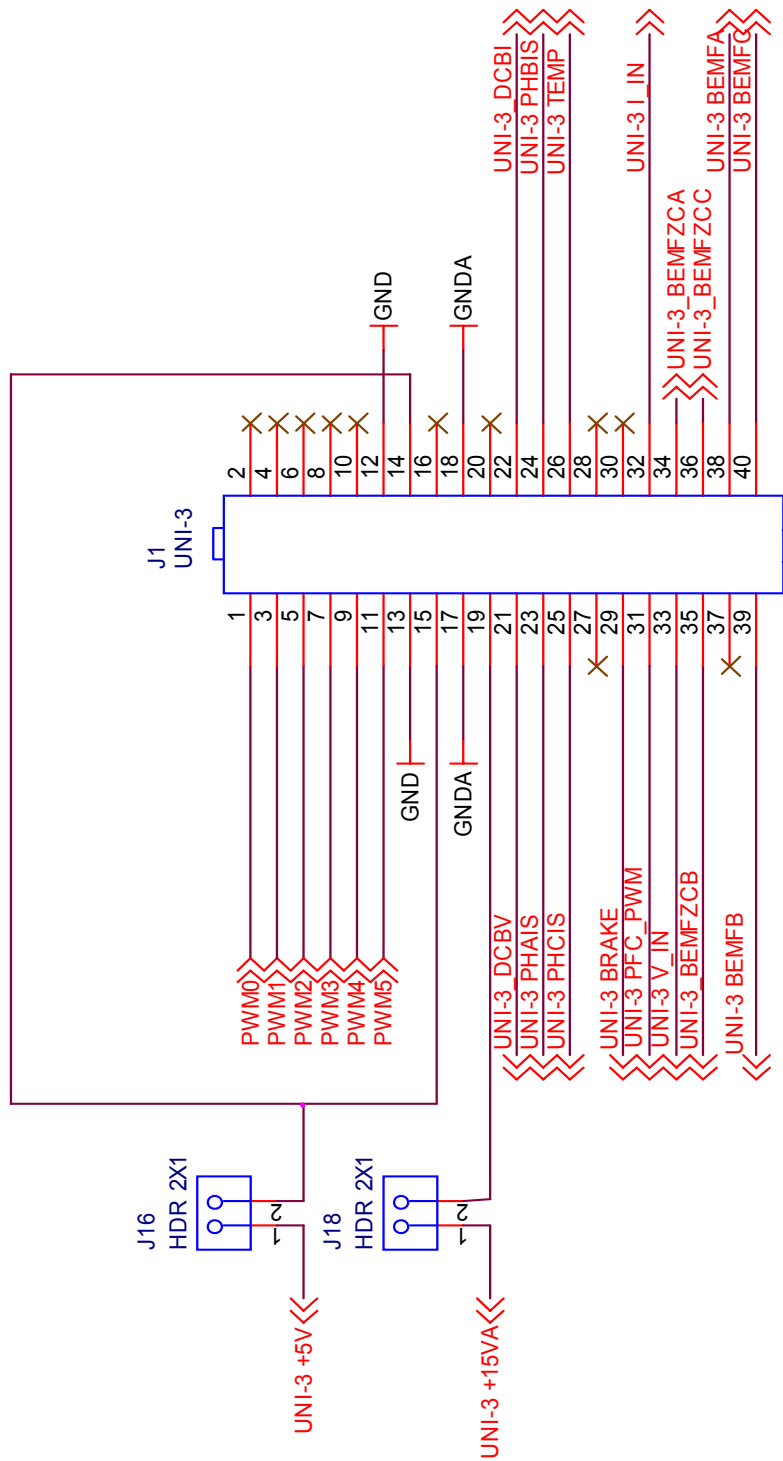

Figure A-10. UNI-3 connector



# **Appendix B**

## **MC56F8013 Controller Board**

### **PCB**

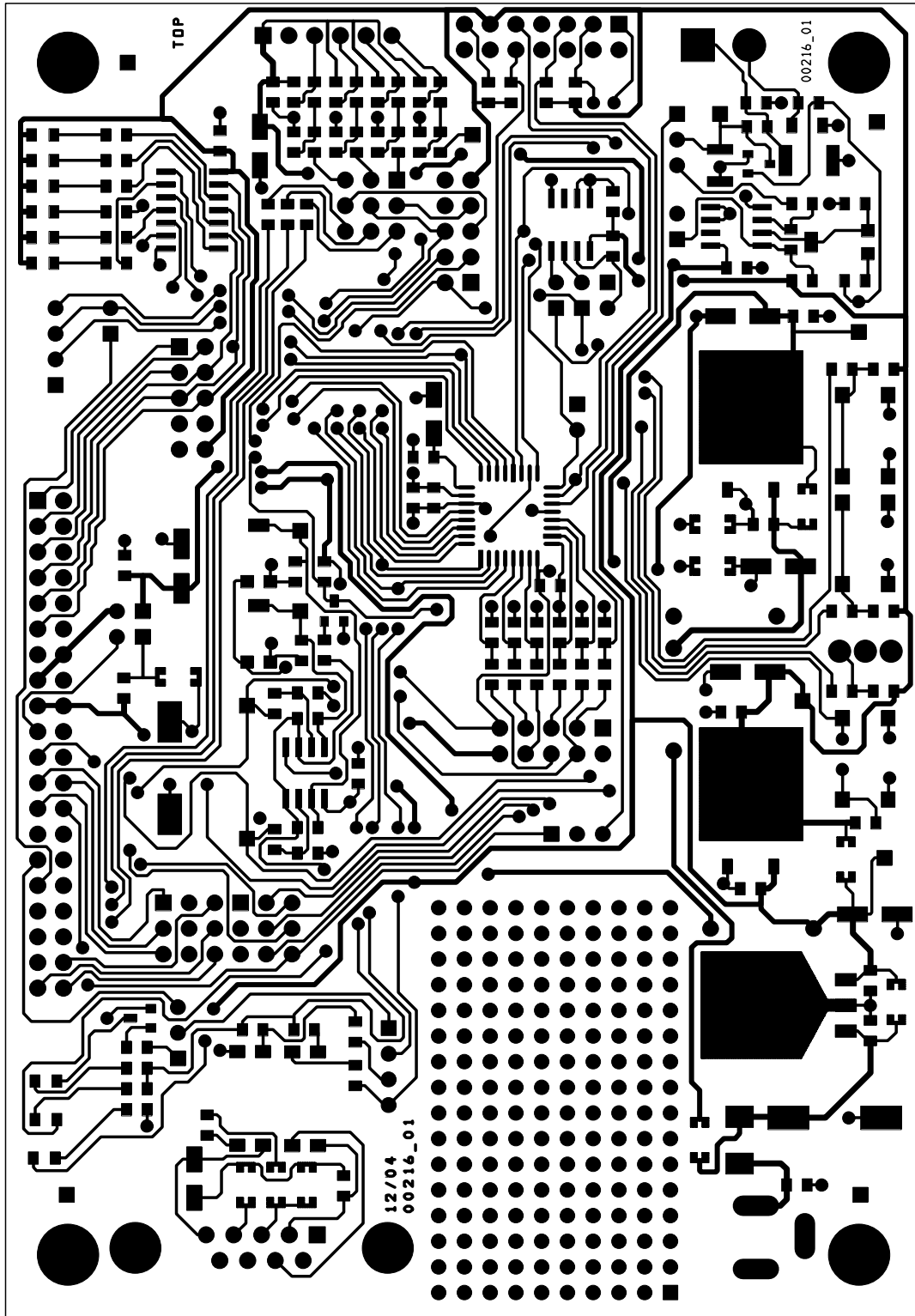

Figure B-1. TOP copper layer

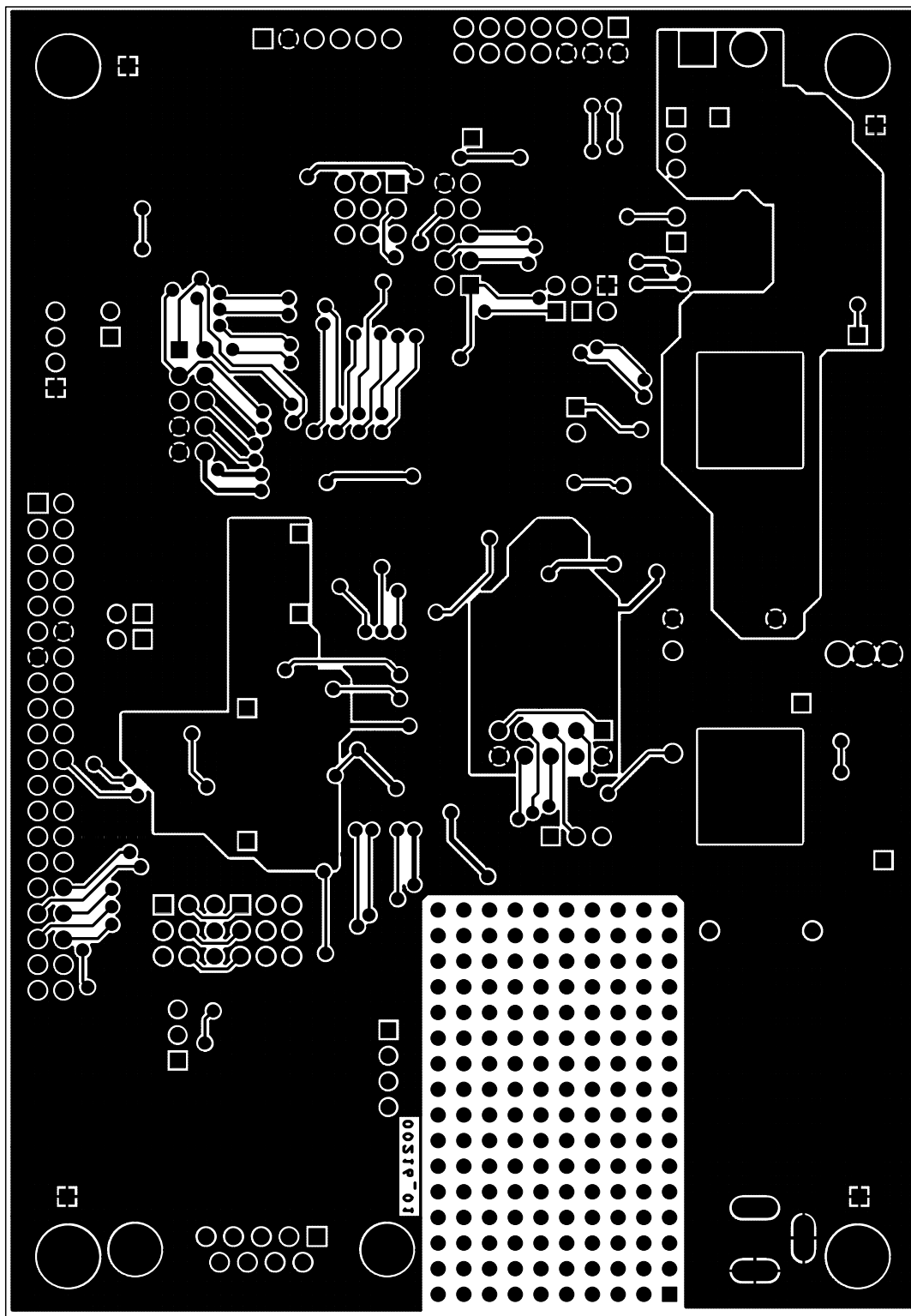
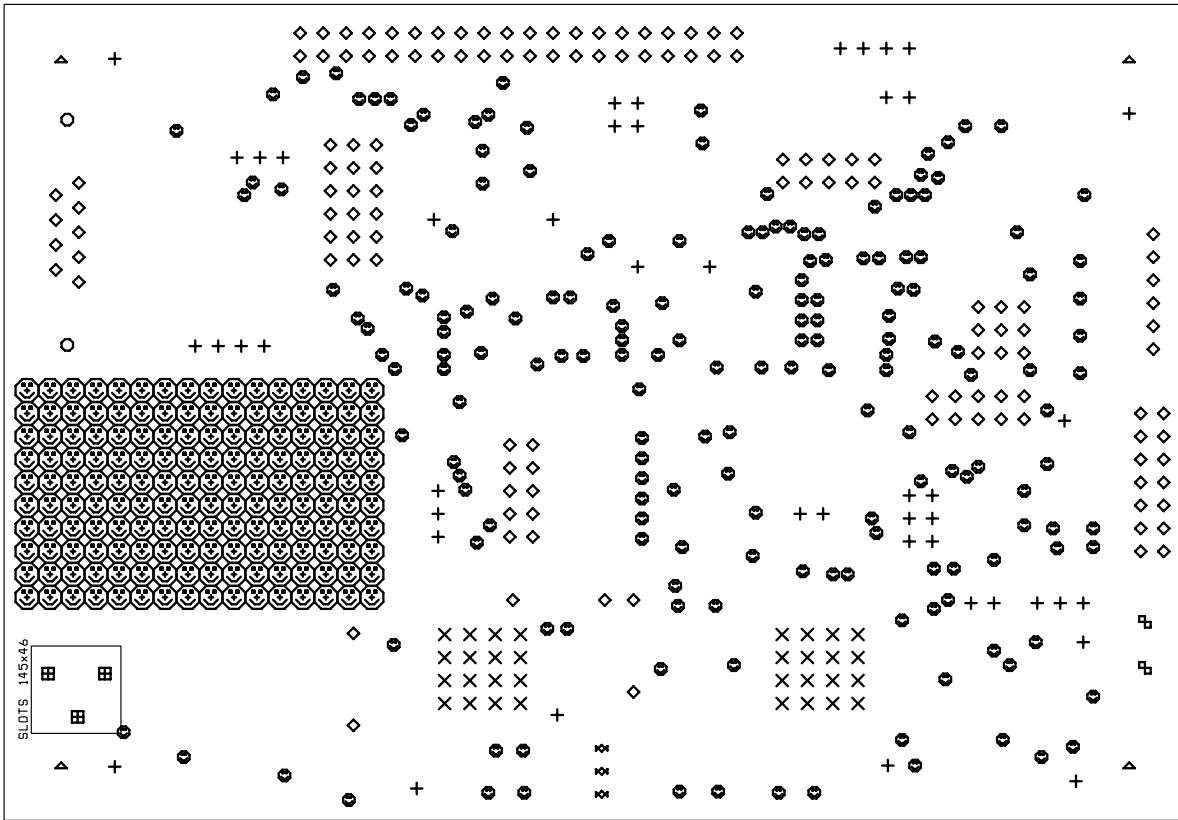

Figure B-2. BOTTOM copper layer



DRILL CHART				
SYM	DIAM	TOL	QTY	NOTE
x	0.024		32	
⊙	0.028		180	
⊕	0.034		160	
+	0.039		46	
◇	0.040		132	
⊞	0.046		3	
⊞	0.050		2	
*	0.064		3	
○	0.120		2	
△	0.140		4	
TOTAL			564	

Figure B-3. Drill copper map

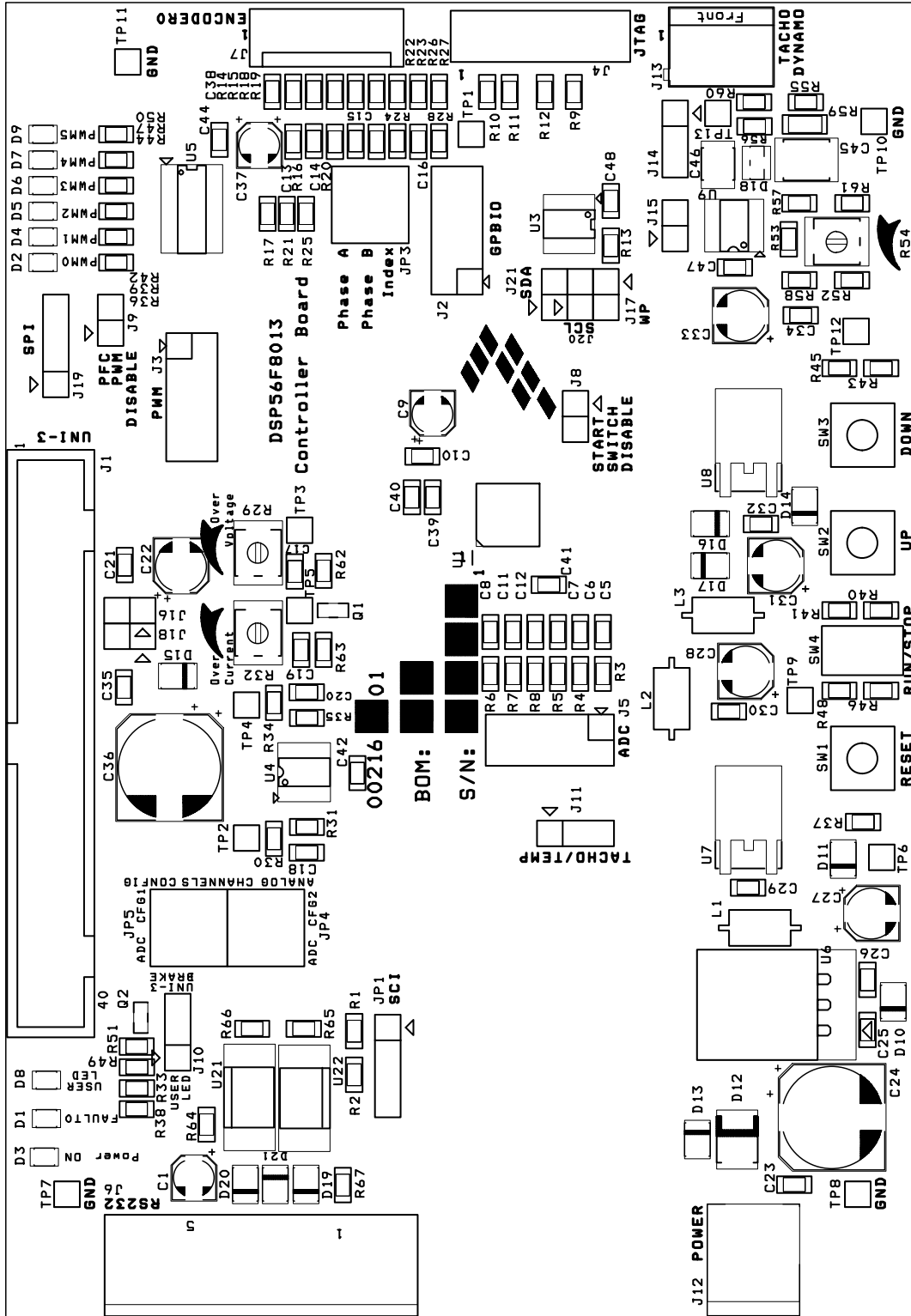

Figure B-4. TOP silk screen layer



Figure B-5. TOP Board view



# Appendix C

## MC56F8013 Controller Board

### Bill of Materials

Item	Qty	Description	Reference Designators	Part #/ Value
<b>Capacitors</b>				
1	1	SMD, Polarized, Aluminim, size B, 35V	C1	2.2uF/35V
2	6	SMD, Ceramic, size 0805	C5,C6,C7,C8,C11,C12	2.2nF
3	1	SMD, Polarized, Aluminim, size B, 50 V	C9	4.4uF/50V
4	20	SMD, Ceramic, size 0805	C10,C17,C19,C21,C23,C25,C26,C29,C30,C32,C34,C35,C38,C39,C40,C41,C42,C44,C47,C48	100nF
5	4	SMD, Ceramic, size 0805	C13,C14,C15,C16	470pF
6	2	SMD, Ceramic, size 0805	C18,C20	360pF
7	4	SMD, Polarized, Aluminim, size C, 6.3V	C22,C27,C28,C33	47uF/6.3V
8	2	SMD, Polarized, Aluminim, size G, 16V	C24,C36	330uF/16V
9	1	SMD, Polarized, Aluminim, size B, 50V	C37	2.2uF/50V
10	1	SMD, Ceramic, size 1812	C45	0,1uF
11	1	SMD, Ceramic, size 1210	C46	0,022uF
12	1	SMD, Polarized, Aluminim, size C, 16V	C31	22uF/16V
<b>Diodes / LED</b>				
13	1	SMD, size 0805	D1	RED
14	6	SMD, size 0805	D2,D4,D5,D6,D7,D9	YELLOW

Item	Qty	Description	Reference Designators	Part #/ Value
15	2	SMD, size 0805	D3,D8	GREEN
16	10	SMD, minimelf	D10,D11,D13,D14,D15,D16, D17,D19,D20,D21	1N4448
17	1	SMD, MELF	D12	SM4007
18	1	SMD, SOT-23	D18	HSMS-2802
<b>Connectors / Jumpers</b>				
19	2	Header 4X1, 2.54mm	JP1,J19	HDR 4X1
20	3	Header 3X1, 2.54mm	JP3,JP4,JP5	TH/JUMPERS_3_CH
21	1	MLW40G	J1	UNI-3
22	3	Header 5X2, 2.54mm	J2,J3,J5	HDR 5X2
23	1	Header 7X2, 2.54mm	J4	JTAG
24	1	CAN9 Z 90	J6	CON/CANNON9
25	1	PSH02 - 06P	J7	ENCODER 0
26	8	Header 2X1, 2.54mm	J8,J9,J15,J16,J17,J18,J20,J21	HDR 2X1
27	3	Header 3X1, 2.54mm	J10,J11,J14	HDR 3X1
28	1	NAZ 2.1 VP	J12	PWR_JACK
29	1	ARK500/2	J13	Tacho Dynamo
30	13	Header 1X1, 2.54mm	TP1,TP2,TP3,TP4,TP5, TP6,TP7,TP8,TP9,TP10, TP11,TP12,TP13	TEST POINT
<b>Inductors</b>				
31	3	Multicomp MCAB 035060-33	L1,L2,L3	INDUCTOR
<b>Transistors</b>				
32	2	SMD, SOT23	Q1,Q2	BC847
<b>Resistors / Potentiometers/ Trimmers</b>				
33	2	SMD, size 0805	R1,R2	0
34	6	SMD, size 0805	R3,R4,R5,R6,R7,R8	100
35	5	SMD, size 0805	R9,R10,R11,R12,R13	47k
36	7	SMD, size 0805	R14,R18,R22,R26,R56	1k
37	4	SMD, size 0805	R15,R19,R23,R27	24
38	7	SMD, size 0805	R16,R17,R20,R21,R24, R25,R28	1.8K

Item	Qty	Description	Reference Designators	Part #/ Value
39	3	SMD, size 0805	R58,R61,R62	10k
40	2	Trimmer	R29,R32	10k
41	2	SMD, size 0805	R30,R34	15K
42	2	SMD, size 0805	R31,R35	1M
43	9	SMD, size 0805	R33,R36,R38,R39,R42, R44,R47,R49,R50	270
44	7	SMD, size 0805	R40,R43,R46,R37,R51, R66,R67	4k7
45	1	Trimmer	R54	4k7
46	3	SMD, size 0805	R41,R45,R48	1k8
47	1	SMD, size 0805	R52	7k5
48	1	SMD, size 0805	R53	100k
49	2	SMD, size 0805	R55,R59	82k
50	1	SMD, size 0805	R57	2k2
51	1	SMD, size 0805	R60	560k
52	1	SMD, size 0805	R65	360
53	1	SMD, size 0805	R63	62k
54	1	SMD, size 0805	R64	560
<b>Switches / Pushbuttons</b>				
55	1	KSC221J	SW1	RESET
56	1	KSC221J	SW2	UP
57	1	KSC221J	SW3	DOWN
58	1	EZK - MS244LC	SW4	RUN/STOP
<b>Integrated Circuits</b>				
59	1	Freescale Semiconductor Hybrid Controller	U1	MC56F8013VFAE
60	0	no pop	U3	AT24LC64 / 24AA64
61	2	LM393M, SMD, SOIC8	U4,U9	LM393M
62	1	74HC04D, SMD, SOIC14	U5	74HC04D
63	1	MC7805CD2T,SMD, D2PAK	U6	MC7805CD2T
64	2	MC33269DT_3.3, SMD, DPAK	U7,U8	MC33269DT_3.3
65	2	SFH6106, Optocoupler, SMD	U21,U22	SFH6106





## **How to Reach Us:**

### **USA/Europe/Locations not listed:**

Freescale Semiconductor Literature Distribution  
P.O. Box 5405, Denver, Colorado 80217  
1-800-521-6274 or 480-768-2130

### **Japan:**

Freescale Semiconductor Japan Ltd.  
SPS, Technical Information Center  
3-20-1, Minami-Azabu  
Minato-ku  
Tokyo 106-8573, Japan  
81-3-3440-3569

### **Asia/Pacific:**

Freescale Semiconductor H.K. Ltd.  
2 Dai King Street  
Tai Po Industrial Estate  
Tai Po, N.T. Hong Kong  
852-26668334

### **Learn More:**

For more information about Freescale Semiconductor products, please visit <http://www.freescale.com>

Information in this document is provided solely to enable system and software implementers to use Freescale Semiconductor products. There are no express or implied copyright licenses granted hereunder to design or fabricate any integrated circuits or integrated circuits based on the information in this document.

Freescale Semiconductor reserves the right to make changes without further notice to any products herein. Freescale Semiconductor makes no warranty, representation or guarantee regarding the suitability of its products for any particular purpose, nor does Freescale Semiconductor assume any liability arising out of the application or use of any product or circuit, and specifically disclaims any and all liability, including without limitation consequential or incidental damages. "Typical" parameters which may be provided in Freescale Semiconductor data sheets and/or specifications can and do vary in different applications and actual performance may vary over time. All operating parameters, including "Typicals" must be validated for each customer application by customer's technical experts. Freescale Semiconductor does not convey any license under its patent rights nor the rights of others. Freescale Semiconductor products are not designed, intended, or authorized for use as components in systems intended for surgical implant into the body, or other applications intended to support or sustain life, or for any other application in which the failure of the Freescale Semiconductor product could create a situation where personal injury or death may occur. Should Buyer purchase or use Freescale Semiconductor products for any such unintended or unauthorized application, Buyer shall indemnify and hold Freescale Semiconductor and its officers, employees, subsidiaries, affiliates, and distributors harmless against all claims, costs, damages, and expenses, and reasonable attorney fees arising out of, directly or indirectly, any claim of personal injury or death associated with such unintended or unauthorized use, even if such claim alleges that Freescale Semiconductor was negligent regarding the design or manufacture of the part.

Freescale™ and the Freescale logo are trademarks of Freescale Semiconductor, Inc. All other product or service names are the property of their respective owners.  
© Freescale Semiconductor, Inc. 2004.