

The comparators' hysteresis
 $V_H = 240\text{mV}$

$u+ < 15\text{V}$
 $u+ = 2 * V_{\text{sense_DCB_half_15}}$
 $u+ = 13.30\text{V}/13.06\text{V} @ 400\text{V}$

$u+ < 15\text{V}$
 $u+ = 2 * V_{\text{sense_DCB_half_15}}$
 $u+ = 13.30\text{V}/13.06\text{V} @ 400\text{V}$

$u+ < 15\text{V}$
 $u+ = 2 * V_{\text{sense_DCB_half_15}}$
 $u+ = 13.30\text{V}/13.06\text{V} @ 400\text{V}$

$u- = 6.60\text{V} @ 400\text{V}$

Brake ON at
 DC Bus > 350V
 (2.888V)

$u- < 7.5\text{V}$
 $u- = 6.60\text{V} @$
 DC-Bus = 400V

330k and 150k resistors have "SM/R_1206" footprint
 in order to withstand high voltage drop (<200V).

5
4
3
2
1

5
4
3
2
1

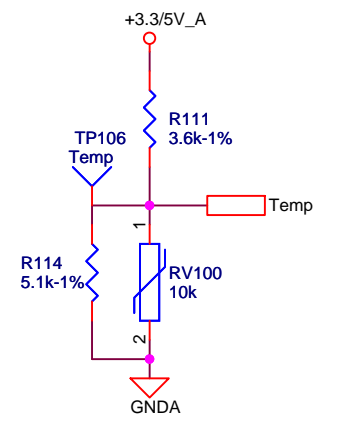
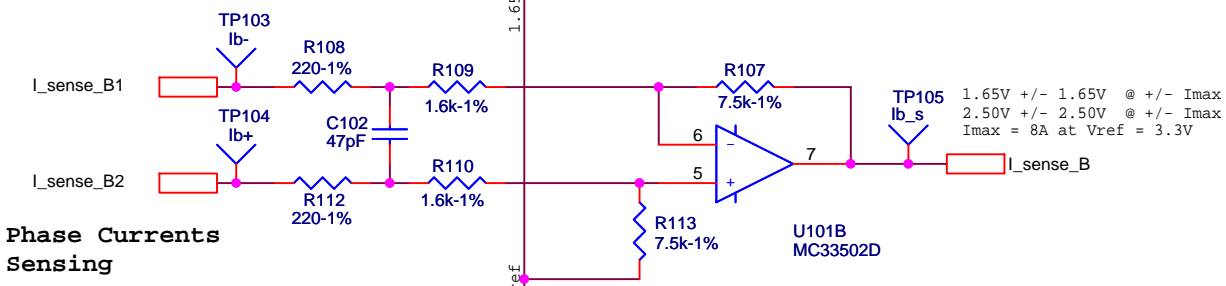
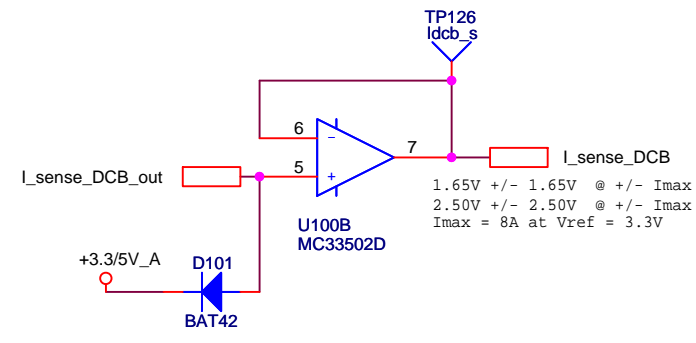
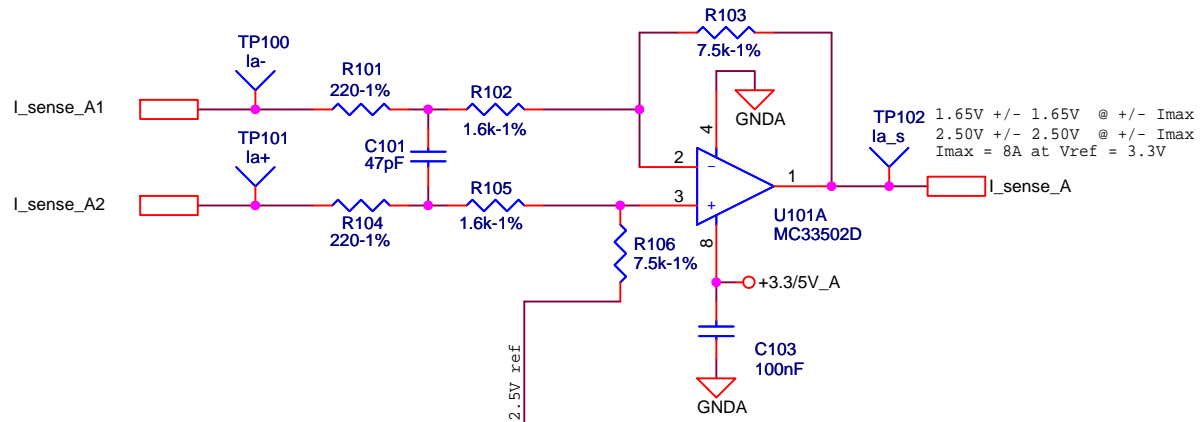

Phase Currents Sensing

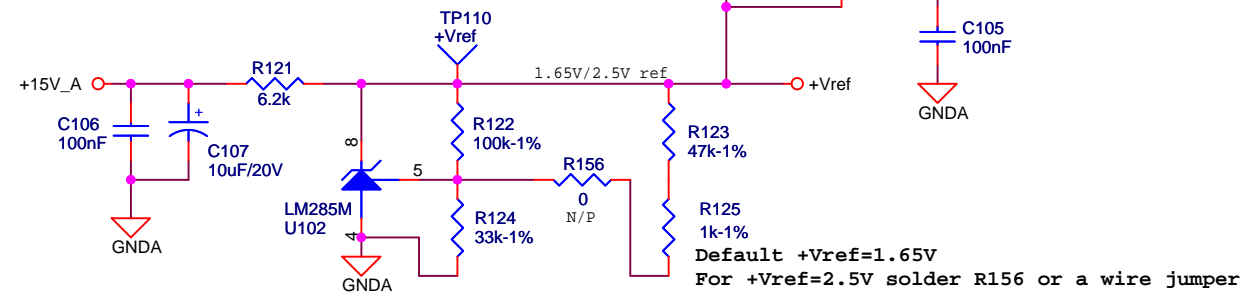
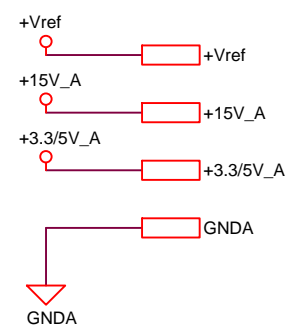
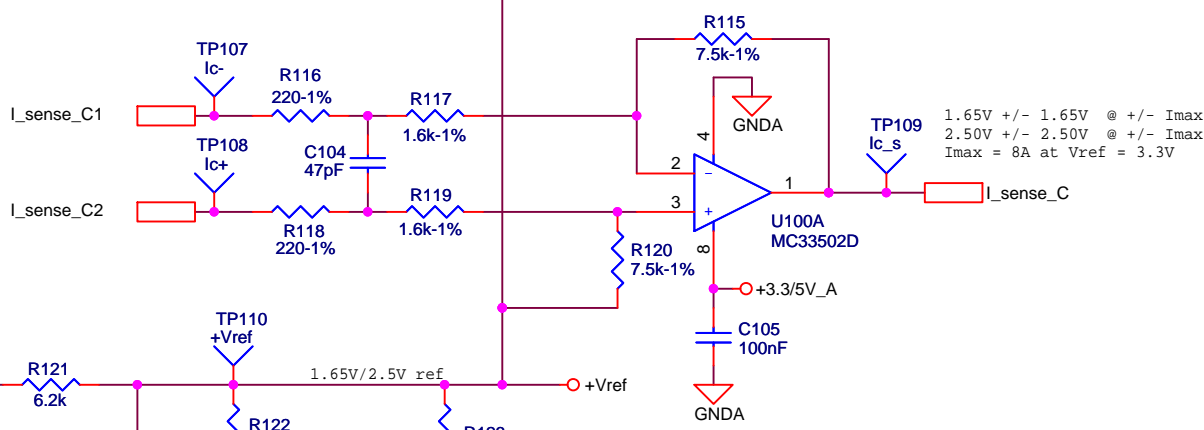

5 4 3 2 1

D C B A

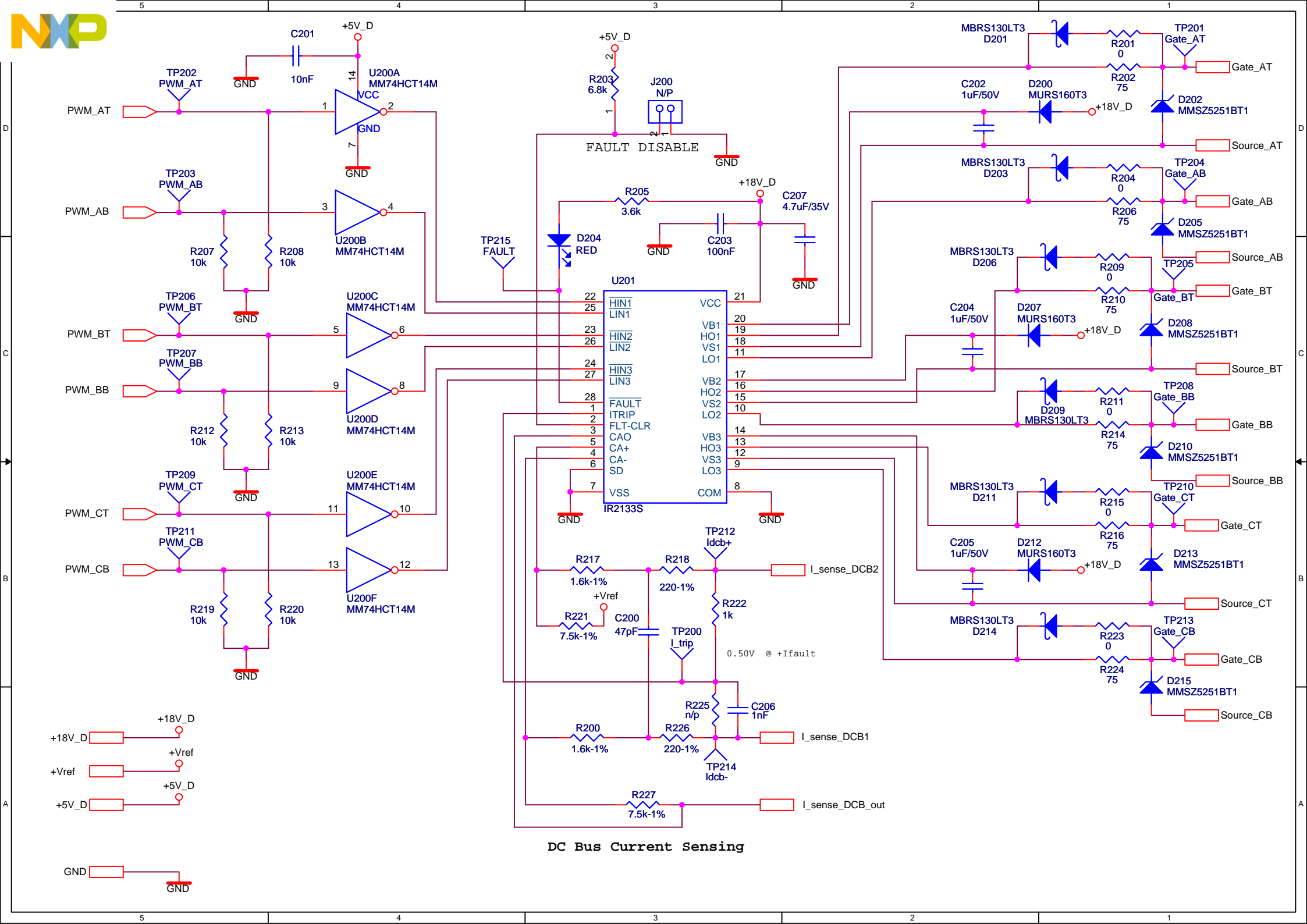

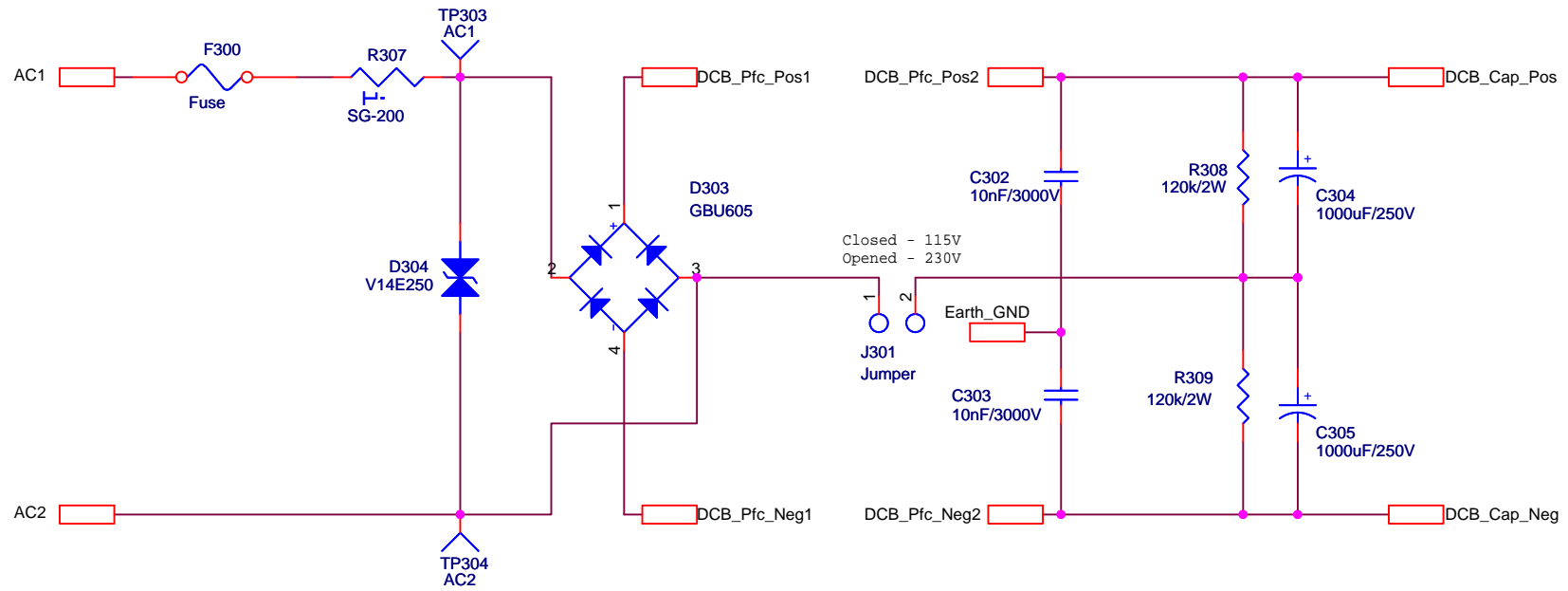

D

C

B

A

D

C

B

A

