

PMSM Electrical Parameters Measurement

by: Viktor Bobek

1 Introduction

The vector control, also known as the field-oriented control (FOC), of a permanent magnet synchronous motor (PMSM) is the algorithm often used in today's advanced motor control drives. Such advanced motor control algorithms require the setting of motor electrical parameters for its proper functionality. This application note deals with the measurement of electrical parameters needed for vector control of PMSM. The electrical parameters are needed to set the current PI controller gains to get the desired closed-loop performance and for BEMF observer constants. The proposed measurement techniques determine a number of pole pairs, a stator resistance, synchronous inductances, and an electrical constant with common measurement equipment. A summary of PMSM sensorless control and explanation of motor control terms can be found in [1].

2 Motor parameters needed for PMSM FOC

One of the possible methods to set the PI controller gains, is to calculate them from motor parameters. The current PI controller gains in time domain are calculated from the motor electrical parameters [1]; see the following equations.

Contents

1	Introduction.....	1
2	Motor parameters needed for PMSM FOC.....	1
3	Motor pole pairs.....	3
3.1	Background.....	3
3.2	Guide.....	3
4	Stator resistance.....	5
4.1	Background.....	5
4.2	Guide.....	5
5	Synchronous inductances.....	7
5.1	Background.....	7
5.2	Guide.....	11
6	Back-EMF constant.....	12
6.1	Background.....	12
6.2	Guide.....	13
7	Conclusion.....	14
8	References.....	14
9	Acronyms and Abbreviated Terms.....	15

$$K_p = 2\xi\omega_0L - R$$

Equation 1

$$K_i = \omega_0^2L$$

Equation 2

Where ω_0 is the natural frequency of the current closed-loop system (loop bandwidth) and ξ is the current loop attenuation. Therefore, the PMSM vector control algorithm typically requires the following parameters.

Table 1. Electrical parameters needed for FOC

Electrical parameters needed for FOC current PI controller gains calculation			
Parameter	Dimension	Description	Used in constant calculation
R_s	(Ω)	Resistance one of the motor phase	Current PI controller BEMF Observer
L_d	(H)	d -axis inductance of one motor phase	Current PI controller BEMF Observer
L_q	(H)	q -axis inductance of one motor phase	Current PI controller BEMF Observer
Additional electrical parameters needed for FOC			
K_e	(V.s/rad)	Electrical constant	BEMF Observer
p	(-)	Motor pole pairs	Speed and position mechanical/electrical quantities recalculation

The speed PI controller gains in time domain are calculated from the motor/load mechanical parameters; see [Equation 1 on page 1](#) and [Equation 2 on page 2](#)

$$K_{p\omega} = 2\xi_{\omega}\omega_{0\omega}J$$

Equation 3

$$K_{i\omega} = \omega_0^2J$$

Equation 4

Where $\omega_{0\omega}$ is the natural frequency of the speed closed-loop system (loop bandwidth) and ξ is the speed loop attenuation. Therefore, the PMSM vector control algorithm typically requires the following parameters.

Table 2. Mechanical/load parameters needed for FOC speed PI controller gains calculation

Parameters	Dimension	Description	Used in constant calculation
J	(kg.m ²)	Total mechanical inertia	Speed PI controller
B_m	(N.m.s)	Viscous friction coefficient	More precise speed PI controller gains setting

The measurement of individual electrical parameters is described in the following chapters of this application note.

3 Motor pole pairs

3.1 Background

The motor pole pairs parameter defines a ratio between mechanical and electrical quantities (mechanical vs electrical rotor position/speed). The motor pole pairs represent the number of north and south segments the rotor contains.

3.2 Guide

The equipment required to measure motor pole pairs depend on the method used for measurement.

- DC power supply
- Three-phase inverter, oscilloscope, hand velocity meter, and a current probe
- Driving motor, oscilloscope and a voltage probe

Usually, the number of the motor pole pairs is written on the label of the motor. If there is no information regarding the number of pole pairs, it can be determined. See the following subsections.

3.2.1 Method to determine low number of the pole pairs

Guide: The following steps describe the method to determine the low number of motor pole pairs. See [Figure 1](#).

1. Connect the phase A wire to the positive potential (+) and phase B and C to negative potential (-) of the voltage source.
2. Set a current limit of the power supply to such a level so that the user is able to rotate the shaft manually, and the rotor is aligned in the stable position. Common current limit is about 10% of the rated motor current. For more powerful motor, the current limit is lower.
3. Draw a line/sign for every stable position in which the rotor is aligned.
4. Number of stable positions is equal to the motor pole pairs.

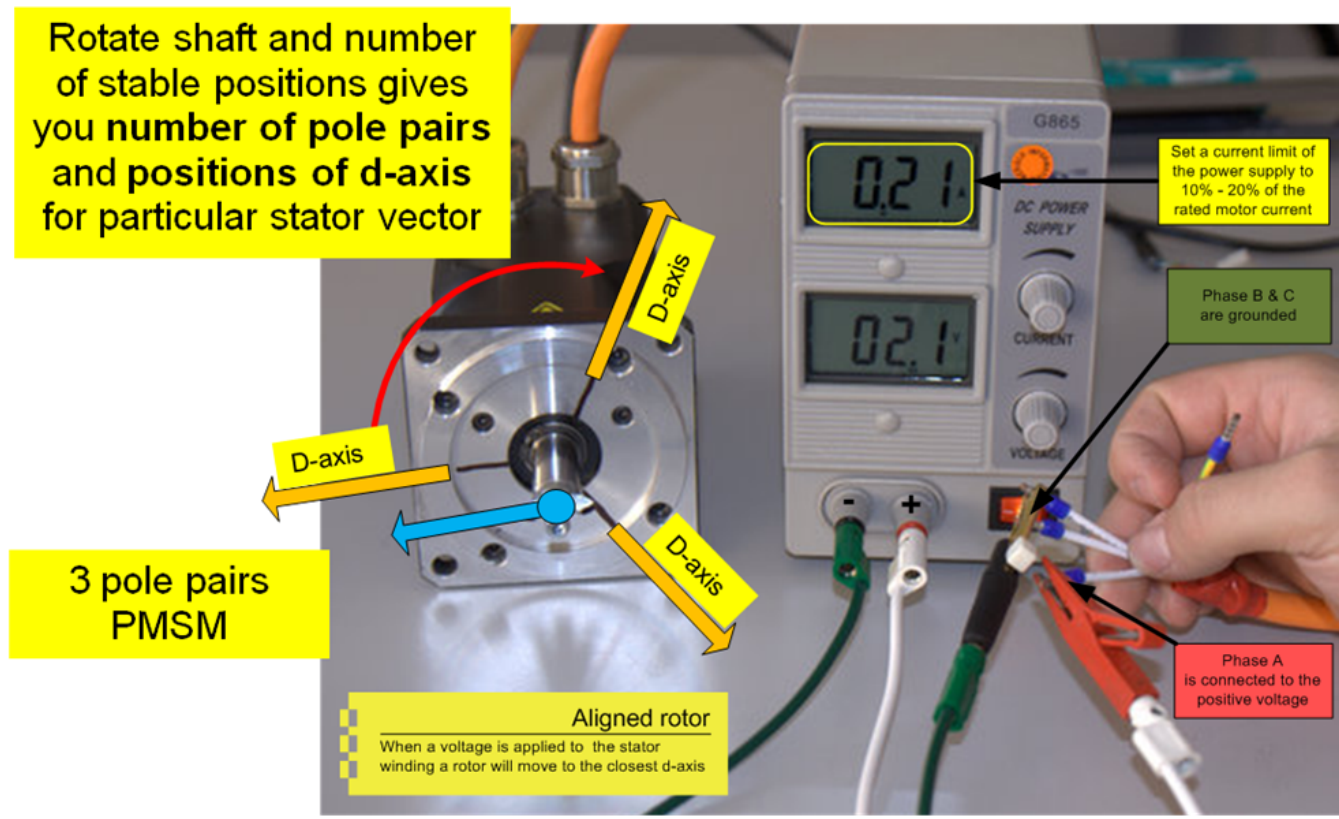

Figure 1. Method for the determination of low number of pole pairs

3.2.2 Method to determine high number of the pole pair

It is possible to use two methods for determination high number of pole pairs. Selection of the method depends on available measuring equipment. An oscilloscope is required for measurement in both the methods

- **Method A:** a current probe and an inverter using Volt/Herz method to spin the motor with unknown parameters
- **Method B:** a voltage probe and driving motor, which spins the motor

Guide for Method A: The following steps describe the method to determine the high number of motor pole pairs.

1. Spin the motor by an inverter using Volt/Herz method and set the frequency in such a way that the motor will spin at a constant, and preferably higher speed.
2. Measure the phase current frequency using oscilloscope current probe. The frequency of the phase current must be the same as that generated by Volt/Herz method.
3. Measure the speed of the motor by some hand velocity meter. The speed reading must be constant.
4. Calculate the number of pole pairs using the equation given below. The result should be very close to an integer number.

$$pp = \frac{60f}{n} = \frac{60 \cdot 45.05}{112} = 24$$

Equation 5

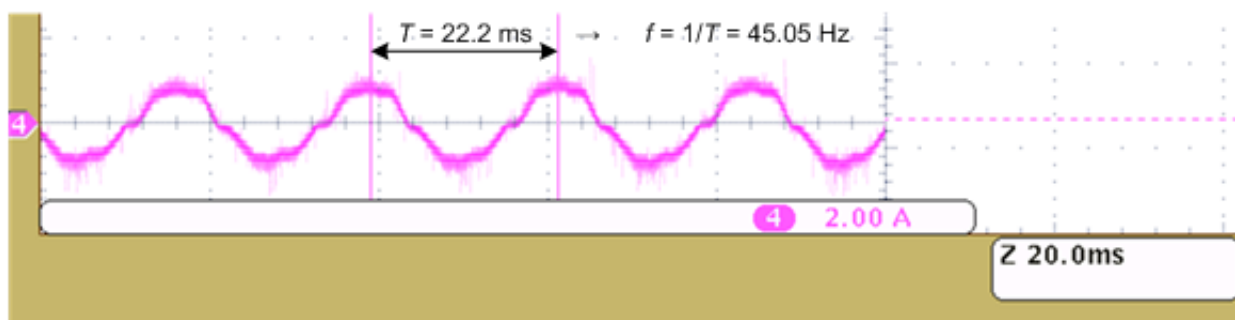

Figure 2. Current waveform for the determination of high number of the pole pair

Guide for Method B: The following steps describe the method to determine the high number of motor pole pairs.

1. Spin the motor by an external driving motor at a constant speed.
2. Measure the generated voltage frequency.
3. Measure the speed of the motor by some hand velocity meter.
4. Calculate the motor pole pairs using [Equation 5 on page 4](#).

4 Stator resistance

4.1 Background

A resistance of the stator winding R_s is defined as a resistance between a phase terminal and the center of the winding. The winding resistance is temperature dependent. Usually the resistance value at 25°C or specified temperature is listed in the motor's datasheet.

Calculate resistance R at operational temperature t ($^\circ\text{C}$) of stator winding (if the temperature is known), using the resistance value measured at temperature t_0 ($^\circ\text{C}$).

$$R = R_0(1 + \alpha\Delta t)$$

Equation 6

where α is the constant determined by the material (for copper, $\alpha = 0.004 \text{ K}^{-1}$)

$$\Delta t = 75^\circ\text{C} - 25^\circ\text{C} = 50^\circ\text{C}$$

Equation 7

For 50°C temperature difference, R can be calculated as given below.

$$R = 1.2R_0$$

Equation 8

4.2 Guide

The equipment required to measure stator resistance depend on the method used for measurement:

- Digital multimeter
- RLC meter

4.2.1 Digital multimeter

Higher values of stator resistance ($> 10 \Omega$) can be measured by a digital multimeter. The usual stator winding configuration is the wye, so the final stator resistance is half of the measured resistance. The following figure shows the stator resistor measurement using a digital multimeter.

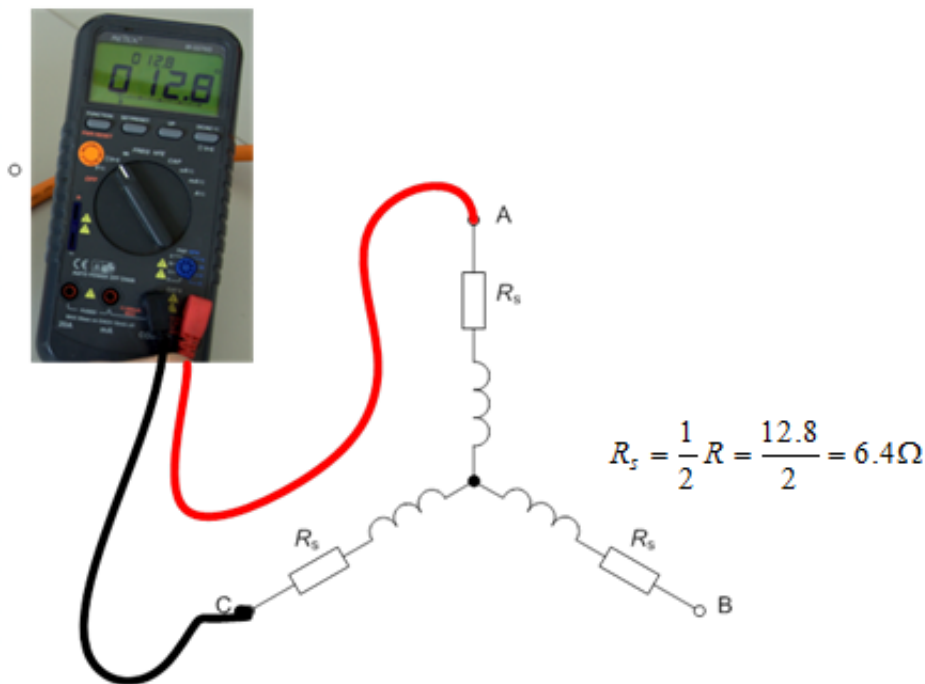

Figure 3. Stator resistance measurement by a digital multimeter

4.2.2 RLC meter

Lower values of stator resistance can be measured by an RLC meter, for example MOTECH MT 4080A. The four-terminal measurement reduces the effect of the test lead resistance. See Figure 4. Usual measurement range is between (10 mΩ–10 kΩ). Before the measurement, calibrate the RLC meter (open-circuit, and short circuit). The usual stator winding configuration is the wye, so the final stator resistance is half of measured resistance.

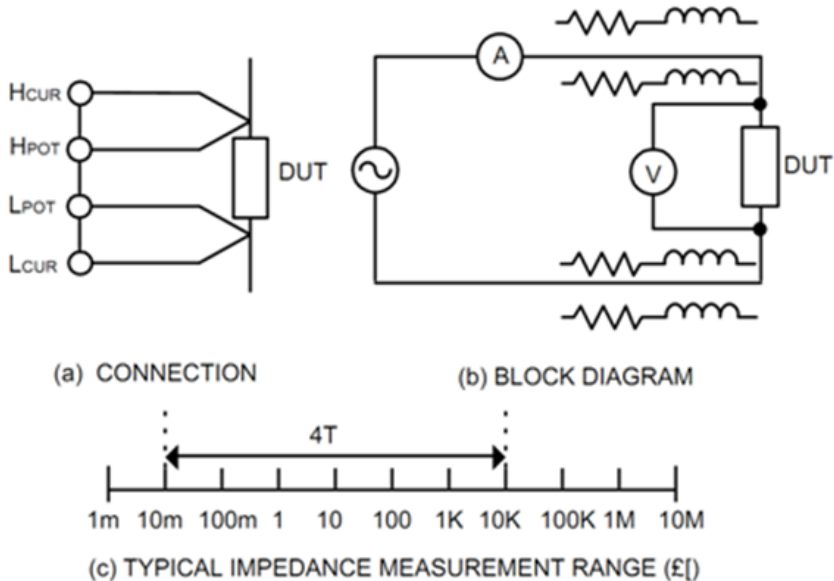

Figure 4. Four-terminal measurement schematic

5 Synchronous inductances

5.1 Background

The synchronous inductances of Interior Permanent Magnet Synchronous Motor (IPMSM) winding are different ($L_d < L_q$), because of lower reluctance in q -axis. The synchronous inductances of Surface Mounted Permanent Magnet Synchronous Motor (SMPM) motor are almost equal, because the permanent magnets are surface mounted and reluctance is the same in every position, that is:

$$\mu_{PM} \approx \mu_{air} \rightarrow L_d \approx L_q$$

where μ_{PM} is the relative permeability of the permanent magnet, and μ_{air} is the relative permeability of the air.

See the following figure depicting the reluctance paths of d - and q -axis in IPMSM.

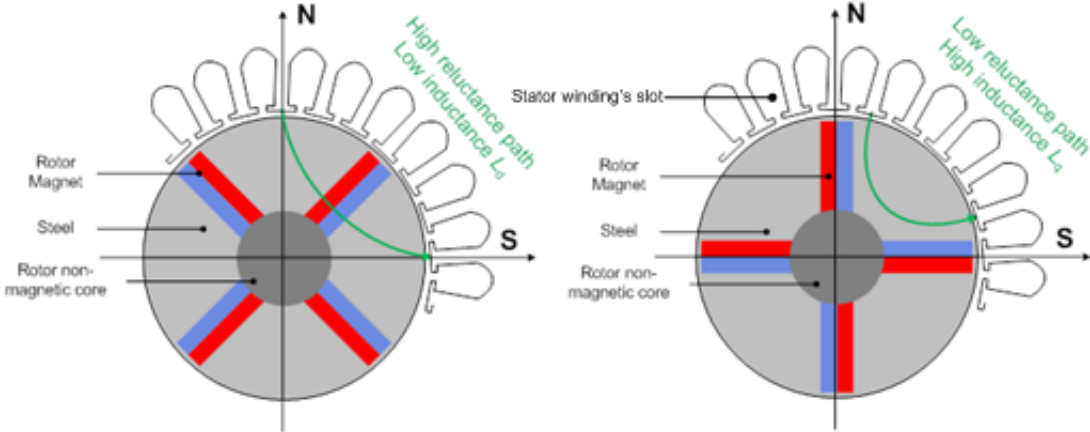

Figure 5. Reluctance paths in d - and q -axis of IPMSM

Synchronous inductances

In practice, magnetic circuits are subject to saturation as the current increases. Especially, when current I_q is increased, the value of L_q is decreased. Since I_d is maintained to zero or negative value (demagnetizing) in most operating conditions, saturation of L_d rarely occurs. The flux linkage λ_m and L_d are subject to armature reaction. See the following figure.

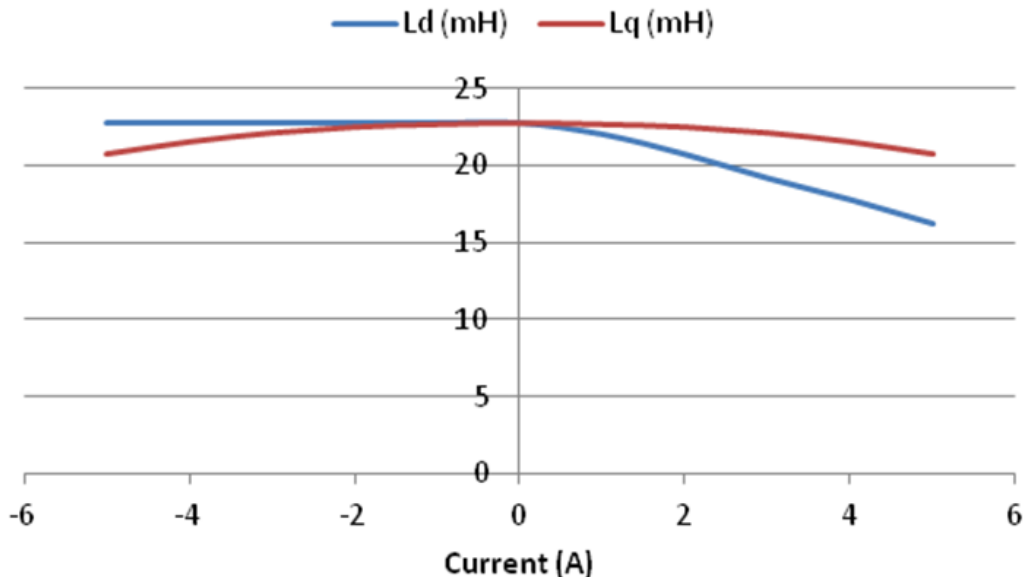

Figure 6. Typical inductance characteristic of PMSM

NOTE

Majority of the applications use single value; however the determination of inductances depends on selected working conditions.

In order to measure synchronous inductance, the users must maintain balanced three-phase current condition. When the rotor is aligned with the center of phase A winding, L_d (L_q) can be derived from the measured equivalent inductance L of the circuit, as shown in the following figure.

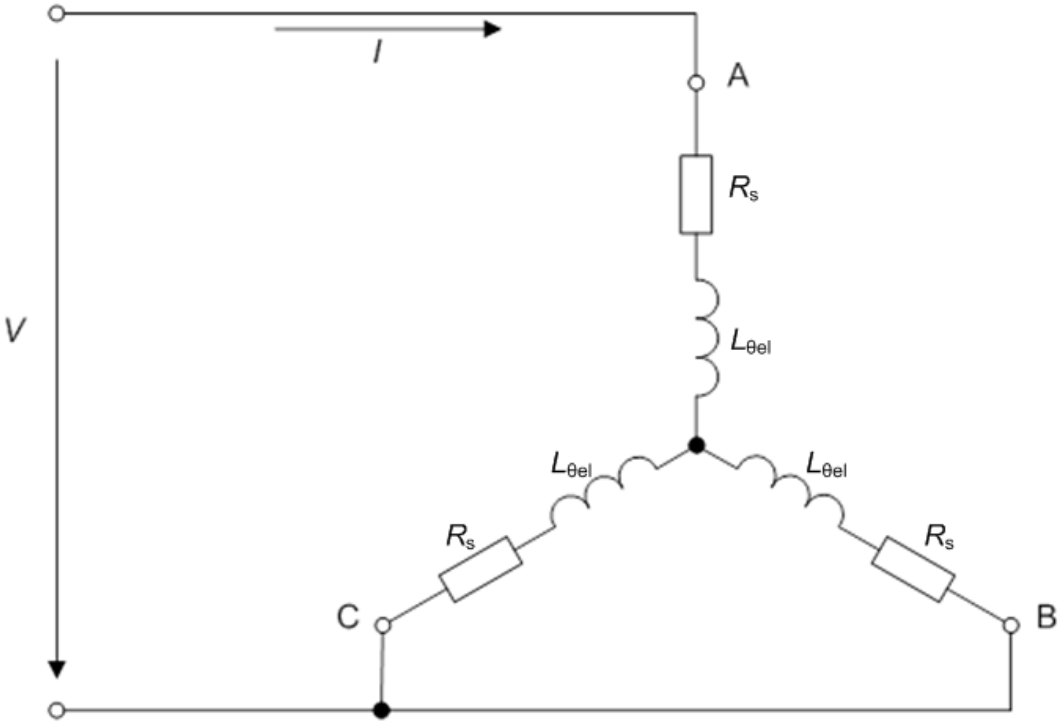

Figure 7. Inductance measurement circuit

Depending on the rotor angle θ_{el} , it is possible to measure inductance in d -axis or q -axis, where L is the total inductance for serial-parallel connection of the stator winding:

$$L_d = (2/3)L, (\theta_{el} = 0^\circ)$$

Equation 9

$$L_q = (2/3)L, (\theta_{el} = 90^\circ)$$

Equation 10

When the rotor is aligned with phase A ($\theta_{el} = 0^\circ$) and locked, then the current response is first order RL circuit.

$$i_d = \frac{V}{R}(1 - e^{-t/\tau})$$

Equation 11

Where τ is a time constant of the circuit

$$\tau = \frac{L}{R}$$

Equation 12

After measuring τ , the inductance L_d can be calculated as follows.

$$L_d = \frac{2}{3}\tau R$$

Equation 13

synchronous inductances

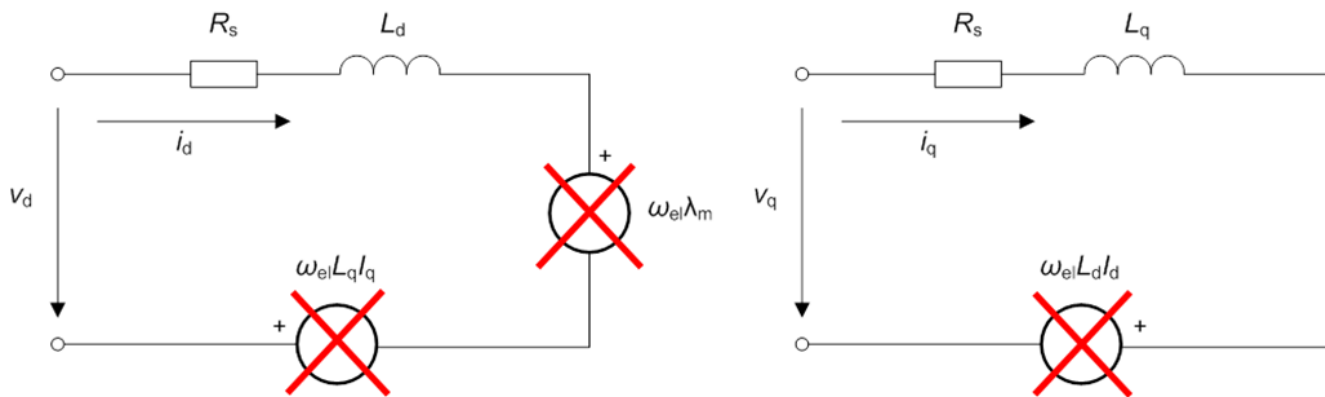

Figure 8. Equivalent phase model of PMSM in *d/q* axis for a locked rotor shaft

Since $V_d = (2/3)V$, $V_q = 0$, and I is the same as I_d and the total resistance of the circuit is $(3/2)R_s$, the equivalent inductance seen from the supply source is $(3/2)L_d$. Similar explanation can also be applied to L_q when the rotor is locked at 90° electrical.

5.1.1 Q-axis alignment

To measure the inductance in *q*-axis without an inverter, an alignment has to be done into the *q*-axis. The alignment into *d*-axis is done by phase *A* connected to the positive potential (+) and phase *B* and *C* are grounded (-). It can be seen from the following figure that 90° electrical shifted position is when phase *B* terminal is connected to the positive potential (+) of the voltage source, phase *C* is grounded (-), and phase *A* is floating (NC).

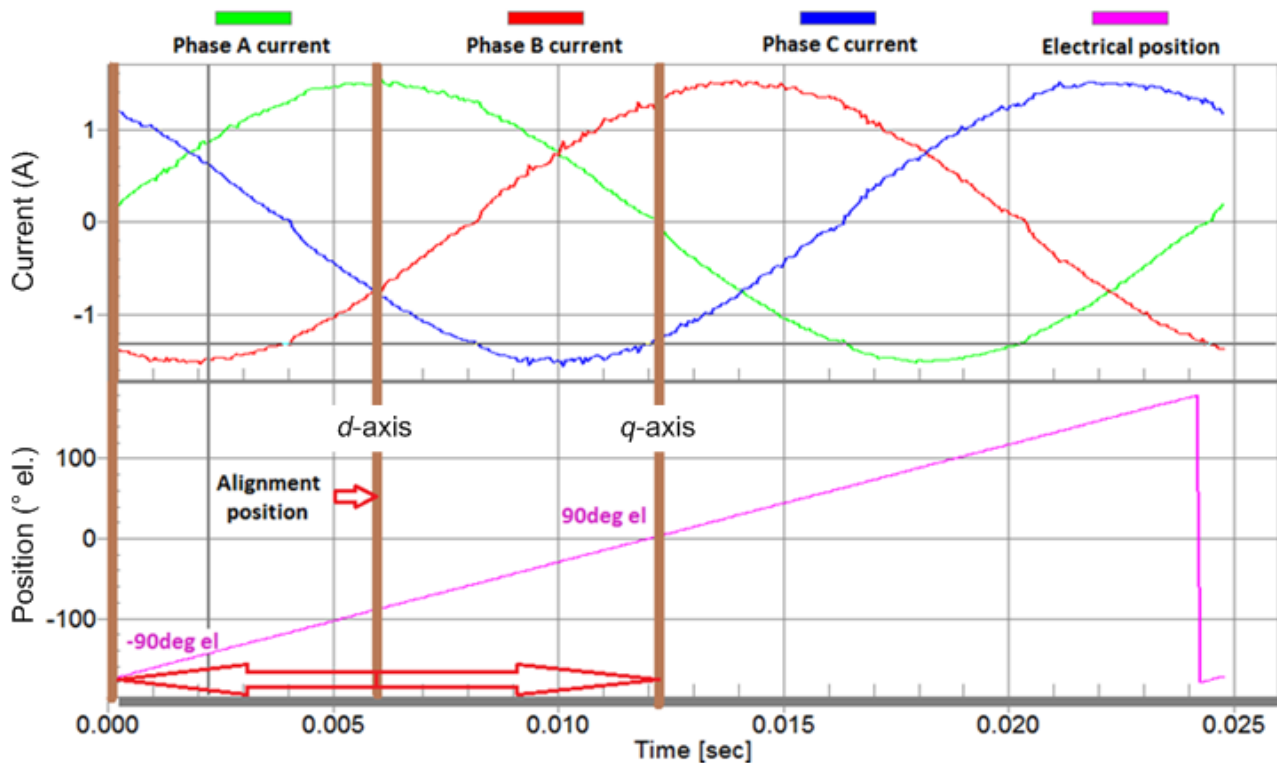

Figure 9. Explanation of *q*-axis alignment

5.2 Guide

The equipment required to measure inductances in q -axis and d -axis are as follows.

- DC power supply, oscilloscope, current and voltage probe

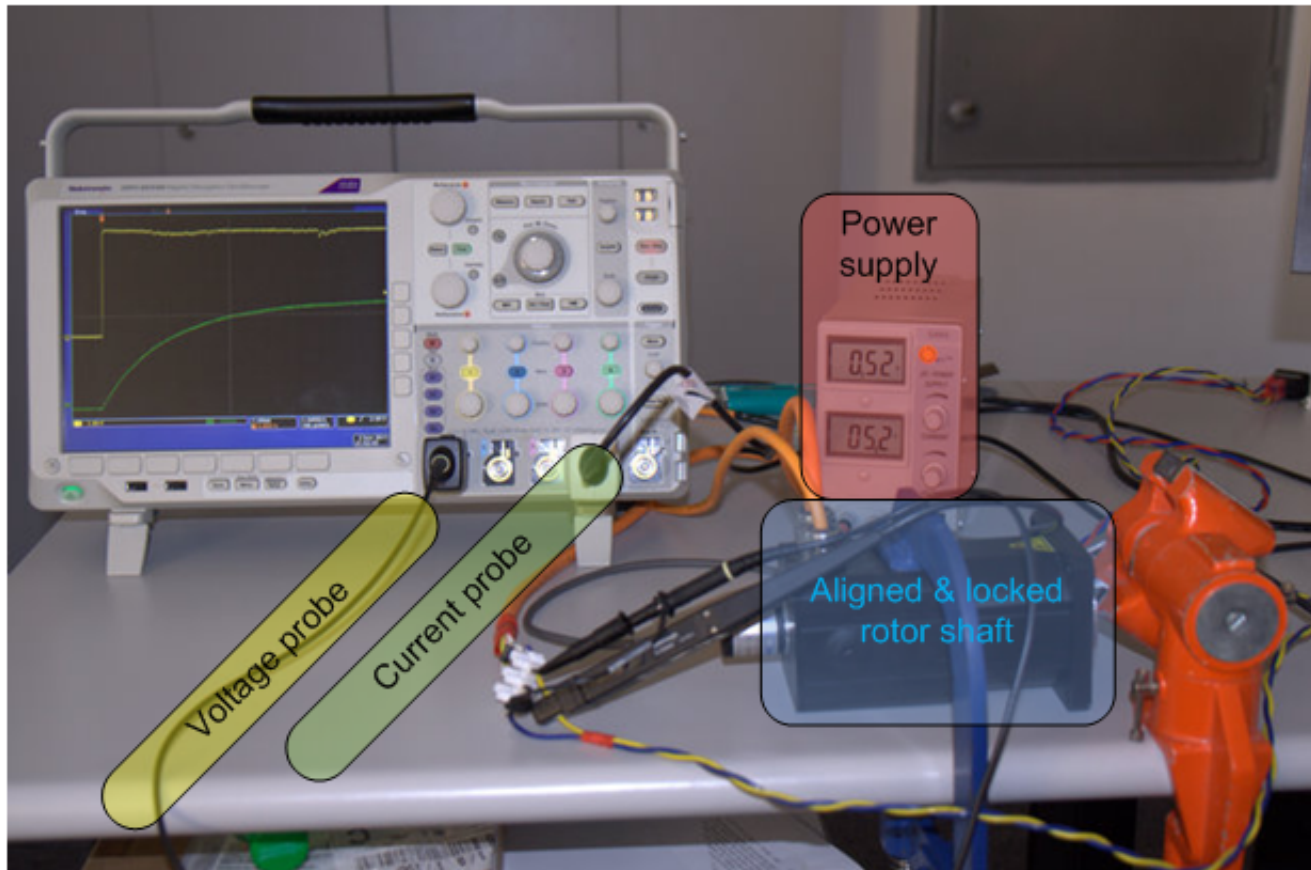

Figure 10. Set up to measure inductance in q-axis

Guide to measure d -axis inductance (non-saturated inductance measurement): Follow the steps given below to measure the d -axis inductance L_d .

1. Align the rotor to phase A. Phase A is connected to the positive potential (+) and phase B and C are grounded (-).
2. Lock the rotor shaft.
3. Apply negative step voltage. Phase A is grounded (-) and phases B and C are connected to the positive potential (+). Usual level of the current is about 10% of the rated phase current.
4. Measure the step response of the current by a current probe. See [Figure 11](#).
5. Calculate inductance L_d .

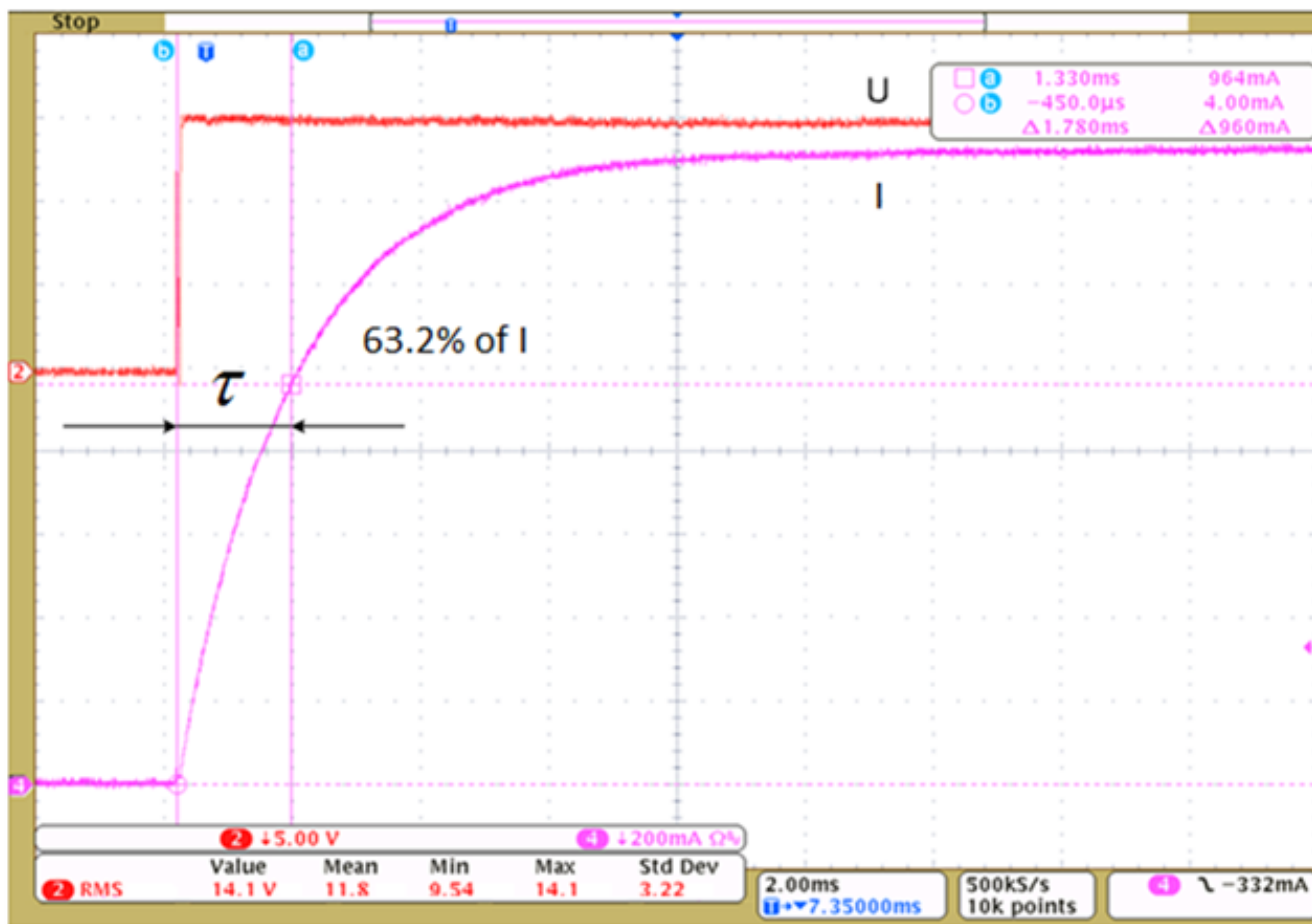

Figure 11. Current step response waveform

Guide to measure q -axis inductance: Follow the steps given below to measure the q -axis inductance L_q .

1. Align the rotor to the q -axis. Connect the phase B terminal to the positive potential (+) of the voltage source and phase C is grounded (-). Phase A terminal is floating.
2. Lock the rotor shaft firmly because current step response in q -axis creates **torque**.
3. Generate a current step response in this configuration: phase A is connected to the positive potential (+) of the voltage source and phases B and C are grounded.
4. Calculate inductance L_q in the same way as L_d .

6 Back-EMF constant

6.1 Background

The back-EMF (BEMF) constant (flux linkage of the PM denoted by λ_m) can be obtained by measuring the no-load line voltage V_{pk} of the motor while it is driven through the shaft at a constant speed of ω_m . The constant gives a ratio between BEMF voltage and the angular electrical frequency/speed.

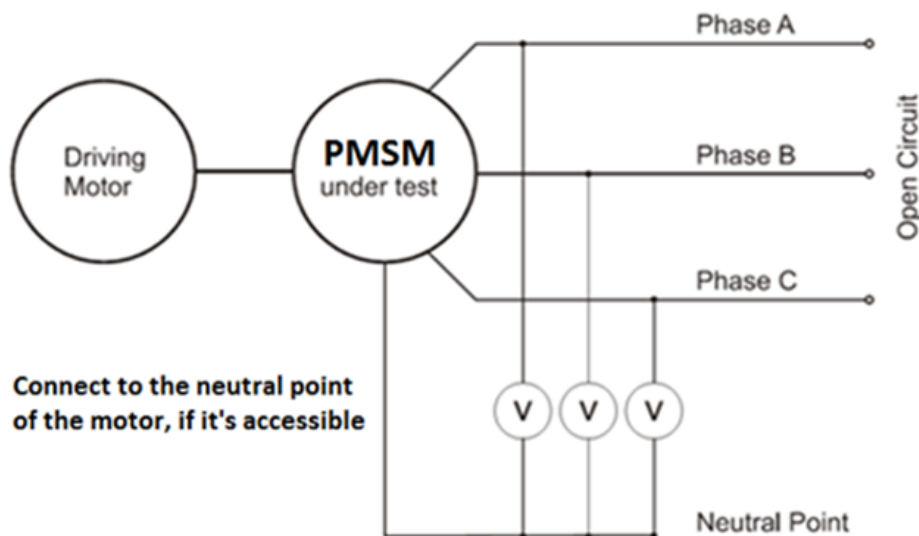

Figure 12. Three-phase measurement of the BEMF constant

6.2 Guide

The equipment required to measure the BEMF constant are listed below.

- Oscilloscope and at least one voltage probe
- Driving motor or hand drill machine

The steps given below must be followed to determine the BEMF constant.

1. Spin the motor by an external driving motor or a hand drill machine at a constant speed. Higher speed is preferred, because the voltage measurement error is lower.
2. **One-phase measurement:** Measure the generated phase voltage (between one phase terminal and neutral point of the motor). Usually the neutral point is not accessible; then measure the line-to-line voltage.

Three-phase measurement: If the neutral point is not accessible, it's possible to create the artificial neutral point from all three voltage probe clips connected together. See [Figure 13](#).

3. Calculate the Back-EMF constant according to [Equation 14 on page 13](#).

Single phase measurement (line-to-line voltage measurement):

$$k_{e_ph} = \frac{V_{pk}}{\sqrt{3} \cdot \omega_{e1}} = \frac{V_{pk-pk}}{2\sqrt{3} \cdot \omega_{e1}} = \frac{V_{pk-pk} \cdot T_{e1}}{2\sqrt{3} \cdot 2\pi} = \frac{120.8 \cdot 0.02125}{\sqrt{3} \cdot 4\pi} = 0.118 \frac{V \cdot s}{rad}$$

Equation 14

Three-phase measurement (phase voltage measurement):

$$k_e = \frac{V_{pk}}{\omega_{e1}} = \frac{V_{pk-pk}}{2\omega_{e1}} = \frac{V_{pk-pk} \cdot T_{e1}}{2 \cdot 2\pi} = \frac{47.8 \cdot 0.03139}{4\pi} = 0.119 \frac{V \cdot s}{rad}$$

Equation 15

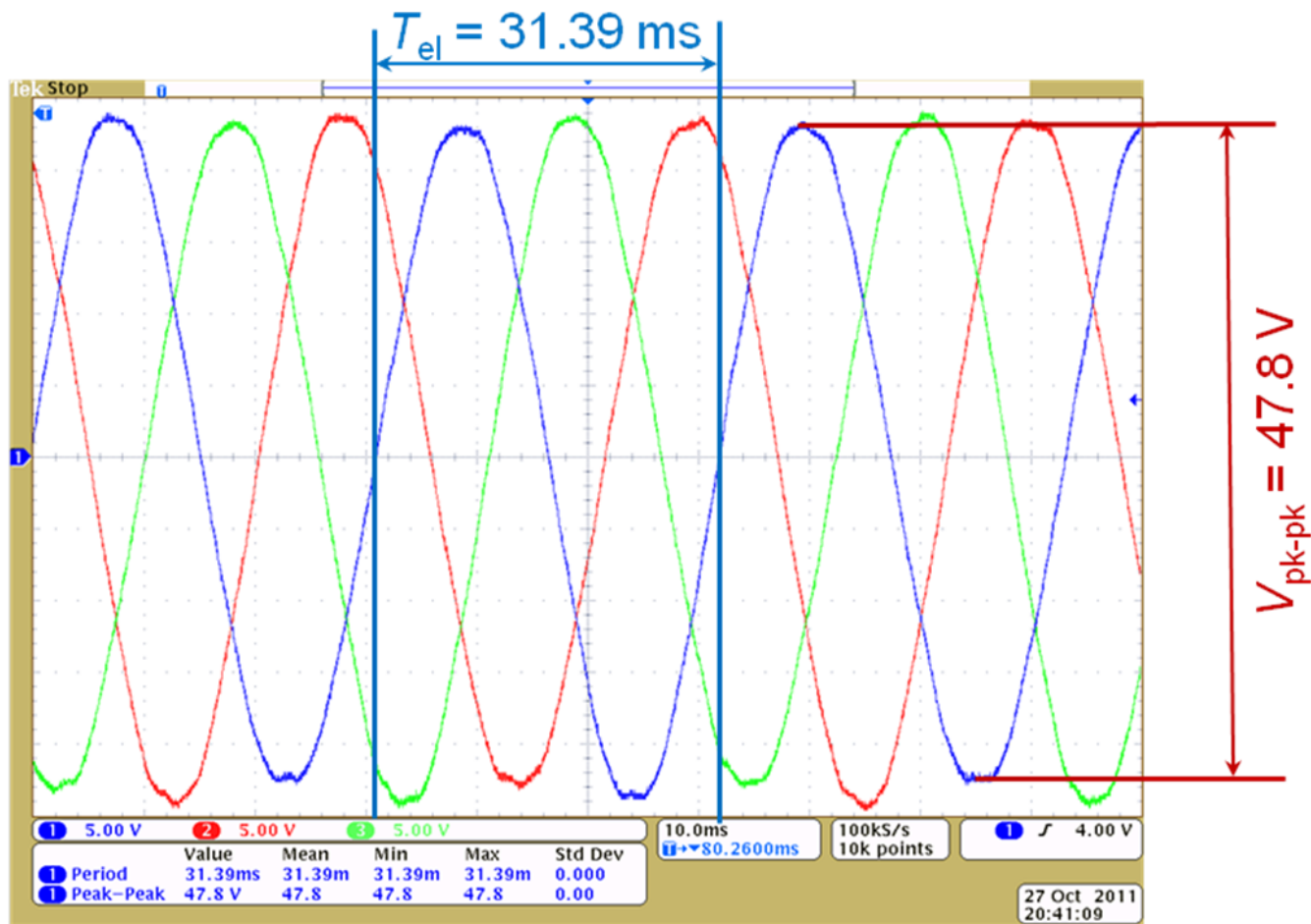

Figure 13. Three-phase oscilloscope measurement of the electrical constant

7 Conclusion

The application note summarizes methods for determining electrical parameters of PMSM. The precise parameters determination is needed for sensorless control applications and desired closed-loop performance. The proposed measurement techniques determine the number of pole pairs, the stator windings resistance, the synchronous inductances, and the electrical constant with common measurement equipment. The parameters are determined using measured applied voltages and responding currents. A single-phase DC voltage power supply can be used to determine the synchronous inductances of three-phase PMSM with sufficient accuracy.

8 References

1. DRM110: Sensorless PMSM Control for an H-axis Washing Machine Drive, available on freescale.com.
2. MOTech 4080A Operation Manual, available at motech.com.tw

9 Acronyms and Abbreviated Terms

The following table contains acronyms and abbreviated terms used in this document.

Table 3. Acronyms and Abbreviated Terms

Term	Meaning
d -axis	Direct axis
f	Frequency (Hz)
IPMSM	Interior Permanent Magnet Synchronous Motor
n	Mechanical speed (rpm)
NC	Not Connected
PMSM	Permanent Magnet Synchronous Motor
q -axis	Quadrature axis
SMPM	Surface Mounted Permanent Magnet Synchronous Motor
θ_{el}	Electrical rotor position
μ_{Air}	Relative permeability of the air
μ_{PM}	Relative permeability of the permanent magnet

How to Reach Us:

Home Page:

www.freescale.com

Web Support:

<http://www.freescale.com/support>

USA/Europe or Locations Not Listed:

Freescale Semiconductor
Technical Information Center, EL516
2100 East Elliot Road
Tempe, Arizona 85284
+1-800-521-6274 or +1-480-768-2130
www.freescale.com/support

Europe, Middle East, and Africa:

Freescale Halbleiter Deutschland GmbH
Technical Information Center
Schatzbogen 7
81829 Muenchen, Germany
+44 1296 380 456 (English)
+46 8 52200080 (English)
+49 89 92103 559 (German)
+33 1 69 35 48 48 (French)
www.freescale.com/support

Japan:

Freescale Semiconductor Japan Ltd.
Headquarters
ARCO Tower 15F
1-8-1, Shimo-Meguro, Meguro-ku,
Tokyo 153-0064
Japan
0120 191014 or +81 3 5437 9125
support.japan@freescale.com

Asia/Pacific:

Freescale Semiconductor China Ltd.
Exchange Building 23F
No. 118 Jianguo Road
Chaoyang District
Beijing 100022
China
+86 10 5879 8000
support.asia@freescale.com

Information in this document is provided solely to enable system and software implementers to use Freescale Semiconductors products. There are no express or implied copyright licenses granted hereunder to design or fabricate any integrated circuits or integrated circuits based on the information in this document.

Freescale Semiconductor reserves the right to make changes without further notice to any products herein. Freescale Semiconductor makes no warranty, representation, or guarantee regarding the suitability of its products for any particular purpose, nor does Freescale Semiconductor assume any liability arising out of the application or use of any product or circuit, and specifically disclaims any liability, including without limitation consequential or incidental damages. "Typical" parameters that may be provided in Freescale Semiconductor data sheets and/or specifications can and do vary in different applications and actual performance may vary over time. All operating parameters, including "Typicals", must be validated for each customer application by customer's technical experts. Freescale Semiconductor does not convey any license under its patent rights nor the rights of others. Freescale Semiconductor products are not designed, intended, or authorized for use as components in systems intended for surgical implant into the body, or other applications intended to support or sustain life, or for any other application in which failure of the Freescale Semiconductor product could create a situation where personal injury or death may occur. Should Buyer purchase or use Freescale Semiconductor products for any such unintended or unauthorized application, Buyer shall indemnify Freescale Semiconductor and its officers, employees, subsidiaries, affiliates, and distributors harmless against all claims, costs, damages, and expenses, and reasonable attorney fees arising out of, directly or indirectly, any claim of personal injury or death associated with such unintended or unauthorized use, even if such claims alleges that Freescale Semiconductor was negligent regarding the design or manufacture of the part.

RoHS-compliant and/or Pb-free versions of Freescale products have the functionality and electrical characteristics as their non-RoHS-complaint and/or non-Pb-free counterparts. For further information, see <http://www.freescale.com> or contact your Freescale sales representative.

For information on Freescale's Environmental Products program, go to <http://www.freescale.com/epp>.

Freescale™ and the Freescale logo are trademarks of Freescale Semiconductor, Inc. All other product or service names are the property of their respective owners.

© 2013 Freescale Semiconductor, Inc.