

Digital Home Center Platform with Axentra Software

The very rapid adoption of digital media such as downloadable music, video games and movies has created a strong demand for converged network platforms to distribute media content throughout the home. Consumers need a unified platform that connects all digital networked devices within the home and provides unified content and services management from anywhere in the world.

The MPC8313E-RDB is a turnkey hardware/software reference platform ideal as a “location-free control access” residential gateway solution. This reference platform is based on the MPC8313E PowerQUICC® II Pro processor, containing an e300 core, built on Power Architecture™ technology, and HipServ™ software platform from Axentra, a leading provider of personal digital content and services software for the digital home.

MPC8313E-RDB reference platform helps you manage your digital devices remotely from just about anywhere in the globe.

These include:

- Internet gateway
- Router
- Wi-Fi access point
- Digital content/media server
- Home automation
- PC
- Home-bound content remote access and sharing
- Backup server

The Digital Home

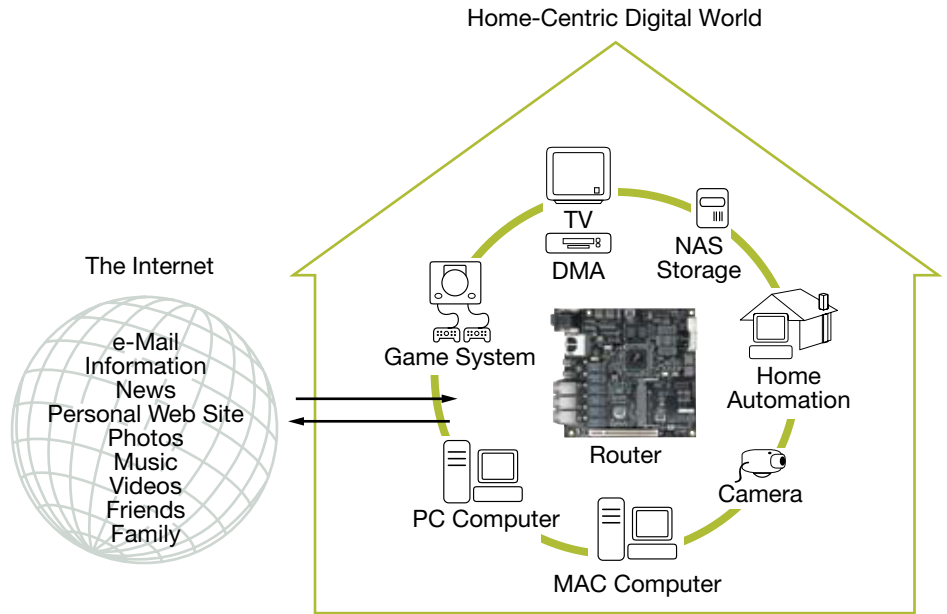

The MPC8313E microprocessor supports dual 10/100/1000 Mbps Ethernet controllers, single 32-bit PCI controller, integrated security engine, USB 2.0 host, 4-channel direct memory access (DMA), dual universal asynchronous receiver/transmitter (DUART), serial peripherals, general purpose I/O and system timers. The introduction of Gigabit Ethernet (SGMII), High-Speed USB 2.0, and low-power management makes it unique in the marketplace.

For extremely precise clock synchronization for applications such as time-sensitive telecommunications services, industrial

network switches, powerline networks and test/measurement devices, the MPC8313E features integrated IEEE® 1588 time synchronization, the leading-edge standard.

In addition to the highly integrated MPC8349E processor, the reference platform leverages external components to support these additional features:

- Five-port Gigabit Ethernet switch
- Two High-Speed USB ports
- Serial ATA ports
- PCI slot, MiniPCI slot and SD memory slot

Axentra's Location-Free Access and Control Software

The HipServ software platform is a comprehensive and unified environment to allow home users to easily utilize various content on different devices within the home or access the content from anywhere, anytime. Home users are increasingly creating more digital content and need a single environment to better manage, access, share and backup their critical home-created content. This innovative software platform also allows users to access and share their home content using mobile devices.

Key Features

- Content remote access, sharing, publishing (home-based content)
- Unified operating environment and interface to central access to any content
- Auto backup from PC/MAC to central storage or remote storage
- Media management and server (UPnP™-AV)
- Home surveillance (Internet camera)
- Remote desktop access (PC/MAC)
- Easy management of photos, music and videos

www.axentra.com

MPC8313E Reference Design

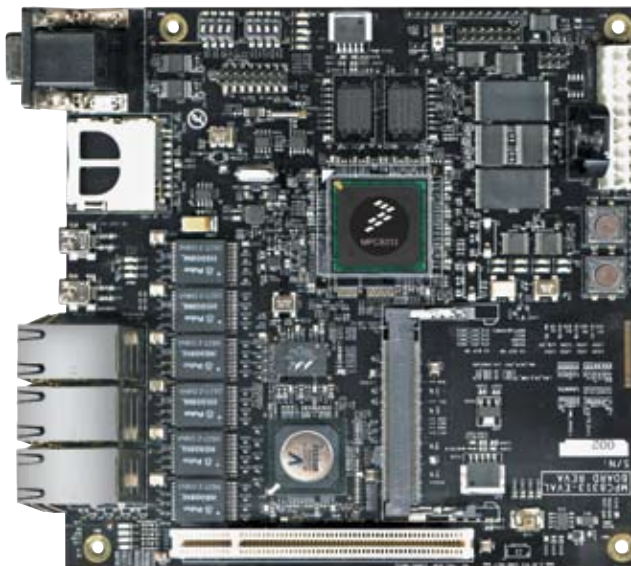
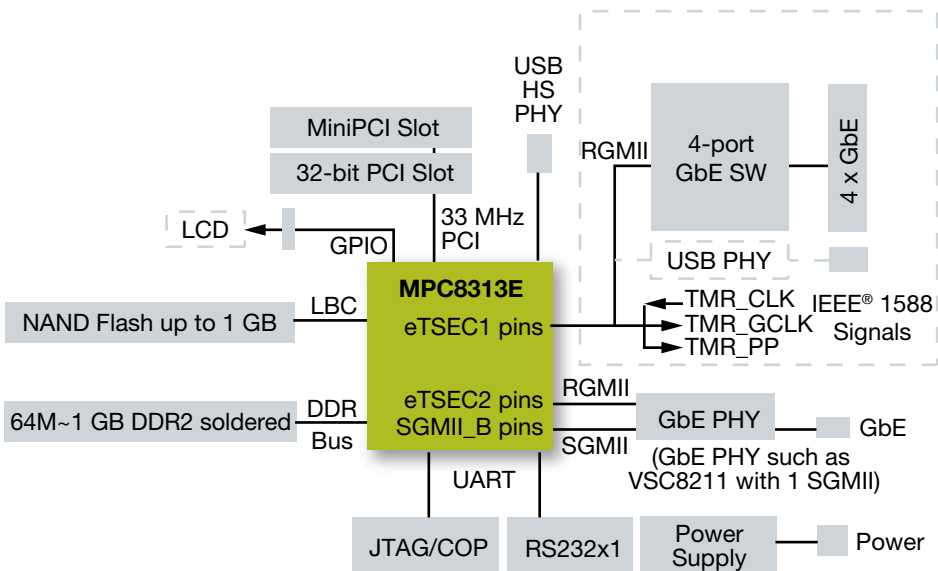

Learn More:

For current information about Freescale products and documentation, please visit www.freescale.com.



Freescale® and the Freescale logo are trademarks of Freescale Semiconductor, Inc. All other product or service names are the property of their respective owners. The Power Architecture and Power.org word marks and the Power and Power.org logos and related marks are trademarks and service marks licensed by Power.org.
© Freescale Semiconductor, Inc. 2007

Document Number: AXENTRAFS
REV 2

