

MOTOROLA		Motorola MCSL Roznov 1. maje 1009 756 61 Roznov p. R., Czech Republic, Europe
Title 3-ph. Low Voltage Give-Away Power Stage		
Author: Jaroslav Musil		
Size A3	Schematic Name: 00190_00	Rev 00
Design File Name: D:\NXPFILES\9412\2002\51TOP\00190.DSN		
Modify Date: Wednesday, March 10, 2004	Sheet 2 of 3	PCoPI Status: Motorola General Business
Copyright Motorola 2004		

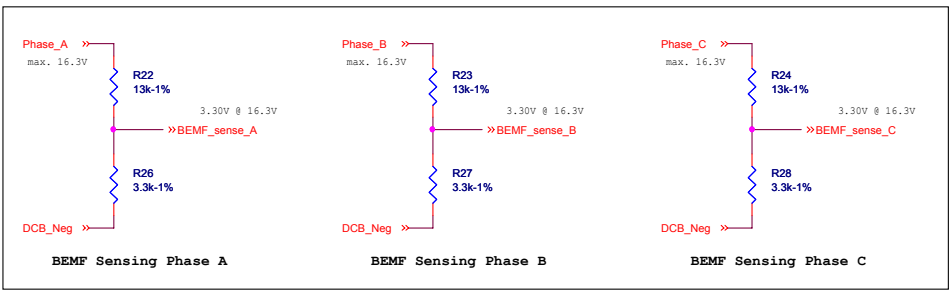

Route these capacitors according to their positions in this schematics.

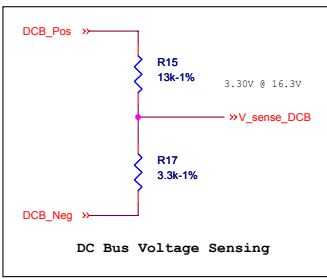
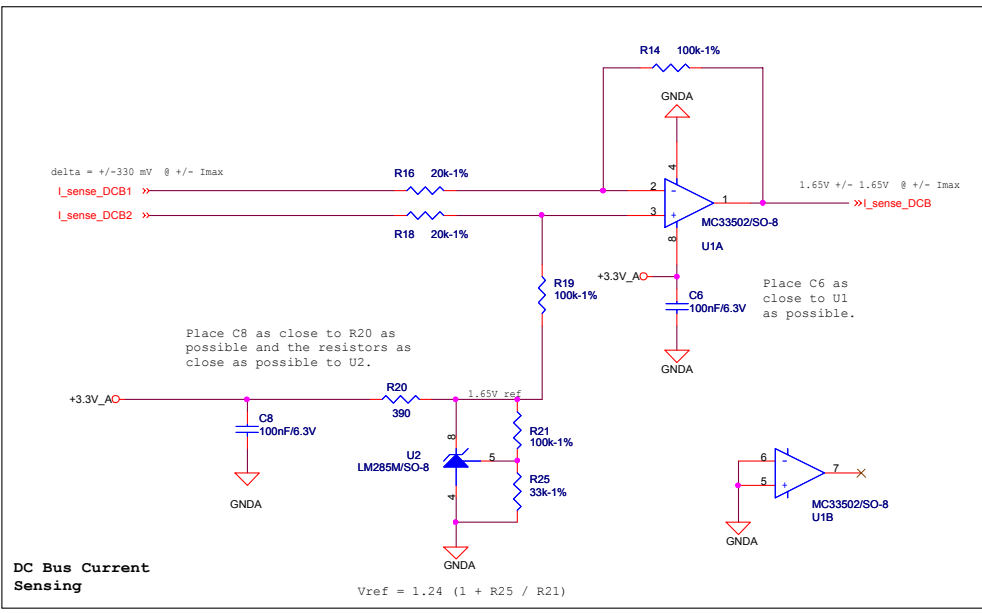
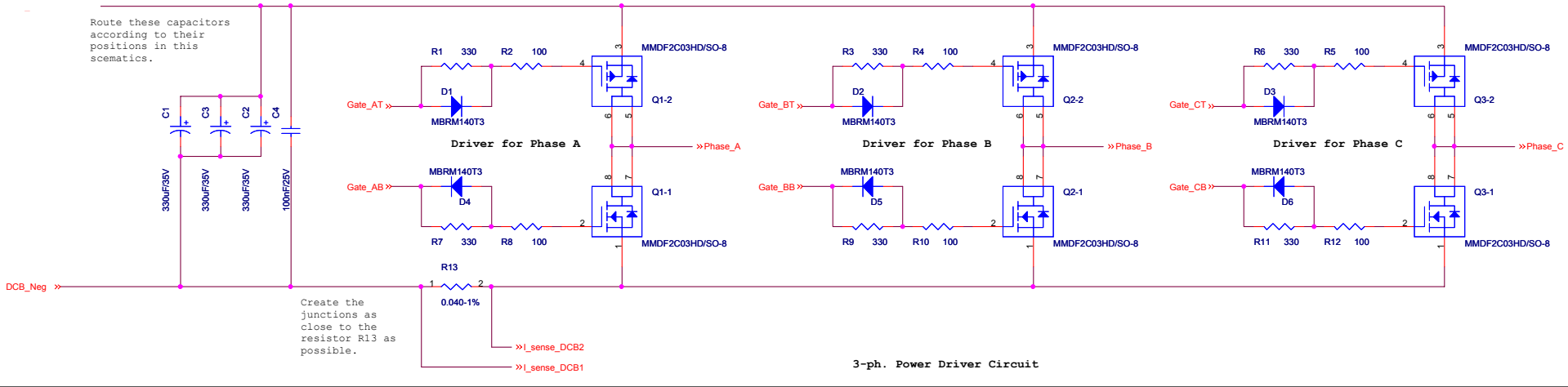

		Motorola MCSL Roznov 1. maje 1009 756 61 Roznov p. R., Czech Republic, Europe	
Title 3-ph. Low Voltage Give-Away Power Stage			
Author: Jaroslav Musil			
Size A3	Schematic Name: 00190_00	Rev 00	
Design File Name: D:\PDKFILES\91128025\CTOP00190.DSN			
Modify Date: Friday, April 16, 2004	Sheet 3 of 3		
Copyright Motorola 2004	PCoPI Status: Motorola General Business		