

PMSM Vector Control with Quadrature Encoder on Kinetis

Document Number: DRM128

Rev. 0, 1/2012

Contents

Section Number	Title	Page
Chapter 1		
Introduction		
1.1	Introduction	7
Chapter 2		
System Specification		
2.1	System specification.....	9
Chapter 3		
System Design		
3.1	Control theory.....	11
3.1.1	3-phase permanent magnet synchronous motor.....	11
3.1.2	Introduction to vector control.....	11
3.1.3	Vector control implementation.....	13
3.1.3.1	PI current controllers limitations.....	15
3.2	Hardware.....	17
3.2.1	Hardware set-up and configuration.....	17
Chapter 4		
Software Design		
4.1	Software design.....	21
4.2	Fractional numbers representation.....	21
4.3	Application overview.....	21
4.4	Kinetis K40 peripheral modules configuration.....	22
4.4.1	FlexTimer0 configuration for generating a 6-channel PWM.....	23
4.4.2	FlexTimer1 configuration for position detection using a quadrature encoder.....	24
4.4.3	ADC and PDB module configurations.....	25
4.4.4	ADC conversion timing, currents and voltage sampling.....	25
4.4.5	Current measurement.....	26
4.4.6	Periodic interrupt timer configuration.....	28
4.4.7	SPI configuration.....	29

Section Number	Title	Page
4.4.8	SCI (UART) configuration.....	29
4.5	Enabling the interrupts on the core level.....	30
4.6	FreeMASTER software.....	32
4.6.1	Introduction.....	32
4.6.2	FreeMASTER communication driver.....	32
4.6.3	FreeMASTER recorder and scope.....	33
4.7	Program flow.....	33
4.7.1	Application structure.....	33
4.7.2	Application background loop.....	34
4.7.3	Application state machine.....	35
4.7.3.1	States definition.....	36
4.7.3.2	Transitions definition.....	36
4.7.4	Interrupts.....	37
4.7.4.1	PIT channel 0 interrupt.....	37
4.7.4.2	ADC1 interrupt.....	38
4.7.4.3	PORTC interrupt.....	39
4.7.5	Project file structure.....	40
4.7.6	Memory usage.....	41

Chapter 5 Application Setup and Operation

5.1	Application set-up and operation	43
-----	--	----

Chapter 6 Measurement Results

6.1	CPU load and the execution time.....	45
6.2	Measurement results using FreeMASTER.....	45
6.2.1	3-phase current reconstruction.....	45
6.2.2	Speed controller.....	46

Chapter 7 References

7.1	References.....	49
-----	-----------------	----



Section Number	Title	Page
7.2 Acronyms and Abbreviations.....		50

Chapter 1

Introduction

1.1 Introduction

This design reference manual describes the design of a 3-phase permanent magnet synchronous motor (PMSM) vector control drive with quadrature encoder as a position and a speed sensor. The application runs on the Kinetis K40 ARM Cortex-M4 microcontroller. The document briefly describes the theory of the PMSM vector control and the hardware solution used. It is focused more on the application implementation on the Kinetis K40 microcontroller. Although the paper describes implementation on the Kinetis K40, the application can successfully run on any of the microcontrollers from the Kinetis family.

Application features

- Vector control of a permanent magnet synchronous motor using the quadrature encoder as a position sensor
- Targeted at the Tower rapid prototyping system (K40 tower board, Tower 3-phase low voltage power stage)
- Vector control with a speed closed-loop
- Rotation in both directions
- Application speed ranges from 0% to 100% of nominal speed (no field weakening)
- Operation via user buttons on the Kinetis K40 tower board or via FreeMASTER software

Solution Benefits

Kinetis is a mixed-signal MCU family based on the new ARM Cortex-M4 core and the most scalable portfolio of mixed-signal ARM Cortex-M4 MCUs in the industry. Five performance options are available from 50 to 150 MHz with flash memory ranging from 32 KB to 1 MB, and high RAM-to-flash ratios throughout. Common peripherals, memory maps and packages both within and across the MCU families allow for easy migration to

Introduction

greater or less memory and functionality. A vector control algorithm, demonstrated in this application enables PM Synchronous Motor control with excellent dynamic performance.

Chapter 2

System Specification

2.1 System specification

The system solution is designed to drive a 3-phase PM synchronous motor. The application meets the following performance specification:

- Application is targeted at the MK40x256 Kinetis ARM Cortex-M4 microcontroller
- Freescale's Tower rapid prototyping system is used as the hardware platform
- The control technique incorporates:
 - Vector control of a three-phase PM synchronous motor with quadrature encoder
 - Closed-loop speed control
 - Bi-directional rotation
 - Close-loop current control
 - Flux and torque independent control
 - Starting up with alignment
 - Field weakening is not implemented
 - Reconstruction of three-phase motor currents from two measured values
 - 63 μ s sampling period on the MK40 with the FreeMASTER recorder
- Works with the FreeMASTER software interface for application control and monitoring:
 - Required speed setting, start/stop status, motor current, system status, faults acknowledgment
 - Includes FreeMASTER software speed scope (observes actual and desired speeds)
 - Includes FreeMASTER software high-speed recorder (reconstructed motor currents, voltages)
 - Application includes overcurrent protection, different faults latched by the MOSFET driver, and a motor phase disconnection.
- User buttons for manual control



Chapter 3 System Design

3.1 Control theory

3.1.1 3-phase permanent magnet synchronous motor

The construction of the PM synchronous motor and its mathematical description using a space model can be found in the designer reference manual *PM Sinusoidal Motor Vector Control with Quadrature Encoder* (document DRM105 [3]).

3.1.2 Introduction to vector control

The permanent magnet synchronous motor features (high efficiency, high torque capability, high power density and durability) are good for using the PMSM in motion-control applications. The key idea for the vector control algorithm of the AC motors was to achieve an AC motor torque/speed characteristic similar to that of the separately excited DC motor. In the DC motor, the maximum torque is generated automatically by the mechanical switch called the commutator. The commutator feeds current only to that coil whose position is orthogonal to the direction of the magnetic flux generated by the stator permanent magnets or excitation coils. The PMSM has the inverse construction, the excitation is on the rotor and the motor has no commutator. It is possible to control these two components independently and to reach the required performance, thanks to the decomposition of the stator current into a magnetic field-generating part and a torque-generating part. To keep the constant desired torque, the magnetic field generated by the stator coils has to follow the rotor at the same synchronous speed. Therefore, to successfully perform the vector control, the rotor shaft position must be known and is one of the key variables in the vector control algorithm. For this purpose, either the mechanical position sensors are used (encoders, resolvers and so on) or the position of the shaft is calculated (estimated) from the motor phase currents and voltage. This is then called sensorless control. Using the mechanical position, sensors bring several benefits. The position is known over the entire speed range with the same precision, there is no

need to compute highly mathematically intensive algorithms that estimate the rotor shaft position. So vector control with a position sensor can be implemented on less powerful microcontrollers. The performance of the MCU can also be used for other tasks. On the other hand, the cost of the mechanical sensor is a significant portion of the cost of the whole drive.

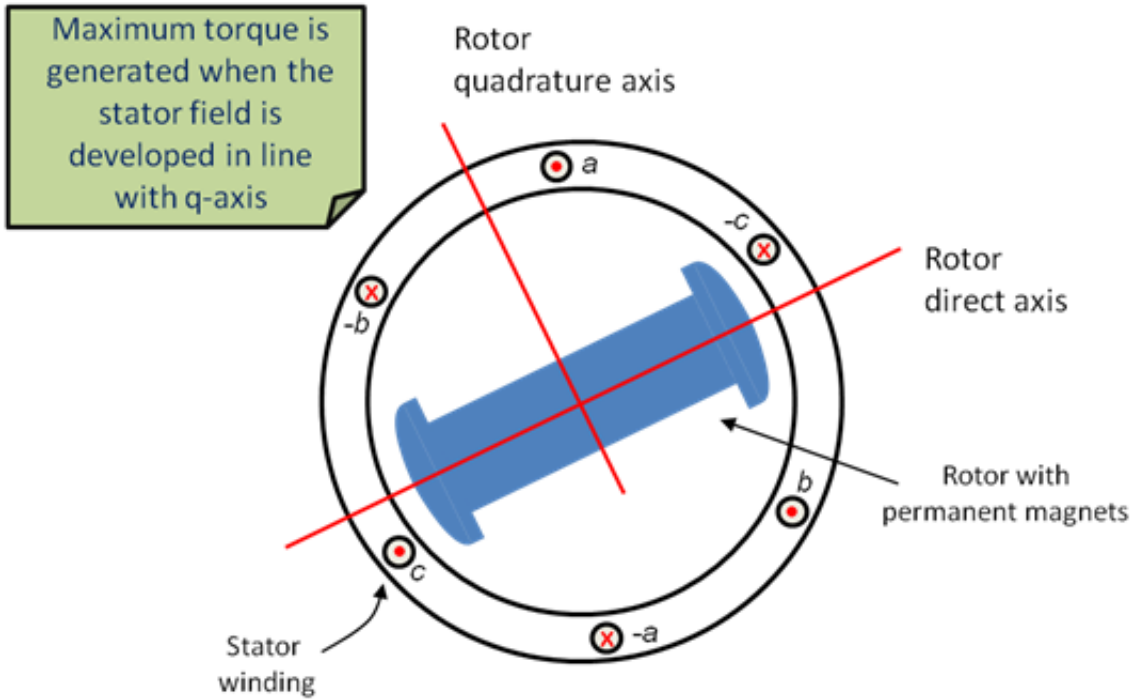

Figure 3-1. Synchronous machine and the main principle of the vector control

As mentioned, the required torque is proportional to the q-portion of the orthogonal d,q-currents system. The d-portion reflects the generation of the rotor magnetic flux. Because there are permanent magnets mounted on the PMSM rotor, this current is usually kept at a zero level, unless the field weakening is performed to accelerate the motor above the nominal speed or while performing the MTPA algorithm. In such cases, the required d-current possesses a negative value.

Therefore, the control process (regulation) is focused on maintaining the desired values of the d and q currents.

Because the d,q system is referenced to the rotor, the measured stator currents have to be transformed from the 3-phase a,b,c stationary frame into the 2-phase d,q rotary frame before they enter the regulator block. At first, the Clarke transformation is calculated, which transforms the quantities from the 3-phase to 2-phase systems. Because the space vector is defined in the plane (2D), it is sufficient to describe it in the 2-axis (alpha, beta) coordinate system. Consequently, the result of the transformation into the 2-phase

synchronous frame (Park transformation) is two DC values – the d,q currents. It is much easier to regulate two DC variables than two variables changing in time. The following picture shows the transformation sequencing.

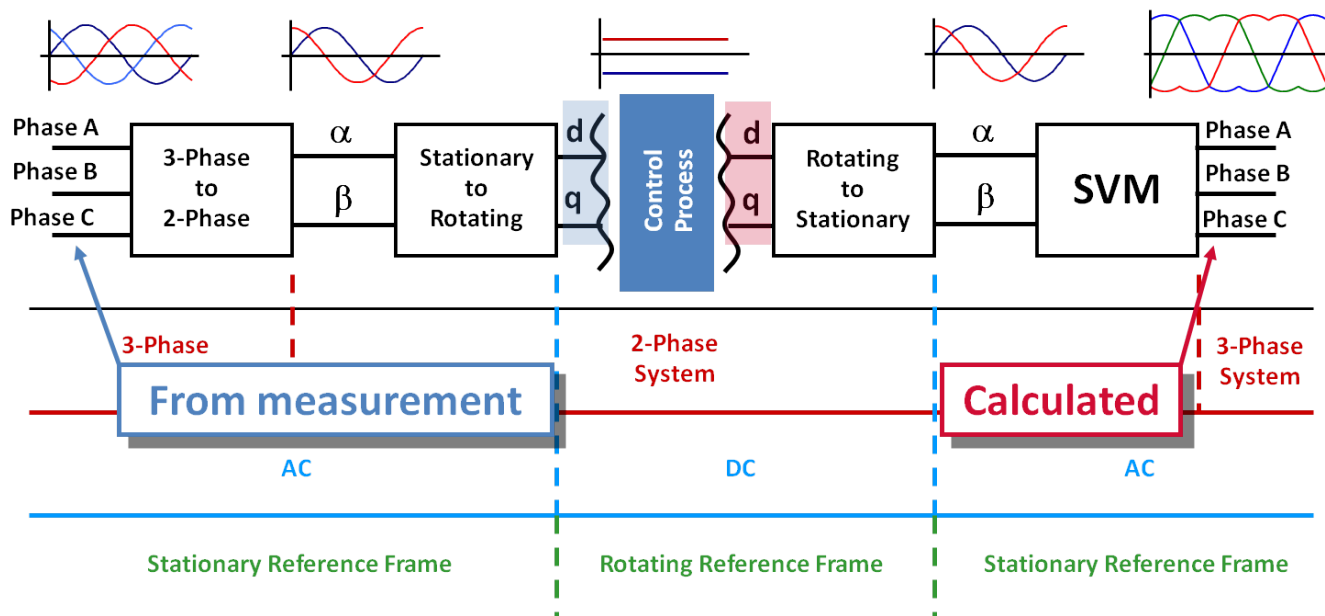

Figure 3-2. Transformation sequencing

3.1.3 Vector control implementation

There is an enhancement to the vector control algorithm implemented in the application described in the designer reference manual *PM Sinusoidal Motor Vector Control with Quadrature Encoder* (document DRM105 [3]). The limitations of the PI current controllers are calculated in real time based on the available DC-bus voltage.

Figure 3-3 is a simplified block diagram of the vector control algorithm. The aim of this control is to regulate the motor speed at a predefined level. The speed command value is set by a high level control. The algorithm is executed in two control loops. The fast inner control loop is executed within a hundred μsec period. The slow outer control loop is executed within a period of an msec.

The fast control loop executes two independent current control loops. They are the direct and quadrature-axis current (i_{sd} , i_{sq}) PI controllers. The direct-axis current is used to control the rotor magnetizing flux. The quadrature-axis current corresponds to the motor torque. The current PI controllers' outputs are summed with the corresponding d and q axis components of the decoupling stator voltage. Thus, the desired space vector for the

stator voltage is obtained and then applied to the motor. The fast control loop executes all the necessary tasks to achieve an independent control of the stator current components. These include:

- Three-phase current reconstruction
- Forward Clarke transformation
- Forward and backward Park transformations
- Rotor magnetizing flux position evaluation
- DC-bus voltage ripple elimination
- Space vector modulation (SVM)

The slow control loop executes the speed controller, field weakening control and lower priority control tasks. The PI speed controller output sets a reference for the torque producing quadrature axis component of the stator current i_{q_ref} and the flux producing current i_{d_ref} .

To achieve the goal of the PM synchronous motor control, the algorithm uses feedback signals. The essential feedback signals are three-phase stator current and stator voltage. For correct operation, the presented control structure requires a speed feedback on the motor shaft. [5]

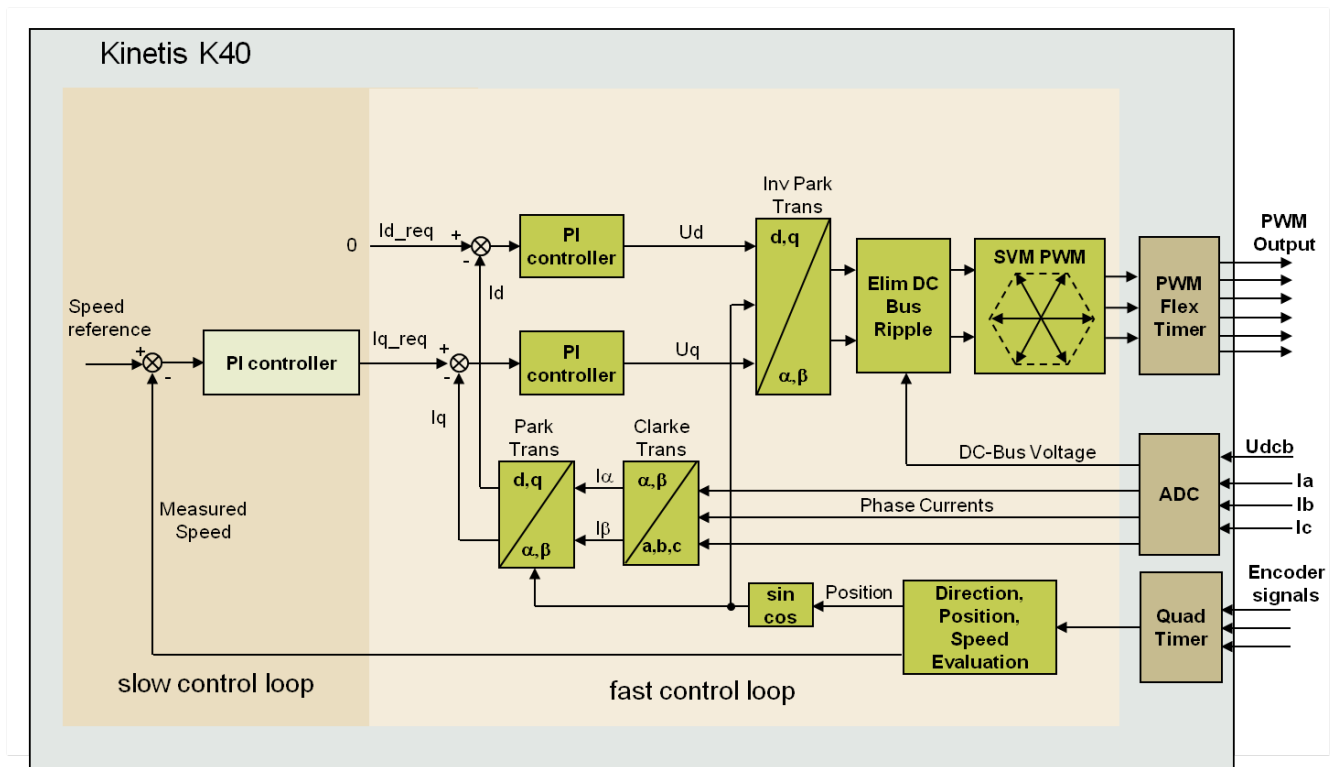

Figure 3-3. Simplified block diagram of PMSM vector control

In [Figure 3-3](#), the algorithm of the PMSM vector control is represented as a chain of functions. Outputs of one function serve as inputs to the other functions. Each body of the functions contain mathematical equations not involving the peripherals. To speed-up the development of any motor control applications, these motor control functions together with some commonly used mathematic algorithms, such as trigonometric functions, controllers, or limitations and digital filters, were placed into one set and create the Motor Control Library. The motor control libraries are available for some Freescale MCU platforms, optimized for each platform to maximize the use of available core features. The functions were tested and are well documented. Therefore, building the motor control application is much simpler for the developer.

3.1.3.1 PI current controllers limitations

As mentioned earlier, for a better motor dynamic performance the vector control algorithm is enhanced to a dynamic limitation of the d- and q- current PI controller outputs. The main reason is to require only the amount of voltage that is currently available on the DC-bus. This approach, together with use of an anti-windup strategy in the algorithm of the PI regulator, gives higher stability to the drive system during load variations rather than using only the circle limitation of the output voltage vector. The integrator inside the regulator algorithm stops when the power limitation occurs due to a step increase of the load, or a DC-bus voltage drop.

The figure below is a block diagram of the fast (current) control loop, including the computation of the current controller limitations.

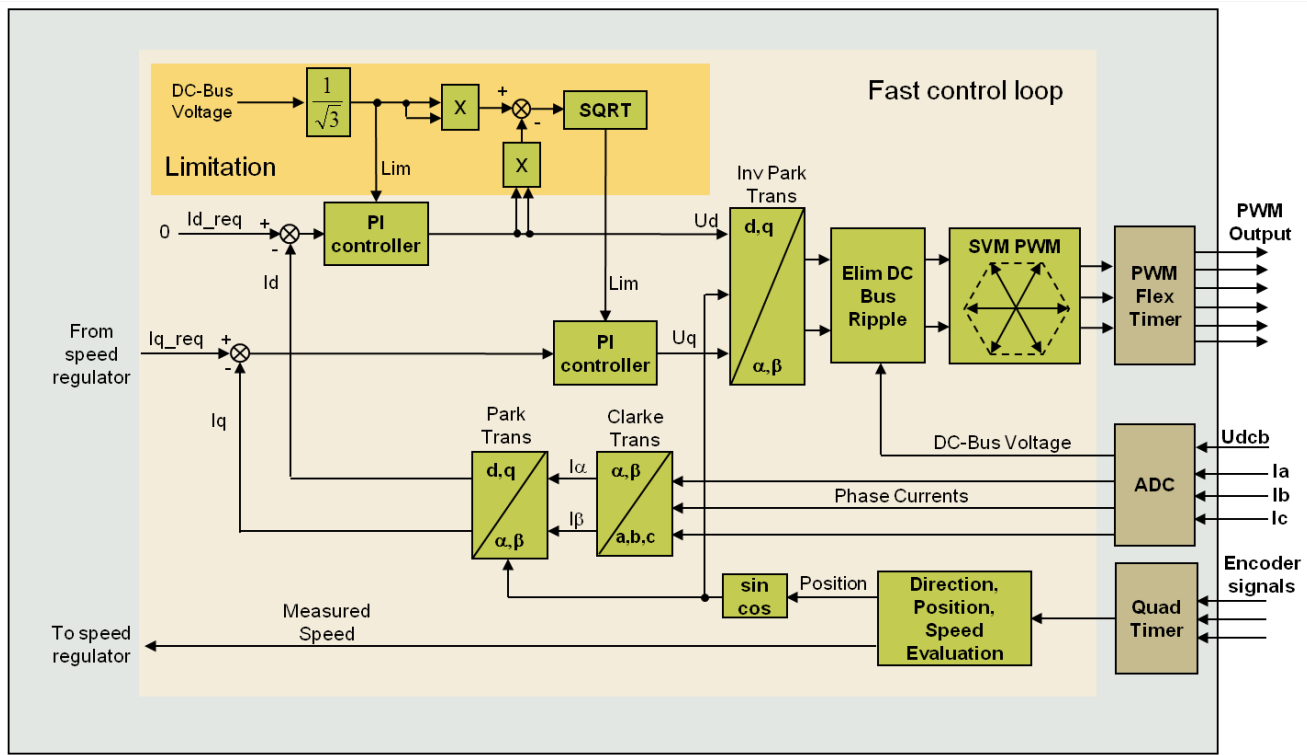

Figure 3-4. Block diagram of the fast control loop

The equations 3-1 and 3-2 show the mathematical expression of the controllers limitation.

Eqn. 3-1

$$U_{d_Lim} = \frac{U_{DCB}}{\sqrt{3}}$$

Eqn. 3-2

$$U_{q_Lim} = \sqrt{\left(\frac{U_{DCB}}{\sqrt{3}}\right)^2 - U_d^2}$$

Where: U_{d_Lim} , U_{q_Lim} are the limitations of the d- and q- current PI regulators respectively

U_{DCB} is the actual value of the DC-bus voltage

U_d is the output of the d-current PI controller

The parameters of the PI current regulators were tuned using the Ziegler-Nichols method. After the motor alignment in the d-axis, the rotor has stopped and according to the step response the parameters of the d-current PI regulator were tuned. The same parameters were used also for the q-current PI regulator, because of the difference in values of the motor inductances L_d , L_q is not significant.

3.2 Hardware

The hardware solution of the PMSM Vector Control with Encoder on Kinetis is built on the Freescale's Tower rapid prototyping system. It consists of the following modules:

- Tower elevator modules (TWR-ELEV)
- Kinetis K40 tower module (TWR-K40X256)
- 3-phase low voltage power module (TWR-MC-LV3PH)
- Tower Serial Module (TWR-SER)

All modules of the Tower system are available to order via the Freescale web page or from distributors. The user can easily build the hardware platform for which the application is targeted.

3.2.1 Hardware set-up and configuration

Building the system using the modules of the Tower system is not difficult. The peripheral modules and the MCU module are plugged into the elevator connectors, while the white stripe on the side of the module boards determines the orientation to the Functional elevator (the elevator with the mini USB connector, power supplies, and the switch); see the following Figure 3-5.

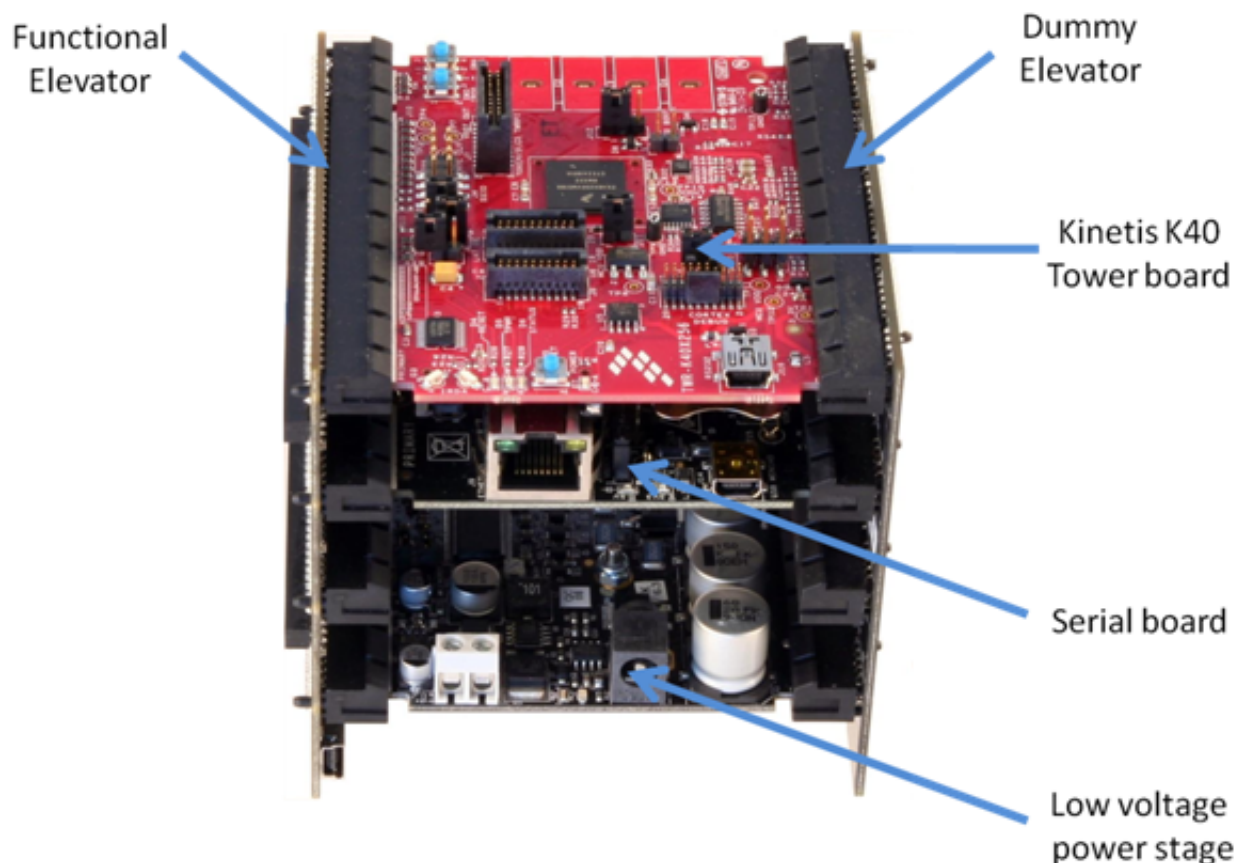

Figure 3-5. Hardware built on the modules of the Tower system

It is recommended to place the MCU board on the top of the Tower system, this way the user’s buttons are easily accessible.

It is necessary to configure the Tower 3-phase low-voltage power stage. The jumper settings are listed in the following table and the jumper positions are highlighted in Figure 3-6. See also the user’s manual [12] for more details (for example, hardware overcurrent threshold setting) of the Tower low voltage power stage.

Table 3-1. Jumper settings of TWR-MC-LV3PH board

Jumper #		Setting	Note
J2	VDDA Source Select	1-2	Internal analog power supply
J3	VSSA Source Select	1-2	Internal analog power supply
J10	AN6 Signal Select	1-2	Phase C current signal
J11	AN5 Signal Select	1-2	Phase B current signal
J12	AN2 Signal Select	1-2	Phase A current signal

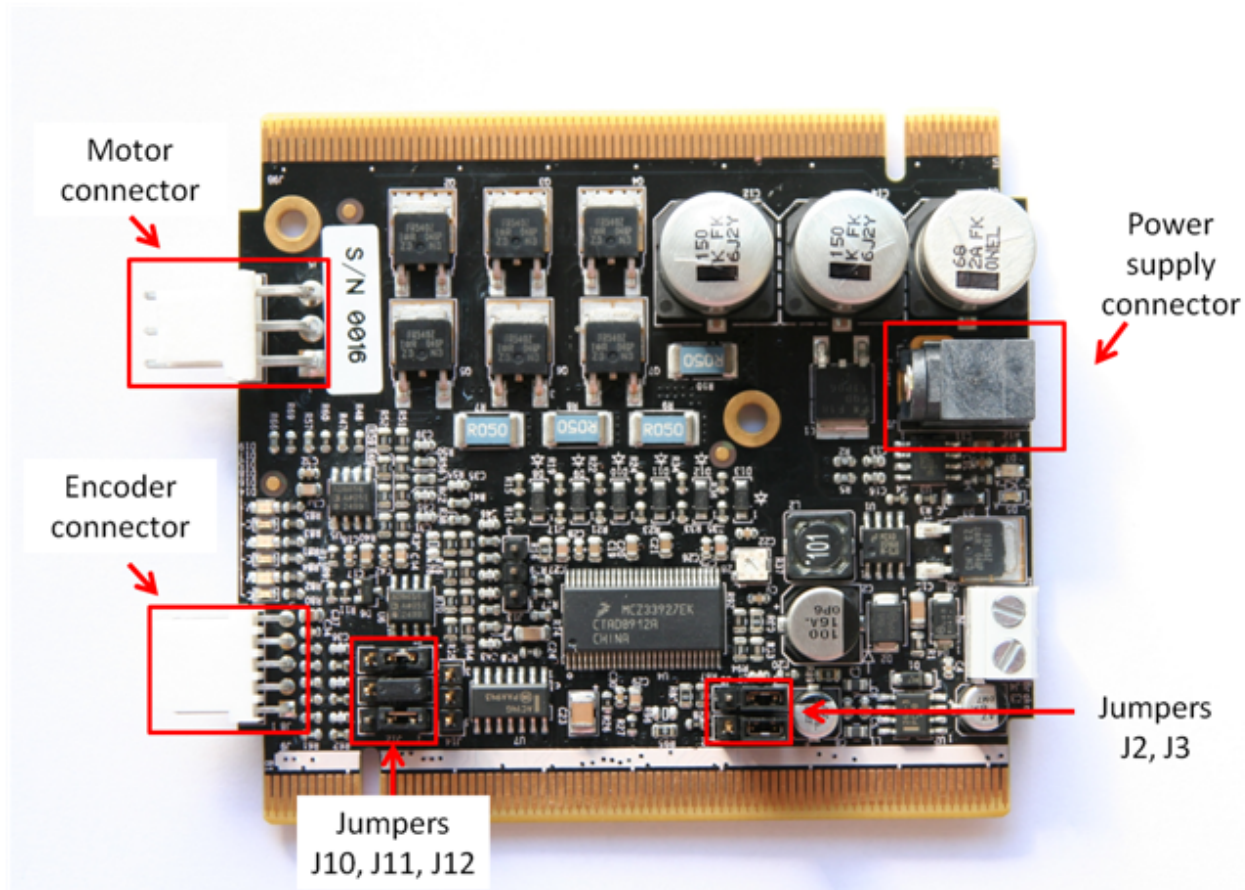

Figure 3-6. Jumpers and connectors positions on the TWR-MC-LV3PH

Table 3-2 shows the signal assignment of the motor and encoder connectors of the TWR-MC-LV3PH. Because the FlexTimer module on the Kinetis K40 does not support the index signal, this can be left disconnected.

Table 3-2. Motor and encoder connectors on the TWR-MC-LV3PH

Connector	Pin#	Description
Motor connector J5	1	Motor phase A
	2	Motor phase B
	3	Motor phase C
Encoder connector J8	1	5 V DC
	2	GND
	3	Encoder phase A
	4	Encoder phase B
	5	Encoder index

CAUTION

For Revision “B” of the TWR-MC-LV3PH — Do not plug any other cables into the Tower system except for the power supply cable and serial communication cable. Do not connect any USB cable to the Tower system while the power is applied to the power stage module TWR-MC-LV3PH. The demo system can be powered only via the Tower Low Voltage Power Stage. Connecting a USB cable to the Tower Elevator Module can cause damage to the Kinetis K40. See Errata for the revision “B” of the TWR-MC-LV3PH on how to correctly operate the board.

The motor used in the reference design is a standard production industrial 3-phase PM synchronous motor with an incremental encoder mounted on the shaft. The motor and the sensor have the following specifications:

Table 3-3. Specification of the motor and incremental sensor

	Manufacturer name	TG Drives
Motor Specification	Type	TGT2-0032-30-24/T0PS1KX-1M
	Nominal Voltage (line-to-line)	18V
	Nominal Speed	3000 rpm
	Nominal Current (phase)	5.20 A
	Nominal Torque	0.30 Nm
Motor Model Parameters	Stator Winding Resistance (line-to-line)	0.576 Ohm
	Stator Winding Inductance d axis	0.468 mH
	Stator Winding Inductance q axis	0.618 mH
	Number of Pole-Pairs	3
Position Sensor Specification	Manufacturer name:	INDUcoder
	Type:	ES 28-6-1024-05-D-R
	Pulse Count per revolution	1024
	Output	5 V±10 % TTL

Chapter 4 Software Design

4.1 Software design

The application software was designed using the compiler IAR Embedded Workbench for ARM v. 6.21

4.2 Fractional numbers representation

In the development of the vector control algorithm software libraries were used (a Set of the General Maths and Motor Control Functions for the Cortex M4 Core). Most of the mathematical calculations were performed with the numbers represented in Q1.15 or Q1.31 signed fractional format, so all physical quantities were scaled to the $[-1,1)$ interval. For more on the fractional format and variables scaling, see DRM105 [3].

4.3 Application overview

The application is real-time interrupt-driven with the background infinite loop handling the application states (Initialization, Run, Fault,...) and FreeMASTER communication polling.

There are two periodic interrupt service routines where the control process is executed. Their timing is given by the requirements of the vector control algorithm.

The control process is composed of two control loops. Execution of the fast (current) control loop is performed in the ADC1 interrupt service routine, which is executed after the values of the sampled DC bus voltage and motor phase currents are put into the ADC result registers. The sampling instance is precisely defined by the hardware trigger of FlexTimer0 that is configured to generate six PWM signals of frequency 16 kHz.

The PIT0 interrupt service routine is triggered every one millisecond. In this ISR, the speed is calculated as a position derivation and the speed controller (slow speed control loop) is calculated.

The individual processes of the control routines are described in the following sections.

4.4 Kinetis K40 peripheral modules configuration

In this section, peripherals configuration procedures used are described or referenced. On all Kinetis family devices, it is necessary to enable the system clock for the module before any access to the peripheral registers is performed. The modules are enabled by writing “1” to the particular bit in the System Clock Gate Control Register. Any write or read attempt to the peripheral register before enabling the clock for a particular peripheral module will yield a hard fault. Refer to [1] for a detailed description of each peripheral module.

Table 4-1 shows an overview of the Kinetis K40 peripheral modules used by the application, the number of modules and module channels reflect a 144-pin package.

Table 4-1. Kinetis K40 peripherals overview

Kinetis K40 peripherals			Used in the application	Purpose
Group	Module	Number of modules or channels		
Analog	ADC	2 modules, both 23 channels single ended and 3 differential pairs	3 channels on ADC0 2 channels on ADC1	DC-bus voltage and motor phase currents sensing
	Comparators	3	—	
	DAC	2	—	
Communications	SPI	3	1	MOSFET driver configuration
	UART	6	1	FreeMASTER communication
	CAN	2	—	
	USB	1	—	
	I2C	2	—	
	SDHC	1	—	
	I2S	1	—	

Table continues on the next page...

Table 4-1. Kinetis K40 peripherals overview (continued)

Timers	FlexTimer	8 ch	6 ch	Generation 6-ch PWM for motor control
		2 ch	2 ch	Quadrature encoder signals decoding
		2 ch	—	
	PIT	4	1	1 ms time base for speed calculation
	PDB	2 ch for ADC triggering	2	DC-bus voltage and phase current sampling initiation
		2 ch for DAC triggering	—	
	LPT	1	—	
	CMT	1	—	
RTC	1	—		

4.4.1 FlexTimer0 configuration for generating a 6-channel PWM

The FlexTimer Module (FTM) is a two to eight channel timer that supports input capture, output compare, and the generation of PWM signals to control an electric motor and power management applications. The FTM time reference is a 16-bit counter that can be used as an unsigned or signed counter. On the Kinetis K40 there are three instances of FTM. One FTM has 8 channels, the other two FTMs have 2 channels.

The procedure of the FlexTimer configuration for generating a center-aligned PWM with dead time insertion is described in the application note titled *Using FlexTimer in ACIM/ PMSM Motor Control Applications* (document AN3729 [6]).

Because the referenced application note supports an earlier version (1.0) of the FlexTimer implemented on the ColdFire V1, and with respect to the hardware used (TWR-MC-LV3PH), there are a few differences in the configuration, as described below:

- At first, it is necessary to enable the system clock for the FlexTimer module in the Clock Gating Control Register:

```
SIM_SCGC6 |= SIM_SCGC6_FTM0_MASK;
```

- It is necessary to disable the write protection of some registers before they can be updated:

```
FTM0_MODE |= FTM0_MODE_WPDIS_MASK;
```

- Then it is advisable to enable the internal FlexTimer counter to run in the debug mode:

```
FTM0_CONF |= FTM_CONF_BDMMODE(3);
```

While the HW debugging interface (jLink, Multilink,...) is connected to the microcontroller, the MCU is in debug mode. This does not depend on the running code containing breakpoints or not.

- The PWM signals generated by the FlexTimer0 are directly connected to the MOSFET driver. Due to safety reasons, the input signals for the top transistors on the MOSFET driver used on the Tower low voltage power stage have inversed polarity. Therefore, it is also necessary to set the right polarity of the PWM signals:

```
FTM0_POL = FTM_POL_POL0_MASK |
            FTM_POL_POL2_MASK |
            FTM_POL_POL4_MASK;
```

- The duty cycle is changed by changing the value of the FlexTimer Value registers. These registers are double-buffered, meaning that their values are updated not only by writing the number, but it is necessary to confirm the change by setting the Load Enable (LDOK) bit. This ensures that all values are updated at the same instance:

```
FTM0_PWMLOAD = FTM_PWMLOAD_LDOK_MASK;
```

It is necessary to write the LDOK bit every time the value registers are changed, so not only at the stage of loading them with initial values, but with every update after the duty cycle value is computed in the vector control algorithm.

- As mentioned in section 4.3.4, in this application, hardware triggering of the A/D converter is employed. The Initialization Trigger signal from the FlexTimer is used as the primary triggering signal, which is fed into the Programmable Delay Block that services the timing of the AD conversion initiation.

```
FTM0_EXTTRIG |= FTM_EXTTRIG_INITTRIGEN_MASK;
```

- Finally, the output pins of the MCU have to be configured to bring the signals out of the chip. The assignment of signals to output pins is set in the Pin Control Register, while the available signals are listed in the Signal Multiplexing chapter of [1] and are package dependent.

```
PORTC_PCR1 = PORT_PCR_MUX(4); // FTM0 CH0
PORTC_PCR2 = PORT_PCR_MUX(4); // FTM0 CH1
PORTC_PCR3 = PORT_PCR_MUX(4); // FTM0 CH2
PORTC_PCR4 = PORT_PCR_MUX(4); // FTM0 CH3
PORTD_PCR4 = PORT_PCR_MUX(4); // FTM0 CH4
PORTD_PCR5 = PORT_PCR_MUX(4); // FTM0 CH5
```

The port settings implemented in the application code of course reflect the hardware solution built on the Tower system modules.

4.4.2 FlexTimer1 configuration for position detection using a quadrature encoder

FlexTimer1 is used in the application to decode the quadrature encoder signals. A detailed procedure on configuring the FTM for this operation as well as the principle of position and speed detection using a quadrature encoder is described in the application note titled *Configuring the FlexTimer for Position and Speed Measurement with an Encoder* (document number AN4381 [7]).

4.4.3 ADC and PDB module configurations

The on-chip ADC module is used to sample feedback signals (motor phase current and DC bus voltage) that are necessary to successfully perform the vector control algorithm. The Programmable Delay Block closely cooperates with the ADC and serves for hardware triggering of the sampling.

It is required to perform a self-calibrating procedure of the ADC module before it is used in the application to obtain a specified accuracy. The calibration process also requires a programmer's intervention to generate the plus-side and minus-side gain calibration results and store them in the ADC plus-side gain and minus-side gain registers after the calibration function completes. The calibration has to be performed for both ADC modules. After calibration, the ADC modules are configured to a 12-bit accuracy. The input clock of the ADC module is limited to 18 MHz according to the Kinetis K40 Datasheet [10]. The CPU frequency is set to 100 MHz, therefore by using an available prescaler value the input clock to the ADC module is set to 12.5 MHz. That setting yields a conversion time of 2.2 μ s. Finally, the hardware trigger has to be enabled in the Status and Control Register 2.

The Programmable Delay Block (PDB) provides controllable delays from either an internal or an external trigger, or a programmable interval tick to the ADCs hardware trigger inputs, so a precise timing between ADC conversions is achieved. The PDB module has an internal counter that overflows on a modulo value. Because the input trigger comes periodically from the FTM0, the input clock source and the modulo value is set identically as for the FTM0 module. The values in the channel delay registers are set to generate triggers to start sampling the DC-bus voltage and the motor phase AD conversions. The PDB module on the K40 MCU allows 15 for different input trigger sources. They are listed in the chapter "Chip configuration" in the section "PDB Configuration" in [1]. Similarly in FTM0, the LDOK bit has to be set to acknowledge the changes in the modulo and the delay registers.

4.4.4 ADC conversion timing, currents and voltage sampling

The FlexTimer0 is configured to trigger an internal hardware signal when its counter is reset after overflow to the initialization value. This signal is fed into the Programmable Delay Block (PDB) that consequently triggers the AD conversion of the voltage and currents with a predefined delay. On the Kinetis K40 MCU, two ADC modules are implemented. Each ADC module associates to one channel of the PDB module. Each ADC module has two result registers (two channels), and they correspond to two programmable pre-trigger delays of the PDB channels. It is possible to perform four AD conversions without requesting an interrupt (respecting that the DMA is not used for data transfer). In this application, only three conversions need to be triggered without CPU intervention (two motor phase currents and the DC-Bus voltage). The following time diagram shows the modules interconnection and the ADC interrupt generation.

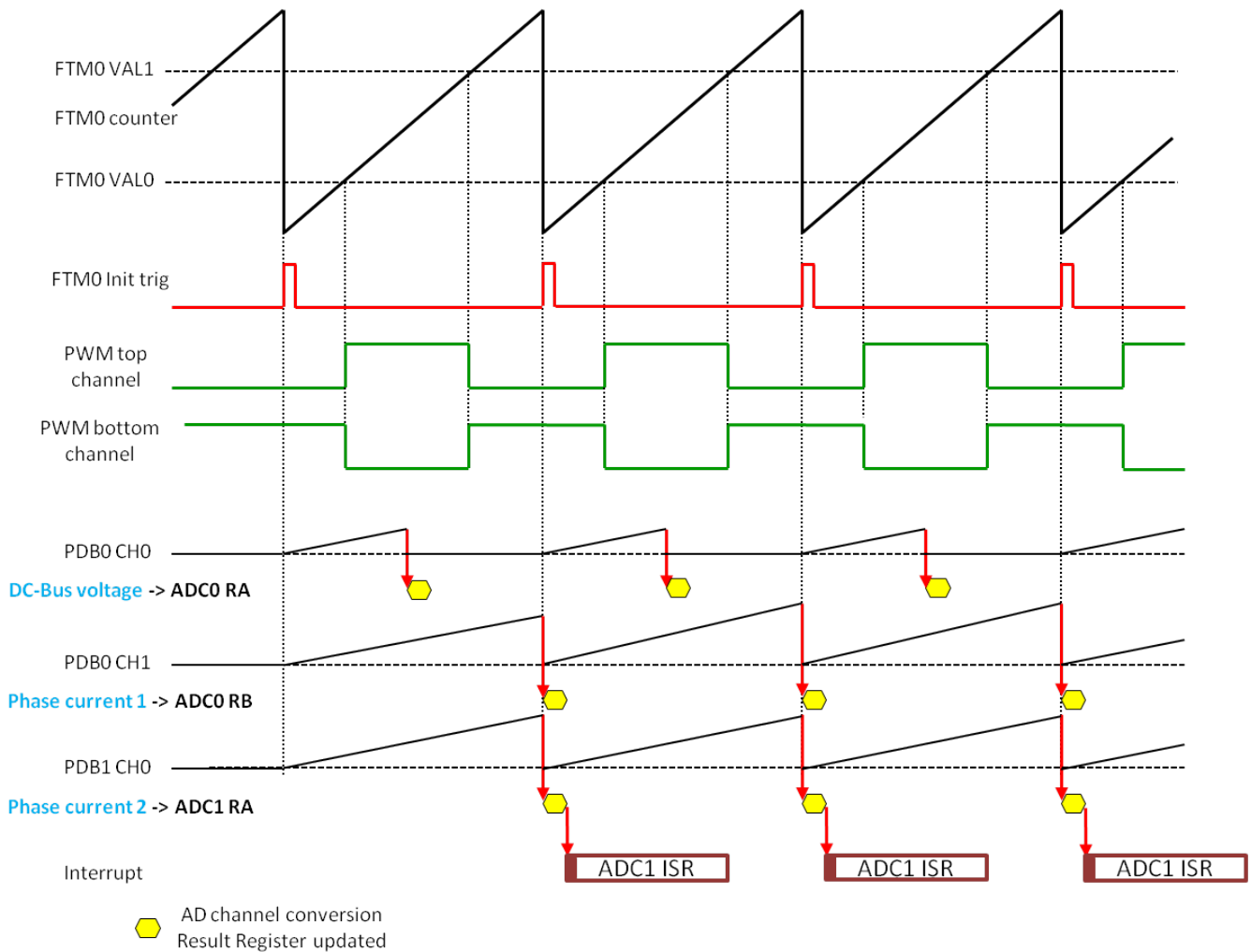

Figure 4-1. ADC conversion timing

4.4.5 Current measurement

Closely related to the ADC conversion trigger timing is the assignment of the ADC channels to the measured analog signals. For computation of the fast (current) control loop of the FOC, it is necessary to know the values of all three motor phase currents. Because there are only two ADC modules, it is possible to sample only two analog quantities in one instance. Assuming the motor represents a symmetrical 3-phase system, the sum of all three instantaneous phase currents is zero.

Eqn. 4-1

$$0 = i_A + i_B + i_C$$

Because the phase currents are measured at the moment the bottom transistors are conducting, in the case of high duty cycle ratios (current value is in the maximum area of the sine curve), the time when the current can be measured is too short. The bottom transistor must be switched on at least for a critical pulse width to get a stabilized current shunt resistor voltage drop. The selection of the channels is done based on the section where the space vector of the stator current is generated. This assignment is performed at the end of the ADC1 interrupt service routine. Therefore, it is enough to sample only two phase currents while the third is easily calculated according to eq. 4.2

Eqn. 4-2

Sector 1,6: $i_A = -i_B - i_C$

Sector 2,3: $i_B = -i_A - i_C$

Sector 4,5: $i_C = -i_B - i_A$

The following figure explains, in two cases (case I at 60°, case II at 30°) why the calculation of the third current is necessary.

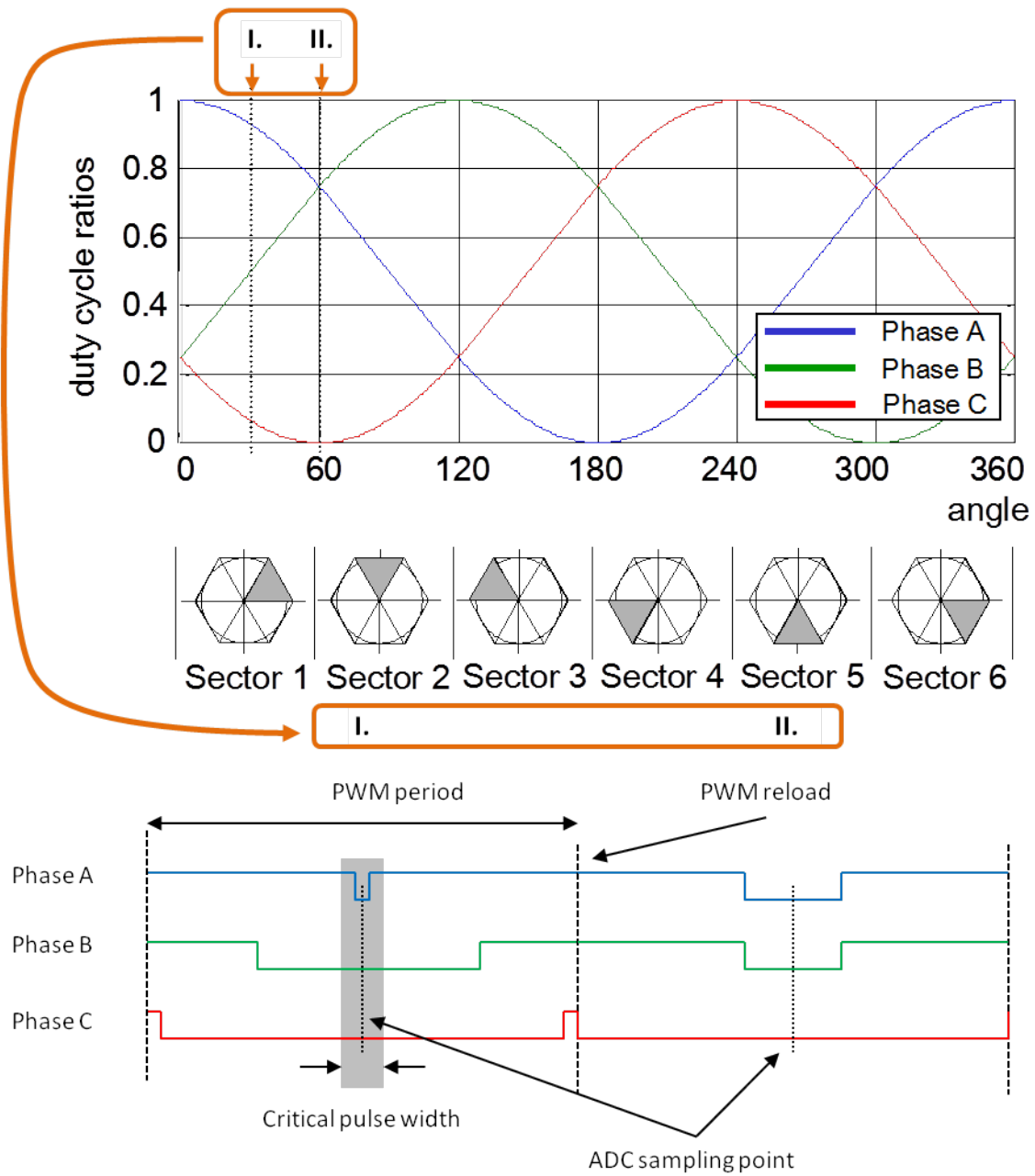

Figure 4-2. Current sensing

At 60° all three currents can be sampled, the currents are sampled when the bottom transistors are turned-on. The pulse width is sufficient to stabilize the current and to perform the acquisition of the signal value by the AD converter. At 30°, the pulse is too short, so the current of Phase A cannot be sampled.

4.4.6 Periodic interrupt timer configuration

The PIT serves to generate a 1 ms time base for the slow (speed) control loop. There is one PIT module with four channels implemented on the K40 MCU. The timer module has an internal 32-bit counter clocked from the system clock. It possesses no prescalers. The number of the value registers reflects the number of channels. The timer generates a trigger at periodic intervals when enabled. It loads its start value as specified in the LDVAL register, then counts down until it reaches 0. It then loads its respective start value again. Each time the timer reaches 0, it will generate a trigger pulse and set the interrupt flag. The initialization is short and is performed in four steps:

- Enabling the clock for the module in the particular System Clock Gating Control Register,
- Enabling the internal module timer in the PIT Module Control Register,
- Writing the load value into the LDVAL Register
- Enabling the interrupt

Due to a bug on the chip mask 0M33Z (see Errata [14]), there has to be a certain software workaround performed in the PIT interrupt service routine to allow generation of the next interrupt:

1. Disable the interrupt first by clearing the TIE bit (while the TEN bit remained unchanged):

```
PIT_TCTRL0 = 0x01;
```

2. Clear the interrupt flag:

```
PIT_TFLG0 = 0x01;
```

3. Enable the PIT interrupt again:

```
PIT_TCTRL0 = 0x03;
```

4.4.7 SPI configuration

The SPI interface is used in the application for communication between the intelligent MOSFET driver MC33937 and the K40 MCU. The MC33937 driver is placed on the Tower low voltage power module and serves for driving the high-side and low-side MOSFET transistors of the 3-phase inverter. In the application, the initialization of the MC33937 has to be performed, mainly in setting the dead time. During the motor run there is also periodic checking of the status register of the driver (in the PIT interrupt), to provide information on the latched faults. The MC33937 driver requires precise timing of the SPI signals. The default MCU setting is not possible to use. The exact timing of the SPI signals is listed in [8].

4.4.8 SCI (UART) configuration

The SCI is used in the application for the communication between the master system and the embedded application. A master system is the notebook or the PC where the FreeMASTER software is installed to control the application and visualization of its state. On the Kinetis K40, there are six UART modules implemented. Due to the hardware solution based on the Tower modules, the UART3 is used. The communication speed is set to 56000 Bd, and in fact, it is limited by the USB-to-Serial Cable used. The module configuration is performed in the FreeMASTER software driver included in the project.

4.5 Enabling the interrupts on the core level

The interrupt request enabled on the peripheral module has to be enabled also on the core level, otherwise the interrupt request will not be generated. The process is not straightforward and the necessary information is spread over several documents. To help the user to enable any interrupt while enhancing the application to other features, the process of setting-up the PIT interrupt is described in this section as an example.

The interrupt request on the module level is enabled by writing “1” to the TIE bit of the Timer Control Register:

```
PIT_TCTRL0 |= PIT_TCTRL_TIE_MASK;
```

It is necessary to find the number of the interrupt and the IRQ vector. Both values can be found in the *K40 Sub-Family Reference Manual* [1] in the section 3.2.2.3 “Interrupt channel assignments”. For the PIT channel 1 interrupt, the interrupt vector is 84 and the interrupt number is 68. This is always 16 less than the vector number, because the first 16 interrupt vectors are ARM core system handler exception vectors.

The next step is to redefine the vector pointer in the “vectors.h” file from the default ISR to the function that contains the code to be executed after an interrupt is generated.

Replace

```
#define VECTOR_084 default_isr
```

with

```
#define VECTOR_084 PIT_CH0_ISR_Handler
```

and add at the end of the file:

```
extern void PIT_CH0_ISR_Handler(void);
```

because the ISR is defined in the other file (“main.c” in this case).

Next, set-up the ARM core NVIC register. Each interrupt vector must be independently enabled or disabled by setting the corresponding bit in the complementary pair of registers, the Interrupt Set-Enable Register (NVIC_ISERx) or the Interrupt Clear-Enable Register (NVIC_ICERx). NVIC_ISER0 contains the enable bits for IRQ numbers 0 through 31, NVIC_ISER1 contains the enable bits for IRQ 32 through 63, and so on. To enable the PIT channel 0 interrupt (interrupt number 68), it is necessary to write 0x00000010 (b10000) to the NVIC_ISER2 register.

It is an advisable approach to clear any pending interrupt before it is enabled. This is usually not necessary to do right after the reset when the MCU initialization is performed, but during the program execution when a certain interrupt is disabled and later re-enabled again. If an interrupt flag has been set before the interrupt was enabled, the interrupt controller may generate an unhandled exception fault if the interrupt flag has not been cleared before:

```
NVICICPR2 = 0x00000010; // clear pending interrupts first
NVICISER2 = 0x00000010; // enable the PIT CH0 interrupt
```

NOTE

The ARM document [9] indicates that the registers have an underscore between NVIC and ISER (NVIC_ISER1). However, in the current header files used in the application, the NVIC register names do not have the underscore (NVICISER1 or NVICICPR1).

NVIC interrupts are prioritized by updating an 8-bit field within the 32-bit NVIC_IPRx registers. Thanks to macros contained in the Kinetis K40 header file used in the project, setting the priority of the interrupt has been simplified. The number of the interrupt is used as one of the parameters of the NVIC_IP macro. The assigned value then determines the priority (the higher the number, the higher the priority of the interrupt). If the interrupt priority is not specified, the lower the number of the interrupt vector, the higher priority the interrupt has by default. On the Kinetis family there are 16 levels of interrupt priority implemented. However, the priority is set in the four MSBs of the 8-bit field:

```
NVIC_IP(68) = 0xF0; //set the highest priority for PIT ch. 0 interrupt.
```

The next step is to enable the interrupts globally by clearing a 1-bit special-purpose mask register PRIMASK. The PRIMASK is cleared to 0 by the execution of the instruction CPSIE i :

In the application this is defined as the macro:

```
#define EnableInterrupts asm(" CPSIE i ");
```

Finally, the interrupt service routine has to be defined “PIT_CH0_ISR_Handler” and inside the body of the function, the source of the interrupt must be cleared to leave the interrupt service routine. For the PIT channel 0 interrupt, this means that the interrupt flag is cleared by writing “1” to the TIF bit of the Timer Flag Register:

```
PIT_TFLG0 = PIT_TFLG_TIF_MASK;
```

4.6 FreeMASTER software

4.6.1 Introduction

The FreeMASTER software was designed to provide a debugging, diagnostic, and demonstrational tool for the development of algorithms and applications. Moreover, it is useful for tuning the application for different power stages and motors, because almost all of the application parameters can be changed via the FreeMASTER interface. This consists of a component running on a PC and another part running on the target controller. Nowadays, different communication interfaces are supported (RS-232, USB, Ethernet, OSBDM,...) and the work on improvements and support for new families of microcontrollers is still in progress.

In the application the RS232 interface is used, because it represents minimal communication overhead that has to be handled by the MCU and requires no interrupts (working in polling mode), which is important for motor control applications. A detailed users guide of FreeMASTER, with useful hints for developing a motor control application, can be found in the application note titled *Real Time Development of MC Applications using the PC Master Software Visualization Tool* *document (AN1948 [11]).

4.6.2 FreeMASTER communication driver

On the MCU side, the FreeMASTER software driver is included in the project file structure. It is a set of files supporting real-time data capture (Scope, Recorder) and handling the communication protocol. There are some functions that are unique for each MCU family, therefore FreeMASTER is issued for each MCU family separately. In the “freemaster_cfg.h” file, the user can perform settings related to the communication and to the data buffer. In the file are defined macros for conditional and parameter compilation. The FreeMASTER driver does not perform any initialization or configuration of the SCI module it uses to communicate.

The communication between the MCU and the PC side can be performed with help of the interrupt or via periodic calling of the polling function. For a motor control application, the polling mode is preferred. Both the communication and protocol decoding are handled in the application background loop. The polling mode requires a periodic call of the FMSTR_Poll() function in the application main.

4.6.3 FreeMASTER recorder and scope

The recorder is also a part of the FreeMASTER software which is able to sample the application variables at a specified sample rate. The samples are stored in a buffer and read by the PC via an RS-232 serial port. The sampled data can be displayed in a graph, or the data can be stored. The recorder behaves as an on-chip oscilloscope with trigger/pre-trigger capabilities. The size of the recorder buffer and the FreeMASTER recorder time base can be defined in the “freemaster_cfg.h” configuration file. The recorder routine must be called periodically from the loop from where you want to take the samples. The following line must be added to the loop code:

```
/* Freemaster recorder */  
FMSTR_Recorder();
```

In this application, the FreeMASTER recorder is called from the ADC1 interrupt, which creates a 63 μ s time base for the recorder function. Buffered data is transferred to the PC side after the trigger condition is met.

The FreeMASTER Scope is a similar visualization tool to the Recorder, but the data from the embedded side is downloaded in real-time. The sampling rate is limited by the speed of the communication protocol and also influenced by the number of displayed variables. It is usually used for waveforms visualization of slow transient phenomena, such as the speed profile during motor acceleration.

4.7 Program flow

4.7.1 Application structure

Figure 4-3 is the application software structure.

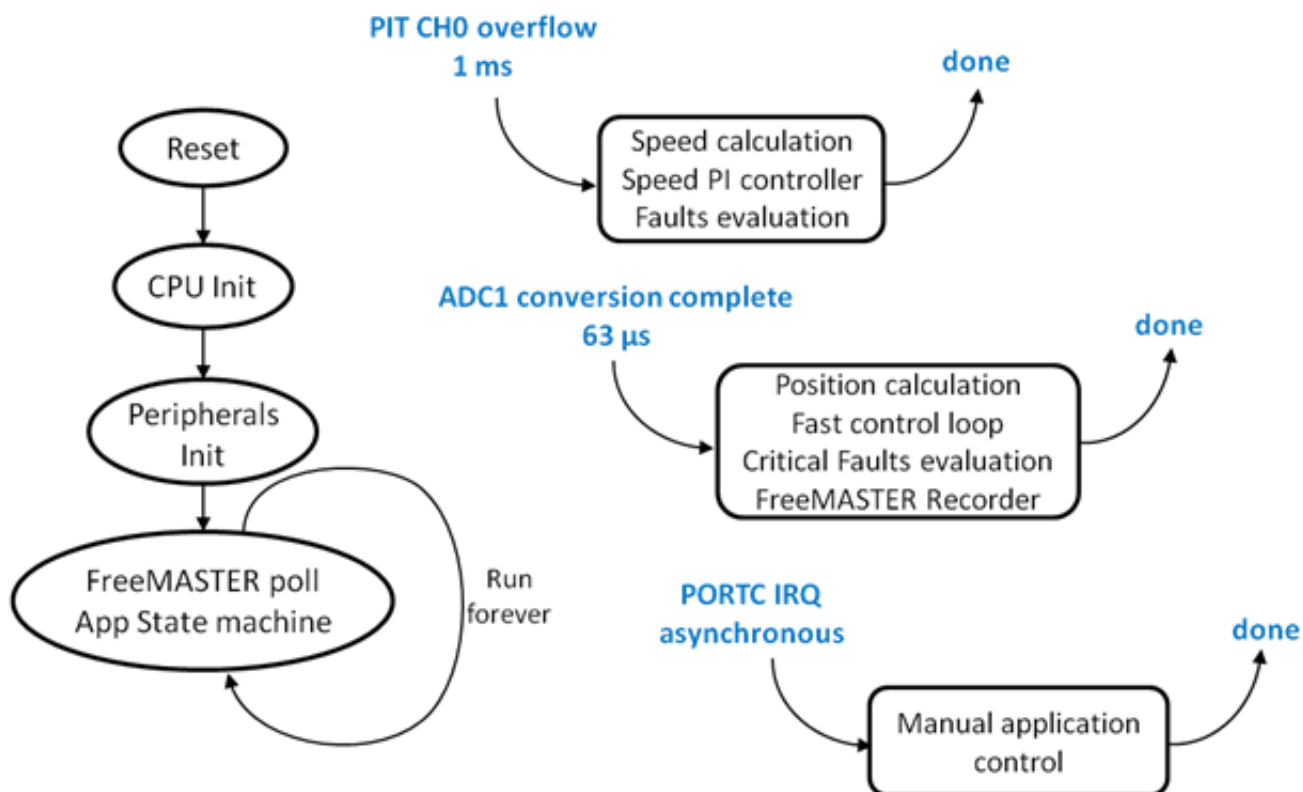

Figure 4-3. Application structure

The software structure consists of the application main routine which enters after the CPU reset. Here the CPU and peripherals initialize, the Application State Machine is serviced, and the interrupts generated periodically, where the motor control algorithms are executed.

4.7.2 Application background loop

The endless application background loop contains only two lines - calls to two functions:

The FreeMASTER communication polling function `FMSTR_Poll()` ;

The application state machine `AppStateMachine[appState]()` ;

The main application-control tasks are executed in the interrupt service routines that interrupt the background loop.

4.7.3 Application state machine

A simple application state machine handles the switching between the application states and application state transitions. This is executed in the infinite background loop in the program main. The following figure gives an overview of the program flow through the application states and transitions.

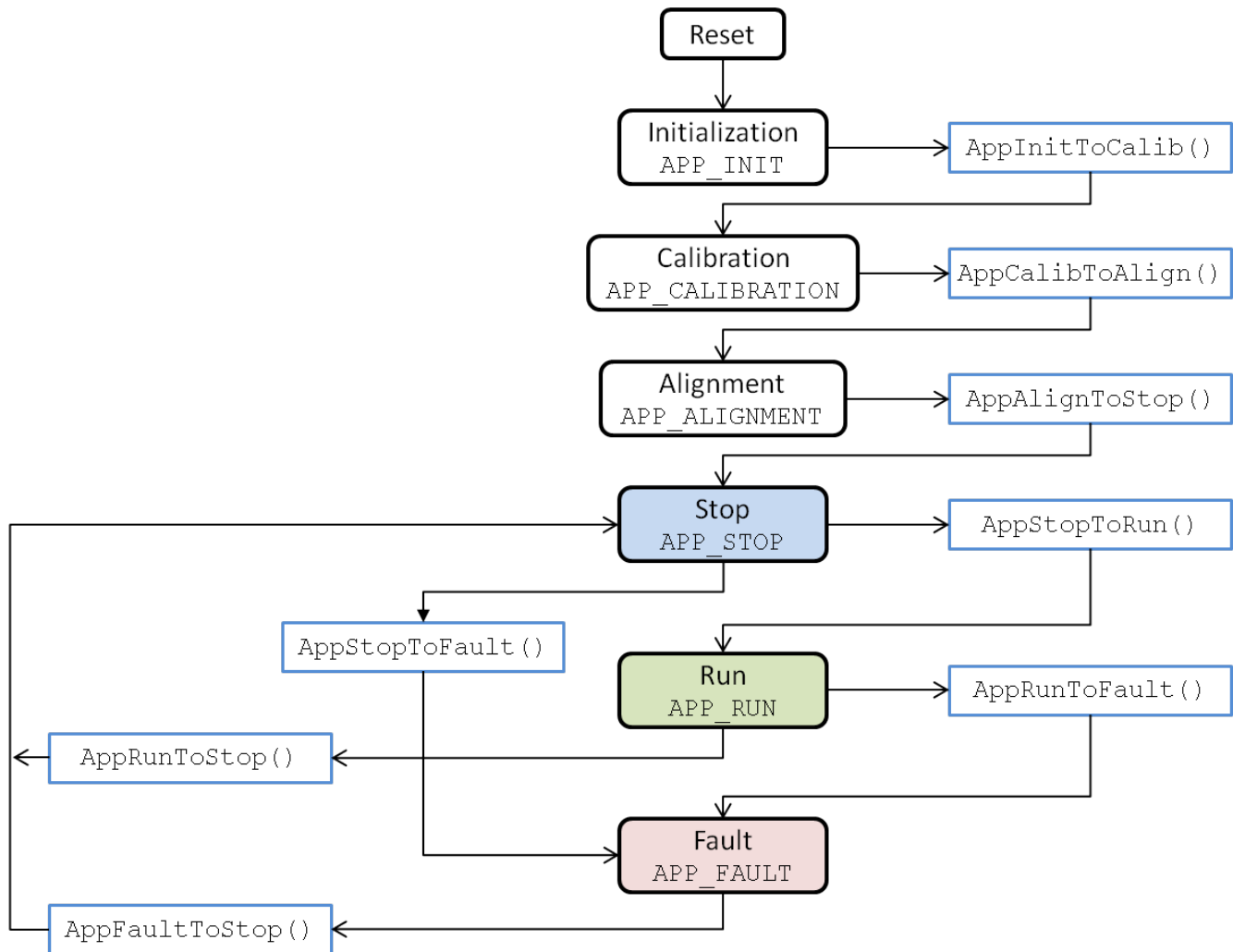

Figure 4-4. Application state machine diagram

The application states represent a steady state. This means that usually, the application is waiting on some trigger or condition to change the state. The particular function is called each time the program makes one pass of the infinite background loop. The application state transitions contain instructions that are executed only once when the application state is changed. Typically, the settings in the peripheral registers are performed only once, and it is not necessary to repeat them.

4.7.3.1 States definition

- **APP_INIT**
The default state after the MCU reset. The peripherals are configured, the MOSFET driver MC33937 is initialized and the interrupts are enabled. This particular state function is executed only once and transitions to the Calibration state.
- **APP_CALIBRATION**
Calibration of the offset on the ADC channels for all three phase currents is performed. The values are stored in the ADC offset registers. The offset value represents the zero current and is automatically subtracted from the sampled value during the motor run, so there is already a positive or negative value of the current available in the ADC result register.
- **APP_ALIGNMENT**
The rotor is aligned to a known position by applying only the d-portion of d,q current system.
- **APP_STOP**
The application is fully initialized and is awaiting the start of the motor run, either by pressing the Start button or setting the state variable from the FreeMASTER software. The PWM output pads are still disabled. The Stop state can also be entered from the Run state.
- **APP_RUN**
The voltage is applied to the motor and the speed of the motor is regulated according to the required speed profile.
- **APP_FAULT**
The application waits for the fault removal and fault acknowledgment.

4.7.3.2 Transitions definition

- **AppInitToCalib**
In this subroutine, all application variables are initialized to their default values.
- **AppCalibToAlign**
Enables the PWM output pads, assigns the default ADC channels to the ADC modules and enables the ADC interrupt, so that the vector control algorithm can be performed during the rotor alignment process.
- **AppAlignToStop**

After the rotor alignment, the quadrature decoder counter (FTM1 counter) is cleared and all variables are set to their default values. The PWM output pads are disabled.

- **AppStopToRun**

The PWM output pads are enabled and the variables are again set to default values (except for the speed and position related calculation), just in case there was an attempt to run the motor in the stop state. Toggling the user's LEDs on the K40 tower board signals the change of state.

- **AppRunToStop**

If the speed is non-zero, the application waits till the motor stops by forcing the required speed to zero. If the motor is in standstill, the PWM output pads are disabled. Toggling the user's LEDs on the K40 tower board signals the change of state.

- **AppRunToFault**

The PWM output pads are disabled. The user's LEDs on the K40 tower board are toggled to signal the change of the state. See the triggering events in Section 5.

- **AppStopToFault**

In the Stop state measurement of the DC-Bus voltage is performed, and the value is compared against the overvoltage threshold. The application can enter the Fault state from the Stop state in the case of an overvoltage error.

- **AppFaultToStop**

Performing the reset and re-initialization of the MC33937 MOSFET driver after a fault was acknowledged.

4.7.4 Interrupts

The application requires the minimum number of interrupts because the MCU has the possibility of hardware triggering the AD conversion and the FlexTimer is able to effectively decode quadrature encoder signals.

4.7.4.1 PIT channel 0 interrupt

In this interrupt service routine, the speed control loop is executed and the interrupt also serves as a precise 1 ms time base for speed computing. Because the speed is calculated as a derivation of the position, the precision of the time base is critical for obtaining the speed values. Therefore, the interrupt has the highest priority. The speed calculation is described in the application note titled *Configuring the FlexTimer for Position and Speed Measurement with an Encoder* (document AN4381 [7]).

After the speed calculation, there is detection of the disconnected motor phase. The loss of the voltage on one motor phase results in the generation of a rotating magnetic field in the opposite direction than that of the required speed. The PI speed regulator generates each time a higher value of i_q (torque producing) current because the regulation error between the measured and required speed increases during acceleration. The motor reaches quickly the maximum speed in the opposite direction. This behavior is unwanted and needs to be managed by software. The detection is based on the hazardous state described above. The required and actual speed has to have the same orientation, otherwise the fault is triggered and the motor is disconnected from the voltage.

Then, the speed PI controller is calculated. The step change in the required speed is ramp limited prior to the regulation error being computed. As mentioned, the output of the speed regulator is the required q-axis component of the current that is directly proportional to the required torque needed for motor acceleration, or for overcoming all drive frictions while maintaining a constant speed.

In the PIT channel 0 ISR, there is also a periodic check on the status register of the MOSFET driver MC33937 via the SPI interface. When any fault is latched by the driver, the application is forced into the fault state and the user can check the source of the fault via the FreeMASTER control interface. For more details, see the User’s Manual [13]. Table 4-2 summarizes the software routines executed in the PIT CH0 ISR.

Table 4-2. Software routines executed in the PIT CH0 ISR

PIT CH0 ISR	Speed calculation
	Speed filtering (moving average)
	Motor phase disconnection detection
	Ramp limitation of the required speed
	Speed PI controller calculation
	MOSFET driver status register check

4.7.4.2 ADC1 interrupt

This interrupt request is triggered when the conversion of channel A of the ADC1 module is completed. At the moment of the interrupt generation, there are sampled values of physical quantities ready: in the Result Registers A of the ADC0 (DC bus voltage), Result Register B of the ADC0 (motor phase current 1) and Result Register A of the ADC1 module (motor phase current 2). The interrupt is always enabled only for one module, otherwise there would be two interrupt requests generated at the same time; this is because the triggers for motor phase currents are generated in the same instance. In the

ADC1 ISR there is the fast (current) control loop of the PMSM vector control executed. Besides the control algorithm computation, there are also other supporting routines executed, an overview is summarized in the following table.

Table 4-3. Software routines executed in the ADC1 ISR

ADC1 ISR	Reading the ADC result registers (2) based on the actual SVM sector, calculation of the third current		
	Software overcurrent and overvoltage detection		
	Calculation of the rotor position from the encoder signals		
	Fast control loop	Clarke transformation	
		Sin	
		Cos	
		Park transformation	
		D-current controller output limitation calculation	
		D-current PI controller	
		Q-current controller output limitation calculation (included SQRT)	
		Q-current PI controller	
		Inverse Park transformation	
		Elimination of DC bus voltage ripple	
Space vector modulation			
PWM registers update (with the calculated duty cycle)			

4.7.4.3 PORTC interrupt

Handling user buttons on the K40 tower board is performed in the ISR associated with the PORTC interrupt, generated whenever one of the buttons is pressed. At the beginning of the ISR, simple logic is executed to evaluate what button is pressed, and the interrupt flag is cleared. Because there are only two user buttons (in the application the assigned functions are RUN and STOP), there is limited control possibility (rotation only in one direction). Pressing the RUN button causes the speed to increase in 10% steps. Pressing the STOP button causes the speed to decrease in 10% steps and also a fault acknowledgment.

More about the application control via the user buttons in the chapter “Application control”. Using the FreeMASTER control interface allows for enhanced control and diagnostic. See details in the same chapter.

4.7.5 Project file structure

The total number of source files (*.c) in the project is 36 and there are an additional 86 header (*.h) files in the project tree. Therefore, only the key project files will be described in more detail, and the rest will be described in groups.

The main project folder is divided into three directories:

- **build** — Contains configuration files for the IAR compiler as well as the compiler's output executable and object files. If the IAR Embedded Workbench for ARM is installed on your computer, double clicking the workspace file TWRK40X256_PMSM_FOC.eww located in the directory \build\iar\ would launch the IAR IDE.
- **gui** — Contains the FreeMASTER configuration file (Kinetis_FOC_demo.pmp) and supporting files (control page in HTML format and the binary file with addresses of the variables)
- **src** — Contains the project source and header files, and its contents will be described in the following text.

Files in the root of the src folder:

main.c contains — Application control interrupt routines (fast and slow control loops) as well as the background infinite loop with the application state machine

main.h — Header file of the main application file, containing the macros and structures related to the application control and constant definitions related to the application state machine.

enc.c and **enc.h** — Contain the position and speed calculation from quadrature encoder signals

freemaster_cfg.h — Configuration file for the FreeMASTER interface

PMSMFOC_appconfig.h — Contains constants definition for the application control processes (parameters of the motor and regulators, and the constants for other vector control related algorithms). The regulators' parameters can easily be calculated using the K40_PMSM_Encoder_config.xls file, but the system parameters have to be identified.

Files and subdirectories in the src\mcu_Init\ folder:

\common and **\cpu** — Folders containing CPU initialization routines

\cpu\vectors.h — An important file with definition of the peripherals interrupt service routines assigned to the interrupt vectors. In this file, you can add the definition of an ISR for an additional peripheral interrupt.

\drivers — Files in the subdirectories contain generic source and header files for UART and watchdog configuration, as well as the CPU clock settings routines

\peripherals — Contains important files for static configuration of the peripherals used in the application (FlexTimers, ADC, PDB, SPI, PIT)

\platforms\tower.h — Contains the Kinetis Tower card definitions (CPU speed and UART parameters)

Files in the src\twrk40x256\ folder:

MK40X256VMD100.h — Header file containing macro definitions of all the MCU registers and register bits

Files in the src\MC_Lib\ folder:

Cortex_M4.a — Software library containing motor control, general math and filter algorithms. Other files in the folder and subfolders are associated header files, each one for a particular function of the library.

Other subdirectories in the src\ folder:s

\src\FreeMASTER — Contains all source files of the FreeMASTER application, it is not necessary to access it or change anything inside. The interface to the programmer is only via freemaster_cfg.h file.

\src\Common — Contains specific header files associated with the software libraries

4.7.6 Memory usage

The following table summarizes chip memory usage:

Memory	Total Available on the Kinetis MK40X256VMD100	Used by the Application
Program Flash (application code)	256 000	20 994
Data Flash (application constants)		2 106
Data RAM (application variables)	64 000	1 662

Chapter 5

Application Setup and Operation

5.1 Application set-up and operation

The application can be operated via the user's buttons on the K40 tower module or via the FreeMASTER interface. The set-up procedure of the FreeMASTER software on the PC, as well as the application operation, is described in the User's Manual [13].



Chapter 6

Measurement Results

6.1 CPU load and the execution time

The CPU load is influenced mainly by the execution of the ADC1 ISR, in which the calculation of the fast (current) control loop of the PMSM vector control is performed.

The complete ADC1 ISR requires 1628 machine cycles. It is executed periodically with the same frequency as the PWM reload event, when the values of the duty cycles are updated.

In this application, the fast control loop is executed once per 63 μs which corresponds to 16 kHz of the PWM frequency. At 100 MHz on the Kinetis K40 device, it consumes roughly 35% of CPU performance.

6.2 Measurement results using FreeMASTER

6.2.1 3-phase current reconstruction

Figure 6.2, is the measurement of the 3-phase motor currents. The values are captured using the FreeMASTER recorder.

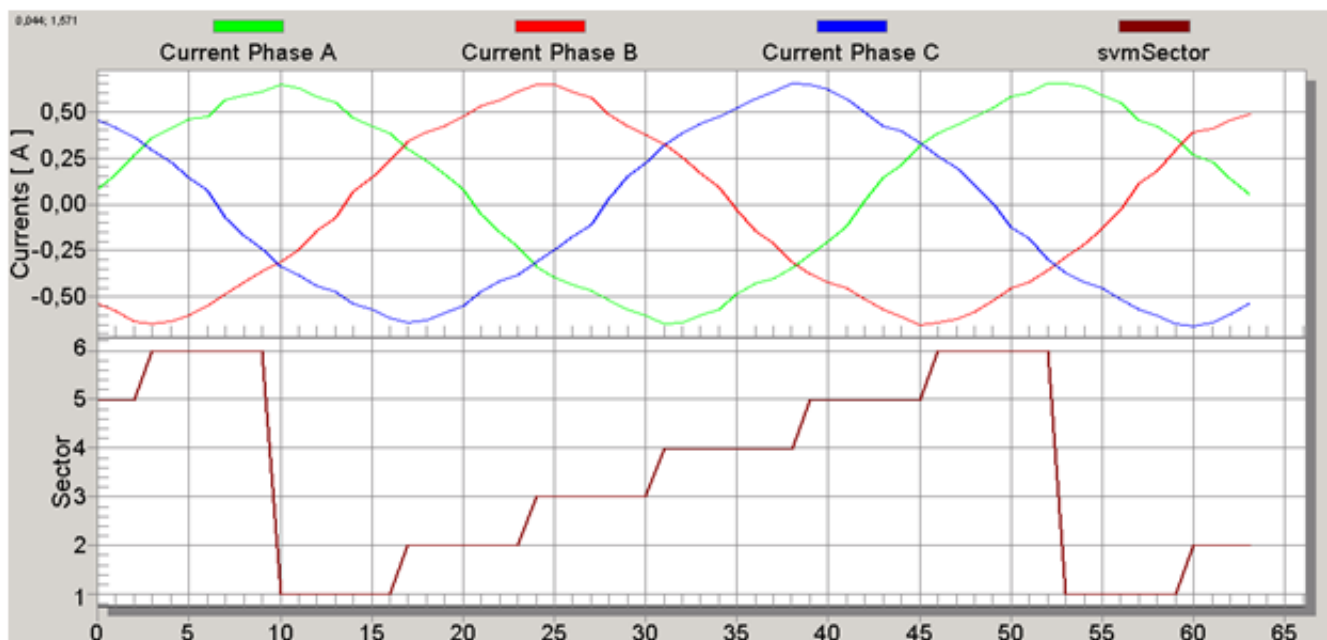

Figure 6-1. Motor phase currents and SVM sector

6.2.2 Speed controller

The PI speed controller is executed in the PIT CH0 ISR, once per 1 ms. The parameters of the regulator were tuned to obtain a sharp step response without overshoot.

The following figure shows the speed profile; the required and measured speeds. At first, the motor is set to run at a nominal speed of 3000 rpm in a clockwise direction, then reversed to a counter-clockwise direction, -3000 rpm.

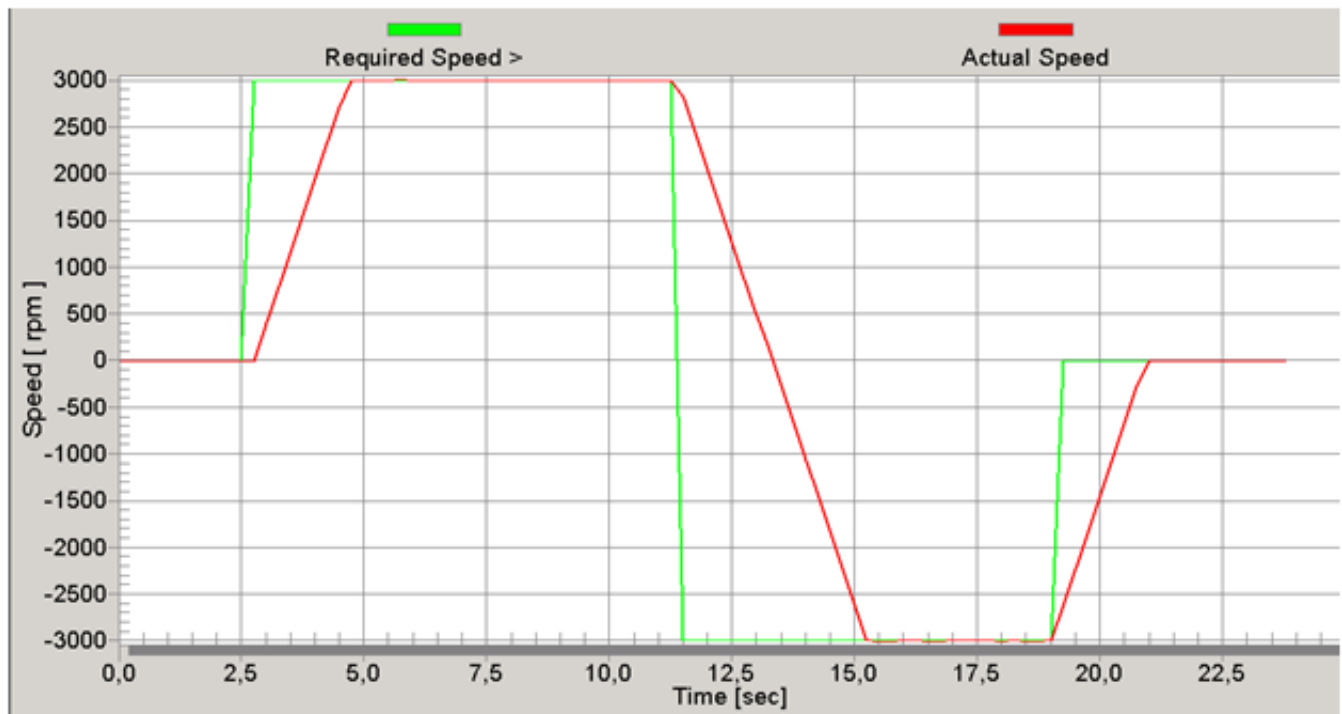

Figure 6-2. Speed profile

Chapter 7

References

7.1 References

- [1] *K40 Sub-Family Reference Manual*, Freescale Semiconductor, 2011
- [2] *IAR C/C++ Development Guide, Compiling and Linking for Advanced RISC Machines Ltd's ARM® Cores*, IAR Systems AB, 2011
- [3] Designer reference manual titled *PM Sinusoidal Motor Vector Control with Quadrature Encoder* (document DRM105) Devices Supported—MCF51AC256, Freescale Semiconductor, 2008
- [4] User reference manual *Set of General Math and Motor Control Functions for Cortex M4 Core* (document number MCLIBCORETXM4UG) Freescale Semiconductor, 2011
- [5] Matus Plachy, Anders Lundgren, Lotta Frimanson: *Designing advanced DSP applications on the Kinetis Cortex-M4 MCU* Embedded World 2011 Conference and Exhibition
- [6] Application note titled *Using FlexTimer in ACIM/PMSM Motor Control Applications* (document number AN3729) Freescale Semiconductor, 2008
- [7] Application note titled *Configuring FlexTimer for Position and Speed Measurement with Encoder* (document number AN4381) Freescale Semiconductor 2011
- [8] Advanced information document titled *Three Phase Field Effect Transistor Pre-driver* (document number MC33937) Freescale Semiconductor 2009
- [9] Reference Manual titled *ARM®v7-M Architecture* , ARM Limited 2010
- [10] Data sheet titled *K40 Sub-Family Data Sheet* (document number K40P144M100SF2), Freescale Semiconductor 2011
- [11] Application note titled *Real Time Development of MC Applications using the PC Master Software Visualization Tool* (document number AN1948) , Freescale Semiconductor 2005

[12] User’s manual *TWR–MC–LV3PH* , Freescale Semiconductor 2011

[13] Demo set-up guide *PMSM Vector Control with Encoder on Kinetis*, Freescale Semiconductor 2011

[14] *Mask Set Errata for Mask 0M33Z*, Freescale Semiconductor 2011

7.2 Acronyms and Abbreviations

Table 7-1. Acronyms and abbreviated terms

Term	Meaning
AC	Alternating current
ADC	Analog-to-digital converter
BDM	Background Debug Mode
DC	Direct current
DMA	Direct Memory Access Controller — An MCU module capable of performing complex data transfers with minimal intervention from a host processor.
DSC	Digital Signal Controller
DT	Dead time — A short time that must be inserted between the turning off of one transistor in the inverter half bridge and the turning on of the complementary transistor due to limited switching speed of the transistors
FOC	Field Oriented Control
FTM	FlexTimer module — A timer module on the Kinetis K40 MCU that serves for generating of the 6-channel PWM
GPIO	General purpose input/output
IAR	The name of the company producing compilers for different platforms and MCU manufacturers, including ARM
IDE	Integrated Development Environment
I/O	Input/output interfaces between a computer system and the external world. A CPU reads an input to sense the level of an external signal and writes to an output to change the level of an external signal.
ISR	Interrupt Service Routine — A fragment of code (a function) that is executed when interrupts from the core or from the peripheral modules are generated.
LED	Light emitting diode
K40	Freescale Kinetis MK40 ARM Cortex-M4 32-bit microcontroller
MTPA	Maximum Torque per Amp Algorithm — A special algorithm used in vector control of AC motors. Thanks to this algorithm, the efficiency and the power of the motor is increased by using the reluctance torque of the motor.
MSB	Most Significant Bit
NVIC	Nested Vector Interrupt Controller— An integral part of the ARMv7 core responsible for the interrupts processing
PDB	Programmable Delay Block
PI controller	Proportional-integral controller

Table continues on the next page...

Table 7-1. Acronyms and abbreviated terms (continued)

Term	Meaning
PIT	Periodic Interrupt Timer
PMSM	PM Synchronous Motor, permanent magnet synchronous motor
PWM	Pulse Width Modulation
RPM	Revolutions Per Minute
SCI	Serial Communication Interface, see also UART
SPI	Serial Peripheral Interface
UART	Universal Asynchronous Receiver/Transmitter — An MCU peripheral module allowing asynchronous serial communication between the MCU and other systems



How to Reach Us:

Home Page:

www.freescale.com

Web Support:

<http://www.freescale.com/support>

USA/Europe or Locations Not Listed:

Freescale Semiconductor
 Technical Information Center, EL516
 2100 East Elliot Road
 Tempe, Arizona 85284
 +1-800-521-6274 or +1-480-768-2130
www.freescale.com/support

Europe, Middle East, and Africa:

Freescale Halbleiter Deutschland GmbH
 Technical Information Center
 Schatzbogen 7
 81829 Muenchen, Germany
 +44 1296 380 456 (English)
 +46 8 52200080 (English)
 +49 89 92103 559 (German)
 +33 1 69 35 48 48 (French)
www.freescale.com/support

Japan:

Freescale Semiconductor Japan Ltd.
 Headquarters
 ARCO Tower 15F
 1-8-1, Shimo-Meguro, Meguro-ku,
 Tokyo 153-0064
 Japan
 0120 191014 or +81 3 5437 9125
support.japan@freescale.com

Asia/Pacific:

Freescale Semiconductor China Ltd.
 Exchange Building 23F
 No. 118 Jianguo Road
 Chaoyang District
 Beijing 100022
 China
 +86 10 5879 8000
support.asia@freescale.com

For Literature Requests Only:

Freescale Semiconductor Literature Distribution Center
 1-800-441-2447 or +1-303-675-2140
 Fax: +1-303-675-2150
LDCForFreescaleSemiconductor@hibbertgroup.com

Information in this document is provided solely to enable system and software implementers to use Freescale Semiconductors products. There are no express or implied copyright licenses granted hereunder to design or fabricate any integrated circuits or integrated circuits based on the information in this document.

Freescale Semiconductor reserves the right to make changes without further notice to any products herein. Freescale Semiconductor makes no warranty, representation, or guarantee regarding the suitability of its products for any particular purpose, nor does Freescale Semiconductor assume any liability arising out of the application or use of any product or circuit, and specifically disclaims any liability, including without limitation consequential or incidental damages. "Typical" parameters that may be provided in Freescale Semiconductor data sheets and/or specifications can and do vary in different applications and actual performance may vary over time. All operating parameters, including "Typicals", must be validated for each customer application by customer's technical experts. Freescale Semiconductor does not convey any license under its patent rights nor the rights of others. Freescale Semiconductor products are not designed, intended, or authorized for use as components in systems intended for surgical implant into the body, or other applications intended to support or sustain life, or for any other application in which failure of the Freescale Semiconductor product could create a situation where personal injury or death may occur. Should Buyer purchase or use Freescale Semiconductor products for any such unintended or unauthorized application, Buyer shall indemnify Freescale Semiconductor and its officers, employees, subsidiaries, affiliates, and distributors harmless against all claims, costs, damages, and expenses, and reasonable attorney fees arising out of, directly or indirectly, any claim of personal injury or death associated with such unintended or unauthorized use, even if such claims alleges that Freescale Semiconductor was negligent regarding the design or manufacture of the part.

RoHS-compliant and/or Pb-free versions of Freescale products have the functionality and electrical characteristics as their non-RoHS-complaint and/or non-Pb-free counterparts. For further information, see <http://www.freescale.com> or contact your Freescale sales representative.

For information on Freescale's Environmental Products program, go to <http://www.freescale.com/epp>.

Freescale™ and the Freescale logo are trademarks of Freescale Semiconductor, Inc. All other product or service names are the property of their respective owners.

© 2012 Freescale Semiconductor, Inc.