

Getting Started with MCUXpresso SDK for MIMXRT106X

1 Overview

The MCUXpresso Software Development Kit (SDK) provides comprehensive software support for Kinetis and LPC Microcontrollers. The MCUXpresso SDK includes a flexible set of peripheral drivers designed to speed up and simplify development of embedded applications. Along with the peripheral drivers, the MCUXpresso SDK provides an extensive and rich set of example applications covering everything from basic peripheral use case examples to full demo applications. The MCUXpresso SDK contains FreeRTOS and various other middleware to support rapid development.

For supported toolchain versions, see the MCUXpresso SDK Release Notes Supporting EVK-MIMXRT1060 (document MCUXSDKMIMXRT106XRN).

For more details about MCUXpresso SDK, see the MCUXpresso SDK homepage [MCUXpresso-SDK: Software Development Kit for MCUXpresso](#).

Contents

1	Overview.....	1
2	MCUXpresso SDK board support folders.....	2
3	Run a demo application using IAR.....	3
4	Run a demo using Keil® MDK/µVision.....	7
5	Run a demo using Arm® GCC.....	11
6	Run a demo using MCUXpresso IDE....	20
7	MCUXpresso Config Tools.....	31
8	MCUXpresso IDE New Project Wizard.....	32
9	Appendix A - How to determine COM port.....	32
10	Appendix B - How to add or remove boot header for XIP targets.....	34
11	Revision history.....	37



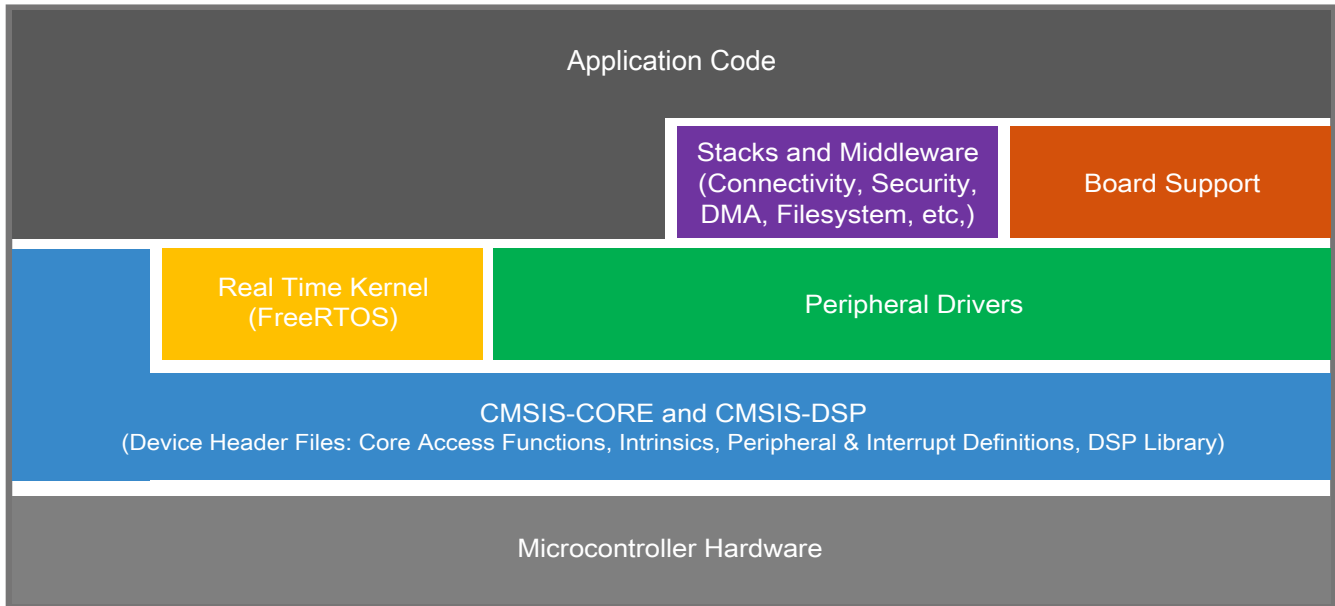

Figure 1. MCUXpresso SDK layers

2 MCUXpresso SDK board support folders

MCUXpresso SDK board support provides example applications for NXP development and evaluation boards for Arm[®] Cortex[®]-M cores, including Freedom, Tower System, and LPCXpresso boards. Board support packages are found inside of the top level boards folder, and each supported board has its own folder (an MCUXpresso SDK package can support multiple boards). Within each <board_name> folder, there are various sub-folders to classify the type of examples they contain. These include (but are not limited to):

- demo_apps: Full-featured applications intended to highlight key functionality and use cases of the target MCU. These applications typically use multiple MCU peripherals and may leverage stacks and middleware.
- driver_examples: Simple applications intended to concisely illustrate how to use the MCUXpresso SDK’s peripheral drivers for a single use case. These applications typically only use a single peripheral, but there are cases where multiple are used (for example, SPI conversion using DMA).
- rtos_examples: Basic FreeRTOS[™] OS examples showcasing the use of various RTOS objects (semaphores, queues, and so on) and interfacing with the MCUXpresso SDK’s RTOS drivers

2.1 Example application structure

This section describes how the various types of example applications interact with the other components in the MCUXpresso SDK. To get a comprehensive understanding of all MCUXpresso SDK components and folder structure, see the *MCUXpresso SDK API Reference Manual* document (MCUXSDKAPIRM).

Each <board_name> folder in the boards directory contains a comprehensive set of examples that are relevant to that specific piece of hardware. Although we use the hello_world example (part of the demo_apps folder), the same general rules apply to any type of example in the <board_name> folder.

In the hello_world application folder you see the following contents:

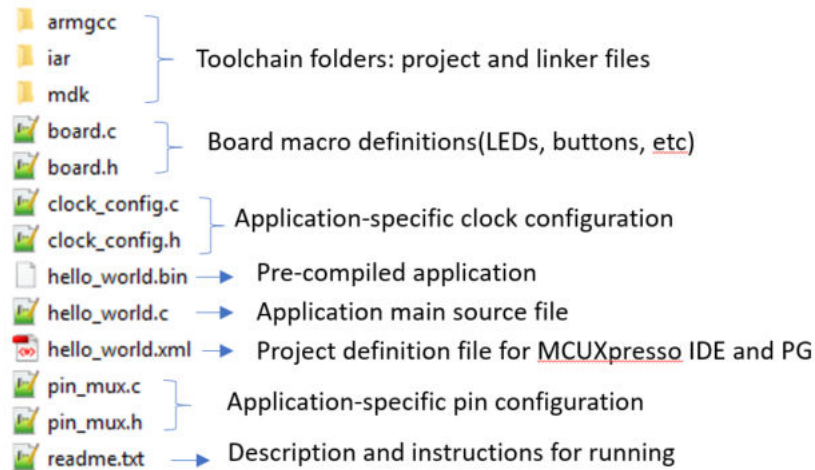

Figure 2. Application folder structure

All files in the application folder are specific to that example, so it is easy to copy and paste an existing example to start developing a custom application based on a project provided in the MCUXpresso SDK.

2.2 Locating example application source files

When opening an example application in any of the supported IDEs (except MCUXpresso IDE), a variety of source files are referenced. The MCUXpresso SDK devices folder is the central component to all example applications. It means the examples reference the same source files and, if one of these files is modified, it could potentially impact the behavior of other examples.

The main areas of the MCUXpresso SDK tree used in all example applications are:

- devices/<device_name>: The device's CMSIS header file, MCUXpresso SDK feature file and a few other things.
- devices/<device_name>/drivers: All of the peripheral drivers for your specific MCU.
- devices/<device_name>/<tool_name>: Toolchain-specific startup code. Vector table definitions are here.
- devices/<device_name>/utilities: Items such as the debug console that are used by many of the example applications.

For examples containing an RTOS, there are references to the appropriate source code. RTOSes are in the *rtos* folder. Again, the core files of each of these are shared, so modifying them could have potential impacts on other projects that depend on them.

3 Run a demo application using IAR

This section describes the steps required to build, run, and debug example applications provided in the MCUXpresso SDK. The `hello_world` demo application targeted for the EVK-MIMXRT1060 hardware platform is used as an example, although these steps can be applied to any example application in the MCUXpresso SDK.

3.1 Build an example application

The following steps guide you through opening the hello_world example application. These steps may change slightly for other example applications as some of these applications may have additional layers of folders in their path.

1. If not already done, open the desired demo application workspace. Most example application workspace files can be located using the following path:

```
<install_dir>/boards/<board_name>/<example_type>/<application_name>/iar
```

Using the EVK-MIMXRT1060 hardware platform as an example, the hello_world workspace is located in

```
<install_dir>/boards/evknimxrt1060/demo_apps/hello_world/iar/hello_world.eww
```

2. Select the desired build target from the drop-down menu.

There are twelve project configurations (build targets) supported for most MCUXpresso SDK projects:

- Debug – Compiler optimization is set to low, and debug information is generated for the executable. The linker file is RAM linker, where text and data section is put in internal TCM.
- Release – Compiler optimization is set to high, and debug information is not generated. The linker file is RAM linker, where text and data section is put in internal TCM.
- ram_0x1400_debug – Project configuration is same as the debug target. The linker file is RAM_0x1400 linker, where text is put in ITCM with offset 0x1400 and data put in DTCM.
- ram_0x1400_release – Project configuration is same as the release target. The linker file is RAM_0x1400 linker, where text is put in ITCM with offset 0x1400 and data put in DTCM.
- sdram_debug – Project configuration is same as the debug target. The linker file is SDRAM linker, where text is put in internal TCM and data put in SDRAM.
- sdram_release – Project configuration is same as the release target. The linker file is SDRAM linker, where text is put in internal TCM and data put in SDRAM.
- sdram_txt_debug – Project configuration is same as the debug target. The linker file is SDRAM_txt linker, where text is put in SDRAM and data put in OCRAM.
- sdram_txt_release – Project configuration is same as the release target. The linker file is SDRAM_txt linker, where text is put in SDRAM and data put in OCRAM.
- flexspi_nor_debug – Project configuration is same as the debug target. The linker file is flexspi_nor linker, where text is put in flash and data put in TCM.
- flexspi_nor_release – Project configuration is same as the release target. The linker file is flexspi_nor linker, where text is put in flash and data put in TCM.
- flexspi_nor_sdram_release - Project configuration is same as the release target. The linker file is flexspi_nor_sdram linker, where text is put in flash and data put in SDRAM.
- flexspi_nor_sdram_debug – Project configuration is same as the debug target. The linker file is flexspi_nor_sdram linker, where text is put in flash and data put in SDRAM.

For some examples need large data memory, only sdram_debug and sdram_release targets are supported.

For this example, select the “hello_world – Debug” target.

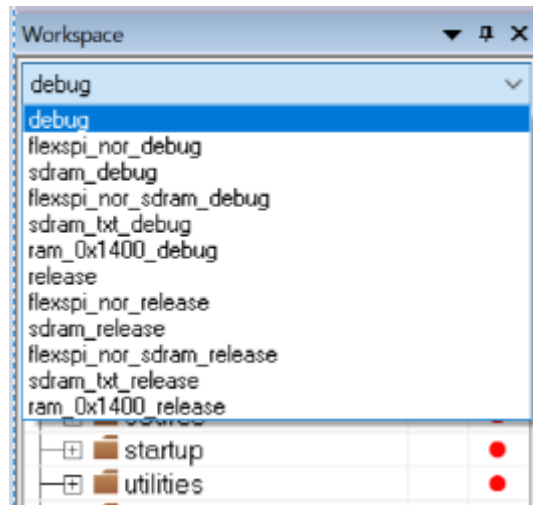

Figure 3. Demo build target selection

- To build the demo application, click the “Make” button, highlighted in red below.

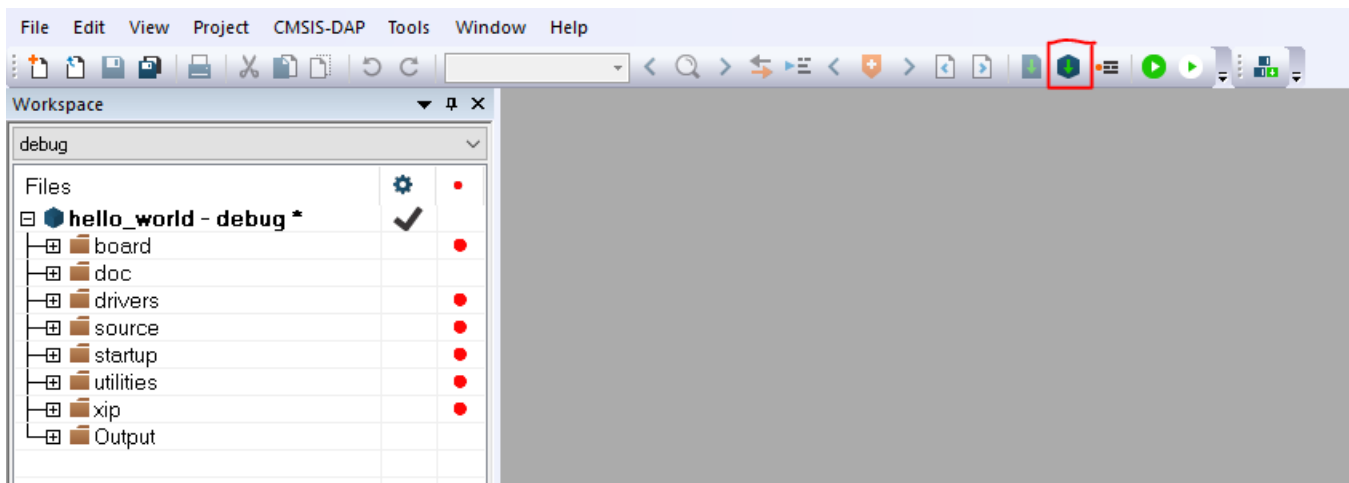

Figure 4. Build the demo application

- The build completes without errors.

3.2 Run an example application

To download and run the application, perform these steps:

- This board supports the CMSIS-DAP/mbed/DAPLink debug probe by default. Visit os.mbed.com/handbook/Windows-serial-configuration and follow the instructions to install the Windows® operating system serial driver. If running on Linux OS, this step is not required.
- Connect the development platform to your PC via USB cable. Connect the USB cable to J41 and make sure SW7[1:4] is 0010b.
- Open the terminal application on the PC, such as PuTTY or TeraTerm, and connect to the debug COM port (to determine the COM port number, see Appendix A). Configure the terminal with these settings:

Run a demo application using IAR

- a. 115200 or 9600 baud rate, depending on your board (reference BOARD_DEBUG_UART_BAUDRATE variable in board.h file)
- b. No parity
- c. 8 data bits
- d. 1 stop bit

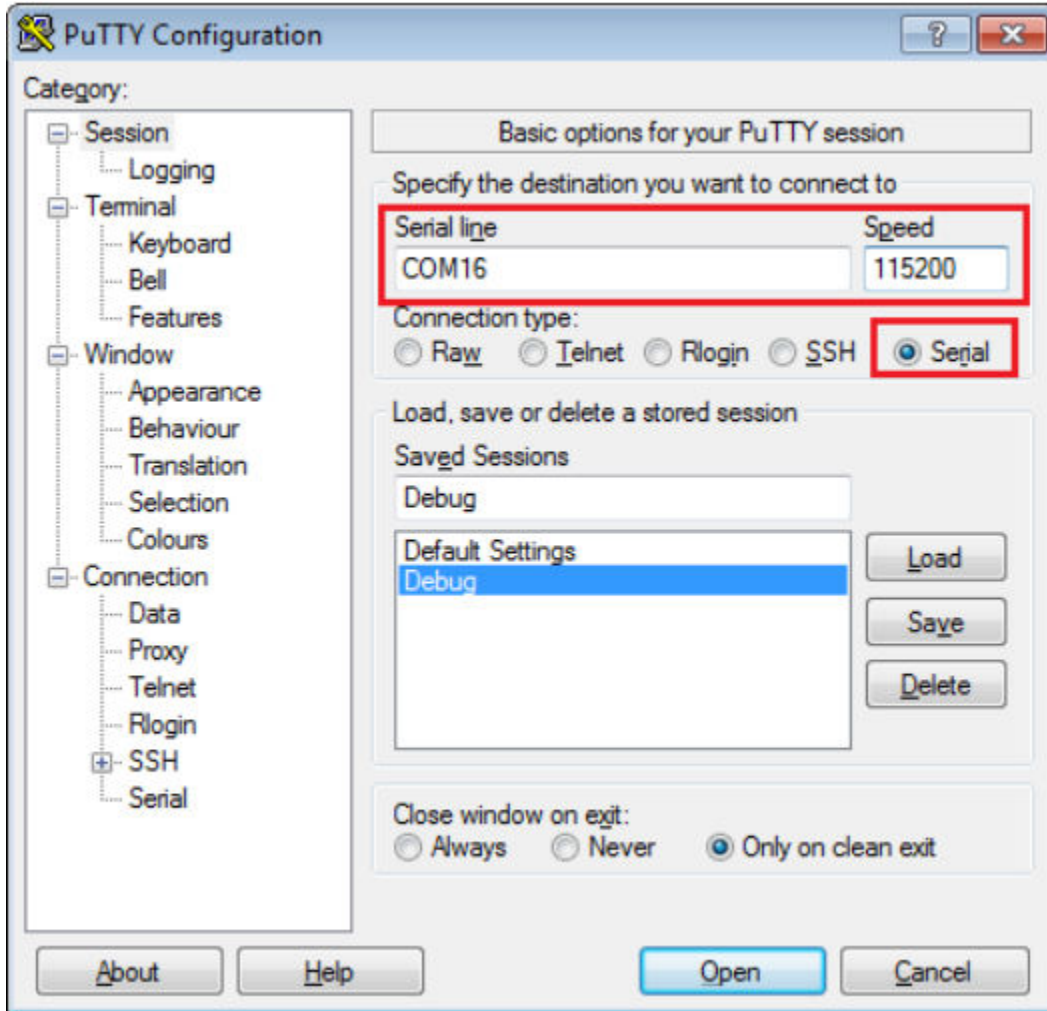

Figure 5. Terminal (PuTTY) configuration

4. In IAR, click the "Download and Debug" button to download the application to the target.



Figure 6. Download and Debug button

5. The application is then downloaded to the target and automatically runs to the main() function.

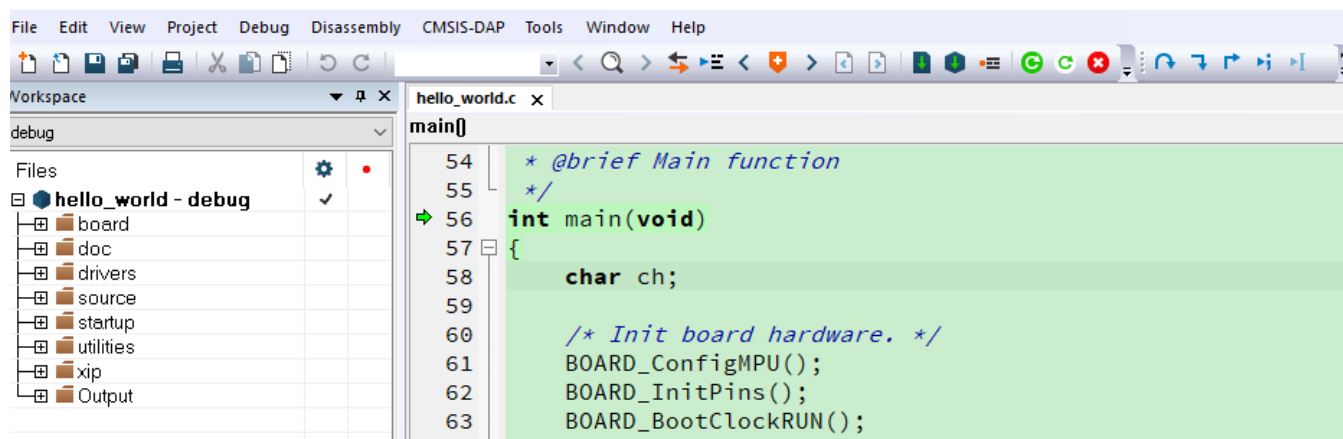

Figure 7. Stop at main() when running debugging

6. Run the code by clicking the "Go" button to start the application.

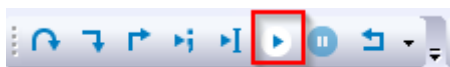

Figure 8. Go button

7. The hello_world application is now running and a banner is displayed on the terminal. If this is not true, check your terminal settings and connections.

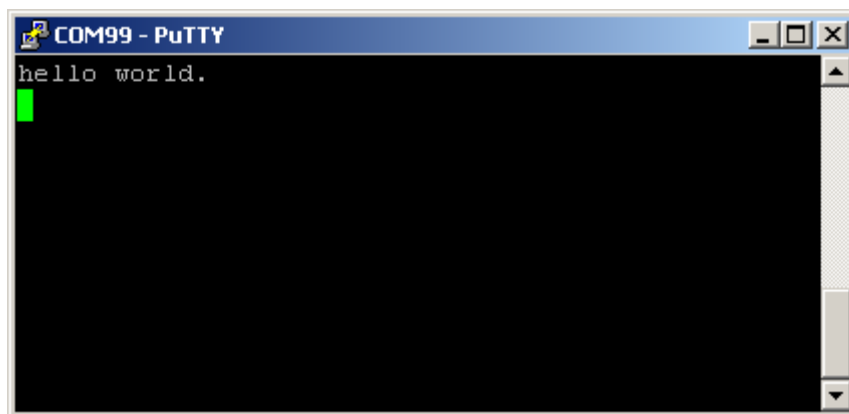

Figure 9. Text display of the hello_world demo

4 Run a demo using Keil® MDK/μVision

This section describes the steps required to build, run, and debug example applications provided in the MCUXpresso SDK.

4.1 Install CMSIS device pack

Run a demo using Keil® MDK/μVision

After the MDK tools are installed, Cortex® Microcontroller Software Interface Standard (CMSIS) device packs must be installed to fully support the device from a debug perspective. These packs include things such as memory map information, register definitions and flash programming algorithms. Follow these steps to install the MIMXRT106x CMSIS pack.

1. Download the MIMXRT1061 and MIMXRT1062 packs.
2. After downloading the DFP, double click to install it.

4.2 Build an example application

- Open the desired example application workspace in: `<install_dir>/boards/<board_name>/<example_type>/<application_name>/mdk`

The workspace file is named `<demo_name>.uvmpw`, so for this specific example, the actual path is:

`<install_dir>/boards/evkmimxrt1060/demo_apps/hello_world/mdk/hello_world.uvmpw`

- To build the demo project, select the "Rebuild" button, highlighted in red.



Figure 10. Build the demo

- The build completes without errors.

4.3 Run an example application

To download and run the application, perform these steps:

1. This board supports the CMSIS-DAP/mbed/DAPLink debug probe by default. Visit os.mbed.com/handbook/Windows-serial-configuration and follow the instructions to install the Windows® operating system serial driver. If running on Linux OS, this step is not required.
2. Connect the development platform to your PC via USB cable.
3. Open the terminal application on the PC, such as PuTTY or TeraTerm, and connect to the debug serial port number (to determine the COM port number, see Appendix A). Configure the terminal with these settings:
 - a. 115200 or 9600 baud rate, depending on your board (reference BOARD_DEBUG_UART_BAUDRATE variable in board.h file)
 - b. No parity
 - c. 8 data bits
 - d. 1 stop bit

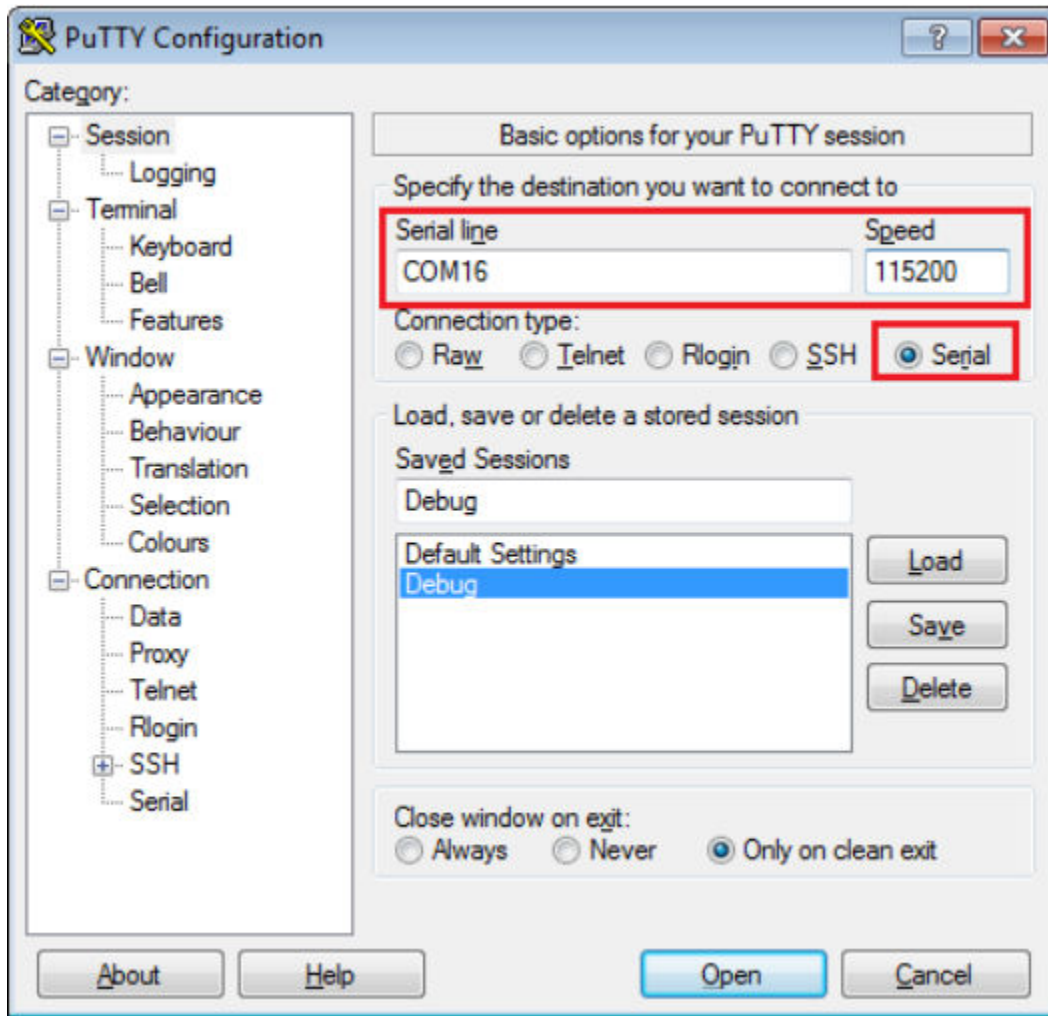

Figure 11. Terminal (PuTTY) configurations

- To debug the application, click the "load (F8)" button if the flexspi_nor target is used. Then, click the "Start/Stop Debug Session" button, highlighted in red. If using J-Link as the debugger, "SW" should be selected in project option --> Debug --> Settings --> Debug -->Port.

Run a demo using Keil® MDK/μVision

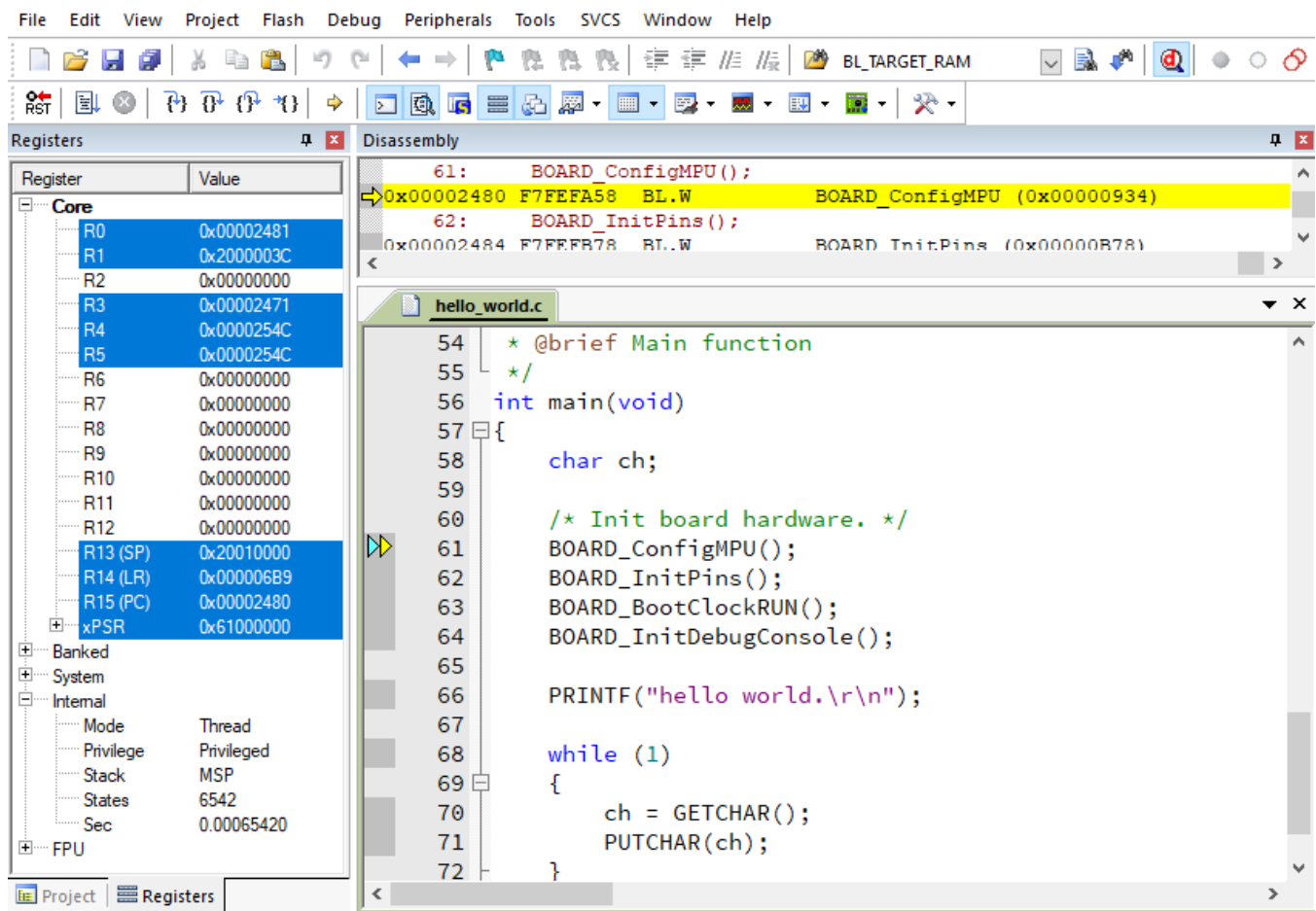

Figure 12. Stop at main() when run debugging

5. Run the code by clicking the “Run” button to start the application.

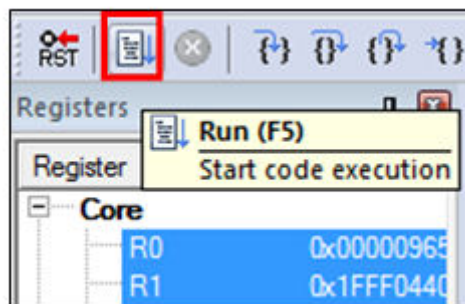

Figure 13. Run button

The hello_world application is now running and a banner is displayed on the terminal. If this is not true, check your terminal settings and connections.

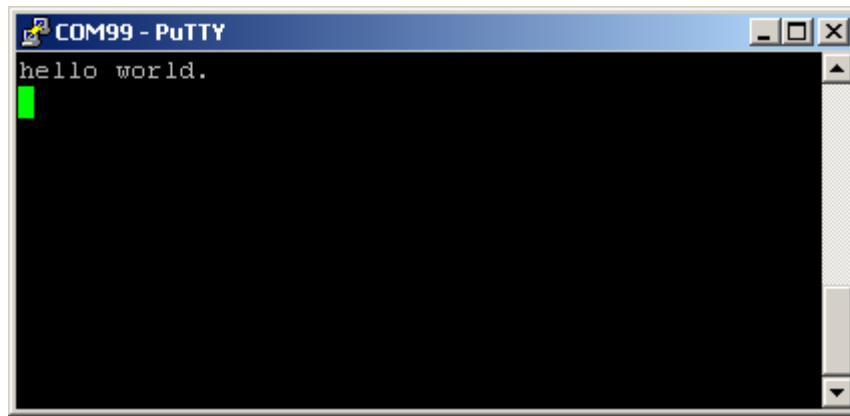

Figure 14. Text display of the hello_world demo

5 Run a demo using Arm® GCC

This section describes the steps to configure the command line Arm® GCC tools to build, run, and debug demo applications and necessary driver libraries provided in the MCUXpresso SDK. The hello_world demo application is targeted as an example, though these steps can be applied to any board, demo or example application in the MCUXpresso SDK.

5.1 Set up toolchain

This section contains the steps to install the necessary components required to build and run an MCUXpresso SDK demo application with the Arm GCC toolchain, as supported by the MCUXpresso SDK. There are many ways to use Arm GCC tools, but this example focuses on a Windows operating system environment.

5.1.1 Install GCC ARM Embedded tool chain

Download and run the installer from launchpad.net/gcc-arm-embedded. This is the actual toolset (in other words, compiler, linker, etc.). The GCC toolchain should correspond to the latest supported version, as described in the *MCUXpresso SDK Release Notes Supporting EVK-MIMXRT1060* (document MCUXSDKMIMXRT106XRN).

5.1.2 Install MinGW (only required on Windows OS)

The Minimalist GNU for Windows (MinGW) development tools provide a set of tools that are not dependent on third party C-Runtime DLLs (such as Cygwin). The build environment used by the MCUXpresso SDK does not utilize the MinGW build tools, but does leverage the base install of both MinGW and MSYS. MSYS provides a basic shell with a Unix-like interface and tools.

1. Download the latest MinGW mingw-get-setup installer from sourceforge.net/projects/mingw/files/Installer/.
2. Run the installer. The recommended installation path is C:\MinGW, however, you may install to any location.

NOTE

The installation path cannot contain any spaces.

3. Ensure that the “mingw32-base” and “msys-base” are selected under Basic Setup.

Run a demo using Arm® GCC

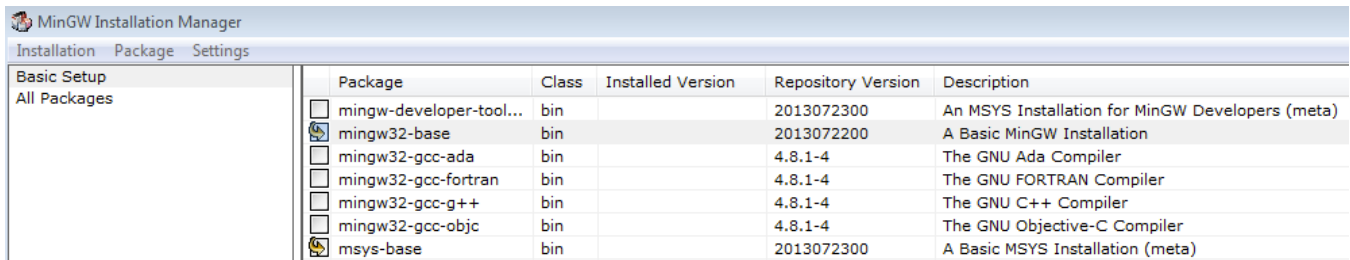

Figure 15. Set up MinGW and MSYS

- Click “Apply Changes” in the “Installation” menu and follow the remaining instructions to complete the installation.

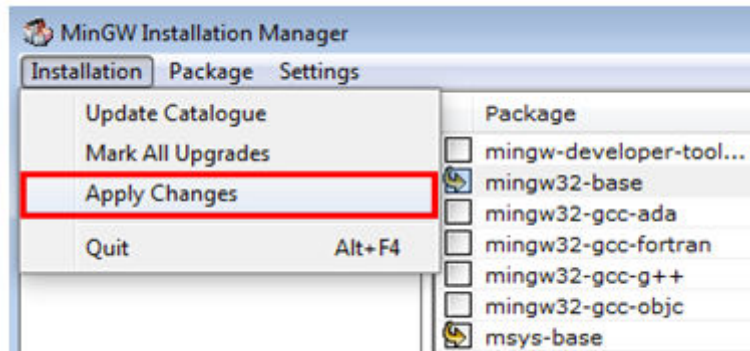

Figure 16. Complete MinGW and MSYS installation

- Add the appropriate item to the Windows operating system path environment variable. It can be found under *Control Panel -> System and Security -> System -> Advanced System Settings* in the "Environment Variables..." section. The path is:

`<mingw_install_dir>\bin`

Assuming the default installation path, C:\MinGW, an example is shown below. If the path is not set correctly, the toolchain does not work.

NOTE

If you have "C:\MinGW\msys\x.x\bin" in your PATH variable (as required by Kinetis SDK 1.0.0), remove it to ensure that the new GCC build system works correctly.

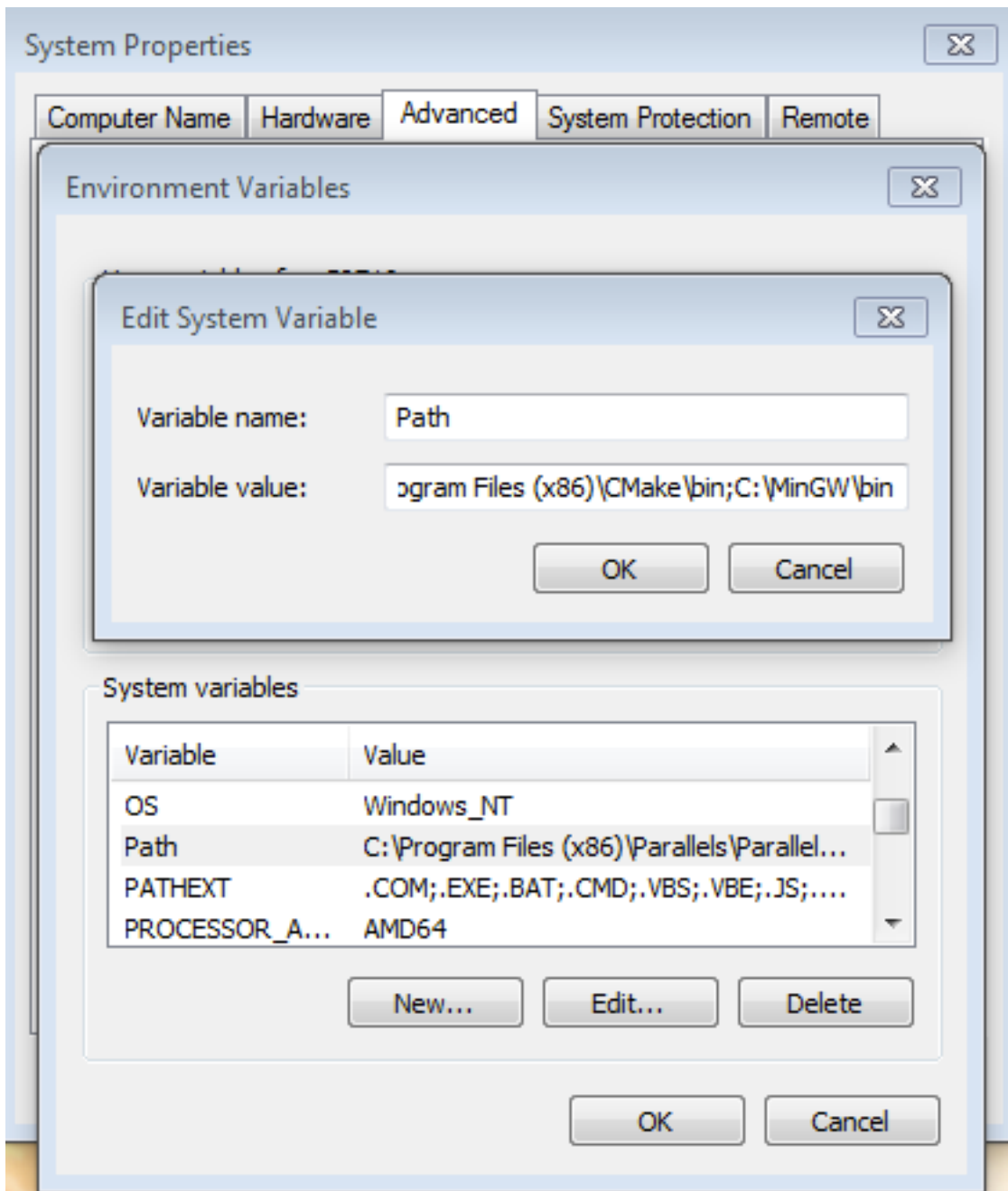

Figure 17. Add Path to systems environment

5.1.3 Add a new system environment variable for ARMGCC_DIR

Create a new *system* environment variable and name it ARMGCC_DIR. The value of this variable should point to the Arm GCC Embedded tool chain installation path. For this example, the path is:

Reference the installation folder of the GNU Arm GCC Embedded tools for the exact path name of your installation.

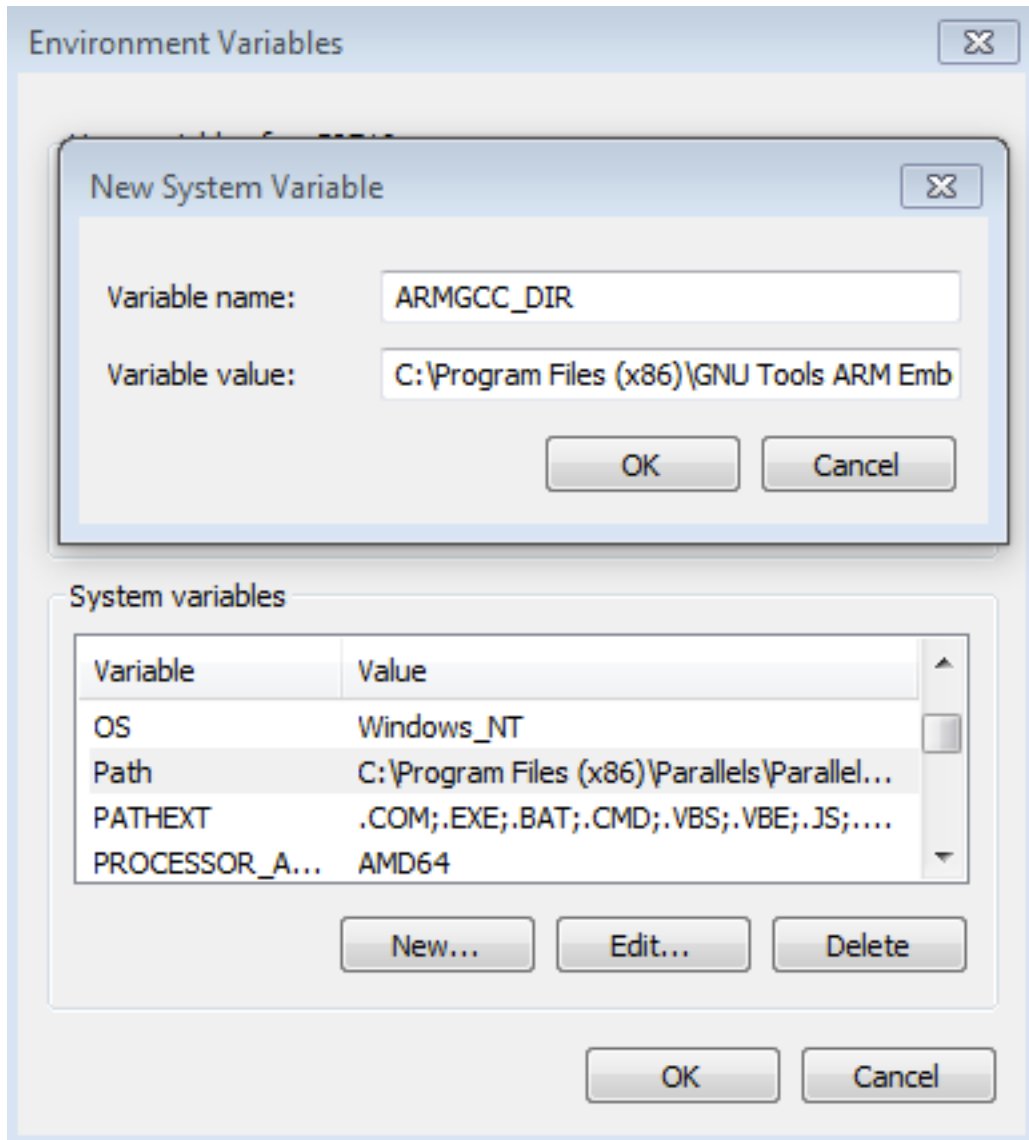

Figure 18. Add ARMGCC_DIR system variable

5.1.4 Install CMake

1. Download CMake 3.0.x from www.cmake.org/cmake/resources/software.html.
2. Install CMake, ensuring that the option "Add CMake to system PATH" is selected when installing. The user chooses to select whether it is installed into the PATH for all users or just the current user. In this example, it is installed for all users.

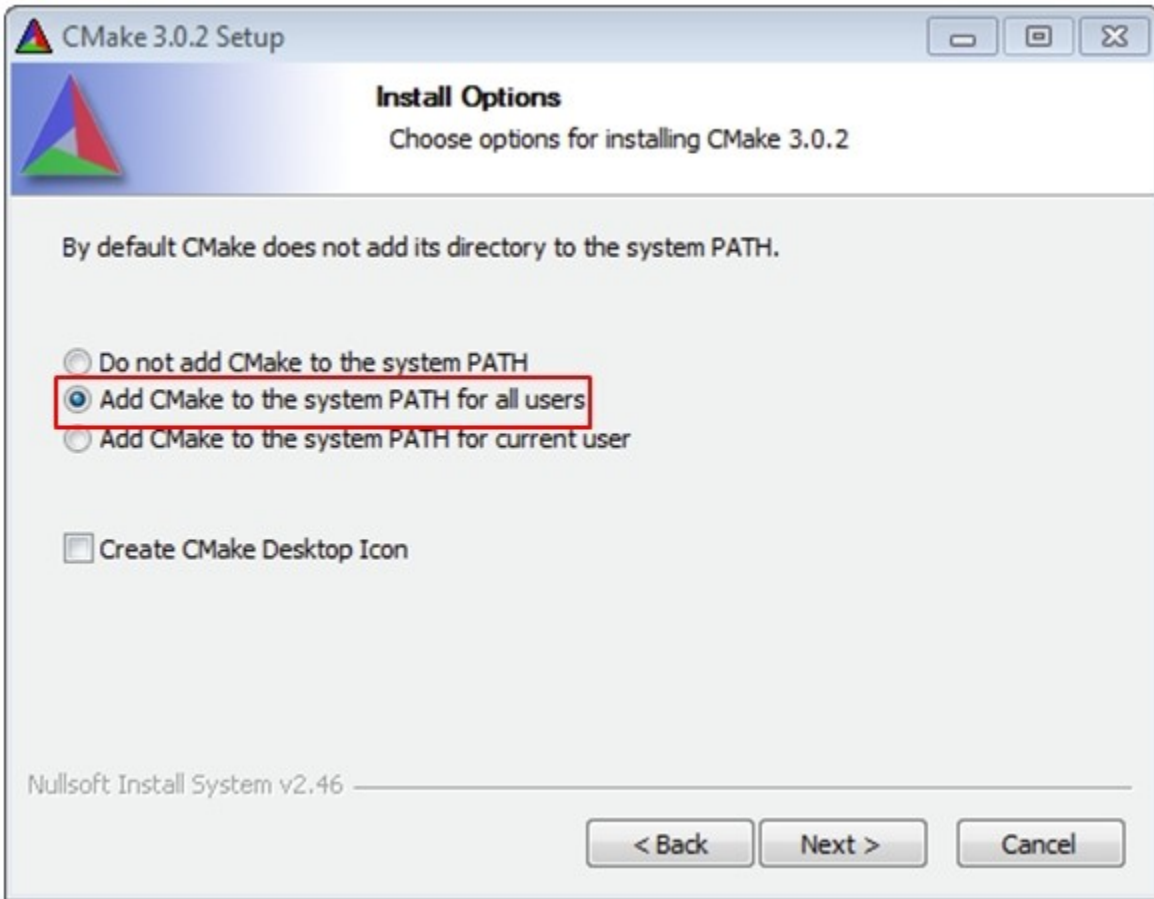

Figure 19. Install CMake

3. Follow the remaining instructions of the installer.
4. You may need to reboot your system for the PATH changes to take effect.
5. Make sure "sh.exe" is not in the Environment Variable PATH. This is a limitation of mingw32-make.

5.2 Build an example application

To build an example application, follow these steps.

1. Open a GCC Arm Embedded tool chain command window. To launch the window, from the Windows operating system Start menu, go to "Programs -> GNU Tools ARM Embedded <version>" and select "GCC Command Prompt".

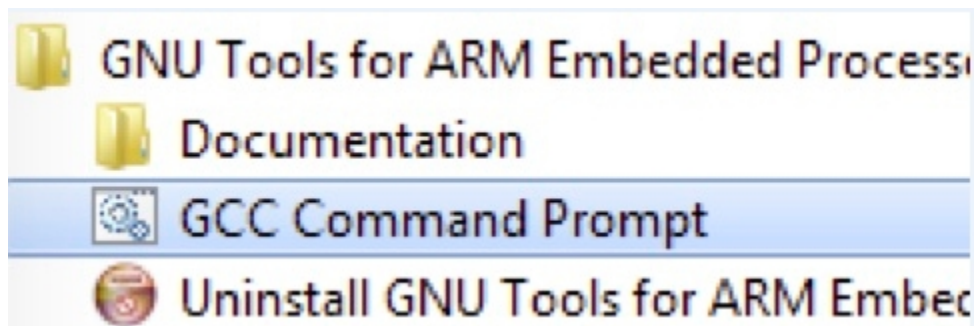

Figure 20. Launch command prompt

Run a demo using Arm® GCC

2. Change the directory to the example application project directory, which has a path similar to the following:

`<install_dir>/boards/<board_name>/<example_type>/<application_name>/armgcc`

For this example, the exact path is: `<install_dir>/examples/evkmimxrt1060/demo_apps/hello_world/armgcc`

NOTE

To change directories, use the 'cd' command.

3. Type “build_debug.bat” on the command line or double click on the "build_debug.bat" file in Windows Explorer to perform the build. The output is shown in this figure:

```
[ 95%] Building C object CMakeFiles/hello_world.elf.dir/C:/sdk_repo/mcu-sdk-2.0/boards/evkmimxrt1060/xip/evkmimxrt1060_sdram_ini_dcd.c.obj
[100%] Linking C executable debug\hello_world.elf
[100%] Built target hello_world.elf
C:\sdk_repo\mcu-sdk-2.0\boards\evkmimxrt1060\demo_apps\hello_world\armgcc>IF "" == "" (pause )
Press any key to continue . . .
```

Figure 21. hello_world demo build successful

5.3 Run an example application

This section describes steps to run a demo application using J-Link GDB Server application. To perform this exercise, two things must be done:

- Make sure that either:
 - The OpenSDA interface on your board is programmed with the J-Link OpenSDA firmware. If your board does not support OpenSDA, then a standalone J-Link pod is required.
 - You have a standalone J-Link pod that is connected to the debug interface of your board. Note that some hardware platforms require hardware modification in order to function correctly with an external debug interface.

After the J-Link interface is configured and connected, follow these steps to download and run the demo applications:

1. This board supports the J-Link debug probe. Before using it, install SEGGER software, which can be downloaded from <http://www.segger.com>
2. Connect the development platform to your PC via USB cable between the OpenSDA USB connector and the PC USB connector. If using a standalone J-Link debug pod, also connect it to the SWD/JTAG connector of the board.
3. Open the terminal application on the PC, such as PuTTY or TeraTerm, and connect to the debug serial port number (to determine the COM port number, see Appendix A). Configure the terminal with these settings:
 - a. 115200 or 9600 baud rate, depending on your board (reference BOARD_DEBUG_UART_BAUDRATE variable in board.h file)
 - b. No parity
 - c. 8 data bits
 - d. 1 stop bit

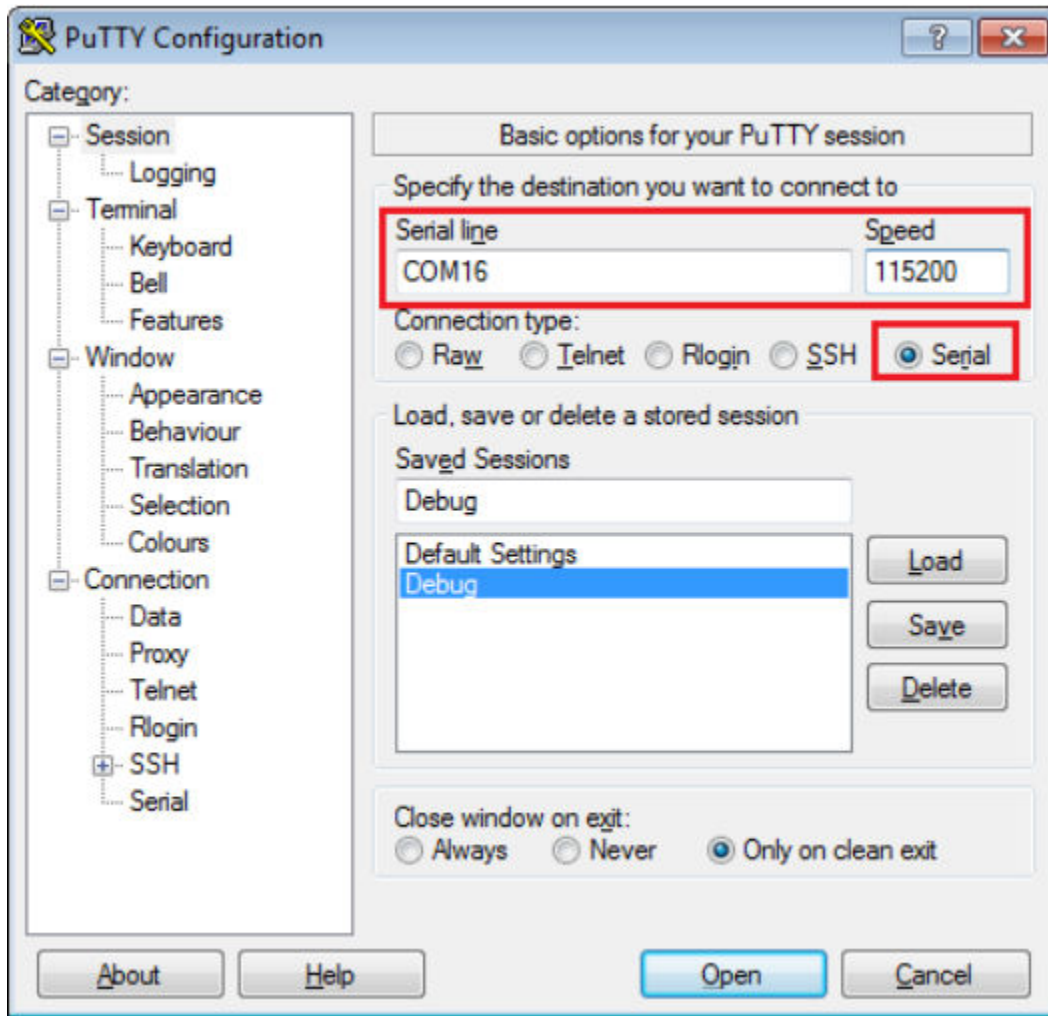

Figure 22. Terminal (PuTTY) configurations

4. Open the J-Link GDB Server application. Go to the SEGGER install folder, for example, C:\Program Files(x86)\SEGGER\JLink_Vxxx. Open the command windows here, for Debug and Release targets, and use the command "JLinkGDBServer.exe". sdrum_debug, sdrum_release, flexspi_nor_sdrum_debug, and flexspi_nor_sdrum_release targets, use the command "JLinkGDBServer.exe-scriptfile <install_dir>/boards/evkmimxrt1060/demo_apps/hello_world/evkmimxrt1060_sdrum_init.jlinkscript"
5. The target device selection chosen for this example is the MIMXRT1062DVL6A.
6. After it is connected, the screen should resemble this figure:

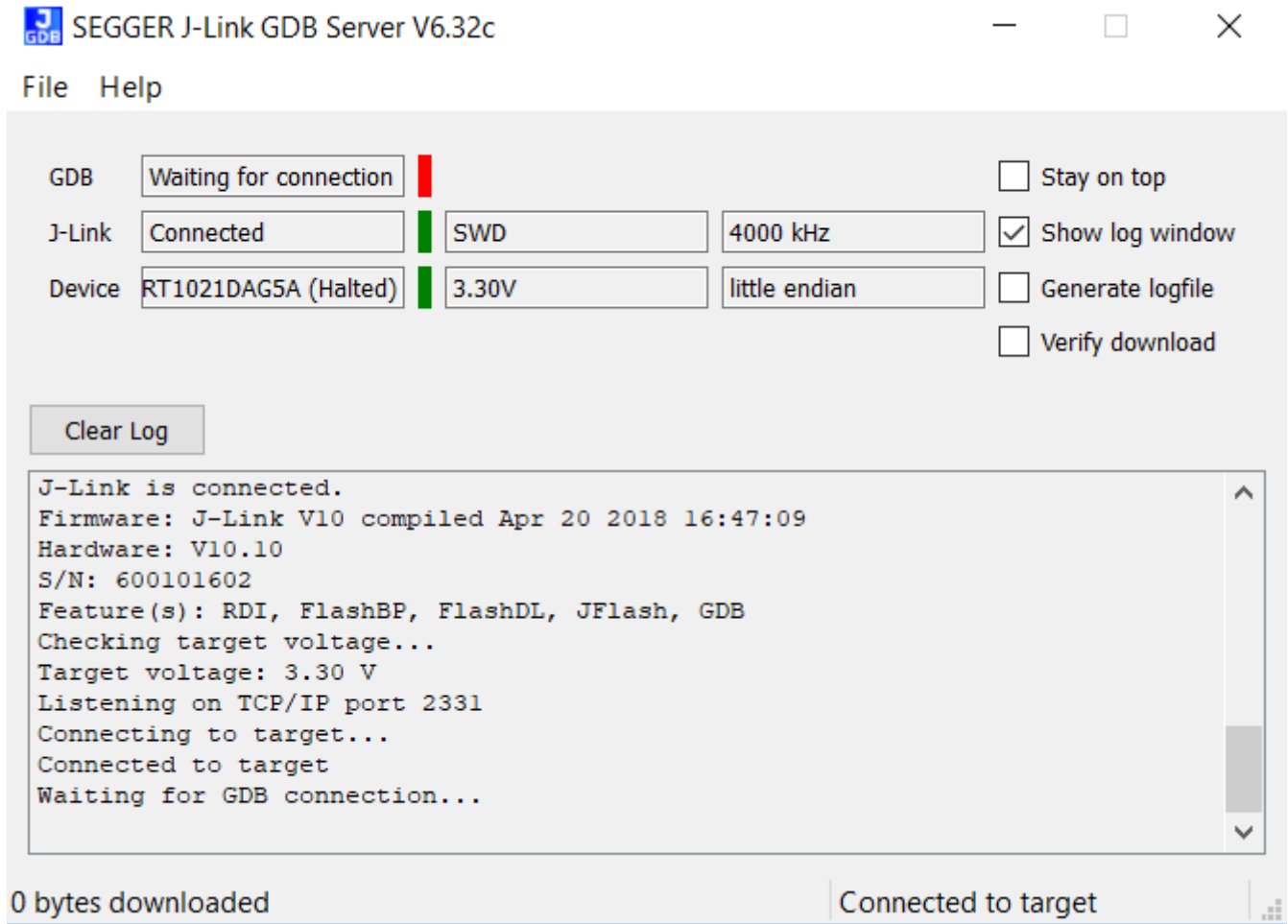

Figure 23. SEGGER J-Link GDB Server screen after successful connection

7. If not already running, open a GCC ARM Embedded tool chain command window. To launch the window, from the Windows operating system Start menu, go to “Programs -> GNU Tools ARM Embedded <version>” and select “GCC Command Prompt”.

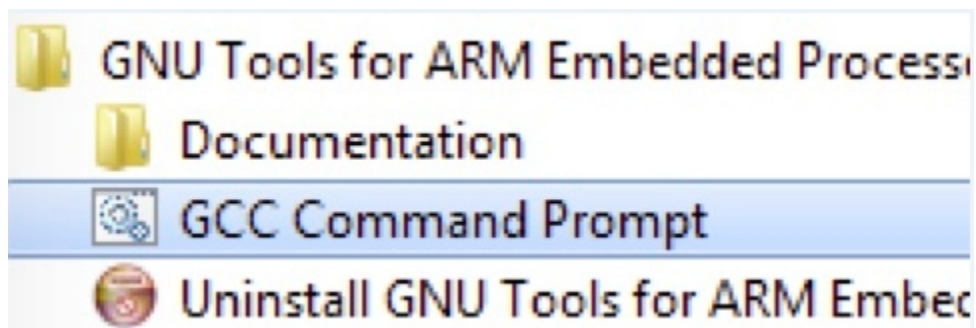

Figure 24. Launch command prompt

8. Change to the directory that contains the example application output. The output can be found in using one of these paths, depending on the build target selected:

`<install_dir>/boards/<board_name>/<example_type>/<application_name>/armgcc/debug`

`<install_dir>/boards/<board_name>/<example_type>/<application_name>/armgcc/release`

For this example, the path is:

```
<install_dir>/boards/evkmimxrt1060/demo_apps/hello_world/armgcc/debug
```

9. Run the command “arm-none-eabi-gdb.exe <application_name>.elf”. For this example, it is “arm-none-eabi-gdb.exe hello_world.elf”.

```

GCC Command Prompt - arm-none-eabi-gdb.exe C:\sdk_repo\mcu-sdk-2.0\boards\evkmimxrt1060\demo_apps\hello_world\ar...
C:\Program Files (x86)\GNU Tools Arm Embedded\7 2018-q2-update>cd bin
C:\Program Files (x86)\GNU Tools Arm Embedded\7 2018-q2-update\bin>arm-none-eabi-gdb.exe C:\sdk_repo\mcu-
sdk-2.0\boards\evkmimxrt1060\demo_apps\hello_world\armgcc\debug\hello_world.elf
GNU gdb (GNU Tools for Arm Embedded Processors 7-2018-q2-update) 8.1.0.20180315-git
Copyright (C) 2018 Free Software Foundation, Inc.
License GPLv3+: GNU GPL version 3 or later <http://gnu.org/licenses/gpl.html>
This is free software: you are free to change and redistribute it.
There is NO WARRANTY, to the extent permitted by law. Type "show copying"
and "show warranty" for details.
This GDB was configured as "--host=i686-w64-mingw32 --target=arm-none-eabi".
Type "show configuration" for configuration details.
For bug reporting instructions, please see:
<http://www.gnu.org/software/gdb/bugs/>.
Find the GDB manual and other documentation resources online at:
<http://www.gnu.org/software/gdb/documentation/>.
For help, type "help".
Type "apropos word" to search for commands related to "word"...
Reading symbols from C:\sdk_repo\mcu-sdk-2.0\boards\evkmimxrt1060\demo_apps\hello_world\armgcc\debug\hell
o_world.elf... done.
(gdb)

```

Figure 25. Run arm-none-eabi-gdb

10. Run these commands:
 - a. "target remote localhost:2331"
 - b. "monitor reset"
 - c. "monitor halt"
 - d. "load"
11. The application is now downloaded and halted at the reset vector. Execute the “monitor go” command to start the demo application.

The hello_world application is now running and a banner is displayed on the terminal. If this is not true, check your terminal settings and connections.

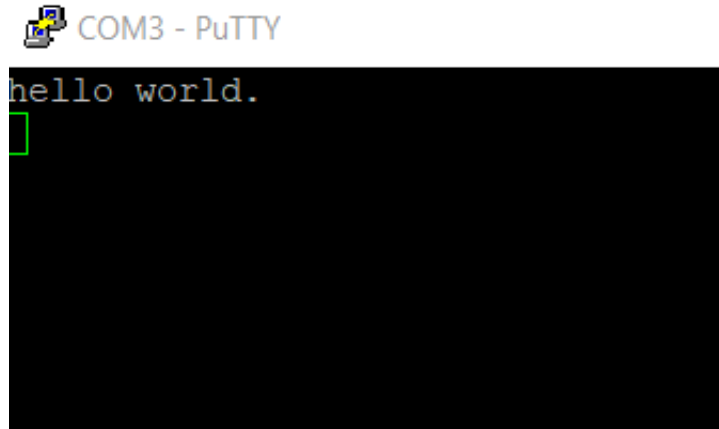

Figure 26. Text display of the hello_world demo

6 Run a demo using MCUXpresso IDE

NOTE

Ensure that the MCUXpresso IDE toolchain is included when generating the MCUXpresso SDK Package.

This section describes the steps required to configure MCUXpresso IDE to build, run, and debug example applications. The hello_world demo application targeted for the EVK-MIMXRT1060 platform is used as an example, though these steps can be applied to any example application in the MCUXpresso SDK.

NOTE

Three macros "XIP_EXTERNAL_FLASH=1", "XIP_BOOT_HEADER_ENABLE=1" and "XIP_BOOT_HEADER_DCD_ENABLE=1" are set by default in the project. If you do not use Board_Flash in the project, these macros should be removed or set value to 0 in project settings.

6.1 Select the workspace location

Every time MCUXpresso IDE launches, it prompts the user to select a workspace location. MCUXpresso IDE is built on top of Eclipse, which uses workspace to store information about its current configuration, and in some use cases, source files for the projects in the workspace. The location of the workspace can be anywhere, but it is recommended that the workspace be outside of the MCUXpresso SDK tree.

6.2 Build an example application

To build an example application, follow these steps.

1. Drag and drop the SDK zip file into the "Installed SDKs" view to install the MCUXpresso SDK. In the window that appears, click the "OK" button and wait until the import has finished.

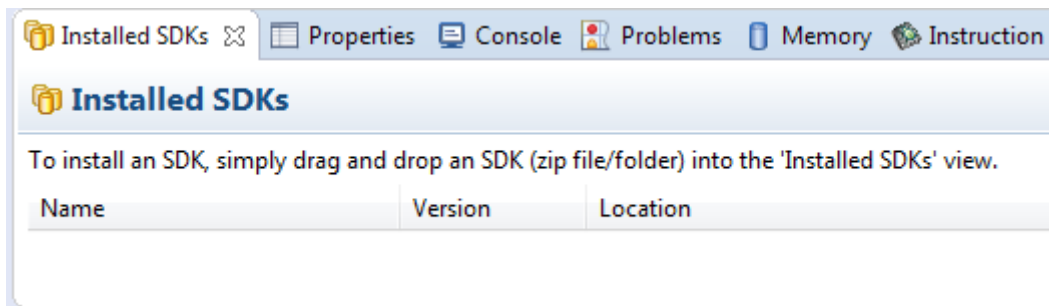

Figure 27. Install an SDK

2. On the *Quickstart Panel*, click “Import SDK example(s)...”.

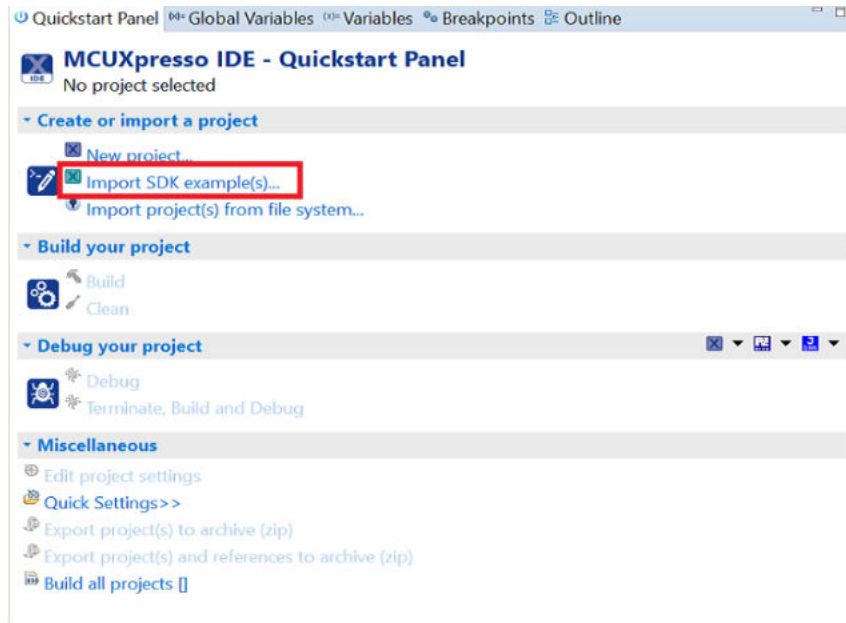

Figure 28. Import an SDK example

3. In the window that appears, expand the “MIMXRT1060” folder and select “MIMXRT1062xxxx”. Then, select “evkmimxrt1060” and click the “Next” button.

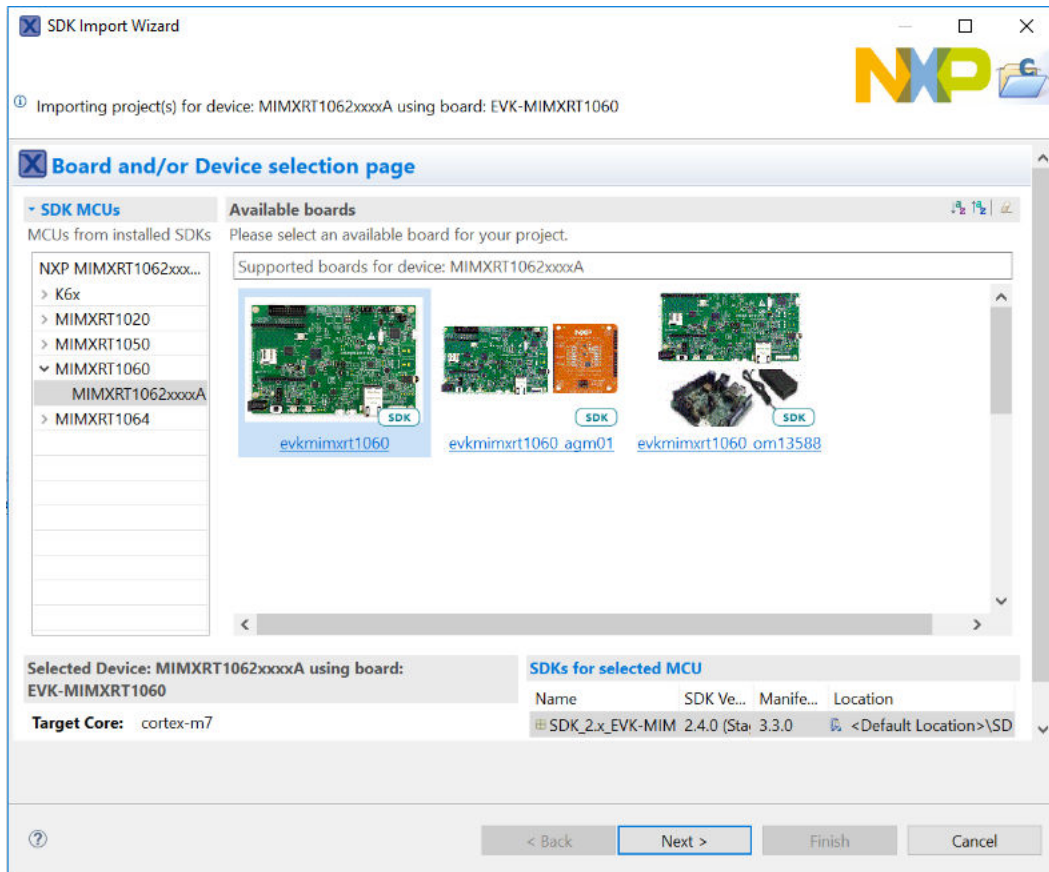

Figure 29. Select EVK-MIMXRT1060 board

4. Expand the “demo_apps” folder and select “hello_world”. Then, click the "Next" button.

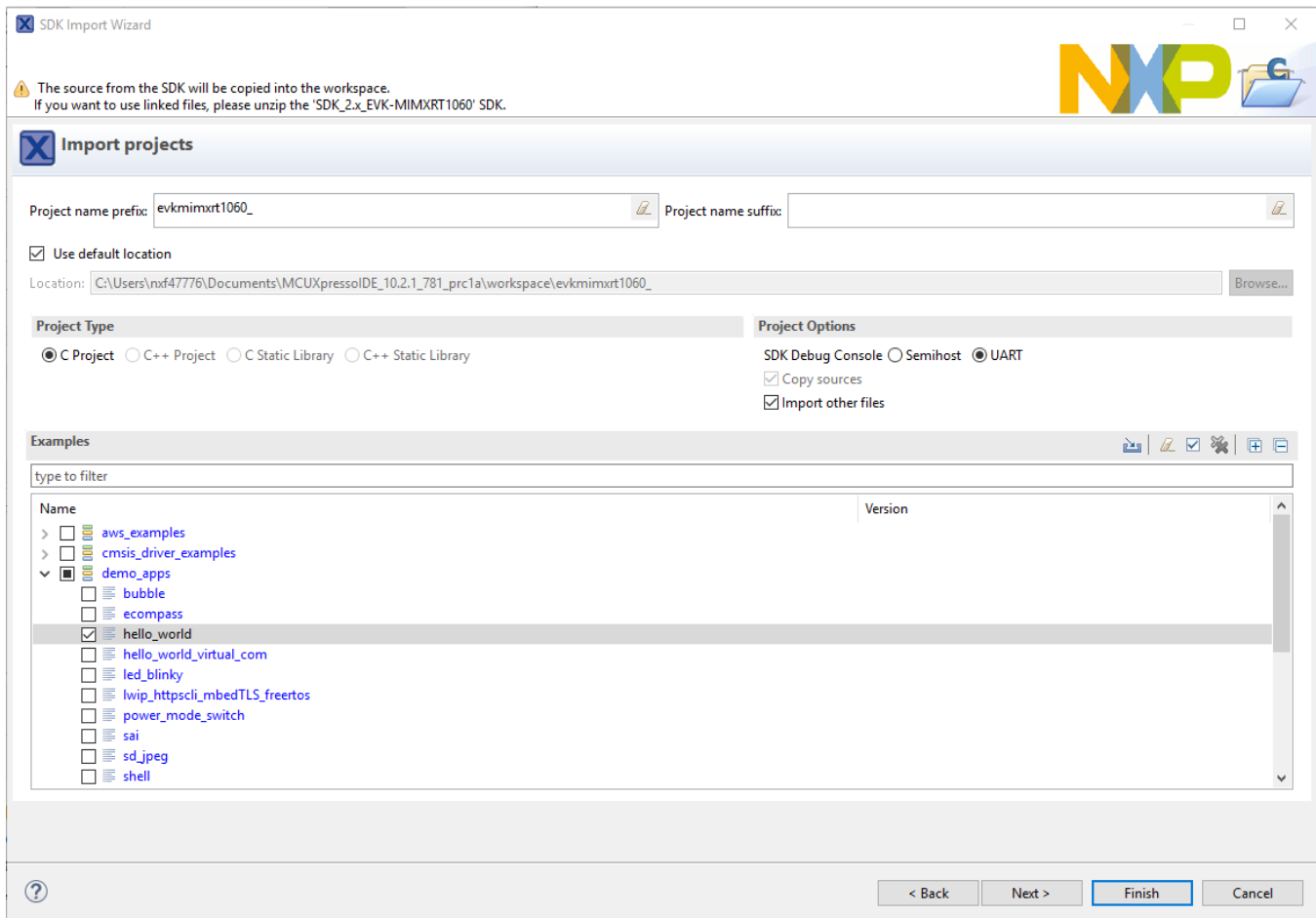

Figure 30. Select "hello_world"

5. Ensure the option “Redlib: Use floating point version of printf” is selected if the cases print floating point numbers on the terminal (for demo applications such as dac32_adc12, dac_adc, dac_cadc, ecompass, sai, coremark, mbedtls_benchmark, wolfssl_benchmark, and for mmcau_examples such as mmcau_api). Otherwise, there is no need to select it. Click the “Finish” button.

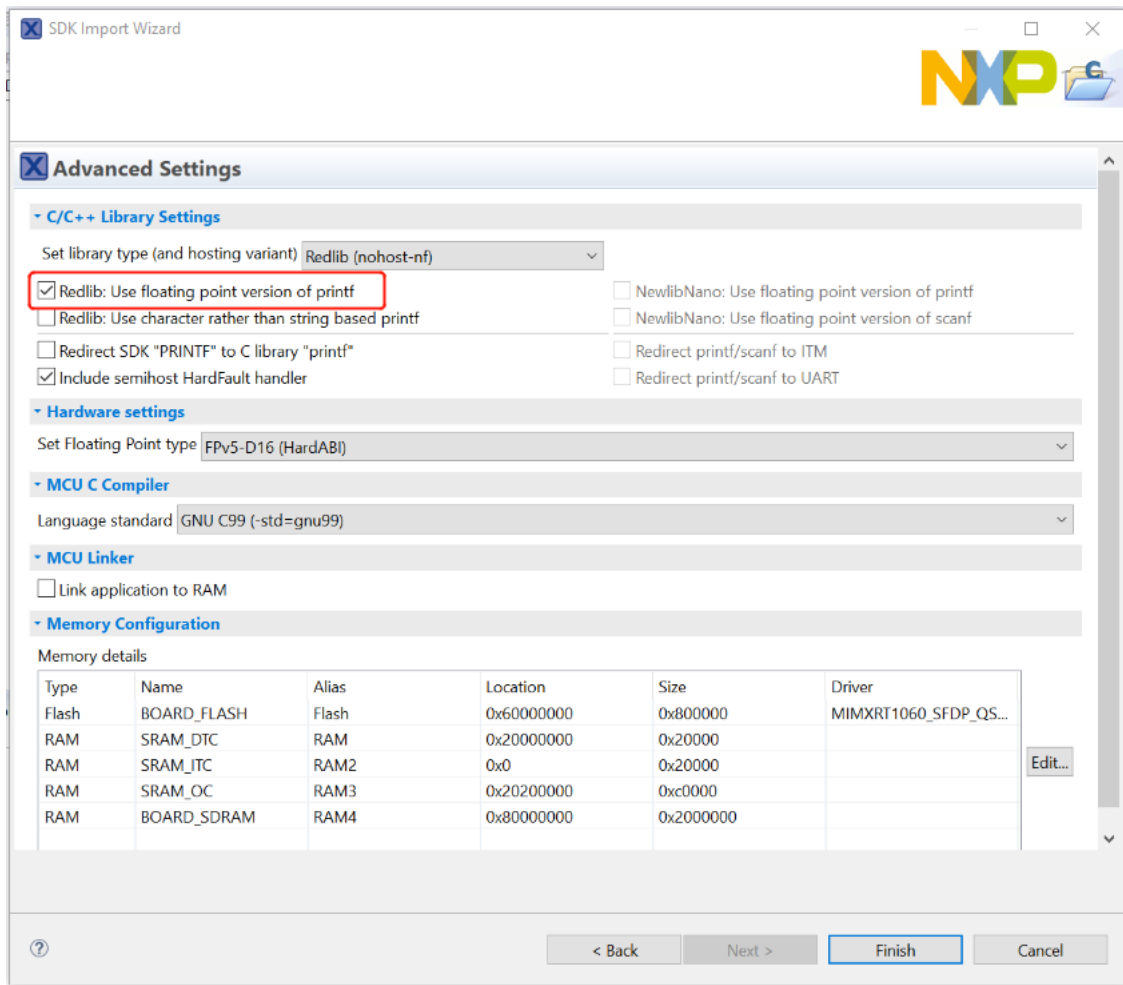

Figure 31. Select "User floating print version of printf"

NOTE

If you want to use semihost to print log, first select the "Semihost" button when importing projects. Then, change the value of "SDK_DEBUGCONSOLE" from "1" to "0" in Properties.

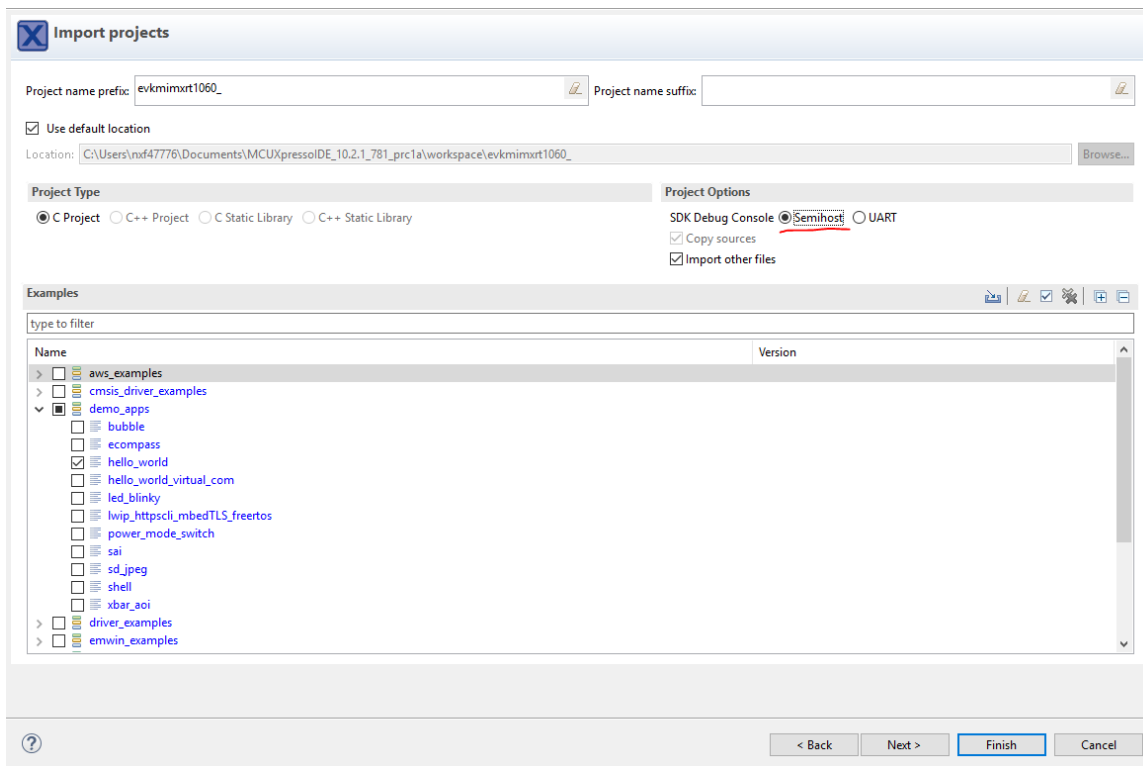

Figure 32. Select "Semihost"

Run a demo using MCUXpresso IDE

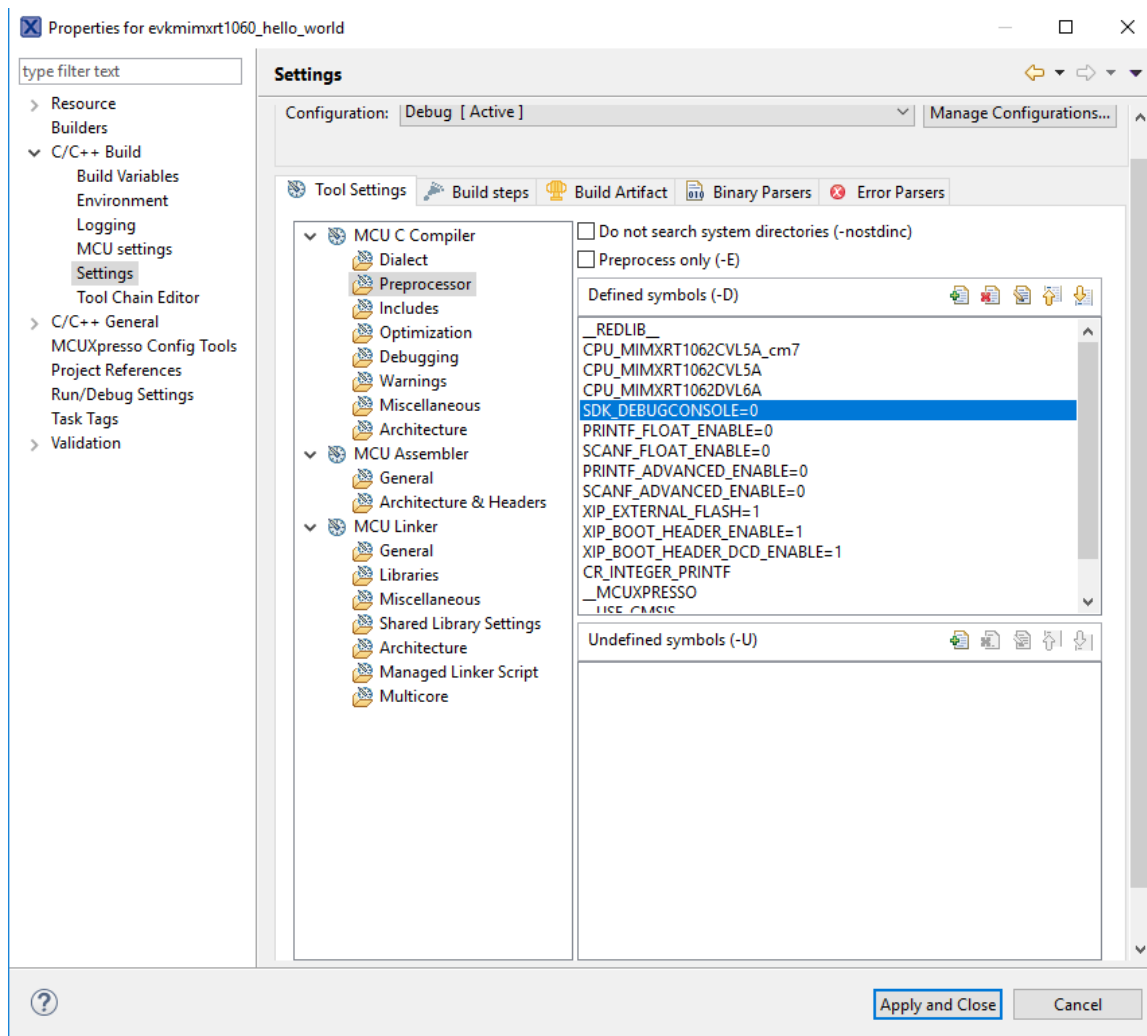

Figure 33. Setting "SDK_DEBUGCONSOLE"

6. On the *Quickstart Panel*, click "'build evkmimxrt1060_demo_apps_hello_world' [Debug]".

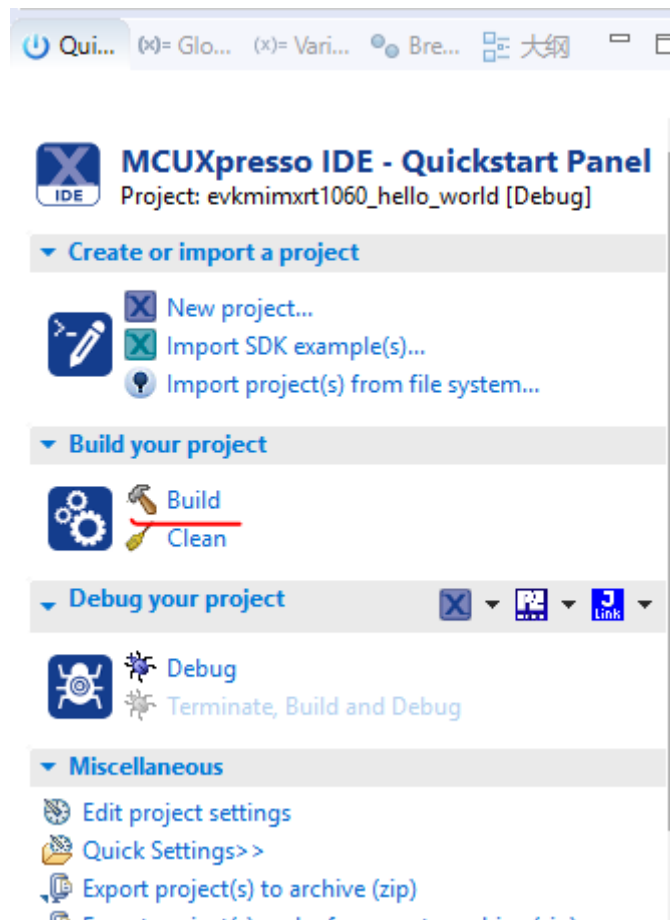

Figure 34. Build hello world case

6.3 Run an example application

For more information on debug probe support in the MCUXpresso IDE, visit community.nxp.com.

To download and run the application, perform these steps:

NOTE

Make sure that the board is on QSPI_Flash mode before download (set SW8: 0010).

1. On the *Quickstart Panel*, click on "'Debug evkmimxrt1060_demo_apps_hello_world' [Debug]".

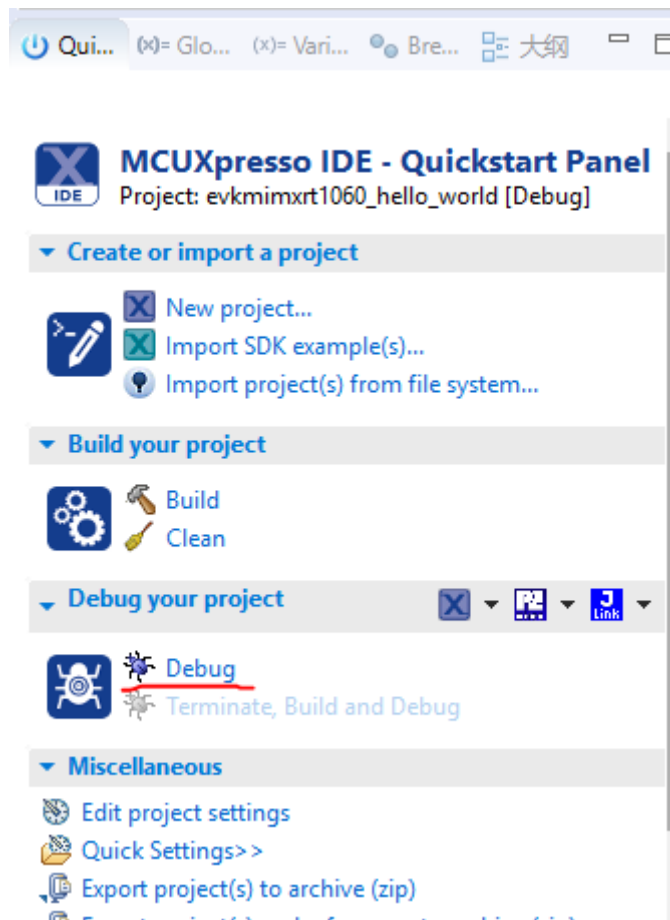

Figure 35. Debug "hello_world" case

2. The first time you debug a project, the Debug Emulator Selection Dialog is displayed, showing all supported probes that are attached to your computer. Select the probe through which you want to debug and click the “OK” button. (For any future debug sessions, the stored probe selection is automatically used, unless the probe cannot be found.)

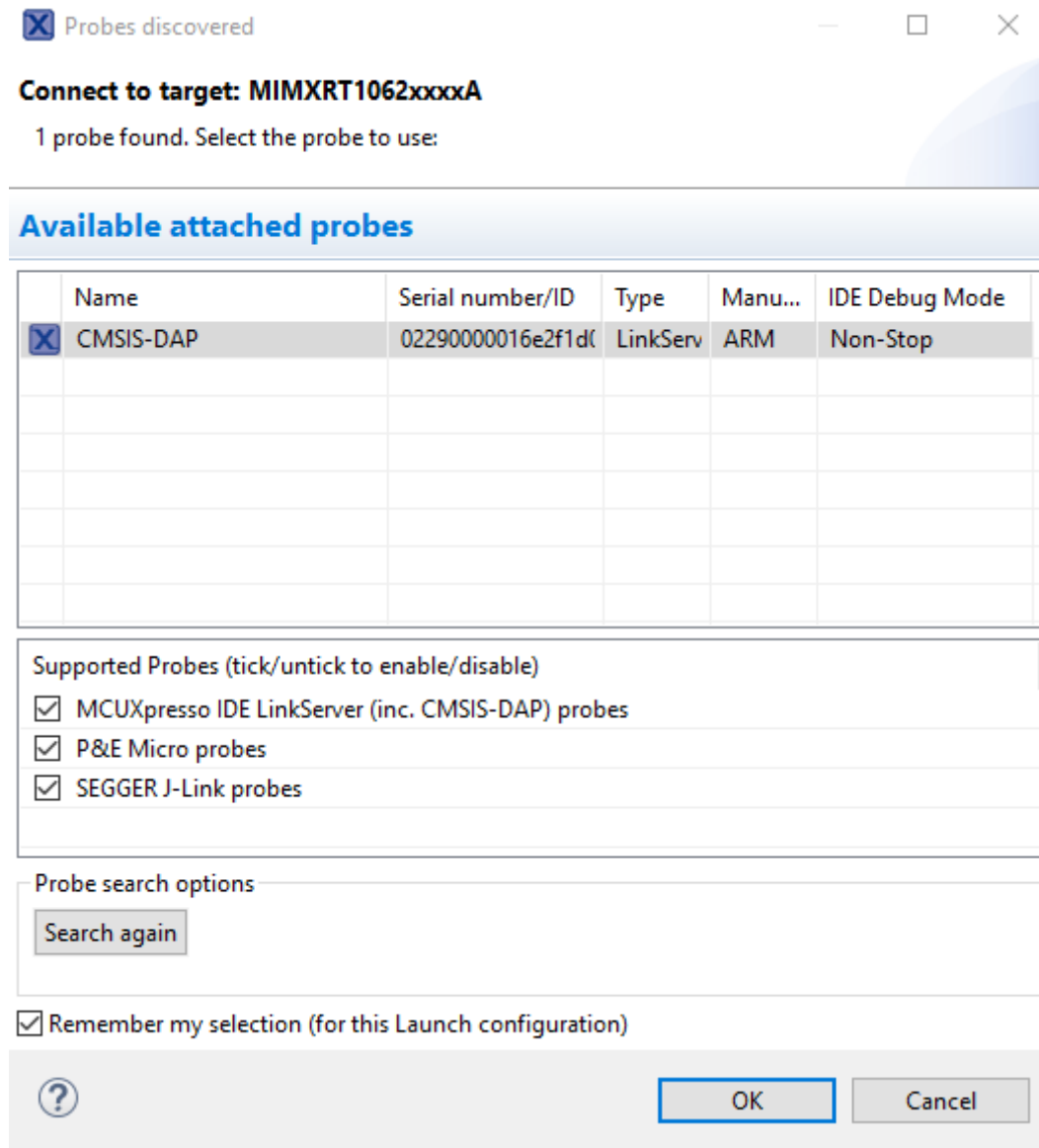

Figure 36. Attached Probes: debug emulator selection

3. The application is downloaded to the target and automatically runs to main():

Run a demo using MCUXpresso IDE

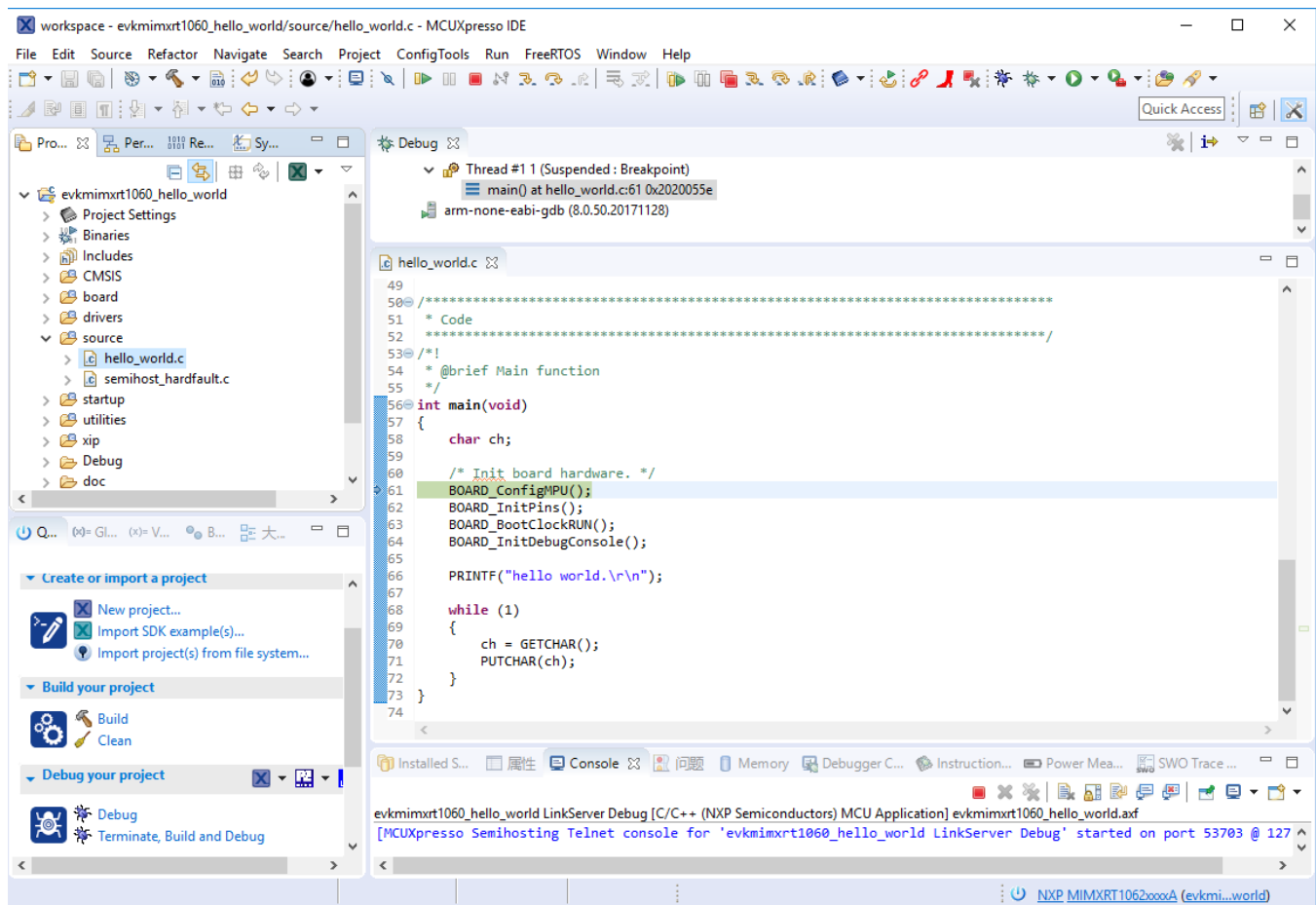

Figure 37. Stop at main() when running debugging

4. Start the application by clicking the "Resume" button.

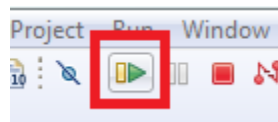

Figure 38. Resume button

The hello_world application is now running and a banner is displayed on the MCUXpresso IDE console window. If this is not the case, check your terminal settings and connections.

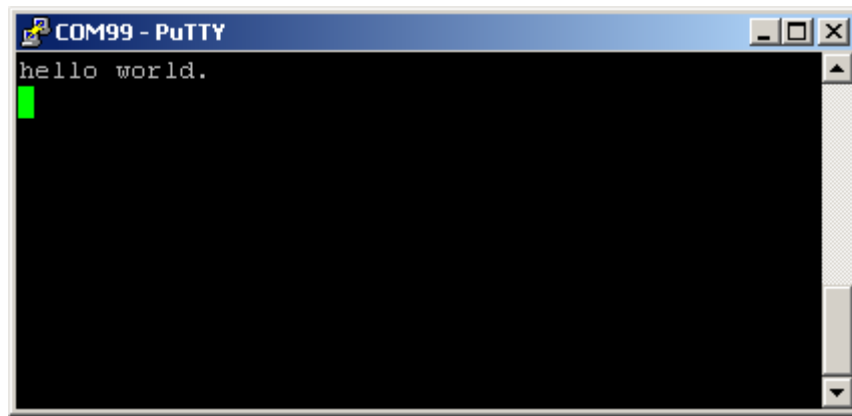





Figure 39. Text display of the hello_world demo

7 MCUXpresso Config Tools

MCUXpresso Config Tools can help configure the processor and generate initialization code for the on chip peripherals. The tools are able to modify any existing example project, or create a new configuration for the selected board or processor. The generated code is designed to be used with MCUXpresso SDK version 2.x.

The MCUXpresso Config Tools consist of the following:

Table 1. MCUXpresso Config Tools

Config Tool	Description	Image
Pins tool	For configuration of pin routing and pin electrical properties.	
Clock tool	For system clock configuration	
Peripherals tools	For configuration of other peripherals	
Project Cloner	Allows creation of standalone projects from MCUXpresso SDK examples.	

MCUXpresso Config Tools can be accessed in the following products:

- **Integrated** in the MCUXpresso IDE. Config tools are integrated with the compiler and debugger, so this represents the easiest way to begin that development.
- **Standalone version** available for download from www.nxp.com. Recommended for customers using IAR Embedded Workbench, Keil MDK μ Vision, or Arm GCC.
- **Online version** available on mcuxpresso.nxp.com. Recommended to do a quick evaluation of the processor or use the tool without installation.

Each version of the product contains a specific “Quick Start Guide” document that can help start your work.

8 MCUXpresso IDE New Project Wizard

MCUXpresso IDE features a new project wizard. The wizard provides functionality for the user to create new projects from the installed SDKs (and from pre-installed part support), offers the flexibility to select/change many builds, includes a library, and provides source code options. The source code is organized as software components, categorized as driver, utilities, and middleware.

To use the wizard, start the MCUXpresso IDE. This is located in the *QuickStart Panel* at the bottom left of the MCUXpresso IDE window. Select the “New project” option, shown in the below figure.



Figure 40. MCUXpresso IDE Quickstart Panel

For more details of the usage of new project wizard, see the “MCUXpresso_IDE_User_Guide.pdf” in the MCUXpresso IDE installation folder.

9 Appendix A - How to determine COM port

This section describes the steps necessary to determine the debug COM port number of your NXP hardware development platform.

1. **Linux:** The serial port can be determined by running the following command after the USB Serial is connected to the host:

```
$ dmesg | grep "ttyUSB"
[503175.307873] usb 3-12: cp210x converter now attached to ttyUSB0
[503175.309372] usb 3-12: cp210x converter now attached to ttyUSB1
```

There are two ports, one is Cortex-A core debug console, another is for Cortex M4.

2. **Windows:** To determine the COM port, open the Windows operating system Device Manager. This can be achieved by going to the Windows operating system Start menu and typing “Device Manager” in the search bar, as shown below:

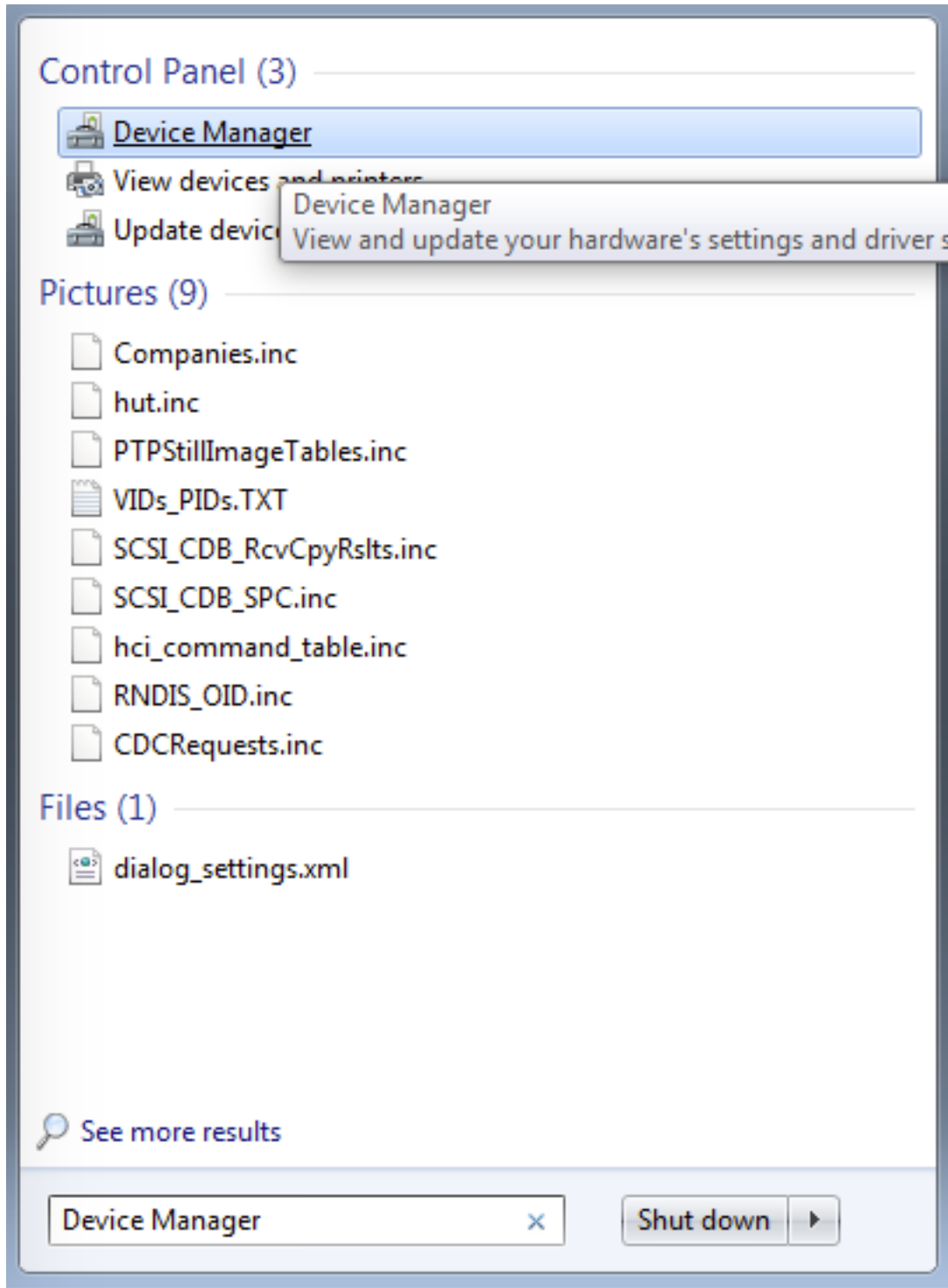

Figure 41. Device Manager

3. In the Device Manager, expand the “Ports (COM & LPT)” section to view the available ports. Depending on the NXP board you’re using, the COM port can be named differently:

10 Appendix B - How to add or remove boot header for XIP targets

The MCUXpresso SDK for i.MX RT1060 provides flexspi_nor_debug and flexspi_nor_release targets for each example and/or demo which supports XIP (eXecute-In-Place). These two targets add XIP_BOOT_HEADER to the image by default. Because of this, ROM can boot and run this image directly on external flash.

Macros for the boot leader:

- The following three macros are added in flexspi_nor targets to support XIP.

Table 2. Macros added in flexspi_nor

XIP_EXTERNAL_FLASH	1: Exclude the code which changes the clock of FLEXSPI.
	0: Make no changes.
XIP_BOOT_HEADER_ENABLE	1: Add FLEXSPI configuration block, image vector table, boot data, and device configuration data (optional) to the image by default.
	0: Add nothing to the image by default.
XIP_BOOT_HEADER_DCD_ENABLE	1: Add device configuration data to the image.
	0: Do NOT add device configuration data to the image.

- The following table shows the different effect on the built image with a different combination of these macros:

Table 3. Effects on built image with different macros

		XIP_BOOT_HEADER_DCD_ENABLE=1	XIP_BOOT_HEADER_DCD_ENABLE=0
XIP_EXTERNAL_FLASH=1	XIP_BOOT_HEADER_ENABLE=1	<ul style="list-style-type: none"> Can be programmed to qspi flash by IDE and can run after POR reset if qspi flash is the boot source. SDRAM will be initialized. 	<ul style="list-style-type: none"> Can be programmed to qspi flash by IDE, and can run after POR reset if qspi flash is the boot source. SDRAM will NOT be initialized.
	XIP_BOOT_HEADER_ENABLE=0	<ul style="list-style-type: none"> CANNOT run after POR reset if it is programmed by 	

Table continues on the next page...

Table 3. Effects on built image with different macros (continued)

		IDE, even if qspiflash is the boot source.
XIP_EXTERNAL_FLASH=0		<ul style="list-style-type: none"> This image CANNOT complete XIP because when this macro is set to 1, it excludes the code, which changes the clock for FLEXSPI.

• Where to change the macros for each toolchain in MCUXpresso SDK?

Take hello_world as an example:

IAR:

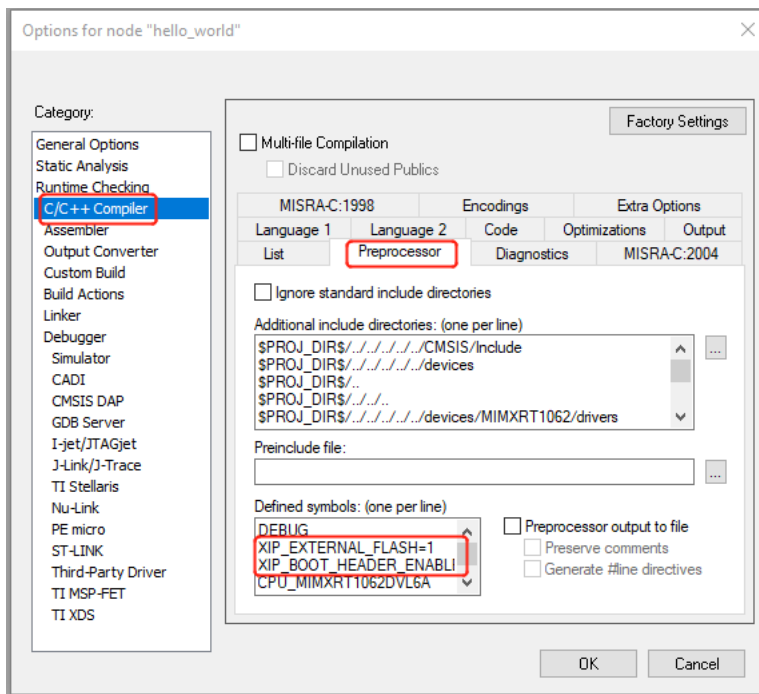

Figure 42. Options node IAR

MDK:

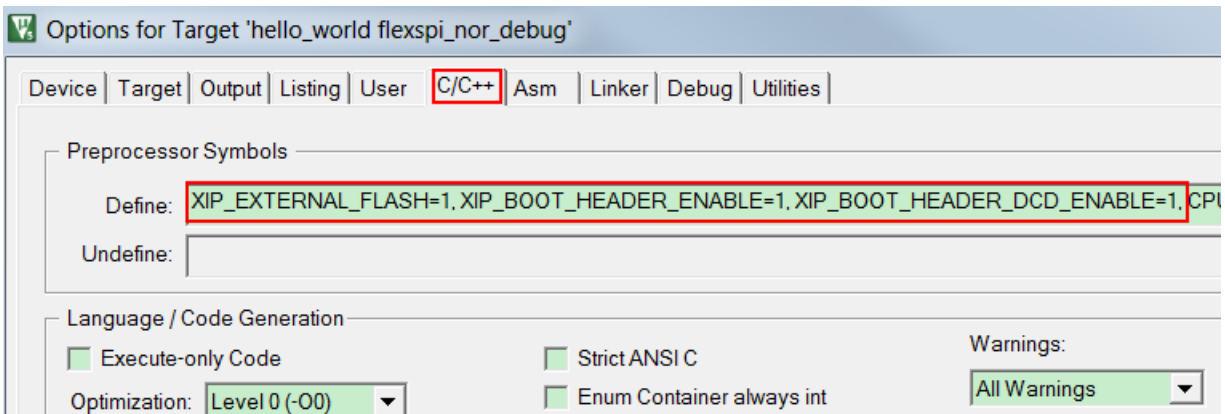

Figure 43. Options for target

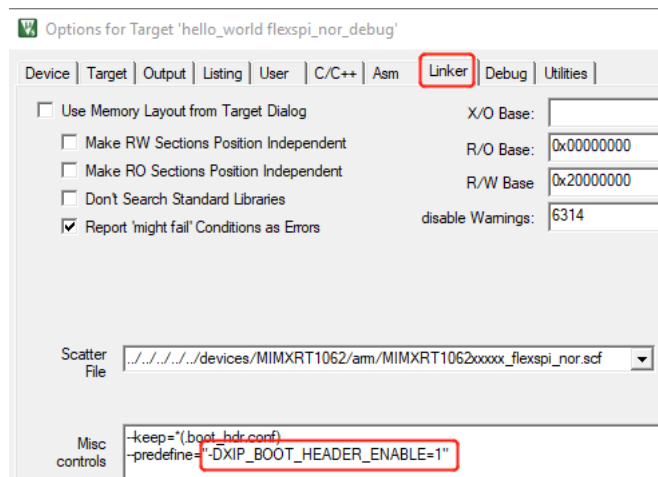

Figure 44. Change configuration Misc controls

ARMGCC:

Change the configuration in CMakeLists.txt.

```

SET(CMAKE_C_FLAGS_SDRAM_RELEASE "${CMAKE_C_FLAGS_SDRAM_RELEASE} -std=gnu99")
SET(CMAKE_C_FLAGS_FLEXSPI_NOR_DEBUG "${CMAKE_C_FLAGS_FLEXSPI_NOR_DEBUG} -DXIP_EXTERNAL_FLASH=1")
SET(CMAKE_C_FLAGS_FLEXSPI_NOR_DEBUG "${CMAKE_C_FLAGS_FLEXSPI_NOR_DEBUG} -DXIP_BOOT_HEADER_ENABLE=1")
SET(CMAKE_C_FLAGS_FLEXSPI_NOR_DEBUG "${CMAKE_C_FLAGS_FLEXSPI_NOR_DEBUG} -DXIP_BOOT_HEADER_DCD_ENABLE=1")
SET(CMAKE_C_FLAGS_FLEXSPI_NOR_DEBUG "${CMAKE_C_FLAGS_FLEXSPI_NOR_DEBUG} -DCPU_MIMXRT1052DVL6A")
    
```

Figure 45. Change configuration CMakeLists.txt

MCUX:

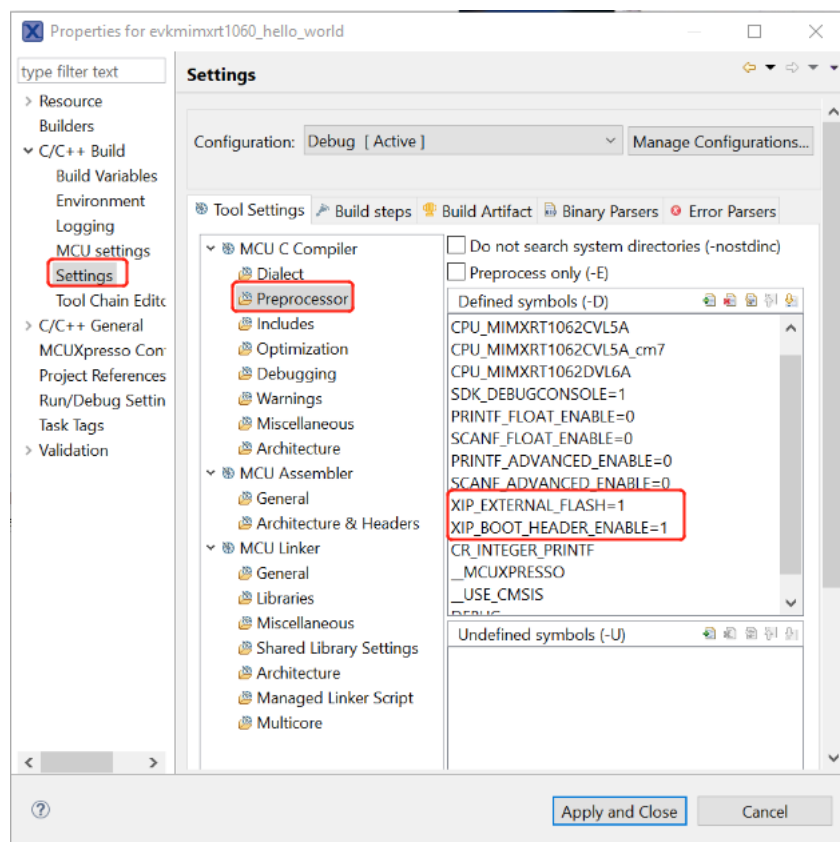

Figure 46. Properties for evkmimxrt1060

11 Revision history

This table summarizes revisions to this document.

Table 4. Revision history

Revision number	Date	Substantive changes
0	08/2018	Initial release
1	06/2019	Updates for MCUXpresso SDK v2.6.0

How to Reach Us:**Home Page:**nxp.com**Web Support:**nxp.com/support

Information in this document is provided solely to enable system and software implementers to use NXP products. There are no express or implied copyright licenses granted hereunder to design or fabricate any integrated circuits based on the information in this document. NXP reserves the right to make changes without further notice to any products herein.

NXP makes no warranty, representation, or guarantee regarding the suitability of its products for any particular purpose, nor does NXP assume any liability arising out of the application or use of any product or circuit, and specifically disclaims any and all liability, including without limitation consequential or incidental damages. "Typical" parameters that may be provided in NXP data sheets and/or specifications can and do vary in different applications, and actual performance may vary over time. All operating parameters, including "typicals," must be validated for each customer application by customer's technical experts. NXP does not convey any license under its patent rights nor the rights of others. NXP sells products pursuant to standard terms and conditions of sale, which can be found at the following address: nxp.com/SalesTermsandConditions.

While NXP has implemented advanced security features, all products may be subject to unidentified vulnerabilities. Customers are responsible for the design and operation of their applications and products to reduce the effect of these vulnerabilities on customer's applications and products, and NXP accepts no liability for any vulnerability that is discovered. Customers should implement appropriate design and operating safeguards to minimize the risks associated with their applications and products.

NXP, the NXP logo, NXP SECURE CONNECTIONS FOR A SMARTER WORLD, COOLFLUX, EMBRACE, GREENCHIP, HITAG, I2C BUS, ICODE, JCOP, LIFE VIBES, MIFARE, MIFARE CLASSIC, MIFARE DESFire, MIFARE PLUS, MIFARE FLEX, MANTIS, MIFARE ULTRALIGHT, MIFARE4MOBILE, MIGLO, NTAG, ROADLINK, SMARTLX, SMARTMX, STARPLUG, TOPFET, TRENCHMOS, UCODE, Freescale, the Freescale logo, AltiVec, C-5, CodeTEST, CodeWarrior, ColdFire, ColdFire+, C-Ware, the Energy Efficient Solutions logo, Kinetis, Layerscape, MagniV, mobileGT, PEG, PowerQUICC, Processor Expert, QorIQ, QorIQ Qonverge, Ready Play, SafeAssure, the SafeAssure logo, StarCore, Symphony, VortiQa, Vybrid, Airfast, BeeKit, BeeStack, CoreNet, Flexis, MXC, Platform in a Package, QUICC Engine, SMARTMOS, Tower, TurboLink, and UMEMS are trademarks of NXP B.V. All other product or service names are the property of their respective owners. AMBA, Arm, Arm7, Arm7TDMI, Arm9, Arm11, Artisan, big.LITTLE, Cordio, CoreLink, CoreSight, Cortex, DesignStart, DynamIQ, Jazelle, Keil, Mali, Mbed, Mbed Enabled, NEON, POP, RealView, SecurCore, Socrates, Thumb, TrustZone, ULINK, ULINK2, ULINK-ME, ULINK-PLUS, ULINKpro, μ Vision, Versatile are trademarks or registered trademarks of Arm Limited (or its subsidiaries) in the US and/or elsewhere. The related technology may be protected by any or all of patents, copyrights, designs and trade secrets. All rights reserved. Oracle and Java are registered trademarks of Oracle and/or its affiliates. The Power Architecture and Power.org word marks and the Power and Power.org logos and related marks are trademarks and service marks licensed by Power.org.

© 2019 NXP B.V.

Document Number MCUXSDKMIMXRT106XGSUG
Revision 1, 06/2019

