

UM11423

LPCXpresso55S16 Development Boards

Rev. 1.3 — 20 October 2020

User manual

Document information

Info	Content
Keywords	LPC55S16, LPC55S1x, LPCXpresso55S16, LPC55S16-EVK
Abstract	LPCXpresso55S16 development board user manual



Revision history

Rev	Date	Description
1.3	20201019	Updated description of JP12 to include an explanation of establishing an external USART connection using JP3. Corrected miscellaneous typos.
1.2	20200619	Added Section 10.2 “Proper termination resistors required between the MCU and the USB connector” .
1.1	20200306	Updated information about crystals. Updated information about 1.8V operation. Added clarifications about labeling of external serial connector. Added section 10 to Errata. Added information about regulator errata.
1.0	20201002	Initial internal release.

Contact information

For more information, please visit: <http://www.nxp.com>

For sales office addresses, please send an email to: salesaddresses@nxp.com

1. Introduction

The LPCXpresso™ family of boards provides a powerful and flexible development system for NXP's LPC Cortex®-M family of MCUs. They can be used with a wide range of development tools, including NXP's MCUXpresso IDE, Keil uVISION and IAR Embedded Workbench. The LPCXpresso55S06 board (order code LPC55S06-EVK) is the evaluation and development platform for the LPC55S1x families of MCUs.

See <https://www.nxp.com/demoboard/LPC55S06-EVK> for more information on these boards, including tutorial videos, development software and board hardware design files. The abbreviation LPC55S1x is used to collectively refer to the LPC55S16 family device on the board.

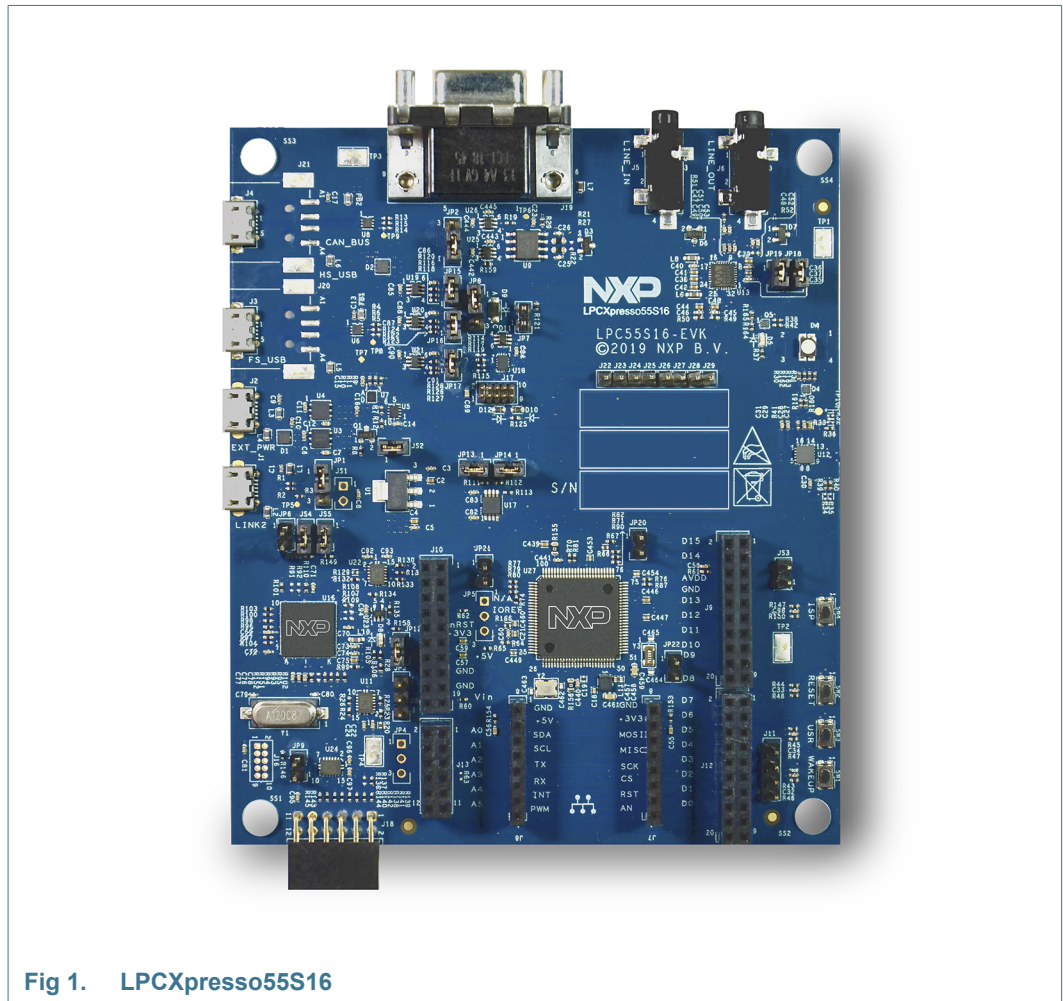

Fig 1. LPCXpresso55S16

The LPCXpresso55S16 board includes the following features:

- LPC55S16 Cortex-M33 processor
- Onboard, high-speed USB, Link2 debug probe with CMSIS-DAP and SEGGER J-Link protocol options

- UART and SPI port bridging from LPC55Sxx target to USB via the onboard debug probe
- Optional external debug probes with trace option (10 or 20 pin Cortex-M connectors)
- External crystal oscillators
- RGB user LED
- Reset, ISP, User/Wakeup and user buttons
- Multiple Expansion options, including Arduino UNO, Mikroe Click and PMod
- CAN-FD controller and onboard CAN transceiver
- NXP FXOS8700 accelerometer
- Stereo audio codec with line in/out
- High / full speed USB port with micro A/B connector for the host or device functionality

2. Board layout and Settings

Figure 2 shows the layout of the board (top side), indicating the default location of the jumpers, while Figure 3 shows locations of the connectors and headers. Table 1 provides a description of connectors, jumpers, LEDs and buttons.

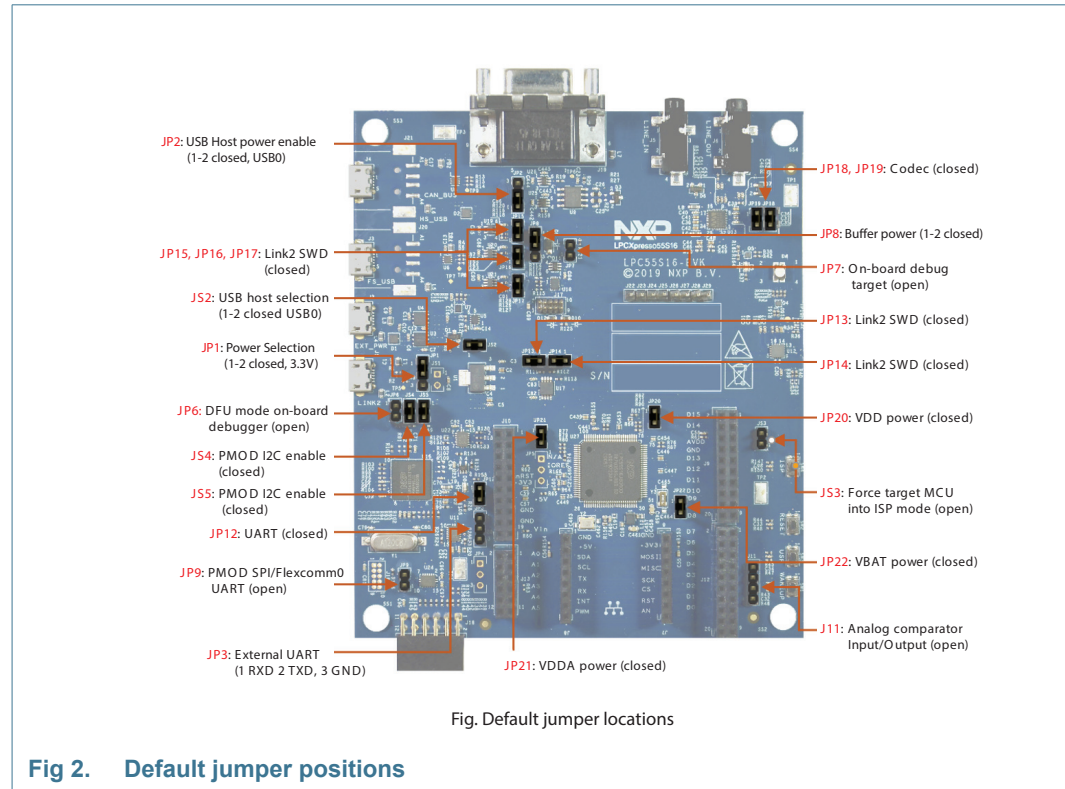

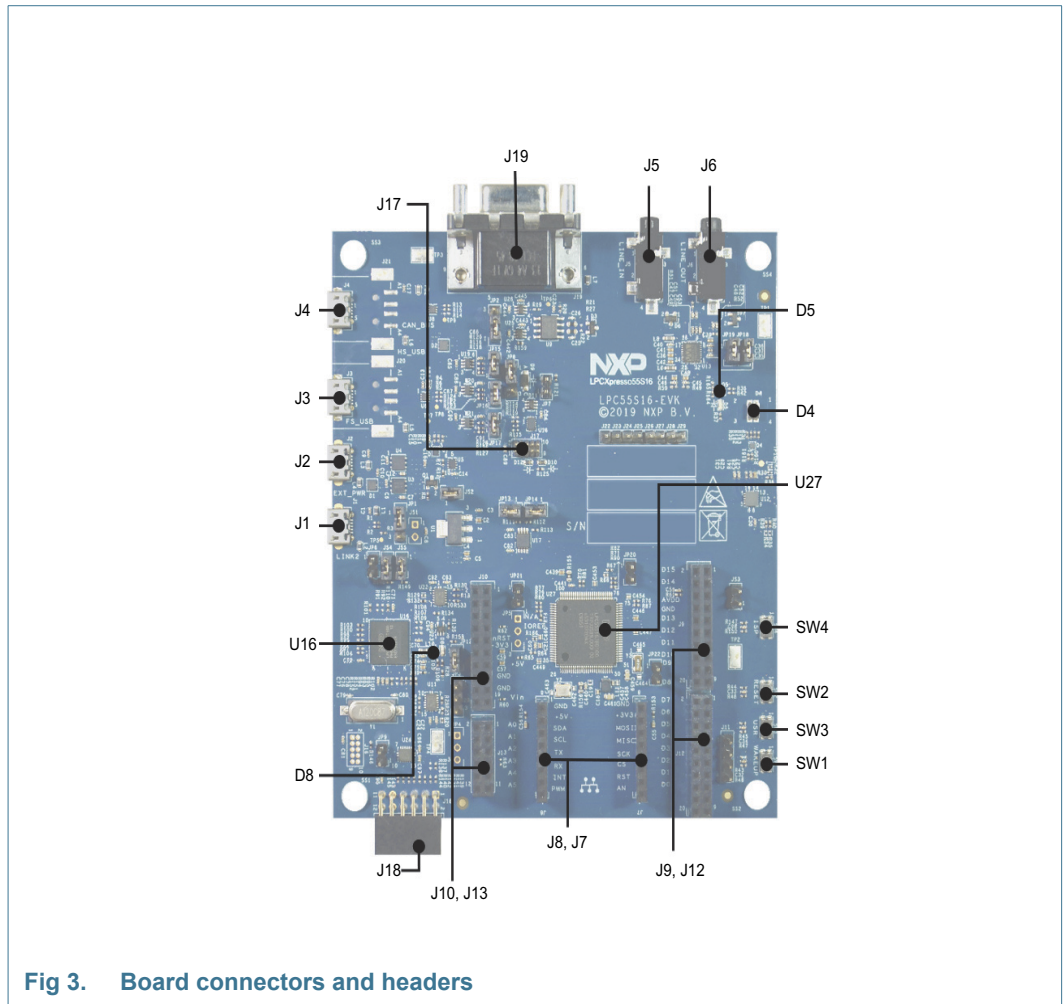

Fig 3. Board connectors and headers

Table 1. Indicators, buttons, connectors and LEDs

Circuit reference	Description	Default	Reference
D5	Target power indicator LED	n/a	n/a
D8	Link2 boot LED	n/a	Section 4.1
D4	RGB User LED (Tri-color Red/Green/Blue)	n/a	Section 7.5
J5	Audio codec line input jack.	n/a	Section 7.5
J6	Audio codec line output jack.	n/a	Section 7.5
JP8	Buffer Power Selection For On-board Target place in position 1-2 (default) For Off-board Target place in position 2-3	1-2	Section 3.1 , Section 4.4

Table 1. Indicators, buttons, connectors and LEDs

Circuit reference	Description	Default	Reference
JP6	<p>Link2 (LPC43xx) force DFU boot.</p> <p>Leave this jumper open (default) for Link2 to follow the normal boot sequence. The Link2 will boot from internal flash if image is found there. With the internal flash erased the Link2 normal boot sequence will fall through to DFU boot.</p> <p>Install this jumper to force the Link2 to DFU boot mode. Use this setting to reprogram the Link2 internal flash with a new image (using the LPCScript utility) or to use the MCUXpresso IDE with CMSIS-DAP protocol.</p> <p>Note that the Link2 flash is pre-programmed with a version of CMSIS-DAP firmware by default.</p>	Open	Section 3. , Section 4.
JP7	<p>Target processor selection for the on-board Debug Probe.</p> <p>Jumper open (default) the LPC55Sxx Target SWD interface enabled. Normal operating mode where the Target SWD is connected to either the on-board Link2 Debug Probe or an external Debug Probe.</p> <p>Jumper shunted, the LPC55Sxx Target SWD interface is disabled. Use this setting only when the on-board Link2 Debug Probe is used to debug an off-board target MCU.</p>	Open	Section 4.
JP2	<p>USB host Vbus selection</p> <p>Note that only one of USB0 or USB1 can be configured as a USB host port at any given time (this is a board restriction, not a limitation of the LPC55Sxx.)</p> <p>Install jumper in position 1-2 for USB0 (Full Speed) to provide Vbus (i.e. enable USB host capability) (Default)</p> <p>Install jumper in position 2-3 for USB1 (High Speed) to provide Vbus (i.e. enable USB host capability)</p>	1-2 (USB0)	Section 6.1
JS2	<p>USB host power control selection</p> <p>This jumper selects routing of USB port power and overcurrent detect from either the USB0 or USB1 ports of the LPC55Sxx. Note that only one of USB0 or USB1 can be configured as a USB host port at any given time (this is a board restriction, not a limitation of the LPC55Sxx.)</p> <p>Leave open when using USB1 (High Speed) as a USB host (Default)</p> <p>Install jumper for USB0 (Full Speed) to provide Vbus (i.e. enable USB host capability).</p>	Installed (USB1)	Section 6.1
JP9	<p>When open (default), the "Bridge" UART and SPI connections from the Link2 probe are driven to the LPC55Sxx target. Install JP9 when using the SPI interface at connector J18 and/or FC0 UART at JP3. Note that this disables the Link2 SPI and UART (bridge) connections.</p>	Open	Section 4.
JP1	<p>Target VDD power selection. An external supply voltage to the LPC55Sxx can also be applied through pin 2 of this header.</p>	1-2 (3.3V) 2-3 (1.8V)	Section 5.
J2	<p>External +5V power</p> <p>Micro USB connection for power to the LPC55Sxx target and peripheral circuitry (excluding Link2 Debug Probe). Must be installed for the USB host to work.</p>	n/a	Section 5. Section 6.1

Table 1. Indicators, buttons, connectors and LEDs

Circuit reference	Description	Default	Reference
J1	Link2 Debug Probe connector Micro USB type B connection for the on-board Link2 Debug Probe. Note: do not use this connection when using an external Debug Probe.	n/a	Section 4.
J17	10 pin external debug probe / off board target connector This standard Cortex-M debug connector is used either to (1) connect and off-board debug probe or (2) to connect an external debug target.	n/a	Section 3.1.3
JP3	Serial port header 0.1" header providing convenient access to Flexcom 0 USART (the USART used for ISP boot). When using this port install jumper JP9 to disable the Link2 connection to this port.	n/a	Section 3.1.3
J4	LPC55Sxx USB1 (high speed) micro AB port connector	n/a	LPC55Sxx USB Ports
J3	LPC55Sxx USB0 (full speed) micro AB port connector	n/a	LPC55Sxx USB Ports
JP20	Power to MCU VDD, once removed, it can be used to measure VDD current.	Installed	Measuring LPC55Sxx device supply current
JP21	Power to MCU VDDA, once removed, it can be used to measure VDDA current.	Installed	Measuring LPC55Sxx device supply current
JP22	Power to MCU VBAT, once removed, it can be used to measure VBAT current.	Installed	Measuring LPC55Sxx device supply current
JP5	ADC reference connector This header provides an access point to inject positive and negative voltage references for the LPC55Sxx ADC.	Open	
J9,J10,J12,J13	LPCXpresso expansion connectors, including Arduino R3 compatible site. Provides connectivity to SPI (high-speed SPI), USART (Flexcom 1), I2C (Flexcom 3 and Flexcom 1), I2S (Flexcom 7), ADC0, GPIO and PLU pins.	n/a	Section 8.
J18	PMod expansion connector / Host interface connector This connector provides access to the SPI (Flexcom 3) and I2C (Flexcom 1) ports that support LPC55Sxx ISP mode, along with 2 GPIO lines. When using the SPI port at this connector ensure jumper JP9 is installed to disable the connection to the Link2 debug probe.	n/a	Expansion connectors
J19	CAN-FD controller DB9 Male connector to CAN-FD network.	n/a	Section 7.3
J7, J8	Mikroe Click site Provides connectivity to standard Mikroe Click connectors. Shares SPI, ADC, I2C and USART connections with the J9, J10, J12, J13 expansion connectors.	n/a	Section 8.
J22 - J29	Miscellaneous GPIO pins for debugging purposes.	n/a	

Table 1. Indicators, buttons, connectors and LEDs

Circuit reference	Description	Default	Reference
SW4	ISP/User button When pressed, this button connect sport pin P0_5 to ground. Hold this button down while pressing and releasing Reset (SW2) to force the LPC55Sxx into ISP mode. Port P0_5 may also be reconfigured as a GPIO in user application code to enable this button to be used for other, user-defined purposes.	n/a	Section 7.6.1
SW1	Wake/User button This button, when pressed, pulls P1_18 to ground. A 330K ohm pull up to VDD is connected to P1_18.	n/a	Section 7.6.2
SW3	User button This button, when pressed, pulls P1_9 to ground. A 100K ohm pull up to VDD is connected to P1_9, and this port is also connected to pin 2 of expansion connector J12.	n/a	Section 7.6.2
SW2	Reset button When pressed, reset is applied to the LPC55Sxx, expansion connector (Arduino reset) J10, the Mikroe Click site reset, and U18 (debug connector J17 reset when debugging an off-board target).	n/a	Section 7.6.3

3. Getting started

This section describes how to first power up the board and then how to start a first debug session using the MCUXpresso SDK. The board is pre-programmed with a simple program indicating that the target MCU is running. Connect a micro USB cable from connector J2 to a host computer or power supply to power-up the board and run this program.

The following debug probes can be used with those development and the board (check compatibility between debug probe and IDE used, including support for Arm Cortex M33 cores):

- On-board debug probe (LPC4322 “Link2”) from connector J1
- LPC-Link2 (OM13054) debug probe from NXP or Embedded Artists
- P&E Micro probes
- Keil ULINK2 probes
- IAR I-Jet probes

Other debug probes may also be supported by IAR and Keil tools and by other IDEs/debug tools; refer the websites of these companies for further information.

3.1 Starting a debug session using the on-board (Link2) Debug Probe

By default, the Board is configured to use the on-board Debug Probe (Link2) to debug the on-board target (LPC55Sxx), using the CMSIS-DAP debug protocol pre-programmed into the Link2 Flash memory. The MCUXpresso IDE or other development tools that support the CMSIS-DAP protocol can be used in the default configuration. Check with your toolchain vendor for availability of specific device support packs for the LPC55Sxx series devices.

Note that when using the MCUXpresso IDE, the on-board Link2 can also be booted in DFU mode by installing a jumper on JP6; if this is done then the IDE will download CMSIS-DAP to the probe as needed. Using DFU boot mode will ensure that the most up-to-date / compatible firmware image is used with the MCUXpresso IDE.

Note: if the Debug Probe is set up to boot in DFU mode, the USB bridge functions (virtual COM port) and Debug Probe features will not be available if the board is not first initialized by the MCUXpresso IDE.

3.1.1 Installation steps for use with MCUXpresso IDE

Download and install the MCUXpresso IDE.

Configure and download an SDK package (with the MCUXpresso IDE tool chain option selected) from the MCUXpresso SDK Builder utility (<http://mcuxpresso.nxp.com>).

Ensure jumper JP8 is fitted in position 1 - 2 (local target powered), and JP7 is not installed (target SWD enabled). These are the default positions set during board manufacture.

Connect the board to the USB port of your host computer, connecting a micro USB cable to connector J1. The board will boot and run the pre-installed demo.

The board is now ready to be used with the MCUXpresso SDK examples for the LPCXpresso55S16.

When the board is used for the first time, it is recommended to force the LPC55Sxx target into a known state by performing an ISP boot before attempting to run your first example code. This can be achieved by pressing and holding down the ISP button while pressing and releasing the reset button or installing the LPC55Sxx ISP jumper.

3.1.2 Installation steps to use Keil and IAR tools with on-board debug probe

Download and install LPCScript (<https://www.nxp.com/lpcscript>). This will install required drivers for the board. Note that the Link2 (LPC4322 device) is pre-programmed with CMSIS-DAP firmware. If you have previously installed LPCScript please ensure version 2.1 or later is installed.

Ensure jumper JP8 is fitted in position 1-2 (local target powered), and J7 is not installed (target SWD enabled). These are the default positions set during board manufacture.

The Link2 Debug Probe on the board will have been programmed with CMSIS-DSP firmware during manufacture, but can also be updated with J-link OB for LPC-Link2. To start the board with this firmware running, ensure JP6 is not installed as power is connected, so the Link2 Debug Probe boots from internal flash. If you wish to update/change the Link2 firmware please follow the steps described in [Section 4.2](#).

Connect the Board to the USB port of your host computer, connecting a micro USB cable to connector J1 ("Debug-Link"). The board will boot and run the pre-installed demo. Allow about 30 seconds for the Link2 devices to enumerate for the first time. It is not necessary to check the Hardware Manager on your host computer, however if this is done there will be five devices (if using CMSIS-DAP protocol); four under Human Interface Devices (CMSIS-DAP, LPC-SIO, two HID Compliant Devices, and a USB Input Device) and one under Ports (LPC-LinkII Ucom).

Your board is now ready to use with your 3rd party tool. Follow the instructions for those tools for using a CMSIS-DAP probe. MCUXpresso IDE can also be used with the board after setting up the board this way.

When the board is used for the first time, it is recommended to force the target into known state by performing an ISP boot before attempting to run your first example code. This can be achieved by pressing and holding down the ISP button while pressing and releasing the reset button.

3.1.3 Starting a debug session using an external Debug Probe

Code running on the LPC55Sxx target can be debugged using an external Debug Probe that conforms to the standard ARM Cortex-M debug connector. To use an external Debug Probe connect the probe to the SWD connector (J17) and connect power via the micro USB connector J2.

Note: The Debug link USB connector J1 must be left unconnected so that the Link2 Debug Probe is left unpowered and does not contend with the SWD interface signals from the external Debug Probe. Also note that the VCOM function provided by the on-board Debug Probe is not available when using an external debug probe. Then, J3 serial port header can be served as an alternative to provide convenient access to Flexcomm 0 USART. When using this port, ensure jumper JP9 is installed and JP12 is open.

4. On-board (Link2) Debug probe

This section describes the features provided by the on-board Link2 Debug Probe, including how to use this to debug an external target.

The Link2 Debug Probe is implemented using an LPC432x MCU (circuit reference U16), which provides a high speed USB port interface to the host computer that runs the development tools. This device is not intended for developer use, and should only be used with approved firmware images from NXP. The Link2 on-chip flash memory is factory programmed with a firmware image that supports CMSIS-DAP debug protocol, but also includes other USB end point functions:

- Virtual COM (VCOM) port: a serial device that can be used with any host computer application design for serial port communication (e.g. Teraterm, puTTY, etc.) Set the terminal program for baud rate to 115200, no parity, 8 bit data, 1 stop bit, no flow control.
- SWO trace end point: this virtual device is used by MCUXpresso to retrieve SWO trace data. See the MCUXpresso IDE documentation for more information.
- I2S/SPI bridges: bridge device from I2C and SPI ports of the LPC target.

All of these devices are independent of each other and of the CMSIS-DAP debug device that is enumerated when the board is connected to a host computer; for example, the VCOM port can be used if the board is running an application when no debugger is running.

In order to correctly install and use the Link2 device on the LPCXpresso55S16 (required for any debugging purpose) for Windows host computers, install the drivers first. These drivers will automatically be installed when MCUXpresso IDE has already been installed. If these IDEs are not being used, it is recommended LPCScript be installed as this also includes the required drivers. All these tools and utilities are available for free download at <https://www.nxp.com/lpcscript>.

The CMSIS-DAP firmware image installed at the factory (and by LPCScript) will uniquely identify itself to the host computer so that more than one board can be connected to that host computer at any time. Some toolchains cannot discern between multiple debug devices; refer to your toolchain documentation for more information (note the MCUXpresso IDE does support multiple LPCXpresso board targets.)

Note: The Link2 only boots when the board is power cycled; the reset button on the board does not reset the Link2.

When using MCUXpresso IDE, the Link2 can be automatically booted with the latest / most appropriate firmware for that IDE version by installing JP6 (DFU jumper) before powering up the board. This is the recommended approach for the MCUXpresso IDE. Note that if JP6 is installed when powering the board then the VCOM port (and other devices mentioned above) device will not appear until the MCUXpresso IDE boots the Debug Probe. The Debug Probe is booted once a debug session is started (that is, the IDE attempts to download code to the target).

4.1 Link2 boot LED

LED D8 is the Link2 MCU BOOT0_LED indicator. This LED reflects the state of Link2 MCU pin P1_1. When the boot process fails, D8 will toggle at a 1 Hz rate for 60 seconds. After 60 seconds, the Link2 MCU is reset.

4.2 Programming the Link2 firmware

As mentioned earlier in this section, it is not normally necessary to program the Link2 firmware. However, this can easily be accomplished using the supporting utility, LPCScript.

To program the Link2 Flash the Link2 device (LPC432x) must be in DFU mode. If the Link2 already has a valid image in the flash, it will need to be forced into DFU mode by placing a jumper shunt on JP6 (DFU), and power cycling (disconnecting then reconnecting power via J1.) Link2 MCU programming is performed using the LPCScript utility (see <http://www.nxp.com/lpcscript>). Instructions for using the tool are located at the same web page.

After installing LPCScript, use either the "Program LPC-Link2 with CMSIS-DAP" or "Program LPC-Link2 with JLink" utilities provided in that installation to update the firmware, following on-screen instructions.

4.3 VCOM port

The identifier of the VCOM port will vary between boards and hosts as each board will enumerate with a unique identifier. On Windows, to determine the COM port, open the Windows operating system Device Manager. This can be achieved by going to the Windows operating system Start menu and typing "Device Manager" in the search bar. In the device manager look under "Ports"; the LPC-LinkII UCom Port device and its name should be visible. NOTE: this VCOM port will only appear if (a) the Debug Probe has been programmed with the CMSIS-DAP firmware and the Debug Probe DFU link (JP6) is removed at power up, or (b) if the Debug Probe has been configured for DFU boot (JP6 installed) at power up and MCUXpresso IDE has booted it (by starting a debug session).

If the J-Link firmware image has been programmed into the Debug Probe and DFU boot mode is not being used, then a VCOM device called J-Link CDC UART port will appear instead of the LPC-LinkII UCom port.

Note that the VCOM port is not available when the Link2 Debug Probe is not powered. When using an external debug probe. Then, J3 serial port header can be served as an alternative to provide convenient access to Flexcomm 0 USART. When using this port, ensure jumper JP9 is installed and JP12 is open.

4.4 Configuring the LPCXpresso55S16 to debug an off-board target

The LPCXpresso55S16 board's Link2 Debug Probe may be used to debug an off-board target MCU. The on-board Link2 Debug Probe is capable of debugging target MCU's with a VDDIO range of 1.6V to 3.6V. To keep the on-board target LPC55Sxx MCU from interfering with the SWD interface, JP7 must be closed. The Link2 Debug Probe SWD should be connected by a ribbon cable between the J17 connector to the off-board target MCU SWD interface. Power the LPCXpresso55S16 board from the Link USB connector J1, and fit jumper JP8 across pins 2 - 3 (External Target).

5. Board Power

The LPCXpresso55S16 board requires +5V input to power the on-board voltage low dropout linear regulators, of which there are 3, circuit reference U1, U3 and U4.

The Link2 Debug probe has a 2.5V regulator (U1) which draws power from USB connector J1 ("Debug Link") only.

There are two other regulators, providing the option of 1.8V (U4) or 3.3V (U3) to the other devices on the board; these regulators can be powered by any of the following (+5V) sources:

- USB Debug Link connector (J1)
- USB +5V Power only connector (J2)
- USB Full Speed connector for LPC55Sxx (J3)
- USB High Speed connector for LPC55Sxx (J4)

The +5V sources above are connected via protection diodes to prevent reverse powering of any of them by another source. The +5V output of these combined sources is also connected to the Arduino and Mikroe expansion sites. Note that if J3 or J4 is configured as a USB host port then those connectors will not supply power to the board and another power source must be provided through J2.

Note that the FXOS8700 Accelerometer requires the board to be configured for 3.3V operation.

CAN-FD transceiver, circuit reference U9, TJA1044, is populated to support CAN-FD communication. CAN-FD transceiver requires +5V supply.

For further details, refer to the board schematics.

5.1 Measuring LPC55Sxx device supply current

Current supply to the LPC55Sxx Core can be measured via JP20 for VDD, JP21 for VDDA, and JP22 for VBAT.

5.2 1.8V operation

Please note the minimum voltage supply for the LPC55S1x/LPC551X devices is 1.8 V, so variations in the 1.8V regulator tolerance and/or loading on the regulator may cause the brown-out detect (BOD) to trigger, especially when using the device at higher operating frequencies (when current draw is higher). The default BOD settings may be changed to avoid this problem, before higher clock speeds and/or higher current draw I/Os are enabled (e.g. at the start of main()) with a function call to the power library, as shown below:

```
POWER_SetBodVbatLevel(kPOWER_BodVbatLevel1650mv, kPOWER_BodHystLevel50mv, false);
```

It should be noted that this workaround may not work in all cases due to the regulator used on the board has a tolerance that does not guarantee the minimum required voltage output; see: [Section 10 "Errata"](#).

6. Board serial connections

This section describes connections between LPC55Sxx on-board serial peripherals and connectors for use with off-board devices.

6.1 LPC55Sxx USB Ports

The Board incorporates micro AB connectors for both of USB0 (Full Speed, connector J3) and USB1 (High Speed, connector J4) ports of the LPC55S16. Both of these ports are capable of operating as a device or a host, and this is why micro AB connectors are used.

The Board can only be configured to support one of these ports as a host at a time (this is a limitation of the board, not the LPC55Sxx). When either port is used as a host, power must be supplied to the board via the +5V power only micro B USB port. Jumper JP2 is used to connect power from a load switch to the VBUS signal of the port selected; JP2 should be placed in position 1-2 for USB0 or position 2-3 for USB1. If neither USB port is being used as a USB host this jumper is not required.

6.2 USART header

Header JP3 is provided as a convenient way to use an LPC55Sxx USART with a serial to USB cable. Flexcom 0 ports (P0_29 and P0_30) are used for this feature, since these ports are assigned for USART ISP mode. Note that these ports are shared with the Link2 debug probe (LPC4322) and PMod connector; when using this header ensure that there is no conflicting device connected to the PMod connector and that jumper JP9 is installed to disable the connection to the Link2 and JP12 jumper should be open. Always ensure the serial cable is only connected when the board is powered to prevent the LPC55S16 being powered through this TXD/RXD pins.

Note: the silkscreen on the board is labeled from the perspective of a serial cable connected to the board, so JP3 pin 3 (labeled “RXD” on the board silkscreen) is connected to PIO0_30 (Flexcomm0 TXD), and JP3 pin 2 (labeled “TXD” on the board silkscreen) is connected to PIO0_29 (Flexcomm0 RXD).

7. On-board peripherals

This section describes how the on-board peripheral devices of the Board are connected to the LPC55Sxx and relevant configuration options. For full details of these devices please refer to the individual device datasheets. For circuit further details, refer to the board schematics.

7.1 Audio Codec

The LPCXpresso55S16 board incorporates a Cirrus Logic (Wolfson) WM8904 audio codec. This codec has both I2C (for control) and I2S (for data) interfaces.

The I2C interface of the codec is routed to Flexcomm 4 of the LPC55Sxx, the same connection as used for the other I2C devices on the board; the Codec has an address of 0b0011010x.

The Flexcomm 6 and Flexcomm 7 interfaces of the LPC55Sxx are connected respectively to the Codec for data sent to / receive from the Codec. The board design assumes pad sharing between Flexcom 6 and Flexcom 7 for I2S connections.

Table 2. Audio Codec port connections

Circuit reference	Port	Flexcoms
I2S SCK	P0_21	Flexcom 6 & 7, pad shared
I2S TX Data	P0_20	Flexcom 7
I2S RX Data	P1_13	Flexcom 6
I2S WS	P0_19	Flexcom 6 & 7, pad shared
I2C SDA	P1_21	Flexcom 4
I2C SCL	P1_20	Flexcom 4
I2S_MCLK	P1_31	

I2S connections from the LPC55Sxx are also connected to the Expansion connectors; solder jumpers may be removed to disconnect the on-board codec if an external I2S device is to be used instead.

Line input (J5) and line output (J6) 1/4" stereo jack sockets provide analog I/O connections to the Codec. See schematic for further information.

7.2 CAN-FD Connector

The LPC55S16 MCU includes a CAN-FD controller. On LPCXpresso55S16 board, P1.22 (IOCON Function 9) and P1.27 (IOCON Function 9) are configured as CAN_RXD and CAN_TXD respectively. A CAN-FD transceiver, U9, TJA1044, is populated on the board with level shifters between LPC55S16 target and CAN-FD transceiver to support both 1.8V and 3.3V. LPCXpresso55S16 board incorporates a DB9 connector (J19) to support CAN-FD communication.

CAN-FD software driver examples are provided as part of the MCUXpresso SDK.

7.3 Accelerometer

The board includes an NXP FXOS8700 accelerometer, interfaced to Flexcom 4 (ports P1_21 and P1_20) with its interrupt output connected to P1_26 (this signal is also shared with the Expansion connector J12 via a 100 ohm resistor (R36).) The accelerometer has an I2C address of 0b0001111X.

I2C software drivers are provided as part of the MCUXpresso SDK, and example code is provided to illustrate how to read values from the accelerometer.

7.4 Crystals

For applications requiring high-speed communication such as high-speed USB and accurate clock such as real-time clock (RTC), two external crystal oscillators are provided on the board, 16MHz crystal for XTAL32M and 32.768KHz for XTAL32K.

External capacitors are not required on the crystal pins, but are installed on board. These may be removed for better performance if issues are observed. See the "LPC55S1x/LPC551x Cap Bank API" chapter of the LPC55S1x/LPC551x User manual for further information.

7.5 RGB User LED

An User controlled RGB LED is provided on the Board. The LEDs in this device are

controlled by LPC55Sxx ports P1_4 (Red), P1_6 (Blue), P1_7 (Green) with the LEDs being illuminated when the respective GPIO pin is set to high. Note that these port lines are also connected to expansion connector J12.

7.6 Buttons

Four buttons are provided on the LPCXpresso55S16 board, as described in this section.

7.6.1 ISP (SW4)

P0_5 is pulled up to VDD via a 100kohm resistor; pressing this button will pull P0_5 low. This port is read by the LPC55Sxx boot code to determine if the MCU should enter In System Programming (ISP) mode. The main purpose of this button is to force the LPC55Sxx into ISP mode at boot time; to do this hold down this button while pressing and releasing the Reset button, or while connecting power to the board. While the main purpose of ISP mode is to program the flash of the LPC55Sxx, forcing the MCU into this mode places it into a known state in which development tools can gain debug control. If an application in flash is crashing or disabling the SWD port unintentionally, then ISP mode can be useful to recover control of the board. Refer to the LPC55S1x User Manual for more information on ISP mode.

The ISP button can also be used in user application code. Care should be taken if P0_5 is configured as an output driving high, since pressing this button will short it to ground.

Note that jumper JS3 may also be used as a convenient way to always assert ISP when the LPC55Sxx is reset or powered up.

7.6.2 User (SW3) and Wakeup (SW1) buttons

The User (SW3) and Wakeup (SW1) buttons are intended for user application use. These buttons pull ports P1_9 (User) with 100kohm pull-up resistor and P1_18 (Wakeup) with 330kohm pull-up resistor low when the button is pressed.

7.6.3 Reset (SW2)

Pressing this button will assert reset to the LPC55Sxx and to the Mikroe and Arduino connector sites. Note that the Link2 Debug Probe (LPC4322) is not reset when this button is pressed.

8. Expansion connectors

The LPCXpresso55S16 includes 3 expansion connector sets, incorporating support for Arduino UNO R3, Mikroe Click and PMod standards. The Arduino UNO connector footprint is surrounded by additional connectors that are compatible with other LPCXpresso V3 boards. For further details, refer to the board schematics.

8.1 Mikroe Click Site

The connectors J7 and J8 provide a Mikroe Click module site for the wide range of add-on modules available from MikroElektronika. Note that this site shares the same SPI, I2C and UART connections as the Arduino/LPCXpresso V3 expansion connectors.

8.2 Host / PMod Connector

Connector J18 is a connector which provide convenient access for a remote host to the SPI and I2C ports of the LPC55Sxx that support ISP mode. When setting up the Board to be used with a host, jumper JP9 must be installed to prevent conflict with the Link2 (which can also emulate an SPI or I2C host).

8.3 Arduino and LPCXpresso V3 expansion connectors

The connectors J9, J10, J12, J13, provide Arduino UNO R3 compatibility and access to several other signals for use in prototyping. The overall footprint is compatible with the LPCXpresso V3 expansion connector footprint used on other LPCXpresso boards of this type. Note that some ports used on these connectors are shared with other devices/connectors on the board, including the Mikroe Click site, audio codec and RGB LED. Refer to the schematic for further information.

When using an Arduino shield with the Board, align the Arduino shield (SCL) with pin 1 of connector J9 on the LPCXpresso55S16 board.

Table 3. Arduino and LPCXpresso V3 expansion connections

Expansion connector	Port
J9	The odd number pins are compatible with Arduino Uno rev3 Digital 15:8, AREF, SDA & SCL connector. The even numbered pins are used for external access and expansion of LPC55Sxx signals not used by the Arduino Uno rev3 compatible interface.
J12	The odd numbered pins 1 – 15 are compatible with Arduino Uno rev3 Digital 7:0 connector. The even numbered pins, and odd numbered pins 17 and 19, are used for external access and expansion of LPC55Sxx signals not used by the Arduino Uno rev3 compatible interface.
J10	The even numbered pins 6 – 20 are compatible with the Arduino Uno rev3 Power connector standard.
P13	The even numbered pins 2 – 12 are compatible with Arduino Uno rev3 Analog connector. The odd numbered pins are used for external access and expansion of LPC55Sxx signals not used by the Arduino Uno rev3 compatible interface.

9. Board Power

This section describes miscellaneous board features that we not covered elsewhere in this manual.

9.1 LPC55Sxx ADC references and inputs

By default, the LPC55Sxx ADC positive reference is connected to VDDA and the negative reference to ground. Different reference voltages may be used by removing R65 zero resistor and connecting an external reference to JP5 (pin 1 for positive, pin 3 for negative).

An external differential ADC input signal can be applied at J13 or at the JP4 expansion connector. This connection is routed to PIO0_16 and PIO0_23.

10. Errata

This section provides errata for commonly known issues that may occur during device processing.

10.1 Brown-out detect (BOD) may be triggered during boot (code execution from ROM)

Boards have a 1.8V regulator installed that has a 2% tolerance. This can result in the supply voltage being below the specification of the LPC55S1x/LPC551x device and thus in some cases the brown-out detect (BOD) of the device may trigger during boot (code execution from ROM). If this occurs it will prevent an application programmed in SRAM or flash from executing. In this situation, an external 1.8V supply may be connected to the center pin of P4 to power the LPC55S1x/LPC551x device. Note that board designs should use a regulator that guarantees a minimum 1.8V supply; alternative regulators with 1.9V or 2V outputs are available from Torex in their XC6203 family in the same footprint, and also in the XC6503 range, and other alternatives are available from other suppliers.

Some boards have passive components installed that are not necessary and should be omitted in application designs; see: [Section 6.1 “LPC55Sxx USB Ports”](#) and [Section 7.4 “Crystals”](#).

10.2 Proper termination resistors required between the MCU and the USB connector

USB0 port uses the FS/LS driver which needs to have 33 Ohm external series termination resistors between the MCU and the USB connector. Without proper termination, a failure in the USB signal quality during USB compliance testing may occur. Zero Ohm resistors on R6 and R8 should be replaced with 33 Ohm resistors.

11. Board operating conditions

These boards have been designed for use in laboratory conditions (0 to 50 degrees Celsius) and should not be used for extended temperature testing. Refer to the data sheet of the LPC55xx MCU being used for full operating conditions for that device.

12. Legal information

12.1 Definitions

Draft — The document is a draft version only. The content is still under internal review and subject to formal approval, which may result in modifications or additions. NXP Semiconductors does not give any representations or warranties as to the accuracy or completeness of information included herein and shall have no liability for the consequences of use of such information.

12.2 Disclaimers

Limited warranty and liability — Information in this document is believed to be accurate and reliable. However, NXP Semiconductors does not give any representations or warranties, expressed or implied, as to the accuracy or completeness of such information and shall have no liability for the consequences of use of such information.

In no event shall NXP Semiconductors be liable for any indirect, incidental, punitive, special or consequential damages (including - without limitation - lost profits, lost savings, business interruption, costs related to the removal or replacement of any products or rework charges) whether or not such damages are based on tort (including negligence), warranty, breach of contract or any other legal theory.

Notwithstanding any damages that customer might incur for any reason whatsoever, NXP Semiconductors' aggregate and cumulative liability towards customer for the products described herein shall be limited in accordance with the *Terms and conditions of commercial sale* of NXP Semiconductors.

Right to make changes — NXP Semiconductors reserves the right to make changes to information published in this document, including without limitation specifications and product descriptions, at any time and without notice. This document supersedes and replaces all information supplied prior to the publication hereof.

Suitability for use — NXP Semiconductors products are not designed, authorized or warranted to be suitable for use in life support, life-critical or safety-critical systems or equipment, nor in applications where failure or

malfunction of an NXP Semiconductors product can reasonably be expected to result in personal injury, death or severe property or environmental damage. NXP Semiconductors accepts no liability for inclusion and/or use of NXP Semiconductors products in such equipment or applications and therefore such inclusion and/or use is at the customer's own risk.

Applications — Applications that are described herein for any of these products are for illustrative purposes only. NXP Semiconductors makes no representation or warranty that such applications will be suitable for the specified use without further testing or modification.

Customers are responsible for the design and operation of their applications and products using NXP Semiconductors products, and NXP Semiconductors accepts no liability for any assistance with applications or customer product design. It is customer's sole responsibility to determine whether the NXP Semiconductors product is suitable and fit for the customer's applications and products planned, as well as for the planned application and use of customer's third party customer(s). Customers should provide appropriate design and operating safeguards to minimize the risks associated with their applications and products.

NXP Semiconductors does not accept any liability related to any default, damage, costs or problem which is based on any weakness or default in the customer's applications or products, or the application or use by customer's third party customer(s). Customer is responsible for doing all necessary testing for the customer's applications and products using NXP Semiconductors products in order to avoid a default of the applications and the products or of the application or use by customer's third party customer(s). NXP does not accept any liability in this respect.

Export control — This document as well as the item(s) described herein may be subject to export control regulations. Export might require a prior authorization from national authorities.

12.3 Trademarks

Notice: All referenced brands, product names, service names and trademarks are the property of their respective owners.

13. Contents

1	Introduction	3	12	Legal information	19
2	Board layout and Settings	4	12.1	Definitions	19
3	Getting started	8	12.2	Disclaimers	19
3.1	Starting a debug session using the on-board (Link2) Debug Probe.	8	12.3	Trademarks	19
3.1.1	Installation steps for use with MCUXpresso IDE	9	13	Contents	20
3.1.2	Installation steps to use Keil and IAR tools with on-board debug probe	9			
3.1.3	Starting a debug session using an external Debug Probe	10			
4	On-board (Link2) Debug probe	11			
4.1	Link2 boot LED	12			
4.2	Programming the Link2 firmware	12			
4.3	VCOM port	12			
4.4	Configuring the LPCXpresso55S16 to debug an off-board target	12			
5	Board Power	13			
5.1	Measuring LPC55Sxx device supply current .	13			
5.2	1.8V operation	13			
6	Board serial connections	14			
6.1	LPC55Sxx USB Ports	14			
6.2	USART header	14			
7	On-board peripherals	14			
7.1 Audio Codec	14			
7.2	CAN-FD Connector	15			
7.3	Accelerometer	15			
7.4	Crystals	15			
7.5	RGB User LED	15			
7.6	Buttons	16			
7.6.1	ISP (SW4)	16			
7.6.2	User (SW3) and Wakeup (SW1) buttons	16			
7.6.3	Reset (SW2)	16			
8	Expansion connectors	16			
8.1	Mikroe Click Site	16			
8.2	Host / PMod Connector	17			
8.3	Arduino and LPCXpresso V3 expansion connectors	17			
9	Board Power	17			
9.1	LPC55Sxx ADC references and inputs.	17			
10	Errata	18			
10.1	Brown-out detect (BOD) may be triggered during boot (code execution from ROM)	18			
10.2	Proper termination resistors required between the MCU and the USB connector	18			
11	Board operating conditions	18			

Please be aware that important notices concerning this document and the product(s) described herein, have been included in section 'Legal information'.

© NXP B.V. 2020

All rights reserved.

For more information, please visit: <http://www.nxp.com>

For sales office addresses, please send an email to: salesaddresses@nxp.com

Date of release: 20 October 2020

Document identifier: UM11423