

Developer's Serial Bootloader

by: Pavel Lajsner, Pavel Krenek, Petr Gargulak

1 Project objectives

The developer's serial bootloader offers to user easiest possible way how to update existing firmware on most of Freescale microcontrollers in-circuit. In-circuit programming is not intended to replace any of debugging and developing tool but it serves only as simple option of embedded system reprogramming via serial asynchronous port or USB. The microcontrollers supported by the developer's serial boot loader include 8-bit families HC08 and HCS08, and 32-bit families, ColdFire and Kinetis. New Kinetis families include support for K and L series.

This application note is for embedded-software developers interested in alternative reprogramming tools. Because of its ability to modify MCU memory in-circuit, the serial bootloader is a utility that may be useful in developing applications.

The developer's serial bootloader is a complementary utility for either demo purposes or applications originally developed using MMDS and requiring minor

Contents

1	Project Objectives	1
2	FC Protocol Description	3
3	FC Protocol, Version 1, M68HC908 Implementation	12
4	FC Protocol, Version 2, HC9S08 Implementation	18
5	FC Protocol, Version 3, Large M68HC08 Implementation	23
5	FC protocol, version 4, ColdFire (V1)	23
6	MCU Slave Software	23
7	PC Bootloader Master Software	41
8	Bootloading Procedure Demonstration	46
9	References	51

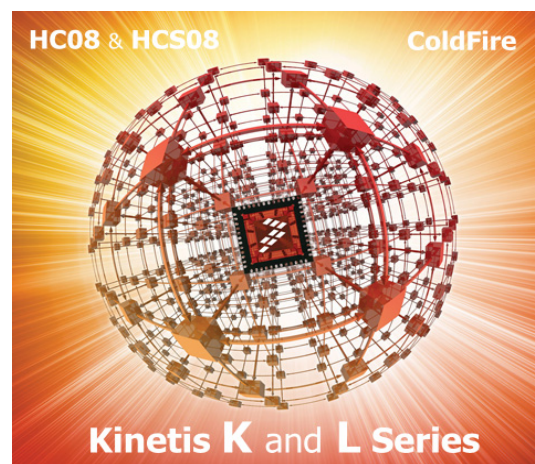

Project objectives

modifications to be done in-circuit. The serial bootloader offers a zero-cost solution to applications already equipped with a serial interface and SCI pins available on a connector. This document also describes other programming techniques:

- FLASH reprogramming using ROM routines
- Simple software SCI
- Software for USB (HC08JW, HCS08JM and MCF51JM MCUs)
- Use of the internal clock generator
- PLL clock programming
- EEPROM programming (AS/AZ HC08 families)
- CRC protection of serial protocol option

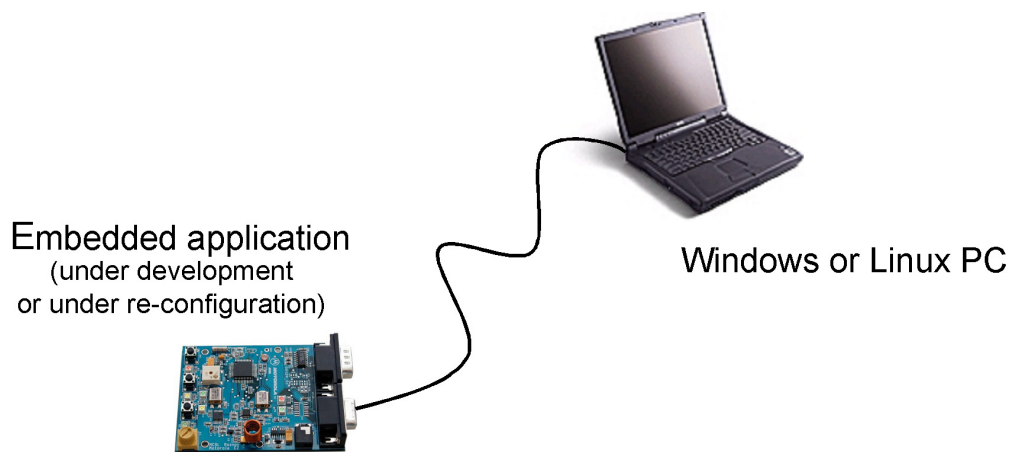

Figure 1. Top-level view

1.1 Project goals

Freescale Semiconductor M68HC08 MCUs use a standard monitor-mode interface for FLASH programming. Configuration of monitor mode requires a specific clock and high-voltage (monitor-mode entry voltage $V_{TST} = V_{DD} + 2.5 = 8 \text{ V}$) applied to the IRQ pin upon MCU startup. Also, establishing monitor-mode communication uses a few pins. If the application already uses a standard serial SCI interface for communication, a different code (the bootloader) can be used to communicate with the PC using the same interface used for reprogramming.

The bootloader can be used for only reprogramming, not for in-circuit debugging. The bootloader is a low-cost in-circuit programming solution.

1.2 Bootloader application requirements

The following points described important parameters of the bootloader application:

- **Low memory use** — The bootloader must use as little memory as possible. Other versions of bootloaders use more than 1 KB of memory, which is unacceptable on devices with 3 KB of memory available (such as the MC68HC908JK3). The solution described in this document

implements all features as simply as possible, excluding checksums, and so forth. The target size is less than 500 B for the 8-bit MCUs. The USB version of bootloaders included drivers for the communication over the USB. For this bootloaders is needed 8KB memory available (HCS08JM and MCF51JM). The Kinetis K and L series have a similar sizes (less than 2 KB).

- **Low pin-count** — This bootloader uses already implemented standard means of communication (typically SCI on boards primarily intended for communication). The standard SCI uses two wires, RxD and TxD. No additional wires are used to start bootloader.
- **Transparency with respect to the user S19 file** — The complete application should be transparent to the user code S19 file. This means no adjustments are required in the S19 file. Other M68HC08, HCS08, and ColdFire V1 bootloader applications require modification to interrupt vectors or other modifications to the S19 file for it to accept the bootloader.

1.3 Demo features of bootloader application

This document describes several different M68HC(S)08, ColdFire V1 (CFV1), and Kinetis bootloader implementations that vary mainly because the targets M68HC(S)08, CFV1, and Kinetis MCUs have different features. Several features of the M68HC(S)08, CFV1, and Kinetis Family are also demonstrated, making this document useful to a wider audience than those who require only the bootloader. The different M68HC(S)08, CFV1, and Kinetis implementations also demonstrate the following features:

- Use of built-in ROM routines for FLASH self-programming (see also AN1831, AN2545, and AN2635 in [References](#)).
- User implementation of in-circuit reprogramming routines on ROM-less MCUs such as the [MC68HC908GP](#) Family or the [MC9S08GB/GT](#) Family.
- Use of different implementations of the FLASH block protection technique ([MC68HC908GP](#), [MC68HC908GR](#), [MC68HC908EY](#), versus [MC68HC908JK/JL](#) Families).
- Implementation of software SCI on SCI-less MCUs, such as the [MC68HC908JK/JL](#) Family.
- Use of the internal clock generator and its trimming (for the [MC68HC908KX](#) Family), for HCS08 Families ([MC9S08GB/GT](#)).
- EEPROM programming (for the [MC68HC908AB/AS/AZ](#) Family).
- USB communication implementation on USB2.0 Full-speed HS08 MCUs, such as the [MC68HC908JW](#) Family, [HCS08JM](#) and [MCF51JM](#) Family.
- Use implementation of flash programming routines for the HCS08 and the ColdFire (V1) devices (see also AN3492 in [References](#)).

2 FC protocol description

As described in [Bootloader application requirements](#) implementation must be simple and use low memory. Therefore, the protocol running between the master PC and slave MCU is also very simple. It is called FC protocol because one significant character (acknowledge or ACK) 0xFC or 11111100b is used.

This section describes the protocol used to communicate between the PC and target MCU to reprogram the MCU. An explanation of family-specific implementation features follows a general description.

The following is a simplified state diagram that shows separate states of the bootloader, which is described in this document:

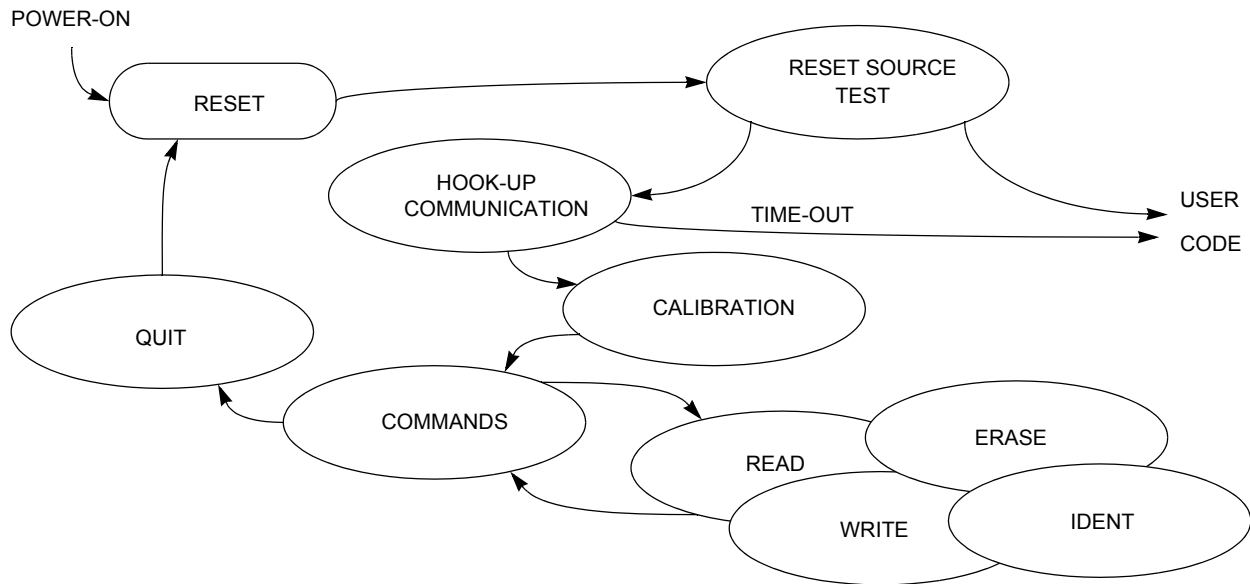

Figure 2. Simplified flow diagram of the bootloader application

2.1 Initial hook-up

Several methods can be used to enter bootloader mode. Several other solutions use a “*certain level on certain pin*” method. For example, if logic 0 appears on an IRQ pin during MCU startup, the bootloader code starts else the user code starts.

Because the developer’s serial bootloader application must use the lowest number of pins, a “*certain character at a certain time*” method is used. This means that the MCU sends out an ACK character through the serial interface and waits for an answer. If no character is received within the specified time (hook-up time-out), the process continues with the user code.

If this becomes a limitation for any reason, the user may modify the bootloader code to meet the application needs (for example, an additional simple IRQ pin test at startup can be implemented). For more details, see [M68HC08 system limitations](#).

2.2 Clock source

FC protocol allows two scenarios, depending on whether the MCU runs on a known and exact frequency or uses an RC (resistor, capacitor) clock or an internal clock (or any clock unknown at compile time).

2.2.1 Unknown MCU communication speed

If the frequency is uncertain (unknown at compile time), the MCU will not check whether an incoming ACK character conforms only to the 0xFC pattern. Because of the MCU clock tolerance, several

characters can be interpreted differently instead of original 0xFC sent out by the PC (Figure 3). The 0xFC pattern check on the MCU side can be eliminated completely, which saves MCU memory.

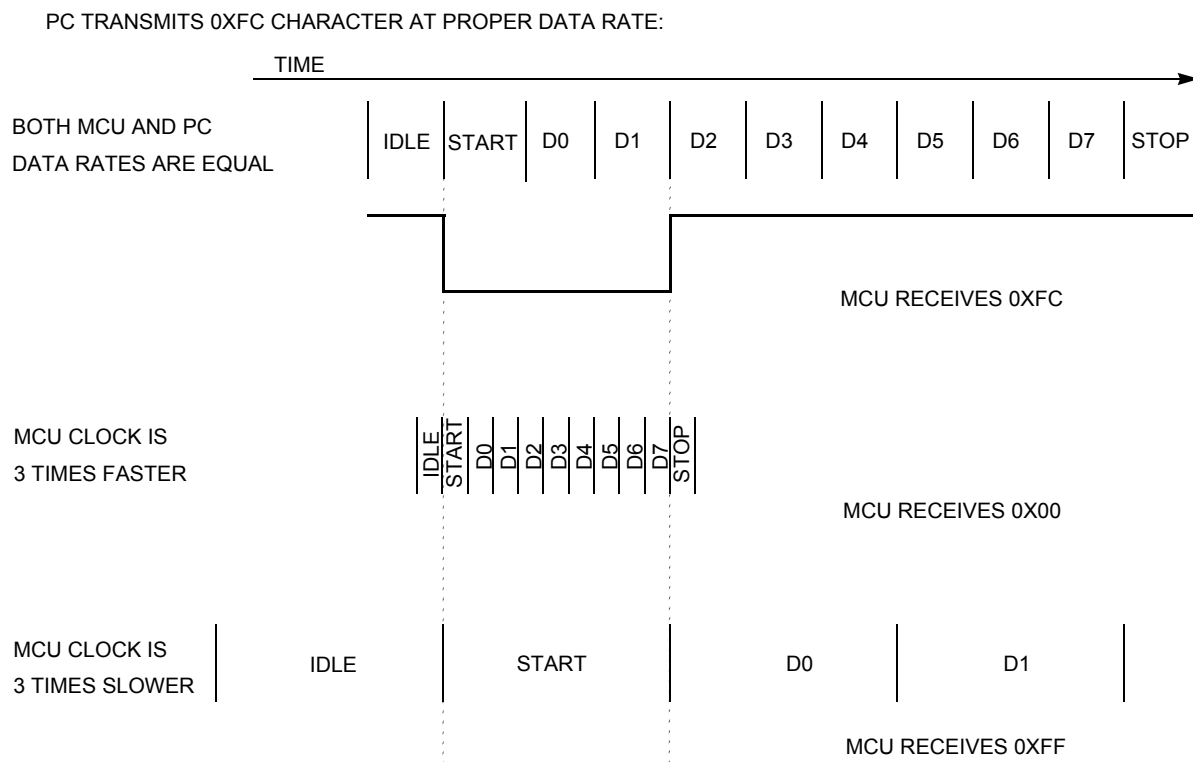

Figure 3. Matching different communication speeds

The following table shows the characters that can be correctly received (without framing or noise errors) if transmit and receive speeds are not equal:

Table 1. PC to MCU transmission — unmatched data rate

PC Data Rate	MCU Data Rate	Character Received in Binary	Character Received in Hex
9600	9600*1/3	11111111b	0xFF
9600	9600*2/3	11111110b	0xFE
9600	9600*3/3	11111100b	0xFC
9600	9600*4/3	11111000b	0xF8
9600	9600*5/3	11110000b	0xF0
9600	9600*6/3	11100000b	0xE0
9600	9600*7/3	11000000b	0xC0
9600	9600*8/3	10000000b	0x80
9600	9600*9/3	00000000b	0x00

If the MCU transmits to the PC at an unmatched data rate, the PC receives (and accepts) characters that are different from the 0xFC character. The PC accepts all characters from the mentioned set (0xFF, 0xFE, 0xFC, 0xF8, 0xF0, 0xE0, 0xC0, 0x80, and 0x00). If a character is received, an ACK is immediately sent back to the MCU. After the MCU recognizes this answer, it enters the next phase, [Slave frequency calibration](#).

2.2.2 Known MCU communication speed

If the frequency is certain (known at compile time), the MCU will be configured to match exactly the communication speed of the PC. All characters are received correctly without any distortion.

The MCU sends 0xFC to the PC, which immediately sends an ACK to the MCU. After the ACK is received, the MCU also (formally) enters the [Slave frequency calibration](#) phase.

2.3 Slave frequency calibration

During this phase, the MCU clock is calibrated. Until now, the PC has communicated with the MCU at a speed that could be from 33% to 300% tolerance. During this phase, the MCU communication speed must be adjusted to match the PC communication speed.

After the PC enters the calibration phase, the no-break timeout starts. If a correct ACK character (0xFC) is not received within this period, a break character is sent at the communication data rate.

A break character consists of 10 consecutive logical zeros. For example, at a 9600 bd rate, its high-low-high pulse lasts $10 \times 104 \mu\text{s} = 1.04 \text{ ms}$.

The MCU then measures the break character length and determines whether its clock is too fast or too slow. The MCU then makes an adjustment to its system clock (or an adjustment of receive routines if, for example, software serial communication is used). This can be repeated as many times as required for the MCU to achieve the proper clock speed.

NOTE: Virtual ports workaround

Most of the users are using **virtual serial ports** and some of these standards are not able to transfer break calibration character. For this reason, new feature using zero calibration character was added in place of the break character pulse ([Figure 4](#)). A zero calibration character consists of nine consecutive logical zeros.

The calibration feature with zero character is implemented in master application as “short TRIM” (checkbox “short TRIM”, [Master applications user guides](#)). The target must be configured for using short calibration (trim) pulse.

After the MCU is calibrated to the correct clock (or after the receive routines are calibrated), the ACK character is sent to the PC to stop sending calibration characters ([Figure 4](#)).

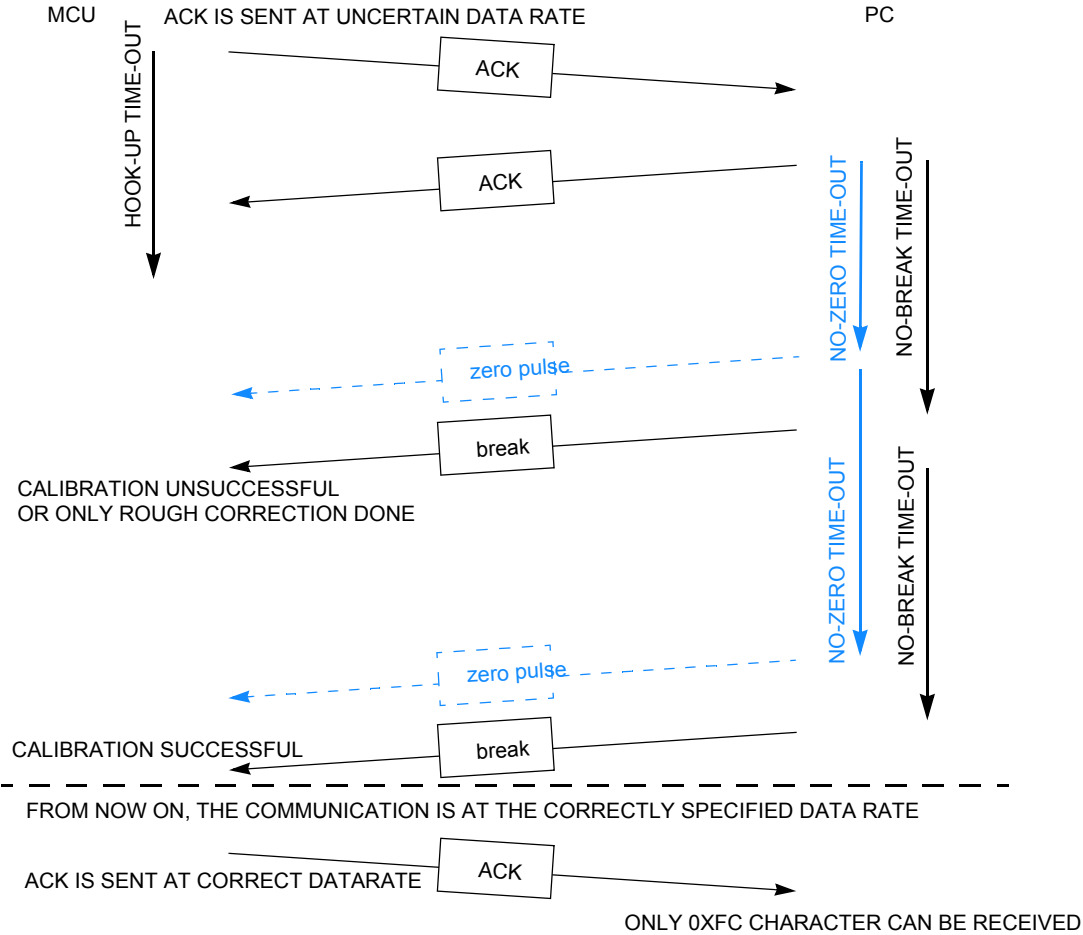

Figure 4. StartUp communication with calibration

If the MCU is operating at the correct data rate (no calibration is possible or required, and the MCU clock is crystal driven), the PC can immediately send an ACK, skipping the calibration phase entirely (Figure 2).

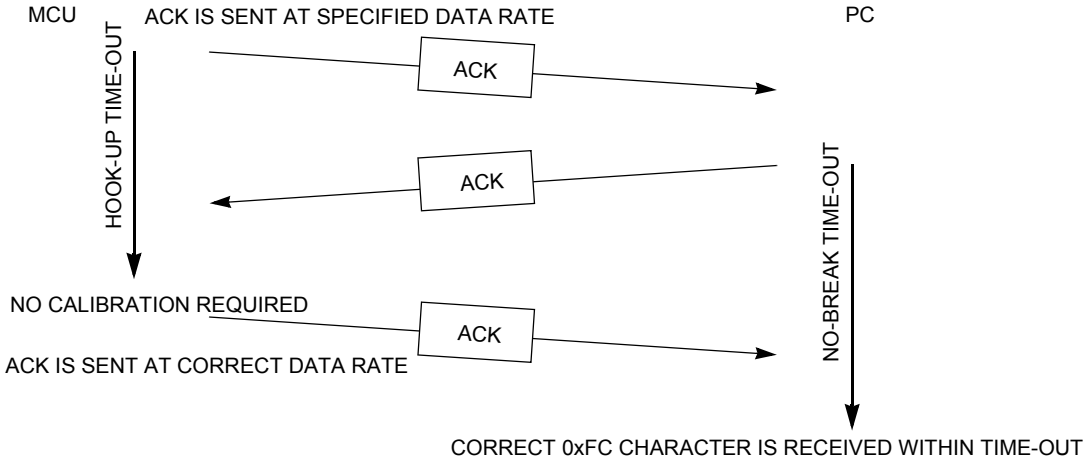

Figure 5. Start-Up communication without calibration

2.4 Interpreting MCU commands

After communication between MCU and PC is established, then MCU enters the main command interpreter loop. The MCU executes simple commands to reprogram its own nonvolatile memory. The communication is conducted on a master-slave mechanism: the PC issues the commands, the MCU executes them and acknowledges the completion of each command either by data or single ACK character.

The minimal set of commands is composed of:

- [Ident command](#)
- [Quit command](#)

Two more basic commands are implemented for pure reprogramming:

- [Erase command](#)
- [Write command](#)

If the user needs a verification feature, one additional (read) command must be compiled into the MCU code. This command is not required for pure reprogramming purposes (minimal configuration).

- [Read command](#)

CRC safety protocol implementation

The protocol provides option to switch on CRC safety for all messages. For CRC is used standard 16 bit implementation CCITT16 and as reset value is used 0xFFFF.

Example value for erase command:

```
'E'-1byte - 0x45
'start address' - 2 bytes - 0x1234
'CRC - 2 bytes' - 0x2907
```

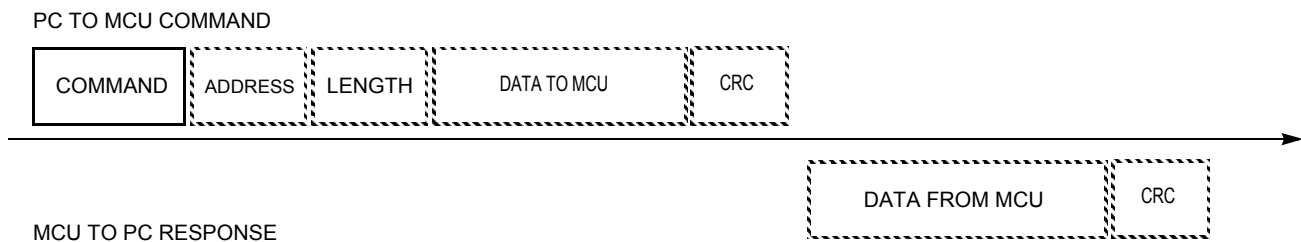

* Dashed fields are not always implemented, data from the MCU may contain only an ACK character instead.

Figure 6. Typical command and response

2.4.1 Ident command

The ident command (coded as 'I', \$49) has no additional fields.

This command is immediately issued by the PC after communication is established. The purpose of the ident command is to notify the PC about several basic properties of the MCU being programmed. All multibyte fields are sent with MSB first.

- Version number and capability table - 1 byte

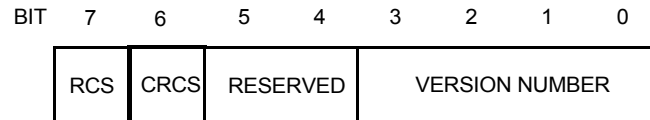

Figure 7. Version number and capability table

- RCS - The Read Command Supported (RCS) flag informs the PC if the read command is supported (implemented). If not, all calls to the read routine are ignored by the MCU and no response is sent back to the PC. The PC software warns the user that no read capabilities are available.
 - Supported - Not supported (usually due to memory constraints)
- CRCS - The CRC Serial Protocol Supported flag informs the PC that all rest communication (including Ident command) is secured by CRC-CCITT checksum.
 - Supported¹ - Not supported (usually due to memory constraints)
- RSVD - These bits are reserved for future use, unused, and should be set to 0.
- VER — Protocol Version

2.4.2 FC protocol version 1 (M68HC08)

Version 1 of the protocol is for M68HC08 MCUs. Additional fields in version 1 are defined as follows:

- Start address of reprogrammable memory area - 2 bytes.
- End address of reprogrammable memory area + 1 - 2 bytes.
- Address of [Bootloader user table](#) - 2 bytes.
- Start address of MCU interrupt vector table - 2 bytes.
- Length of MCU erase block - 2 bytes.
- Length of MCU write block - 2 bytes.
- Bootloader data (specific bootloader information, see device-specific implementation; compared in [Table 2](#)) - 8 bytes.
- Identification string, zero terminated - <n> bytes.
- If the CRC capability of serial protocol is enabled, then follows CRC-CCITT checksum - 2 bytes.

¹.Available since Q3 2011

FC protocol description

PC TO MCU COMMAND

I (\$49)

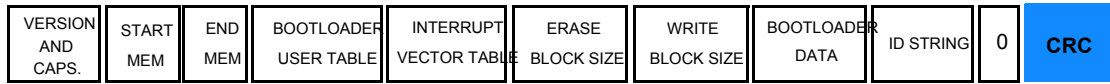

MCU TO PC RESPONSE

Figure 8. Ident command (FC protocol version 1, M68HC08)

2.4.3 FC protocol version 2 (HCS08) and FC protocol version 3 (large M68HC08)

Version 2 of the protocol is for HCS08 MCUs; version 3 is for large M68HC08 (HC08 with two or more FLASH memory banks). In both versions, additional fields are defined as follows:

- System device Identification register content — 2 bytes (unused in protocol version 3, coded as \$FFFF)
- Number of reprogrammable memory areas (N) - 1 byte
- Start address of reprogrammable memory area #1 - 2 bytes
- End address of reprogrammable memory area #1 + 1 - 2 bytes
- Start address of reprogrammable memory area #2 - 2 bytes
- End address of reprogrammable memory area #2 + 1 - 2 bytes
- Start address of reprogrammable memory area #N - 2 bytes
- End address of reprogrammable memory area #N + 1 - 2 bytes
- Address of relocated interrupt vector table - 2 bytes
- Start address of MCU interrupt vector table - 2 bytes
- Length of MCU erase block - 2 bytes
- Length of MCU write block - 2 bytes
- Identification string, zero terminated - <n> bytes
- If the CRC capability of serial protocol is enabled, then follows CRC-CCITT checksum - 2 bytes

PC TO MCU COMMAND

I (\$49)



MCU TO PC RESPONSE

Figure 9. Ident command (FC protocol versions 2 and 3, HCS08)

2.4.4 Erase command

The erase command (coded as 'E', \$45) has only address field, length or data fields are not present. The start address is a 2-byte field, MSB first. If the CRC capability of serial protocol is enabled, then the 16 bits(2 bytes) follows with CRC-CCITT checksum.

The MCU erases the address block where the specified address resides. The length of block to be erased is equal to the erase-block size (typically depends on hardware).

After the MCU completes execution of the command, the ACK (\$FC) character is sent to the PC. If the CRC capability of serial protocol is enabled, then the 16 bits(2 bytes) follows with CRC-CCITT checksum. The erase command's minimum and maximum execution times are not specified.

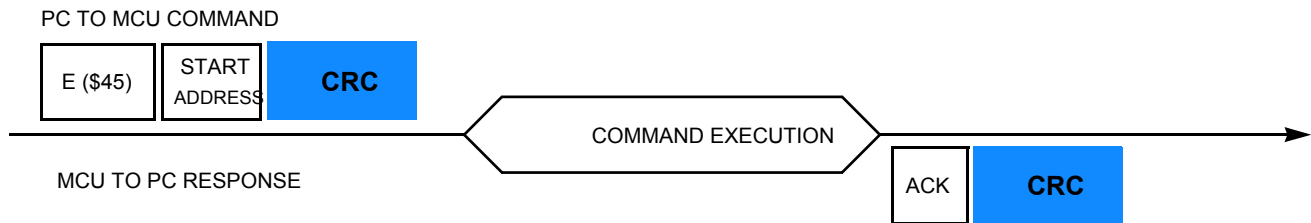

Figure 10. Erase command

2.4.5 Write command

The write command (coded as 'W', \$57) has both address and data fields. The address contains the first address to be programmed. The first byte is the length followed by the number of bytes to be programmed. The start address is a 2-byte field, MSB first and the length is a 1-byte field. If the CRC capability of serial protocol is enabled, then the 16 bits(2 bytes) follows with CRC-CCITT checksum.

After the MCU completes execution of the command, the ACK (\$FC) character is sent to the PC. If the CRC capability of serial protocol is enabled, then the 16 bits(2 bytes) follows with CRC-CCITT checksum. The write command's minimum and maximum execution times are not specified.

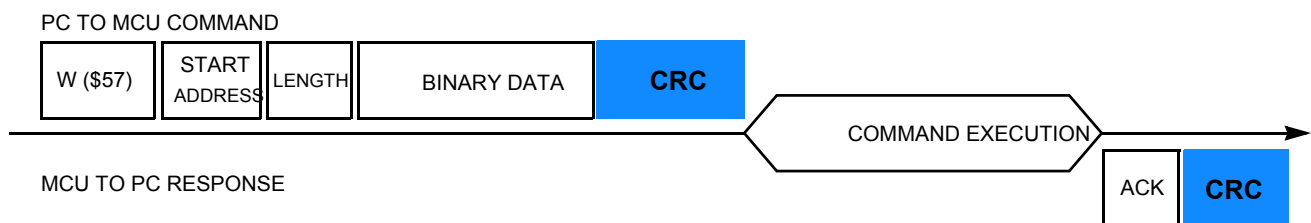

Figure 11. Write command

2.4.6 Read command

The read command (coded as 'R', \$52) has address and data fields. The address contains the first address to be programmed; the single byte is the length of data to be read. The start address is a 2-byte field, MSB first and the length is a 1-byte field. If the CRC capability of serial protocol is enabled, then the 16 bits(2 bytes) follows with CRC-CCITT checksum.

The MCU sends this number of read bytes to the PC. If the CRC capability of serial protocol is enabled, then the 16 bits(2 bytes) follows with CRC-CCITT checksum.

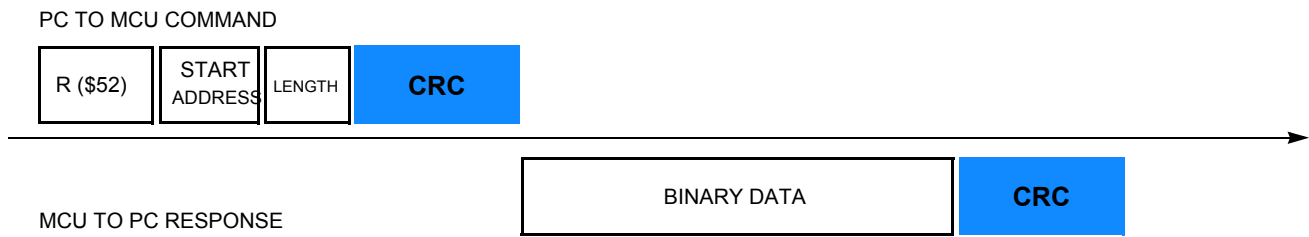

Figure 12. Read command

2.4.7 Quit command

The quit command (coded as ‘Q’, \$51) has no address or data fields. Execution of bootloader code is immediately finished, and the user code is started. No ACK (\$FC) character is sent to the PC.

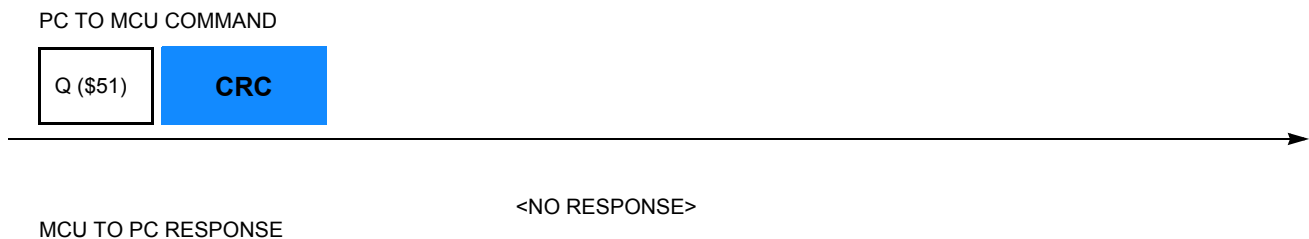

Figure 13. Quit command

2.4.8 Bootloader user table

The bootloader user table is a reprogrammable memory area intended for storage of bootloader-specific data. This memory area is unavailable for the user program. For this table’s memory allocation, refer to [FC protocol, version 1, M68HC908 implementation](#).

3 FC protocol, version 1, M68HC908 implementation

This section describes features specific to the M68HC908 bootloader implementation. The memory allocation is heavily MCU specific, so the meaning of all variables is explained in this section in detail.

Figure 14 shows the typical memory allocation for M68HC908 MCUs with the bootloader preprogrammed. For example, the MC68HC908KX8 MCU memory map includes:

- 7680 bytes of FLASH memory (\$E000–\$FDFF)
- 192 bytes of random-access memory (RAM) (\$0040–\$00FF)
- 36 bytes of user-defined vectors (\$FFDC–\$FFFF)

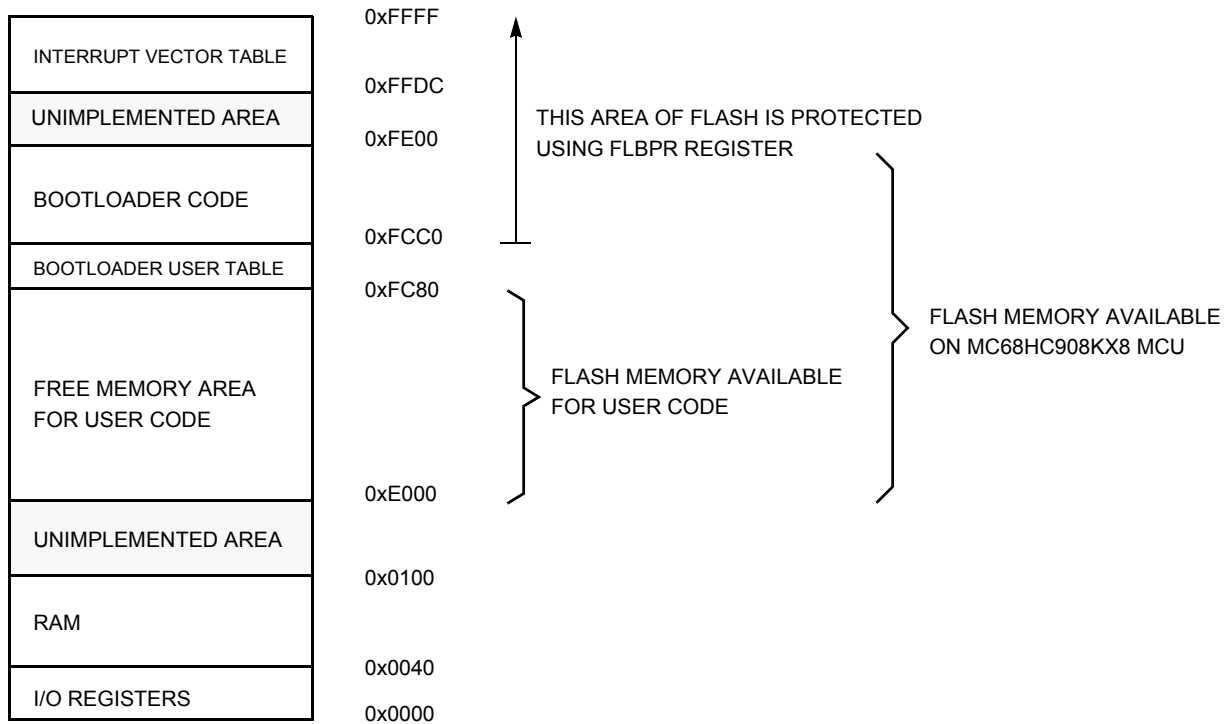

Figure 14. Simplified example of memory allocation in MC68HC908KX8

3.1 Memory allocation

The bootloader code occupies the top-end of FLASH memory (the highest memory address space). This placement allows an effective use of the FLASH block protection technique (see the specific MCU data sheet for details).

3.2 FLASH Block Protection Register (FLBPR)

By setting a FLBPR (FLASH block protection register), all address space above this address is protected from intentional and unintentional erasing/rewriting. After both bootloader and FLBPR register are programmed into memory, the bootloader code is protected from unintentional modification by user code.

NOTE

Some M68HC908 MCUs have an FLBPR register in RAM instead of FLASH (for example, the MC68HC908JK/JL Families). The bootloader code sets this register properly but the user code can eventually modify FLBPR and erase/write the bootloader code. See [FLBPR not usable \(in some M68HC08 family MCUs\)](#).

For example, the MC68HC908KX8 bootloader to the PC memory allocation is:

- \$01 - Version 1, read command not implemented (bit 7).
- \$E000 - Start address of reprogrammable memory area.
- \$FC80 - End address of reprogrammable memory area + 1.

- \$FC80 - Address of [Bootloader user table](#).
- \$FFDC - Start address of MCU interrupt vector table.
- \$0040 - Length of MCU erase block.
- \$0020 - Length of MCU write block.
- 0,0,0,0,0,0,0,0 - Bootloader data. No strictly defined syntax; different M68HC08 implementations provide different values (for example, the sixth value in the MC68HC908KX8 implementation is the value of the internal clock generator [ICG] trim register after calibration). All these bootloader data are then programmed back into the bootloader user table and can be retrieved during all subsequent starts (for example, to trim the MCU's ICG to the best-known value before user code start).
- 'KX8-IR',0 - Identification string, zero terminated. Information to be displayed on PC screen.

3.3 Interrupt vector table relocation

Because the FLASH block protection technique also protects the interrupt vector table from being overwritten, some method must be used to relocate these vectors to the different locations. To do this, the bootloader user table is used. It is a part of memory not protected by the FLBPR, but it is unavailable to the user program. All standard interrupt vectors are pointing to this table where JMP instructions are expected to be stored for each interrupt. The only exception is the reset vector that points to the bootloader code start. When an interrupt occurs, the vector is fetched from protected memory and directs execution to continue at the corresponding JMP instruction in the bootloader user table.

The following figure shows interrupt vector table relocation for M68HC08 MCUs.

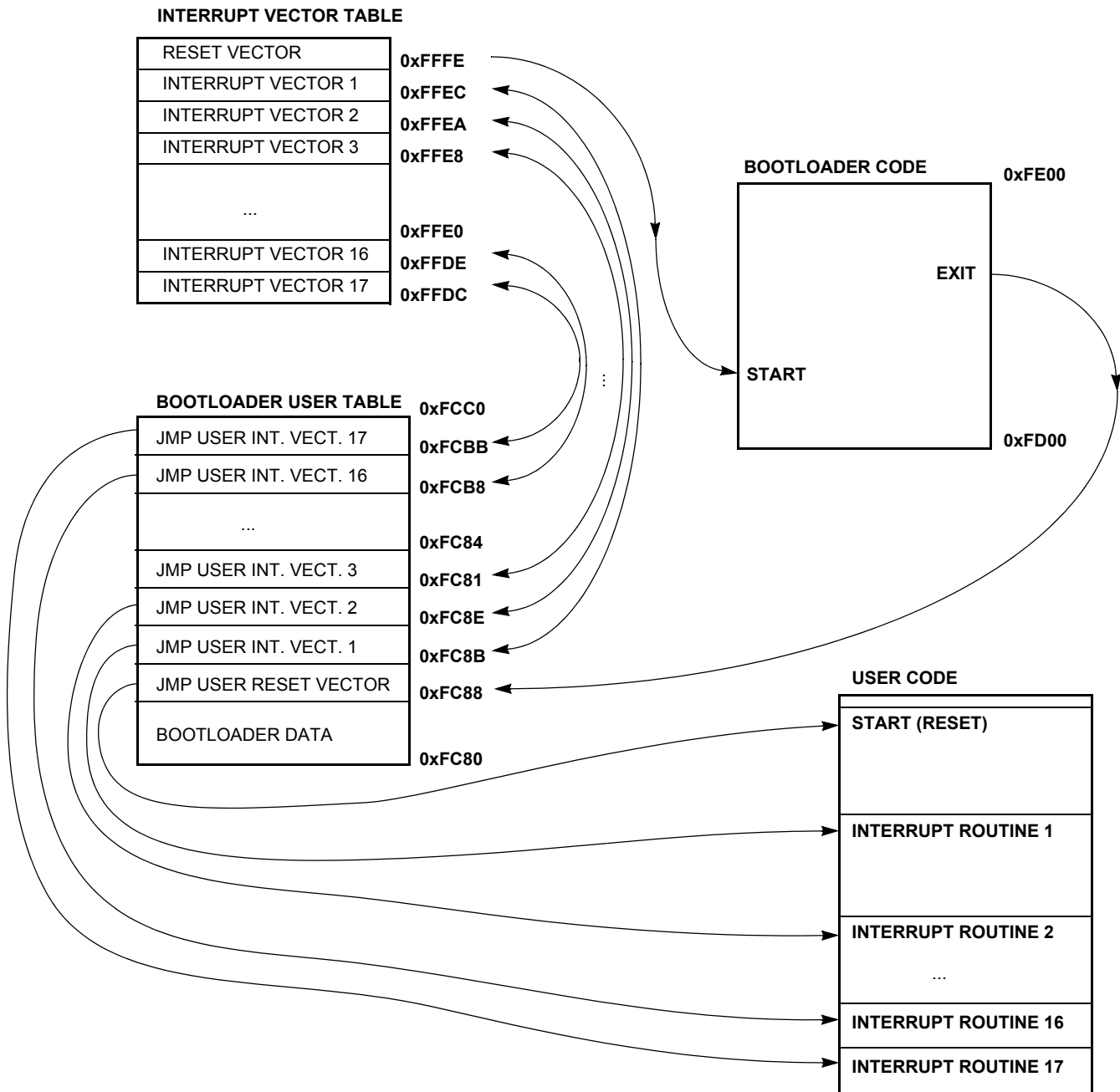

Figure 15. Interrupt vector table relocation (M68HC08 MCUs)

NOTE

In a standard interrupt vector table, each record is 2 bytes long (each vector is a 16-bit address). This is different from the bootloader user table, for which each record is 3 bytes long - a JMP opcode (\$CC) plus a 16-bit address.

3.3.1 S19 file

Because the bootloader operation must be transparent to the user S19 file, another piece of intelligence is built into the PC master code (instead of the MCU slave). The relocation works as follows:

If the data from an S19 record corresponds to an address in the interrupt vector table, the value is relocated into the corresponding area in the bootloader user table, including a JMP instruction (opcode \$CC). For example, if the user S19 file contains #3 interrupt vector \$E123 at address \$FFE8, such a vector is relocated into the sequence \$CC, \$E1, \$23 (JMP \$E123) programmed to the \$FC81 address in the bootloader user table.

Using this method, the user S19 file does not need to be modified, but the lower address of the end of FLASH memory must be considered. In addition, this JMP instruction (3T) delays every interrupt, as explained in [Each interrupt 3T delayed](#).

3.4 User code start

The user code is started in an unusual way to provide a register setup similar to how it appears after MCU reset.

3.4.1 Software reset

If the bootloader must quit and run user code, an illegal operation is intentionally executed (M68HC08 illegal opcode \$32). This causes an illegal operation reset, and the MCU restarts. During bootloader startup, the System Integration Module (SIM) Reset Status Register (SRSR) is tested. If a power-on-reset is not detected, the user code is started instead of the bootloader code. This allows the transparent operation of all other resets (such as illegal address, and so forth) with only a short additional delay caused by testing the SRS register and executing associated jump instructions.

3.4.2 Hardware reset

In some implementations, a pin reset (caused by external reset pin) is also included as a valid source of reset for the bootloader to start. This allows remote in-circuit reprogramming in embedded applications able to drive the M68HC08 reset pin.

Another test has been added to the real bootloader application: if no reset source is detected (that is, if the SRS register is 0), the bootloader is selected by default. This may happen when an external pin causes reset, but the reset pulse is shorter than specified. In that case, the minimum length of reset pulse that will cause reset is shorter than the length needed for the proper propagation of the external reset flag to the SRS register.

Because the SRS register is one-time readable (it clears after read), no subsequent reads of this register provide a valid value. See [M68HC08 system limitations](#) for details.

3.5 M68HC08 system limitations

This section summarizes limitations that must be considered when using the bootloader with the user application.

3.5.1 Memory occupied

One of the most important requirements is to use the smallest code possible. Typical M68HC908 implementations are between 300 to 500 bytes, including the bootloader user table. If the target M68HC08 MCU is capable of FLASH programming using internal ROM routines, the memory consumption is near the lower limit. Larger M68HC08 MCUs (which are not usually equipped with ROM code for FLASH programming) will require approximately 500 bytes of FLASH of the total 32 KB (as is the case with the MC68HC908GP32).

The bootloader is placed at the upper end of FLASH memory; therefore, the only modification required in the user code is in the memory mapping (typically found in the linker parameter file).

The M68HC08 MCU signals the actual available FLASH addresses. The PC Bootloader software will not allow programming if the user code overlaps with bootloader code.

3.5.2 Time delay upon startup and initial communication

The number of pins with specific meanings during bootloader startup must be as small as possible. Especially in communication systems (for example, those using a standard serial port), pin overhead is zero and a “*certain level character at a certain time*” method is used. So, the bootloader waits a certain amount of time to receive an answer from the PC at startup. If none is received, the user code starts. The typical delay is in the range of several hundred milliseconds.

If this startup delay becomes an issue for the final application, the user may modify the bootloader code and use a “*certain level on a certain pin*” method instead. A simple test of the voltage level on the IRQ pin (or any other input pin) can be used to indicate whether the bootloading sequence is required.

3.5.3 Each interrupt 3T delayed

Every interrupt call is delayed by 3T bus clocks required to execute the JMP instruction stored in the bootloader user table. This interrupt vector relocation (as described in [Interrupt vector table relocation](#)) has been chosen as the best solution for achieving user code transparency and security of the bootloader code.

The interrupt latency is about 10 to 15T (assuming that no interrupt is being executed), so this additional delay is not significant for the most applications.

3.5.4 FLBPR not usable (in some M68HC08 family MCUs)

The bootloader uses a FLASH block protection technique to protect itself from being overwritten (where applicable; see [FLASH Block Protection Register \(FLBPR\)](#) for details).

Some M68HC08 MCUs (such as the KX, GP, and GR devices) have this FLASH block protection register stored in FLASH, so it cannot be modified in user mode. The FLBPR can be erased or programmed only

with an external voltage, V_{TST} , present on the IRQ pin (normal monitor mode). Because this feature is completely dedicated to bootloader code protection, it is unavailable to the user application code. If the value for FLPBR appears in the user S19 code, a warning is displayed. Such an occurrence should be omitted from user S19 code.

Some families have the FLASH block protection register stored in RAM instead (the MC68HC908JK/JL Families are like this). The bootloader sets the correct value at the beginning of its execution to protect itself. However, user code can modify this register and protect its own memory areas as needed. This also implies that the bootloader is not 100% protected from user code.

See the specific MCU data sheet for a detailed explanation.

3.5.5 SRS register unusable

The bootloader uses an SRS register (as described in [User code start](#)) to recognize the reset source to determine whether the user code will run. Because the SRS register is one-time readable (that is, it is reset after first read), the user code does not have access to the SRS register value (if the bootloader is present in the memory and makes the first read after each reset). There is no simple solution for this situation. After the SRS register is read by the bootloader, it is stored in one RAM location. Its memory location may differ from one implementation to another. If the application requires the SRS register and bootloader, the user must redirect the SRSR reading to this specific RAM location. This location can be obtained from the bootloader's MAP file.

4 FC protocol, version 2, HC9S08 implementation

This section describes features that are specific to the HC9S08 bootloader implementation. The memory allocation is heavily MCU specific so the meaning of variables is explained in this section.

[Figure 16](#) shows the memory allocation typical to the HC9S08 devices with the bootloader preprogrammed. For example, the MC9S08GB/GT60 device memory map includes:

- 60 KB of FLASH memory (\$1080–\$17FF, \$182C–\$FFAF)
- 4 KB of random-access memory (RAM) (\$0080–\$107F)
- 16 bytes of nonvolatile registers (\$FFB0–\$FFBF)
- 64 bytes of user-defined vectors (\$FFC0–\$FFFF)

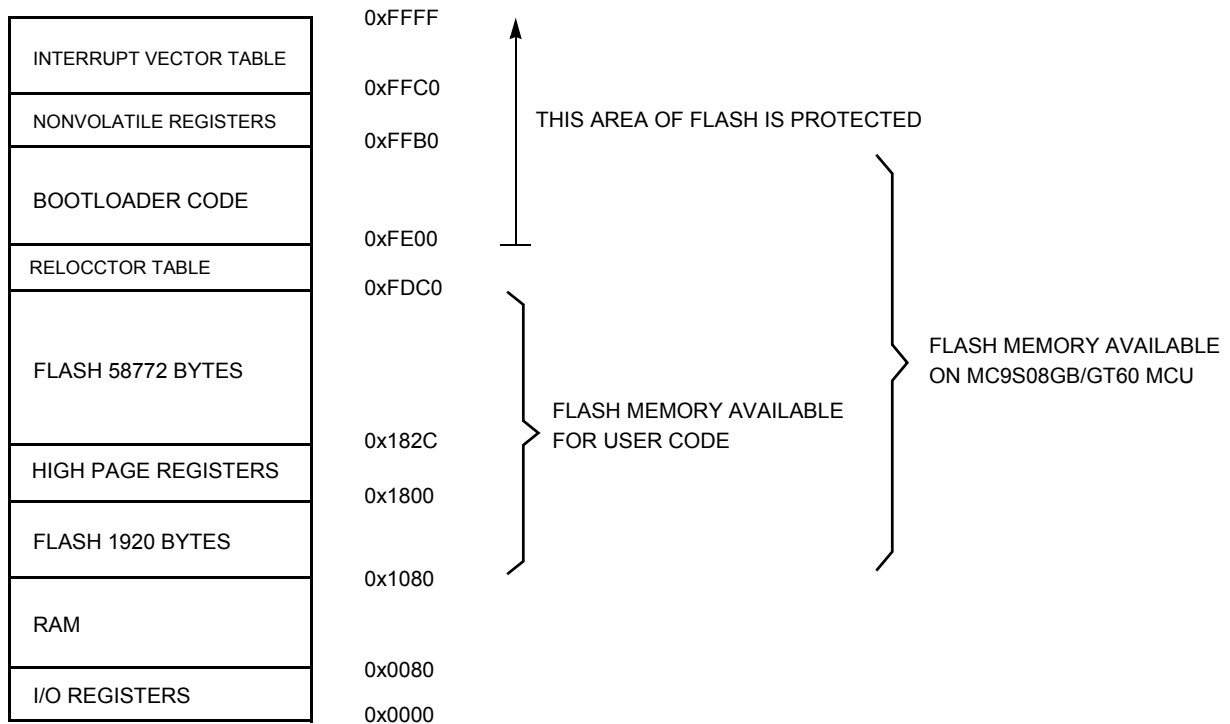

Figure 16. Simplified example of memory allocation in MC9S08GB/GT60

4.1 Memory allocation

The bootloader code occupies the top-end of FLASH memory (the highest memory address space). This placement allows an effective use of the FLASH protection technique (see MCU specific data sheet for details).

4.2 FLASH protection

By setting a FLASH protection register, all address space above this address is protected from both intentional and unintentional erasing/rewriting. After the bootloader and the FLASH protection register are programmed into memory, the bootloader code is protected from unintentional modification by user code.

NOTE

See [FLASH protection technique not usable](#) for limitations.

4.3 Example memory allocation

Examples of the MC9S08GB/GT60 bootloader to the PC memory allocation are as follows:

- \$82 - Version 2, read command implemented (bit 7)
- \$r002 - System device identification register (SDIDR) content (\$002 for GB/GT Family, r (four top bits) is chip revision number reflecting current silicon level
- \$02 - Number of reprogrammable memory areas

- \$1080 - Start address of reprogrammable memory area #1
- \$1800 - End address of reprogrammable memory area #1 + 1
- \$182C - Start address of reprogrammable memory area #2
- \$FDC0 - End address of reprogrammable memory area #2 + 1
- \$FDC0 - Address of relocated interrupt vector table
- \$FFC0 - Start address of MCU interrupt vector table
- \$0200 - Length of MCU erase block
- \$0040 - Length of MCU write block
- 'GB/GT60',0 - Identification string, zero terminated. Information to be displayed on PC screen

4.4 Interrupt vector table relocation

The reset and interrupt vectors would be protected if the flash protection is enabled. Vector redirection (HCS08 hardware feature) allows the user to modify memory allocation of interrupt vector information.

Vector redirection is enabled by programming the NVOPT (nonvolatile option) register. For redirection to occur, at least some portion but not all of the FLASH memory must be block-protected by programming the NVPROT (nonvolatile protection) register. All the interrupt vectors (memory locations \$FFC0–\$FFFD) are redirected except the reset vector (\$FFFE:FFFF).

For example, if 512 bytes of FLASH are protected, the protected address region is from \$FE00 through \$FFFF. The interrupt vectors (\$FFC0–\$FFFD) are redirected to the locations \$FDC0–\$FDFD.

For example, if an SPI interrupt is taken, the values in the locations \$FDE0:FDE1 are used for the vector instead of the values in the locations \$FFE0:FFE1. This allows the user to reprogram the unprotected portion of the FLASH with new program code, including new interrupt vector values while leaving the protected area, which includes unchanged default vector locations.

4.4.1 S19 file

Because bootloader operation must be transparent to the user S19 file, another piece of intelligence is built into the PC master code (instead of the MCU slave). If the record in the interrupt vector table is detected in the user S19 file, the vector is relocated into the corresponding area in the relocated interrupt vector table. For example, if the user S19 file contains #2 interrupt vector at address \$FFEA, such a vector is relocated to the \$FDEA address in the relocated interrupt vector table.

Using this method, the user S19 file does not need to be modified, but the lower address of the end of FLASH memory must be considered.

The following figure illustrates HC9S08 interrupt vector table relocation:

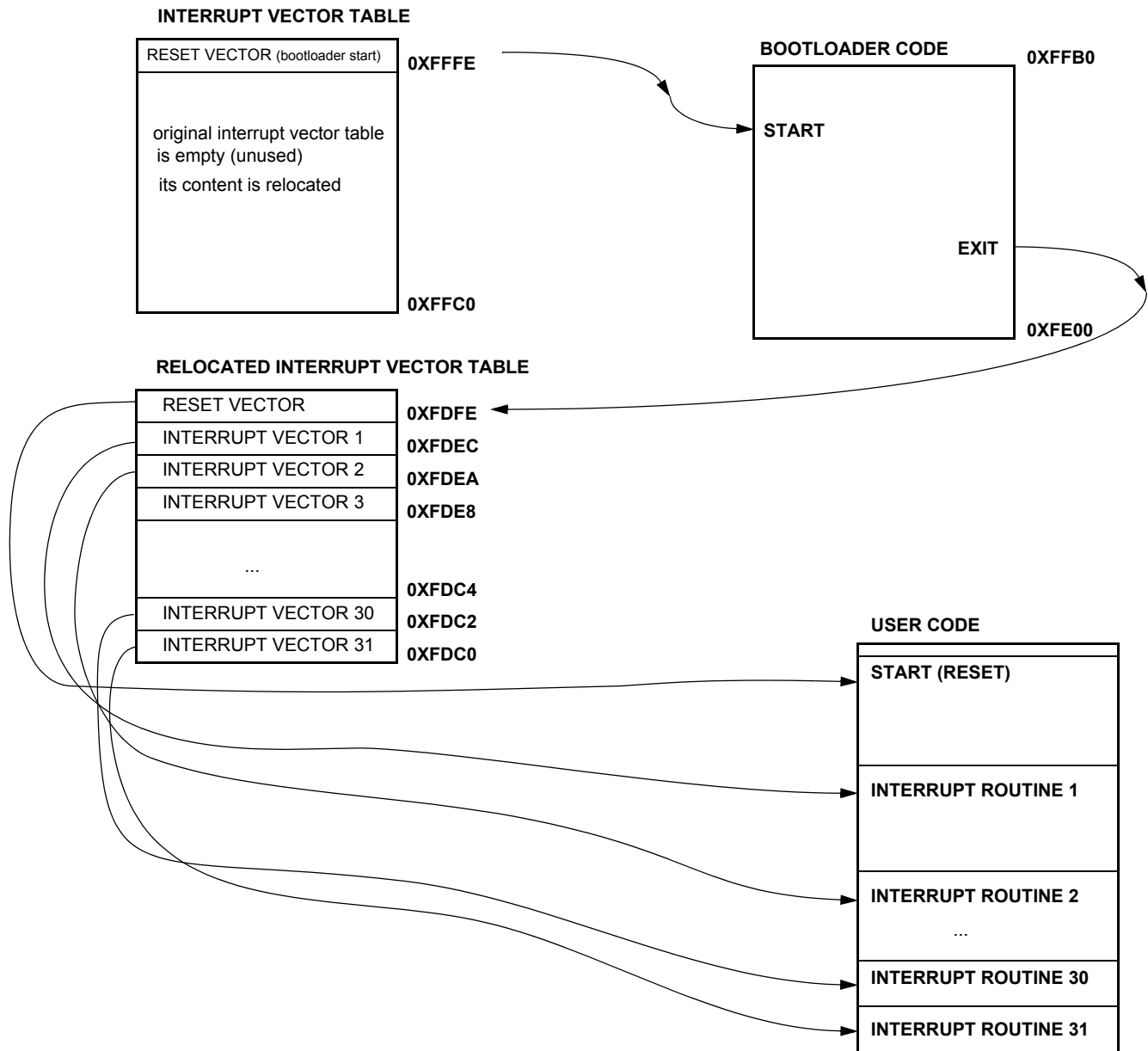

Figure 17. Interrupt vector table relocation explanation (HCS08)

4.5 User code start

To provide a register setup similar to how it appears after MCU reset, the user code is started in an unusual way.

4.5.1 Software reset

If the bootloader must quit and run user code, an illegal operation is intentionally executed (HCS08 illegal opcode \$8D). This causes an illegal operation reset and the MCU restarts. During bootloader startup, the System Reset Status (SRS) register is tested. If a power-on-reset is not detected, the user code starts instead

of the bootloader code. This allows the transparent operation of all other resets (such as illegal address and so forth) with only a small additional delay caused by testing of the SRS register and executing associated jump instructions.

4.5.2 Hardware reset

In some implementations, pin reset (caused by external reset pin) is a valid source of reset for the bootloader to start. This allows remote in-circuit reprogramming in embedded applications that are able to drive the HCS08 MCU reset pin.

4.6 HCS08 system limitations

This section summarizes limitations that must be considered when using the bootloader with the user application.

4.6.1 Memory occupied

One of the strongest requirements is to use the smallest possible code. Typical HC9S08 implementations are 432 bytes (minimal memory size that can be protected) plus another 64 bytes page for relocated interrupt vector table.

The bootloader is placed at the upper-end of FLASH memory, therefore, the only modification required in the user code is in the memory mapping (typically found in the linker parameter file).

The HCS08 MCU signals the actual FLASH addresses available. The PC Bootloader software will warn before programming if the user code overlaps with bootloader code.

4.6.2 Time delay upon startup and initial communication

The number of pins with specific meaning during bootloader startup must be as small as possible. Especially in communication systems (for example, those using a standard serial port), pin overhead is zero and a “*certain character at a certain time method*” is used. So, the bootloader waits a certain amount of time to receive an answer from the PC at startup. If none is received, the user code starts. The typical delay is the range of several hundred milliseconds.

If this startup delay becomes an issue for the final application, the user may modify the bootloader code and use a “*certain level on certain pin*” method. A simple test of the voltage level on the IRQ pin (or any other input pin) can be used to decide whether the bootloading sequence is required.

4.6.3 FLASH protection technique not usable

The bootloader uses a FLASH block protection technique to protect itself from being overwritten, therefore, this feature is not available for the user code. This includes FLASH memory security-related registers (namely NVPROT, NVOPT, and NVBACKKEY) used for protection and interrupt-vector relocation by bootloader.

5 FC protocol, version 3, large M68HC08 implementation

This section describes features specific to the protocol version 3 of the bootloader. This is intended for large HC08s (with two or more FLASH memory banks or, more precisely, with two or more separated FLASH memory areas). The format of the [Ident command](#) from version 2 is used; the rest remains same as with protocol version 1 (HC08) namely [Interrupt vector table relocation](#).

6 FC protocol, version 4, ColdFire (V1)

The protocol version 4 is divided into two versions, version A and version B. The main reason for this separation is the possibility of protecting the bootloader source code. This feature is important for flash programming because protection of the bootloader prevents the source code from being erased. The implementation of version A bootloader is not protected where as the version B implementation is protected.

6.1 Version A (unprotected version)

This section describes the features that are specific to Cold Fire V1 implementation version A. The memory allocation is MCU specific, so the meaning of all variables is explained in this section.

[Figure 18](#) shows the memory allocation typical to the ColdFire V1 devices with the bootloader preprogrammed. For example, the MCF51JM128 device memory map includes:

- 128 KB of FLASH memory (\$00000000-\$0001FFFF)
- 16 KB of random access memory (RAM) (\$00800000-\$00803FFF)
- 16 bytes of nonvolatile registers (\$00000400-\$0000040F)
- 444 bytes of user-defined vectors (\$00000000-\$000001B8)

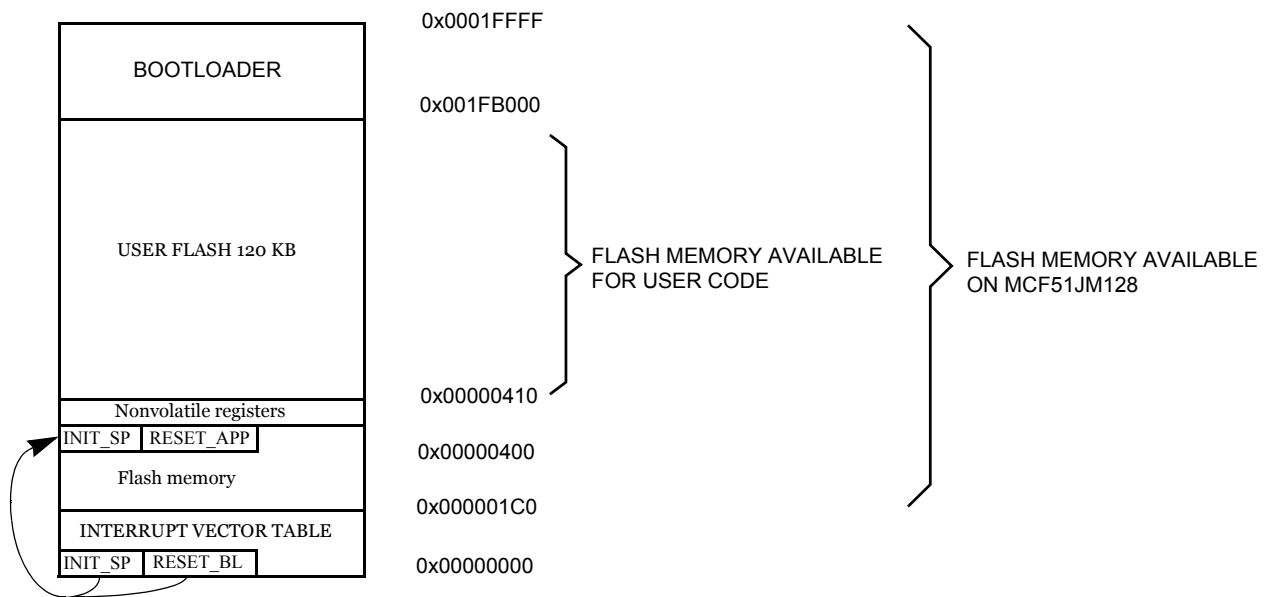

Figure 18. Simplified Example of Memory Allocation in MCF51JM128

6.1.1 Memory allocation

The bootloader code occupies the top of the FLASH memory (the highest memory address space). This placement reduces only the top of the memory space and it is necessary to modify the end of the user application LCF file; see [Memory occupied](#).

6.1.2 FLASH protection

This version of MCU supports a flash protection technique from the beginning of the memory, from address 0x0, for 2 KB sectors.

Flash protection is not implemented in the version A of the protocol, because this version uses the original vector table at address 0x0 for placement of the user vector table.

6.1.3 Example of IDENT command

Example of the memory allocation for the ColdFire (V1) bootloaders are as follows:

- \$84 - Version 4, read command implemented (bit 7)
- \$rC16 - System Device Identification Register (SDIDR) content (\$C16 for JM Family), r (four top bits) is the chip revision number reflecting the current silicon level
- \$02 - Number of reprogrammable memory areas
- \$00000 - Start address of reprogrammable area #1
- \$003FF - End address of reprogrammable area #1 + 1

- \$00410 - Start address of reprogrammable area #2
- \$1FAFF - End address of reprogrammable area #2 + 2
- \$00000 - Address of the relocated interrupt vector table (value 0 means not allocated)
- \$00000 - Start address of the MCU interrupt vector table (value 0 means not allocated)
- \$00400 - Length of the MCU erase blocks
- \$00080 - Length of the MCU write blocks
- 'MCF51xxx/USB' - Identification string, zero terminated. Information to be displayed on the PC screen

The following figure shows the interrupt vector table relocation for ColdFire V1 MCUs:

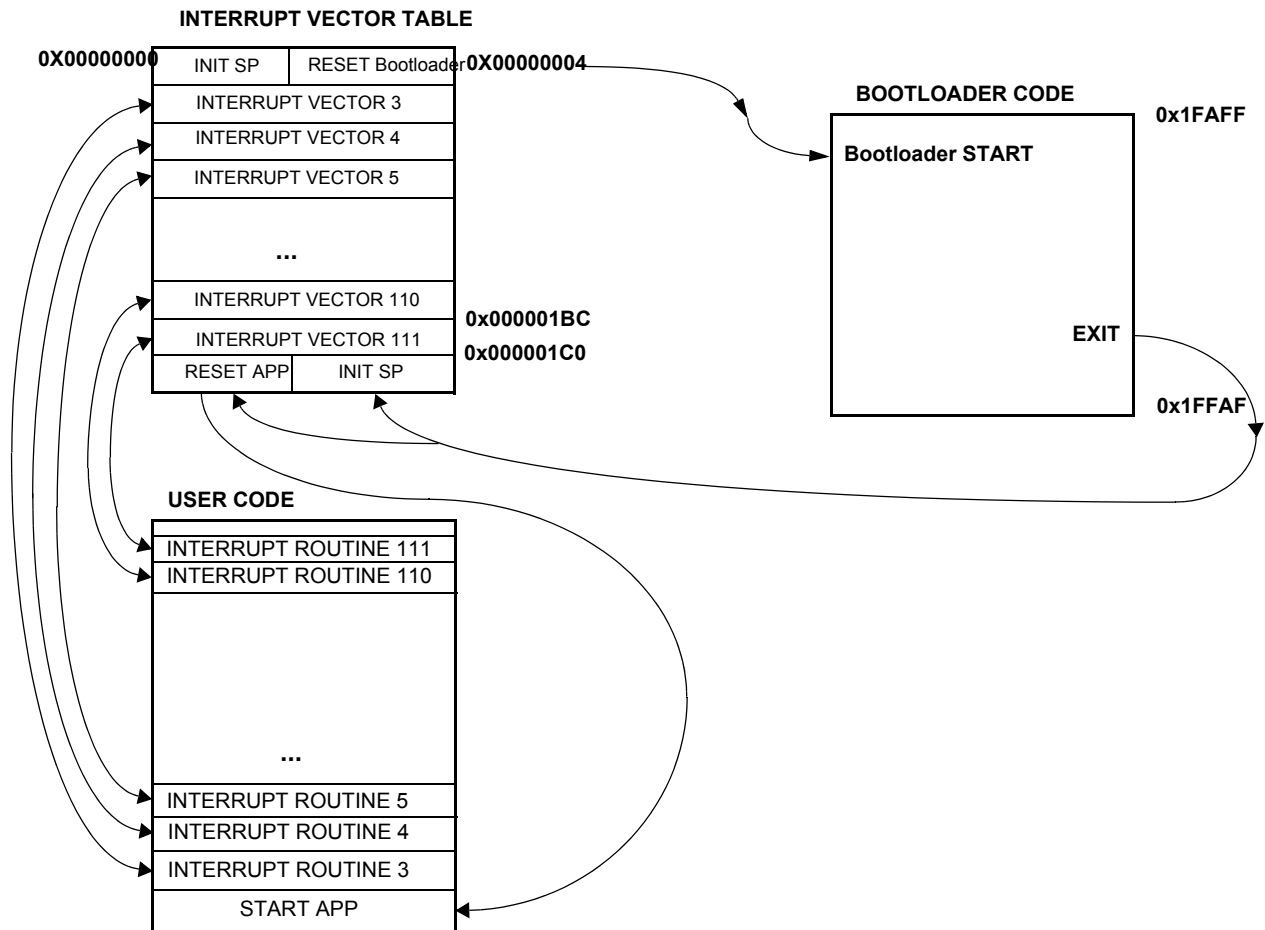

Figure 19. Interrupt Vector Table Relocation Explanation (ColdFire V1 - A)

6.1.4 Software reset

If the bootloader must quit and run user code, an illegal operation is intentionally executed (ColdFire illegal opcode stop #0). This causes an illegal operation reset and the MCU restarts. During bootloader startup, the system reset status register (SRS) is tested. If a power-on-reset is not detected, the user code

starts instead of the bootloader code. This allows the transparent operation of all other resets with only a short additional delay caused by testing of the SRS register and executing associated jump instruction.

6.1.5 ColdFire system limitations

This section summarizes the limitations that must be considered when using the bootloader with the user application.

6.1.5.1 Memory occupied

One major thing is to use the smallest code possible. Typical ColdFire V1 implementations are 1 KB (SCI version) and 8 KB (USB version for JM version). For the USB version, the biggest part of the source code is occupied by the USB drivers (5 KB).

The bootloader limits the top of flash memory, and therefore there must be a modified Linker Command File (LCF) user file. If the LCF file is not set correctly, bootloader will display a warning and the bootloader will be erased. An example of the modification is shown in the following code block:

```
# Sample Linker Command File for CodeWarrior for ColdFire MCF51JM128
# Memory ranges
MEMORY {
    vectors      (RX)  : ORIGIN = 0x00000000, LENGTH = 0x00000200
    application (RX)  : ORIGIN = 0x00000410, LENGTH = 0x0001ABEF //example of memory allocation
    buffer      (RWX) : ORIGIN = 0x00800000, LENGTH = 0x00000100
    userram     (RWX) : ORIGIN = 0x00800100, LENGTH = 0x00003F00
}
```

6.1.5.2 Description of the reset transfer

The original vector 1(INIT SP) and vector 2(RESET) are rewritten to the bootloader's reset and stack pointer initialization values. The value of the beginning of the user application is programmed into address 0x1C0, and the initialization value of the stack pointer into address 0x1C4. These two values are reprogrammed every bootloading cycle to the current application values.

6.2 Version B (protected version)

This section describes features that are specific to the Cold Fire V1 implementation version B. The memory allocation is MCU specific, so the meaning of all variables is explained in this section in detail.

Figure 20 shows the memory allocation typical to the ColdFire V1 devices with the bootloader pre-programmed. For example, the MCF51JM128 device memory map includes:

- 128 KB of FLASH memory (\$00000000-\$0001FFFF)
- 16 KB of random access memory (RAM) (\$00800000-\$00803FFF)
- 16 bytes of nonvolatile registers (\$00000400-\$0000040F)

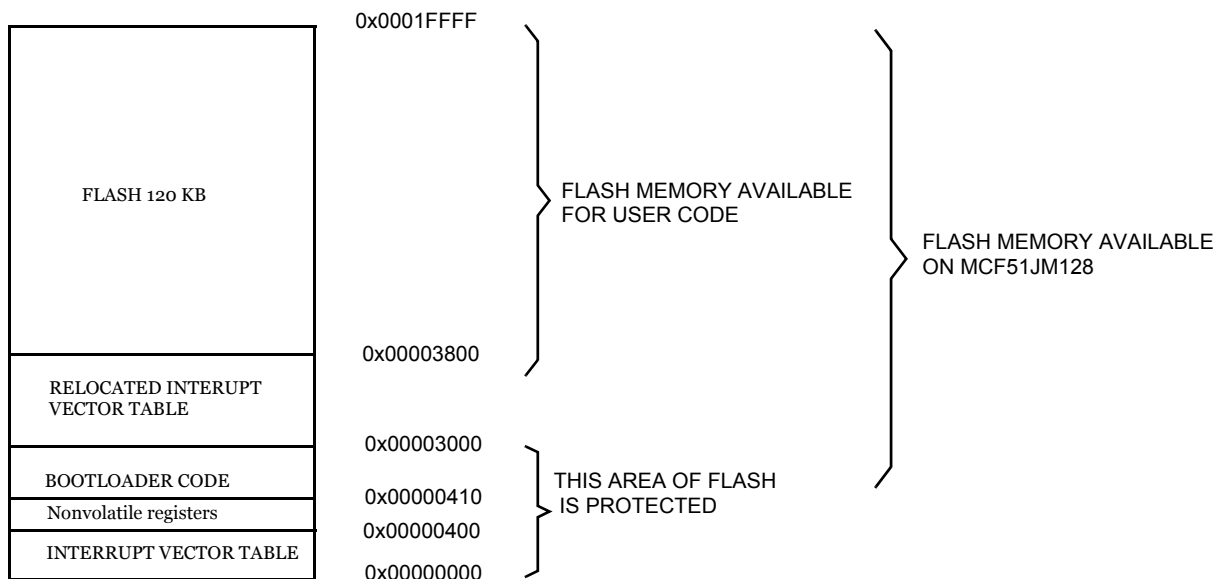

Figure 20. Simplified example of memory allocation in MCF51JM128 version B

6.2.1 Memory allocation

The bootloader code occupies the bottom of FLASH memory in the range 0x0410 to 0x3000 above the original interrupt vector table. This placement moves the start of memory space and for that reason it is necessary to modify the LCF file (see the MCU specific data sheet for details).

6.2.2 FLASH protection

By setting a FLASH protection register (FPROT), all address space under this address is protected from both intentional and unintentional erasing/rewriting. After the bootloader and the FLASH protection register are programmed into memory, the bootloader code is protected from unintentional modification by user code.

6.2.3 Example memory allocation

For example, the memory allocation for the ColdFire (V1) bootloaders is:

- \$84 - Version 4, read command implemented (bit 7).
- \$rC16 - System Device Identification Register (SDIDR) content (\$C16 for the JM Family), r (four top bits) is chip revision number reflecting the current silicon level.
- \$01 - Number of reprogrammable memory areas.
- \$03800 - Start address of the reprogrammable area.
- \$1FFFF - End address of the reprogrammable area +1.

- \$03000 - Address of the relocated interrupt vector table.
- \$001BC - Start address of the MCU interrupt vector table.
- \$00400 - Length of the MCU erase blocks.
- \$00080 - Length of the MCU write blocks.
- ‘MCF51JM128/USB’ - Identification string, zero terminated. Information to be displayed on the PC screen.

6.2.4 Limitations

This section summarizes the limitations that must be considered when using the bootloader with the user application.

6.2.4.1 Memory occupied

This version of bootloader limits the beginning of the flash memory. For this reason, the user must modify the Linker Command File (LCF) and the boundary of the user flash start is moved to address 0x3800. The following code example shows the LCF file for a user application.

```
# Sample Linker Command File for CodeWarrior for the ColdFire MCF51JM128
# Memory ranges

MEMORY {
application (RX) : ORIGIN = 0x00003800, LENGTH = 0x0001C7FF //memory allocation
useram (RWX) : ORIGIN = 0x00800000, LENGTH = 0x00003FFF
}
```

6.2.4.2 Delayed JMP instruction

The next limitation increases delays in the interrupts because there is a double jump instruction feature being used. The complete situation is described in the following figure:

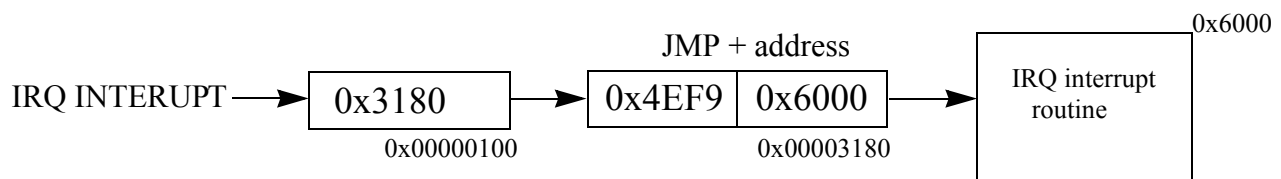

Figure 21. The vector redirection using the JMP instruction

The following figure represents the interrupt vector table relocation explanation (ColdFire V1 - B):

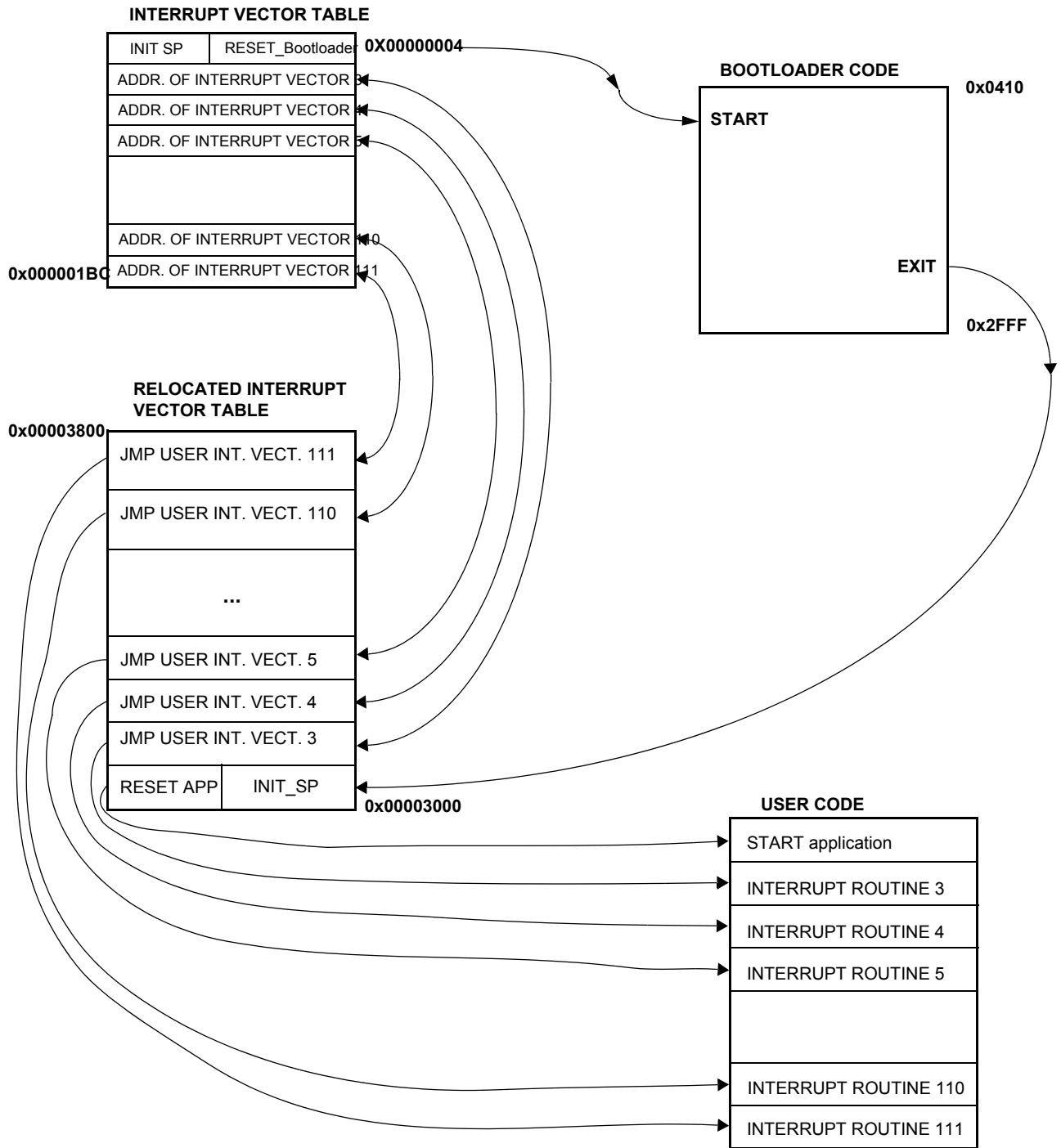

Figure 22. Interrupt vector table relocation explanation (ColdFire V1 - B)

7 FC protocol, version 5, Kinetis

This section describes features specific to the protocol Version 5 of the bootloader. This was created for a better compatibility with new Kinetis families of the MCUs. Protocol 4 for the ColdFire MCUs version B (protected version) is the basis for the Kinetis protocol version 5. The bootloader for the Kinetis MCUs includes an additional capability for CRC control. The memory allocation is MCU specific, so the meaning of all variables is explained in the following subsections.

Figure 23 shows the memory allocation typical to the Kinetis K60 devices with the bootloader preprogrammed. For example, the PK60N512 device memory map includes:

- 495 KB of FLASH memory (\$00004000 - \$0007FFFF)
- 128 KB of random access memory (RAM) (\$001FFE0000-\$002001FFFF)
- 16 bytes of nonvolatile registers (\$00000400-\$0000040F)
- 444 bytes of user-defined vectors (\$00000000-\$000001B8)

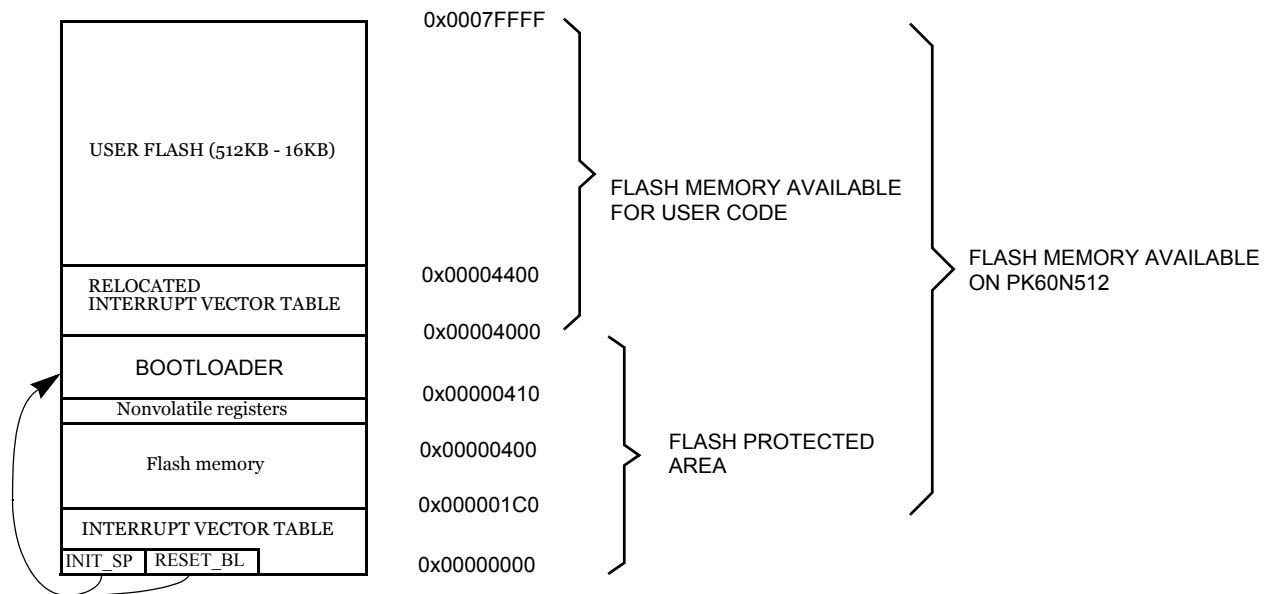

Figure 23. Simplified example of memory allocation in PK60N512

7.1 Memory allocation

The bootloader code occupies the first region of the FLASH memory (the lowest memory address space). This placement moves at the beginning of the available memory space and it is necessary to shift this address in the user application linker files (ICF file in IAR and in LCF file in CodeWarrior). The examples of the ICF and LCF linker files modification are as follows:

Kinetis K60

Example of modification ICF file in IAR6.4

```
// default linker file
define symbol __ICFEDIT_region_ROM_start__ = 0x00000000;
define symbol __code_start__ = 0x00000410;

// modified linker file for Kinetis K60 with 512KB flash memory
define symbol __ICFEDIT_region_ROM_start__ = 0x00004000;
define symbol __code_start__ = 0x000004400;
```

Example of modification LCF file in CodeWarrior 10.2

```
# Default linker command file.
MEMORY {
m_interrupts (RX) : ORIGIN = 0x00000000, LENGTH = 0x000001E0
m_text (RX) : ORIGIN = 0x00000800, LENGTH = 0x00040000-0x00000800
m_data (RW) : ORIGIN = 0x1FFF8000, LENGTH = 0x00010000
m_cfmprotrom (RX) : ORIGIN = 0x00000400, LENGTH = 0x00000010
}

# Modified linker command file.
MEMORY {
m_interrupts (RX) : ORIGIN = 0x00000000, LENGTH = 0x000001E0
m_text (RX) : ORIGIN = 0x00004400, LENGTH = 0x00040000-0x00004400
m_data (RW) : ORIGIN = 0x1FFF8000, LENGTH = 0x00010000
m_cfmprotrom (RX) : ORIGIN = 0x00000400, LENGTH = 0x00000010
}
```

Kinetis KL25

Example of modification ICF file in IAR6.4

```
// default linker file
define symbol __ICFEDIT_region_ROM_start__ = 0x00000000;
define symbol __code_start__ = 0x00000410;

// modified linker file for Kinetis K60 with 512KB flash memory
define symbol __ICFEDIT_region_ROM_start__ = 0x00001000;
define symbol __code_start__ = 0x0000010C0;
```

Example of modification LCF file in CodeWarrior 10.2

```
# Default linker command file.
MEMORY {
m_interrupts (RX) : ORIGIN = 0x00000000, LENGTH = 0x000001E0
m_text (RX) : ORIGIN = 0x00000800, LENGTH = 0x00010000-0x00000800
m_data (RW) : ORIGIN = 0x1FFF8000, LENGTH = 0x00010000
m_cfmprotrom (RX) : ORIGIN = 0x00000400, LENGTH = 0x00000010
}

# Modified linker command file.
MEMORY {
m_interrupts (RX) : ORIGIN = 0x00000000, LENGTH = 0x000001E0
m_text (RX) : ORIGIN = 0x000010C0, LENGTH = 0x00010000-0x000010C0
m_data (RW) : ORIGIN = 0x1FFF8000, LENGTH = 0x00010000
m_cfmprotrom (RX) : ORIGIN = 0x00000400, LENGTH = 0x00000010
}
```

7.2 Interrupt vector table redirection

The FLASH block protection technique also protects the interrupt vector table from being overwritten, so some method must be used to relocate these vectors to the different locations. To do this, the bootloader user table is used.

The boundary where the flash memory begins is moved to address of first unprotected region of flash memory (0x00004000 for Kinetis K60 with 512 KB flash memory) because below this section of memory the protected bootloader is placed.

7.3 FLASH protection

The Kinetis MCU supports flash protection using four 8-bit registers allowing 32 protectable regions. Each bit in these four registers protects a 1/32 region of the program flash memory. For example, for the Kinetis K60 with 512 KB flash memory, the smallest protected area is 16 KB. For the bootloader purposes, protection area of the first flash memory block between addresses \$00000000-\$00003FFF by Kinetis K60 with 512 KB is used.

The following figure represents the system of flash memory protection in Kinetis MCUs:

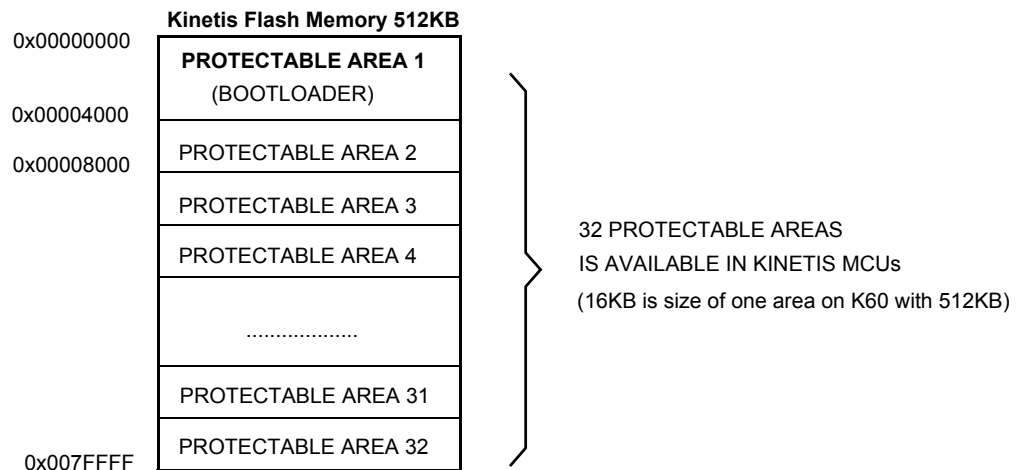

Figure 24. System of flash memory protection in Kinetis MCUs

7.4 Example of IDENT command

Example of the memory allocation for the Kinetis K60 bootloader are as follows:

- \$C8 - Version 5, read command implemented (bit 8), CRC enabled (bit 7)

- \$r14A -System Device Identification Register (SDID) content (\$14A for the K60 Family), r(13-16 bits) is the chip revision number reflecting the current silicon level
- \$01 - Number of reprogrammable memory areas
- \$0004400 - Start address of the reprogrammable area
- \$007FFFF - End address of the reprogrammable area
- \$0000000 - Address of the original vector table (1KB)
- \$0004000 - Address of the new vector table (1KB)
- \$00400 - Length of the MCU erase blocks
- \$0080 - Length of the MCU write blocks

7.5 Software reset

If the bootloader must quit and run user code, an MCU reset operation is intentionally executed by using the system reset sequence bit in register AIRCR (Application Interrupt and Reset Control Register). During bootloader startup, the System Reset Status (SRS) register is tested. If a power-on-reset is not detected, the user code starts instead of the bootloader code. This allows a transparent operation of all other resets with only a short additional delay caused by testing of the SRS register.

7.6 Kinetis system limitations

This section summarizes the limitations that must be considered, when using the bootloader with the user application.

7.6.1 Memory occupied

This version of the bootloader limits the beginning of the flash memory. Due to this, there must be a modified command linker file (ICF) for the target application and the memory boundary of the user flash start moved to an address under protected region (for example to address \$4400 by K60).

The following figure shows the interrupt vector table relocation for Kinetis K60 MCU:

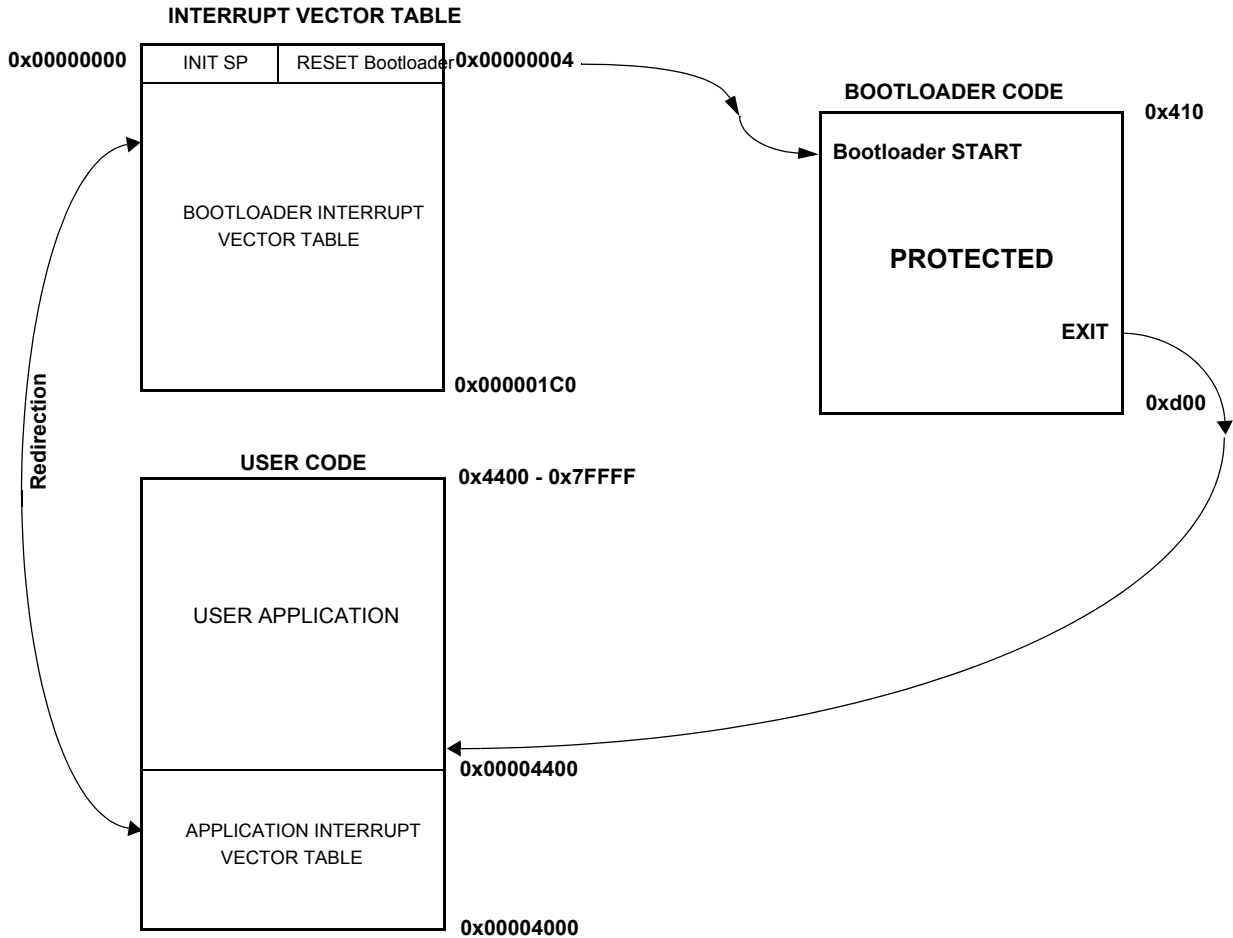

Figure 25. Interrupt Vector Table Relocation Explanation for Kinetis (Version 5)

7.7 Correct setting of configuration file

Bootloader configuration file *bootloader_cfg.h* offers a new feature to the users with using predefined configuration files for many of Kinetis evaluation boards and also allows the user to create any specific configuration.

Configuration file *bootloader_cfg.h* (for example using predefined configuration for TOWER K60 board)

```
#ifndef KINETIS_K
#include "AN2295_TWR_K60_cfg.h"
#endif
```

For the correct function of the bootloader must be defined the following macros (configuration file *AN2295 TWR K60_cfg.h*):

```
/******
```

```

/** USER SETTINGS OF KINETIS MCU */
/** Kinetis ARM Cortex-M4 model */
//K10_50MHz K11_50MHz K12_50MHz K10_72MHz K10_100MHz K10_120MHz
//K20_50MHz K21_50MHz K22_50MHz K20_72MHz K20_100MHz K20_120MHz
//K30_72MHz K30_100MHz
//K40_72MHz K40_100MHz
//K50_72MHz K51_72MHz K50_100MHz
//K60_100MHz K60_120MHz
//K70_120MHz

/** Kinetis ARM Cortex-M0+ model */
//KLO_48MHz
//KL1_48MHz
//KL2_48MHz KL25_48MHz

#define KINETIS_MODEL K60_100MHz

/* in the case of using USB VIRTUAL SERIAL LINK you must activate No break TRIM CHECKBOX in
the master AN2295 PC Application */
/* the break impulse is replaced by using only 9 bits zero impulse */
// BREAK IMPULSE      |START| 10| 10| 10| 10| 10| 10| 10| 10| 10| 10| STOP|
// ZERO IMPULSE       |START| 10| 10| 10| 10| 10| 10| 10| 10| 10| 10| |STOP|

#define BOOTLOADER_SHORT_TRIM 1

Kinetis flash memory can be defined in different sizes and supported sizes are 32, 64, 128,
256, 512 and 1024 KBytes.
#define KINETIS_FLASH FLASH_512K

Following define determines if the bootloader code will be protected or not (protection is
recommended). First section of the flash will be protected (protected_size = flash_size / 32).
protection enabled - 1 , protection disabled - 0
#define BOOTLOADER_FLASH_PROTECTION 1

Flash write access allows change mode of access to flash memory. Each model of MCU can support
different write access. Supported write access macros are defined as follows:

FLASH_WRITE_ACCESS_LONG - 32 Bytes
FLASH_WRITE_ACCESS_PHRASES - 64 Bytes
FLASH_WRITE_ACCESS_DOUBLE_PHRASES - 128 Bytes

#define FLASH_WRITE_ACCESS FLASH_WRITE_ACCESS_PHRASES

Address of base pointer to actual used UART module
#define BOOT_UART_MODULE UART2_BASE_PTR

Range of UART baudrates is between (9600 - 115200 Baud)
#define BOOT_UART_BAUD_RATE 115200

Address of peripheral base pointer for GPIO port (number of GPIO port shared with UART module)
#define BOOT_UART_GPIO_PORT PORTE_BASE_PTR

Setting of multiplexer for UART alternative of the pin
#define BOOT_PIN_UART_ALTERNATIVE 3

Setting of multiplexer for GPIO alternative of the pin
#define BOOT_PIN_GPIO_ALTERNATIVE 1

```

```
Number of UART & GPIO pin for receiver (Rx)
#define BOOT_UART_GPIO_PIN_RX 17

Number of UART & GPIO pin for transmitter (Tx)
#define BOOT_UART_GPIO_PIN_TX 16

/*****/
/* Actual used PIN reset setting */
#define BOOT_PIN_ENABLE_PORT_BASE PORTC_BASE_PTR

#define BOOT_PIN_ENABLE_GPIO_BASE PTC_BASE_PTR

#define BOOT_PIN_ENABLE_NUM 9
```

Following macros allows using of voluntary bootloader features:

Read command feature allows to check the flash memory.

```
#define BOOTLOADER_ENABLE_READ_CMD 1
```

Watchdog timer can be enabled or disabled.

```
#define BOOTLOADER_INT_WATCHDOG 0
```

Verification of memory without CRC functions

```
#define BOOTLOADER_ENABLE_VERIFY 1
```

Verification of memory with CRC functions

```
#define BOOTLOADER_CRC_ENABLE 1
```

Autotrimming function allows to calibrate internal oscillator of MCU. If these feature is not enabled user must define your own clock initialization or trimming of internal oscillator.

```
#define BOOTLOADER_AUTO_TRIMMING 1
```

This feature allows using external pin for the bootloader starting

```
#define BOOTLOADER_PIN_ENABLE 0
```

*****/

/** CALIBRATION OF BOOTLOADER TRIM SETTINGS */

Address of flex timer base pointer

```
#define BOOT_CALIBRATION_TIMER FTM0_BASE_PTR
```

Address of GPIO PORT base pointer

```
#define BOOT_CALIBRATION_GPIO_PORT PTE_BASE_PTR
```

7.8 Quick guide: How to prepare the user Kinetis application for AN2295 bootloader

There are three limitations that must be taken care to modify the user application to be ready to run with AN2295 bootloader:

1. Linker File: The user application has to be moved above the bootloader code. The following rules inform where to move the user application:

- The MCU with bigger/equal flash than 64 KB (2048 B flash protection block): In this case the start of the user application should start on the second protection block plus vector table size. The vector table basically should be placed on the start of second protection block.
 - The MCU with smaller flash than 64KB: In this case the user application should start on 0x800 with interrupt vectors and the application follows above the interrupt table.
 - To modify linker file in more detail, see [Memory allocation](#).
2. Flash configuration registers: The configuration of Flash (protection, security and others) is placed in Kinetis on address 0x400 because this address is placed in area of bootloader code, it should be removed definition of these registers from the user application.
 3. VTOR register: Some user applications setup the VTOR(Vector Table Offset Register) register on startup with default value (0x0000), so the configuration of this register could be removed or updated to point to currently used vector table (In general case is the first byte of user application).

7.9 Using Kinetis bootloader for MQX based application

Kinetis bootloader can be used for programming of MQX based application. This topic explains what has to be done in MQX application to be ready for use with AN2295 bootloader.

The following steps are similar to the user application described in the [Quick guide: How to prepare the user Kinetis application for AN2295 bootloader](#) section, modification of VTOR register does not required by MQX based application.

The following two things must be updated in the MQX project:

1. Linker File: In the linker file of MQX the situation is similar to bare metal user application. The MQX application has to be moved above the AN2295 bootloader code. The MQX Linker file is using as standard linker definition as own some. For example the updated lines from Linker file for K60N512 and IAR6.4 tool:
 - define symbol `__ICFEDIT_intvec_start__ = 0x00004000;`
 - define symbol `__ICFEDIT_region_ROM_start__ = 0x00004000;`
 - define exported symbol `__INTERNAL_FLASH_BASE = 0x00004000;`
 - define exported symbol `__VECTOR_TABLE_ROM_START = 0x00004000;`
2. Flash configuration registers: The setting of the flash configuration registers is simpler in MQX application than in general bare metal application. It is enough to define one MQX macro:
 - `#define BSPCFG_ENABLE_CFMPROTECT 0`

NOTE

There could be with disabling the CFMPPROTECT with some BSP, but this should be solved individually.

8 MCU slave software

This section provides a detailed description of the five typical M68HC(S)08, Cold Fire V1 and Kinetis bootloader implementations. All code is written in assembly language. Several selected targets and different features are described in the following table:

Table 2. Target implementation comparison

MCU Family	FLASH Memory Use (in Bytes)	Clock Source	ROM Routines Usage	Calibration Conducted	SCI	FLASH Erase Page Size (in Bytes)	FLASH Program Page Size (in Bytes)
MC68HC908AP AP8/AP16/ AP32/AP64	592	32768 Hz XTAL or external clock.	Yes, different version	No	Hardware	512	64
MC68HC908AB/AS/AZ AB32/AS32/AZ32 AS60/AZ60	640	4.9152MHz XTAL	No	No	Hardware	128	64
MC68HC908EY EY16	384	ICG	Yes	Yes	Hardware	64	32
MC68HC908GP GP32	512	32768 Hz XTAL or external clock.	No	No	Hardware	128	64
MC68HC908GR GR4/GR8/GR16 GR8A/GR16A	320	32768 Hz XTAL or external clock; 8MHz XTAL (A Family)	Yes	No	Hardware	64	32
MC68HC908GT GT8/GT16	384	ICG	Yes	Yes	Hardware	64	32
MC68HC908GZ GZ8/GZ16	512	8 MHz XTAL	Yes	No	Hardware	64	32
MC68HC908GZ GZ60	512	8 MHz XTAL	No	No	Hardware	128	64
MC68HC908JK/JL JK1/JL1/ JK3/JL3	395	XTAL, RC oscillator or ext. source	Yes	Yes	Software, single-wire possible	64	32
MC68HC908JK/JL JK8/JL8	384	4.9152MHz XTAL	Yes, different version	No	Hardware	64	32
MC68HC908JW JW32	1968	4MHz or 6MHz XTAL or resonator	Yes	N/A	USB2.0	512	64
MC68HC908LB LB8	384	ICG	Yes	Yes	Software, single-wire possible	64	32
MC68HC908LJ LJ12/ LJ/LK24	324	32768 Hz XTAL or external clock.	Yes, different version	No	Hardware	128	64
MC68HC908KX KX2/KX8	384	ICG	Yes	Yes	Hardware	64	32
MC68HC908MR MR8	461	PLL with XTAL (4 MHz)	No	No	Hardware	64	32
MC68HC908MR MR16/MR32	461	PLL with XTAL (4 MHz)	No	No	Hardware	128	64

Table 2. Target implementation comparison (continued)

MCU Family	FLASH Memory Use (in Bytes)	Clock Source	ROM Routines Usage	Calibration Conducted	SCI	FLASH Erase Page Size (in Bytes)	FLASH Program Page Size (in Bytes)
MC68HC908QB QB4/QB8	362/302	QB/QC ICG	Yes	Yes/No	Hardware	64	32
MC68HC908QC QC8/QC16	387/323	QB/QC ICG	Yes	Yes/No	Hardware	64	32
MC68HC908QT/QY QT1/QT4/ QY1/QY4	320	Simpler ICG	Yes	Yes	Software, single-wire possible	64	32
MC68HC908SR SR12	512	32768 Hz XTAL	No	No	Hardware	128	64
MC9S08AW HCS08AW32/48/64	576	HCS08 ICG	No	Yes	Hardware	512	64
HCS08AC8 HCS08AC16 HCS08AC32 HCS08AC48 HCS08AC60	432	HCS08 ICG	No	Yes	Hardware	512	64
HCS08AC128	694	HCS08 ICG	No	Yes	Hardware	512	128
MC9S08GB/GT HCS08GB/GT32 HCS08GB/GT60	576	HCS08 ICG	No	Yes	Hardware	512	64
HCS08QE4 HCS08QE8 HCS08QE16 HCS08QE32	432	HCS08 ICG	No	No	Hardware	512	64
MC9S08QG HCS08QG4/8	576	HCS08 ICG	No	No (HW) Yes (SW)	Hardware Software	512	64
MC9S08Rx HCS08RD/RG/RE8 HCS08RD/RG/RE16 HCS08RD/RG/RE32 HCS08RD/RG/RE60	335	16MHz XTAL	No	No	Hardware	512	64
HCS08JM32 HCS08JM60	6000	12MHz external clock	No	No	USB 2.0	512	64
MCF51JM64 MCF51JM128	1108	S08 MCGV3	No	No	Hardware	1024	128
MCF51QE32 MCF51QE64 MCF51QE128	1104	S08 ICSV3	No	No	Hardware	1024	128
MCF51CN64 MCF51CN128	1132	MCG	No	No	Hardware	1024	128

Table 2. Target implementation comparison (continued)

MCU Family	FLASH Memory Use (in Bytes)	Clock Source	ROM Routines Usage	Calibration Conducted	SCI	FLASH Erase Page Size (in Bytes)	FLASH Program Page Size (in Bytes)
MCF51AC128 MCF51AC256	1116	MCG	No	No	Hardware	1024	128
MCF51AG96 MCF51AG128	1120	ICS	No	No	Hardware	1024	128
MCF51EM128 MCF51EM256	1284	ICS	No	No	Hardware	1024	128
MCF51JM64 MCF51JM128	1116	MCG	No	No	Hardware	1024	128
MCF51JM64 MCF51JM128	8000	12MHz external clock	No	No	USB 2.0	1024	128
K10N1M0 K10N512 K10N256 K10N128 K10N64	32768 16384 8192 4096 2048	MCG	No	No	Hardware	2048	128
K20N512 K20N256 K20N128 K20N64 K20N32	16384 8192 4096 2048 1024	MCG	No	No	Hardware	2048	128
K30N512 K30N256	16384 8192	MCG	No	No	Hardware	2048	128
K40N512 K40N256 K40N128	16384 8192 4096	MCG	No	No	Hardware	2048	128
K50N512 K50N256	16384 8192	MCG	No	No	Hardware	2048	128
K60N1024 K60N512	32768 16384	MCG	No	No	Hardware	2048	128
K70N1M	32768	MCG	No	No	Hardware	2048	128
K22N1M0	32768	MCG	No	No	Hardware	2048	128
KL05Z32	2048	MCG	No	No	Hardware	1024	128
KL25Z128	4096	MCG	No	No	Hardware	1024	128
KM34Z128	4096	MCG	No	No	Hardware	1024	128

8.1 MC68HC908KX

The M68HC908KX Family has an Internal Clock Generator (ICG) module. This allows an effective implementation of the bootloader without a crystal.

The on-chip FLASH programming routines simplify the bootloader and improve memory usage. The communication between the MCU and PC uses a Standard Serial Channel (SCI).

The following flowchart shows the basic principle of the bootloading algorithm:

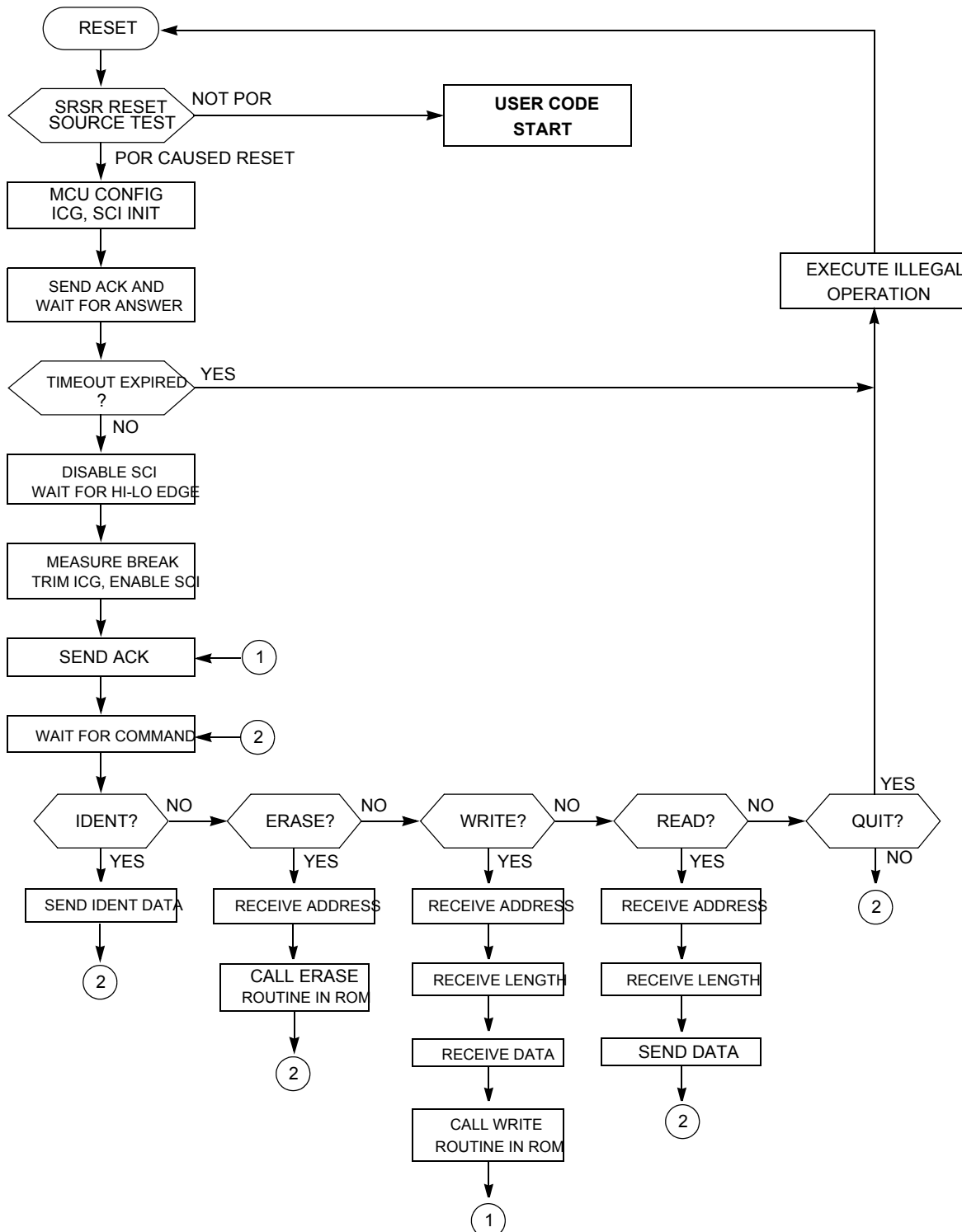

Figure 26. MC68HC908KX bootloader flowchart

8.1.1 Internal Clock Generator (ICG) — initialization

The ICG is simple to initialize because the ICG is active and the clock monitor is disabled after reset. The only action required is the modification of ICG multiply register. Then, the ICGS flag (bit 2) of the ICG control register indicates whether the ICG is stable after the frequency change.

```
ICGMRINIT      EQU      $20

                MOV      #ICGMRINIT,ICGMR      ; set 9.8304MHz BUS clock
LOOP:          BRCLR   2,ICGCR,LOOP           ; wait until ICG stable
```

8.1.2 Internal Clock Generator — trimming

Even though the trimming routine is in ROM, a small bug renders this code unusable; therefore, the source code has been taken and inserted in the bootloader code.

Although AN1831/D provides the procedure for calculating the trim factor from the measured CPU speed, the code itself omits the final doubling of the number of cycles.

```
* FOLLOWING LOOP IS EXECUTED UNTIL THE END OF THE BREAK SIGNAL. THE BREAK
* SIGNAL LASTS 10 BIT TIMES. IF COMMUNICATING AT f OP /256 BPS, THEN 10 BIT
* TIMES IS 2560 CYCLES. EACH TIME THROUGH THE LOOP IS 10 CYCLES, SO WE
* EXPECT TO EXECUTE THE LOOP 256 TIMES IF THE KX8 IS IN SYNC SERIALY WITH
* THE HOST. IF WE STAY IN THE LOOP FOR > 256 LOOP CYCLES, THEN THE KX8
* MUST BE RUNNING FASTER THAN EXPECTED, AND NEEDS TO BE SLOWED DOWN. IF WE
* STAY IN THE LOOP FOR < 256 LOOP CYCLES THEN THE KX8 MUST BE RUNNING SLOWER
* THAN EXPECTED AND NEEDS TO BE SPEEDED UP. THE AMOUNT THAT WE CHANGE THE
* CPU SPEED IS EQUAL TO THE NUMBER OF LOOP CYCLES OVER OR UNDER 256. SO IF
* WE GO THROUGH THE LOOP 240 TIMES, THEN WE ARE RUNNING
* (256-240)/256 = 6.25% FAST. EACH INCREMENTAL CHANGE WE MAKE TO THE TRIM REGISTER
* (ICGTR) WILL MAKE A 0.195% CHANGE TO THE INTERNAL CLOCK. THAT IS, INCREMENTING
* THE REGISTER BY ONE OVER THE DEFAULT VALUE OF $80 STORED THERE WILL
* DECREASE THE INTERNAL CLOCK BY 0.195%, AND VICE VERSA.
* NOW EACH EXECUTION OF THE LOOP OVER OR UNDER WHAT IS EXPECTED (256 TIMES)
* REPRESENTS AN ERROR OF 1/256 = .391% ERROR. SO WE'LL NEED TO DOUBLE THE
* NUMBER OF LOOP CYCLES AND USE THIS NUMBER TO CORRECT THE TRIM REGISTER.
* OUR PRECISION FOR TRIMMING IS THEREFORE 0.391%.
```

The actual code adds an ASLA instruction which doubles the trim factor before the actual write to the ICG trim register.

```
ICGTRIM:
    CLRX
    CLRH

MONPTB4:
    BRSET    4,PTB,MONPTB4    ;WAIT FOR BREAK SIGNAL TO START
CHKPTB4:
    BRSET    4,PTB,BRKDONE    ; (5) GET OUT OF LOOP IF BREAK IS OVER
    AIX      #1                ; (2) INCREMENT THE COUNTER
    BRA      CHKPTB4          ; (3) GO BACK AND CHECK SIGNAL AGAIN
BRKDONE:
    PSHH
    PULA                    ;PUT HIGH BYTE IN ACC AND WORK WITH A:X
    TSTA                    ;IF MSB OF LOOP CYCLES = 0, THEN BREAK TAKES TOO
```

```

TXA                ;FEW CYCLES THAN EXPECTED, SO TRIM BY SPEEDING
BEQ                ;UP f OP .
FAST:  CMP         #$40          ;SEE IF BREAK IS WITHIN TOLERANCE
      BGE         OOR           ;DON'T TRIM IF OUT OF RANGE
      ASLA        ;multiply by two to get right range
      ADD         #$80          ;BREAK LONGER THAN EXPECTED, SO SLOW DOWN f OP
      BRA         ICGDONE
SLOW:  CMP         #$C0          ;SEE IF BREAK IS WITHIN TOLERANCE
      BLT         OOR           ;DON'T TRIM IF OUT OF RANGE
      ASLA        ;multiply by two to get right range
      SUB         #$80
ICGDONE:
      STA         ICGTR
OOR:
      RTS

```

The complete explanation of the trimming procedure can be found in AN1831/D. See [References](#).

8.2 MC68HC908JK/JL

MC68HC908JK/JL MCUs are among the least expensive in the M68HC08 Family, and they have no hardware SCI. Therefore, a software SCI must be implemented. This allows the unrestricted selection of which pins are used for serial communication (the provisions are made in the code so an IRQ pin can also be used as an input serial line).

The MC68HC908JK/JL Family has a RC version (an RC oscillator is used instead of a crystal). The bootloader's calibration compensates for any speed variation. If the desired clock frequency is outside the specified range covered by the calibration system, the code must be modified.

The MC68HC908JK/JL Family has on-chip FLASH programming routines. Using FLASH programming saves memory.

The main program flowchart ([Figure 27](#)) is very similar to the previous case. The following figure represents the MC68HC908JK/JL Bootloader flowchart:

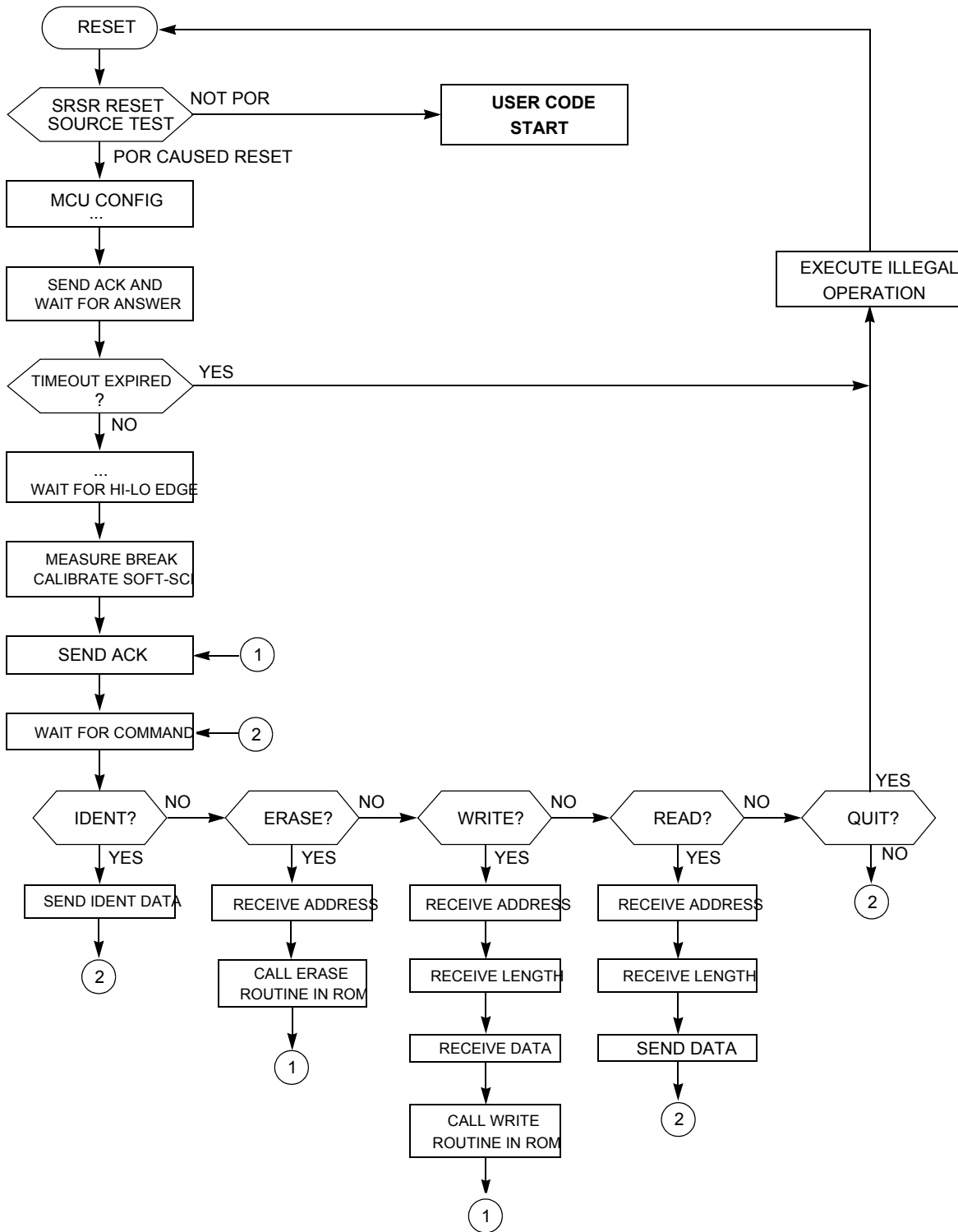

Figure 27. MC68HC908JK/JL bootloader

8.2.1 Software-SCI transmit char routine

A detailed description of the software-SCI transmit and receive subroutines is provided in this section. They both are based on a 16-bit timer and the output-compare event is polled in the background loop.

The following figure represents the software-SCI transmit char routine flowchart:

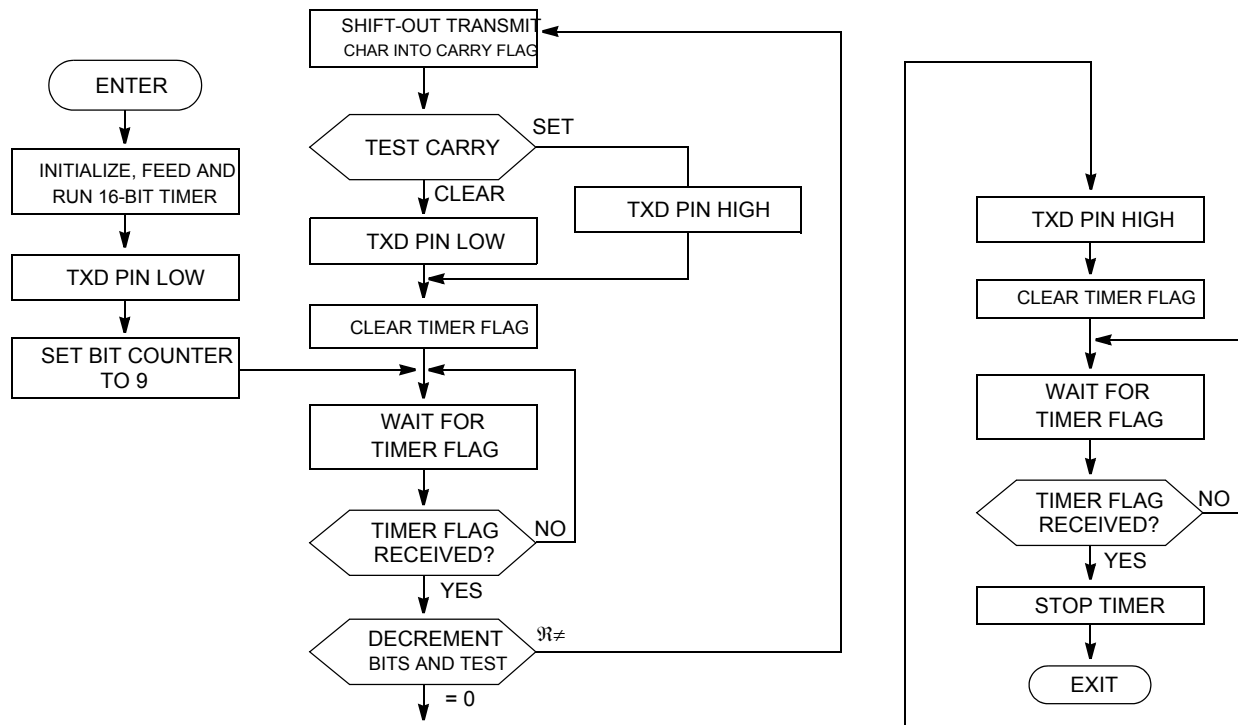

Figure 28. Software-SCI transmit char routine

The two routines' source code is shown in Figure 29. Other than a few counters, a 16-bit `ONEBIT` variable is used. It contains the actual length of 1 bit at the current communication speed in 16-bit timer clock cycles. This variable is initialized during the calibration phase ([Slave frequency calibration](#)).

The following figure represents the source code of software-SCI transmit char routine:

MCU slave software

```
;*****
SCITX:
    PSHH
    PSHX

    BCLR    7,TSC           ; and clear TOF
    LDHX   ONEBIT
    STHX   TMOD
    BSET   4,TSC           ; clear timer
    BCLR   5,TSC           ; run timer

    TXDCLR

    MOV    #9,BITS        ; number of bits + 1
    BRA   SCITX1          ; jump to loop

SCITX2:
    LSRA                   ; shift out lowest bit
    BCC   DATALOW

    TXDSET
    SKIP2                   ; skip next two bytes
DATALOW:
    TXDCLR

    BCLR   7,TSC           ; and clear TOF
SCITX1: BRCLR  7,TSC,SCITX1 ; wait for TOF

    DBNZ  BITS,SCITX2     ; and loop for next bit

SCISTOP:
    TXDSET

    BCLR   7,TSC           ; and clear TOF
SCITX3: BRCLR  7,TSC,SCITX3 ; wait for TOF
EPILOG:
    BSET   5,TSC           ; stop timer

    PULX
    PULH
    RTS
```

Figure 29. Software-SCI transmit char routine source code

8.2.2 Software-SCI receive char routine

The software-SCI receive char routine is similar to software-SCI transmit. When the 16-bit output-compare event is polled, the value of the receive pin is scanned. No provisions are made for stop-bit checking, framing check, noise detection, and others, mainly because of memory restrictions. The following figure shows the software-SCI receive routine flowchart, and the source code is provided in [Figure 31](#).

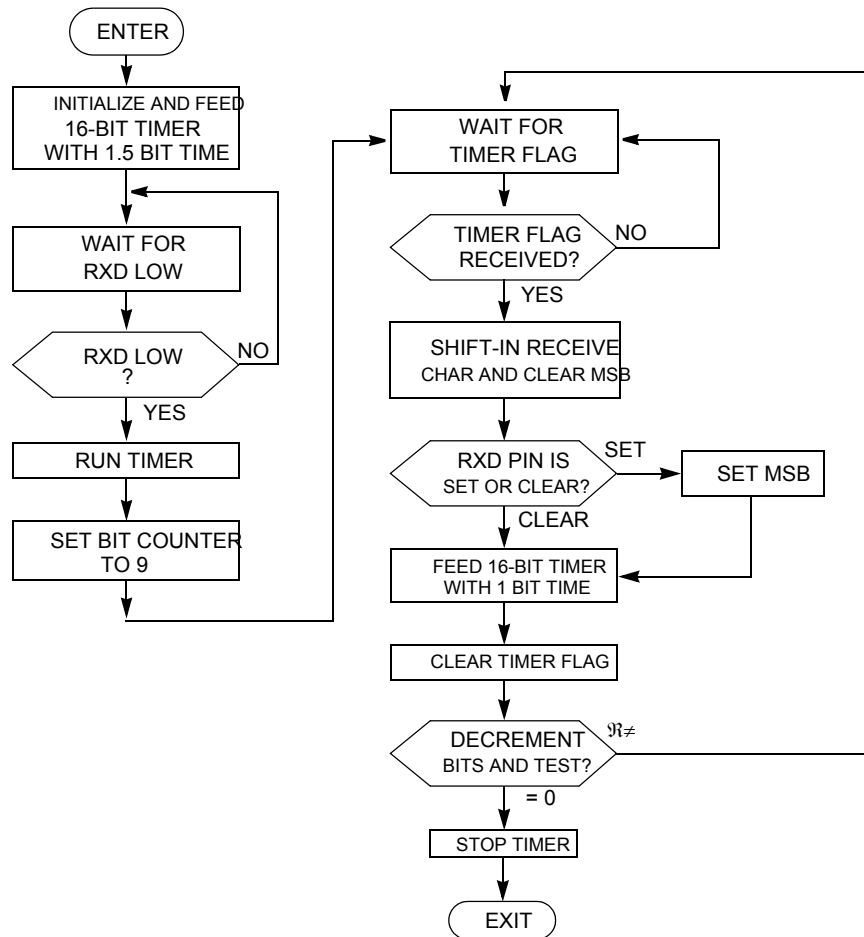

Figure 30. Software-SCI receive char routine

MCU slave software

```
*****  
SCIRX:  
    BRRXDLO SCIRX          ; loop until RXD high (idle)  
  
SCIRXNOEDGE:  
    PSHH  
    PSHX  
    BCLR    7,TSC          ; and clear TOF  
  
    LDX    ONEBIT  
    LDA    ONEBIT+1  
    LSRX  
    RORA  
    STX    TMODH  
    STA    TMODL  
  
    BSET    4,TSC          ; clear timer  
  
SCIRX1:  
    BRRXDHI SCIRX1        ; loop until RXD low (wait for start bit)  
  
    BCLR    5,TSC          ; run timer  
    MOV     #9,BITS        ; number of bits + 1  
  
SCIRX2: BRCLR    7,TSC,SCIRX2 ; wait for TOF  
  
    LSRA          ; shift data right (highest bit cleared)  
    BRRXDLO RXDLOW    ; skip if RXD low  
    ORA    #$80      ; set highest bit if RXD high  
  
RXDLOW: LDHX    ONEBIT  
    STHX    TMOD  
  
    BCLR    7,TSC          ; and clear TOF  
    DBNZ   BITS,SCIRX2    ; and loop for next bit  
  
    BRA    EPILOG
```

Figure 31. Software-SCI receive char routine source code

8.2.3 Macros

Several macros are defined across the two code listings. They improve the readability and memory consumption (Figure 32). The following figure represents the source code of software-SCI macros:

```

SKIP1          MACRO
                  DC.B    $21          ; BRANCH NEVER (saves memory)
                  ENDM

SKIP2          MACRO
                  DC.B    $65          ; CPHX (saves memory)
                  ENDM

BRRXDLO        MACRO

    IFNE    RXDISIRQ
    IFNE    SCIRXINV
        BIH    \1          ; branch if RXD low
    ELSE
        BIL    \1          ; branch if RXD low
    ENDIF
    ELSE    ; RXD uses normal I/O pin
    IFNE    SCIRXINV
        BRSET  RXDPIN,RXDPORT,\1    ; branch if RXD low
    ELSE
        BRCLR  RXDPIN,RXDPORT,\1    ; branch if RXD low
    ENDIF
    ENDIF

    ENDM

BRRXDHI        MACRO

    IFNE    RXDISIRQ
    IFNE    SCIRXINV
        BIL    \1          ; branch if RXD hi
    ELSE
        BIH    \1          ; branch if RXD hi
    ENDIF
    ELSE    ; RXD uses normal I/O pin
    IFNE    SCIRXINV
        BRCLR  RXDPIN,RXDPORT,\1    ; branch if RXD hi
    ELSE
        BRSET  RXDPIN,RXDPORT,\1    ; branch if RXD hi
    ENDIF
    ENDIF

    ENDM

TXDCLR         MACRO

    IFNE    SCITXINV
        BSET  TXDPIN,TXDPORT ; clr bit
    ELSE
        BCLR  TXDPIN,TXDPORT ; clr bit
    ENDIF

    ENDM

TXDSET         MACRO

    IFNE    SCITXINV
        BCLR  TXDPIN,TXDPORT ; set bit
    ELSE
        BSET  TXDPIN,TXDPORT ; set bit
    ENDIF

    ENDM

```

Figure 32. Software-SCI macros source code

8.3 MC68HC908GP

On-chip FLASH programming routines are not available in MC68HC908GP MCU. Therefore, all FLASH programming must be done by the bootloader, as demonstrated in this section.

MC68HC908GP MCUs are primarily targeted for use with a low-cost 32.768 kHz crystal. Because the frequency of the crystal is known, no calibration is performed, which saves MCU memory. Therefore, this MCU uses the [Known MCU communication speed](#) method.

The following figure is a flowchart of MC68HC908GP bootloader process:

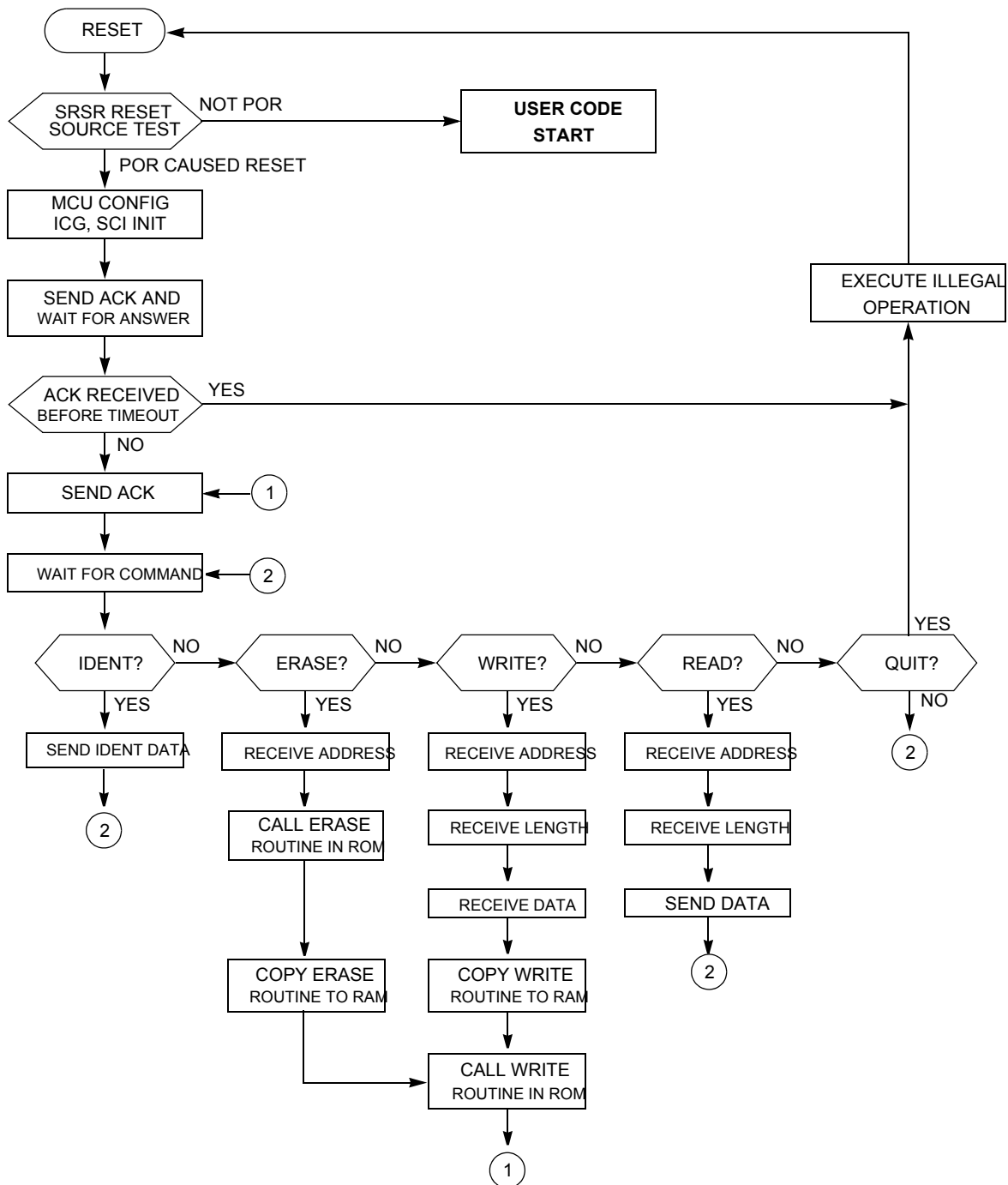

Figure 33. MC68HC908GP bootloader flowchart

8.3.1 FLASH programming routines

The main code is similar to the previous implementation with the calibration phase omitted. The FLASH programming by the bootloader is shown in Figure 34. Three main subroutines are defined as follows:

- CPY_PRG — copies the selected routine into RAM

MCU slave software

- ERASE_ALG — whole FLASH erase routine
- WR_ALG — whole WRITE erase routine

Because the flow is straightforward, no flowchart is provided. Basically, the sequence of events is executed according to FLASH erasing/programming specifications.

```
;*****
CPY_PRG:
    TSX
    STHX    STACK        ; copy stack for later re-call

    LDHX    SOURCE        ; LOAD WRITE ALGORITHM TO RAM
    TXS
    LDHX    #PRG
CPY_PRG_L1:
    PULA
    STA     X
    AIX    #1
    DBNZ   STAT,CPY_PRG_L1

    LDHX    STACK
    TXS
    RTS
;*****
ERASE_ALG:

    LDA    #%00000010
    STA    FLCR        ; ERASE bit on
    LDA    FLBPR        ; dummy read FLBPR

    LDHX    ADRS        ; write anything
    STA    X            ; to desired range
    D_US   #T10US      ; wait 10us

    LDA    #%00001010
    STA    FLCR        ; set HVEN, keep ERASE
    D_MS   #T1MS       ; wait 1ms

    LDA    #%00001000
    STA    FLCR        ; keep HVEN, ERASE off
    D_US   #T5US       ; wait 5us

    CLRA
    STA    FLCR        ; HVEN off
    D_US   #T1US       ; wait 1us

    JMP    SUCC        ; finish with ACK
ERASE_ALG_END:
;*****
WR_ALG:

    LDA    #%00000001
    STA    FLCR        ; PGM bit on
    LDA    FLBPR        ; dummy read FLBPR

    LDHX    ADRS        ; prepare addresses
    STA    X            ; and write to desired range
    D_US   #T10US      ; wait 10us
```

```

        LDA    #%00001001
        STA    FLCR           ; set HVEN, keep PGM
        D_US   #T5US         ; wait 5us

        LDHX   #DAT           ; prepare addresses
        TXS
        LDHX   ADRS
        MOV    LEN,POM

WR_ALG_L1:
        PULA
        STA    X
        AIX    #1
        D_US   #T30US        ; wait 30us
        DBNZ   POM,WR_ALG_L1 ; copy desired block of data

        LDA    #%00001000
        STA    FLCR           ; keep HVEN, PGM off
        D_US   #T5US         ; wait 5us

        CLRA
        STA    FLCR           ; HVEN off
        D_US   #T1US         ; wait 1us

        JMP    RETWR         ; finish with ACK (& restore STACK before)
WR_ALG_END:
END

```

Figure 34. FLASH programming routines source code

For improved readability, two timing macros (D_US and D_MS) are used in the code (Figure 35).

```

;*****
D_MS:   MACRO
        LDA    \1           ; [2] ||
\@L2:   CLRX           ; [1] ||
\@L1:   NOP           ; [1] |
        DBNZX  \@L1      ; [3] |    256*4 = 1024T
        DBNZA  \@L2      ; [3] || (1024+4)*(arg-1) + 2 T
        ENDM

D_US:   MACRO
        LDA    \1           ; [2]
\@L1:   NOP           ; [1]
        DBNZA  \@L1      ; [3] 4*(arg-1) + 2 T
        ENDM

```

Figure 35. FLASH programming macros source code

8.4 MC68HC908GR

MC68HC908GR MCUs are smaller members of the MC68HC908GP Family, equipped with ROM memory with on-chip FLASH programming routines available in the user mode.

MC68HC908GP and MC68HC908GR MCUs are primarily targeted for use with a low-cost 32.768 kHz crystal. Because the frequency of the crystal is known, no calibration is performed, which saves MCU memory. Therefore, these MCUs use the [Known MCU communication speed](#) method.

8.5 MC68HC908MR

MC68HC908MR MCUs are motor-control oriented members of the M68HC08 Family. The MC68HC908MR MCUs have no on-chip FLASH programming routines available. Therefore, all FLASH programming must be done by the bootloader.

The MC68HC908MR Family has a PLL (phase-locked loop) circuit that can multiply the crystal frequency. Typically, a 4-MHz XTAL is used as the reference frequency. This implementation demonstrates how the PLL circuit is initialized for 8 times the crystal frequency. Therefore, the source PLL frequency is 32 MHz, and the bus frequency is 8 MHz.

Because the frequency of the crystal is known, no calibration is performed, which saves MCU memory. Therefore, these MCUs use the [Known MCU communication speed](#) method.

8.6 MC68HC908EY

The code for MC68HC908GT and MC68HC908EY MCUs is similar to [MC68HC908KX](#) code, except for the memory maps and ROM routine locations. One minor difference is that the MC68HC908GT Family cannot use the CGMXCLK clock as the SCI module source. Therefore, the bus clock is the only possible clock source.

8.7 MC68HC908QT/QY

MC68HC908QT/QY MCUs are the smallest members of the M68HC08 Family. They have a simple ICG module (running on fixed frequency 12.8 MHz \pm 25%). ROM routines are available.

There are several spare FLASH locations (mainly among unused interrupt vectors) also used for storing the bootloader code.

8.7.1 SCI Application Program Interface (SCI-API)

Software SCI communication is implemented on MC68HC908QT/QY, MC68HC908JK/JL, and MC68HC908LB MCUs to reduce cost and enable the user code to call the SCI send and receive routines (with certain limitations). The bootloader code now implements SCI-API, which is the defined way to call the SCI send and receive routines.

The detailed information, implementation notes, and limitations are provided in the `sci.h` file (of the QTQY folder). This file is the only resource that must be included in the user C code. The calling convention and overall usage is described in this file, too. The main limiting factor for most applications will be that the SCI receive routine is a blocking one. This means that routines will not return until an SCI character is received. The 16-bit timer registers are also manipulated. Some applications will use this code without problems.

8.7.2 Single-Wire communication

Because of the small number of pins on MC68HC908QT devices, the single-wire SCI version has been developed to keep the number of pins occupied by communication to a minimum. Figure 36 illustrates an example single-wire RS-232 interface. The single-wire option has been ported to MC68HC908JK/JL and MC68HC908LB bootloader because they also use a software SCI.

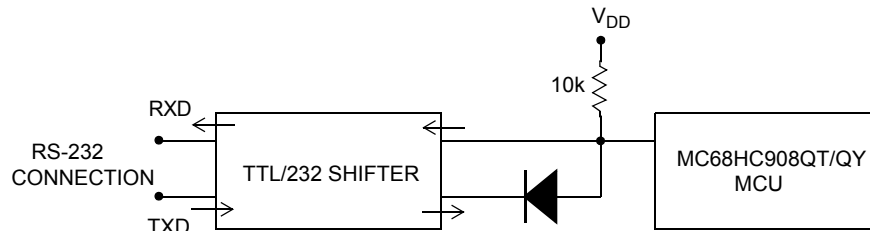

Figure 36. Example single-wire schematic

The bootloader's master side must be informed that the single-wire communication is used. This can be done by calling the `hc08sprg.exe` software. Use the following extended calling convention:

```
hc08sprg.exe 1:S filename.s19
```

where, 1 specifies which COM port is used for communication and S stands for single-wire.

Original (old) format: `hc08sprg.exe 1 filename.s19`

Now defaults to: `hc08sprg.exe 1:D filename.s19`

where, D stands for dual-wire mode. The bootloader master can also detect the presence of a single-wire interface if called:

```
hc08sprg.exe 1:? filename.s19
```

The detection is only possible if the serial interface (mainly the level shifter) is powered up and working before the bootloading process starts. Because this is not usually the case, always specify the bootloading mode by including either “:S” or “:D” in the parameter.

8.8 MC68HC908LJ

MC68HC908LJ MCUs are members of the M68HC08 Family used to drive LCD displays.

MC68HC908LJ MCUs have the ROM on-chip FLASH programming routines available. The calling convention is slightly different from other M68HC08s (see MC68HC908LJ data sheet, monitor ROM section).

MC68HC908LJ MCUs are primarily targeted to use with a low-cost 32.768 kHz crystal. Because the frequency of the crystal is known, no calibration is performed, which saves MCU memory. Therefore, these MCUs use the [Known MCU communication speed](#) method.

8.9 MC68HC908AP

MC68HC908AP devices are members of the M68HC08 Family that have two SCIs (the SCI channel must be selected at compile time). MC68HC908AP MCUs have ROM on-chip FLASH programming routines available. The calling convention is slightly different from other M68HC08s (same as MC68HC908LJ devices).

Because of the internal oscillator's simplicity, it does not have the accuracy and stability of the RC oscillator or the XTAL oscillator. Therefore, the internal oscillator is not suitable if an accurate bus clock is required and it should not be used as the bus clock source.

A low-cost 32.768 kHz crystal was selected as default source clock for bootloader and user application. Because the frequency of the crystal is known, no calibration is performed, which saves MCU memory. Therefore, these MCUs use the [Known MCU communication speed](#) method.

8.10 MC68HC908AB/AS/AZ

MC68HC908AB/AS/AZ devices are members of the M68HC08 Family that also have EEPROM memory. This code also demonstrates the way to program these EEPROM cells using AUTO (automatic clear of EEPGM) mode.

Since the memory map is not continuous, FC protocol version 3 needs to be used (it allows the "holes" in the memory map, that is, several separate memory blocks).

8.11 MC9S08GB/GT

MC9S08GB/GT devices are the first members of the HCS08 Family. Because of different hardware features and FLASH memory allocation, another version of the protocol was required. The protocol is detected automatically by the latest `hc08sprg.exe` PC Bootloader software and becomes invisible to the user.

MC9S08GB/GT MCUs have two SCIs (the SCI channel must be selected at compile time).

These MCUs have no on-chip FLASH programming routines. Therefore, the bootloader must do all FLASH programming, and this implementation demonstrates this (it has been entirely adopted from HCS08 Family Reference Manual Volume 1 (Freescale Semiconductor order number HCS08RMv1/D; see [References](#)).

8.12 MC68HC908JW

The HC908JW family has a built-in USB 2.0 Full Speed module. This allows a direct connection via a true USB interface with the PC. As described in [AN3153: Using the Full-Speed USB Module on the MCHC908JW32](#) application note, the emulation of the serial COM port can be easily designed. This way, a fully compatible bootloader (written in C) for the JW32 family has been designed. Once the bootloader is programmed into the JW32 device, the user code can be reprogrammed anytime using a native USB connection (serial COM port emulation in Windows).

The installation and usage details are documented in [ZSTARRM: Wireless Sensing Triple Axis Reference design](#), chapter 5.5 and 6.1.2, out of which the JW32 USB bootloader has been derived. The PC drivers

required for USB are also inside the JW32 folder of the AN2295SW software package. Alternatively, the latest on-line version of the PC drivers is available on the ZSTAR summary page ([RD3152MMA7260Q](http://www.freescale.com/rd3152mma7260q)).

NOTE

Although serial COM emulation on the JW32 has been successfully tested in Linux, a Linux port of hc08sprg executable of the AN2295 bootloader master was not tested together with the JW32 bootloader USB implementation.

8.13 HCS08JM and MCF51JM

The MCF51JM family has a built-in USB 2.0 Full Speed module. This allows a direct connection through a true USB interface with the PC. As described in AN3492: USB and Using the CMX USB Stack application note, the emulation of the serial COM port can be easily designed. This way, a fully compatible bootloader (written in C) for the HCS08JM and MCF51JM families has been designed. This USB driver is used for communication with the PC Communication Device Class (CDC). The basis of this communication is creating a Virtual Serial Port on the PC side. This feature allows using master bootloader software without any modification of the source code. For more information, refer AN3492 : USB and Using the CMX USB Stack.

9 PC bootloader master software

This section provides a detailed description of the bootloader host computer master software, which is downloadable as a zip file from the Freescale Semiconductor website, [freescale.com](http://www.freescale.com). All code is written in C language and is compatible with Linux and Win32 platforms.

The bootloader specifications dictate that, as much as possible, intelligence is executed in the host computer instead of MCU, minimizing MCU memory consumption. Only primitive functions are implemented in the MCU.

In this section, portions of the master bootloader code will be described in more detail. All actions required for reprogramming the M68HC(S)08, Coldfire V1, and Kinetis devices are described in the slave implementation and protocol sections of this document. The specific master characteristics are emphasized.

The host computer master software design is straightforward and is a sequence of several steps:

- Opening the serial port
- Opening the source S19 file
- Waiting for the reset of the MCU
- Calibrating the MCU
- Reading MCU information
- Remapping MCU interrupt vectors
- Checking if the source S19 data fits into the physical MCU memory
- Erasing and programming MCU
- Cleaning up, exiting program

The following figure displays the bootloader master flowchart:

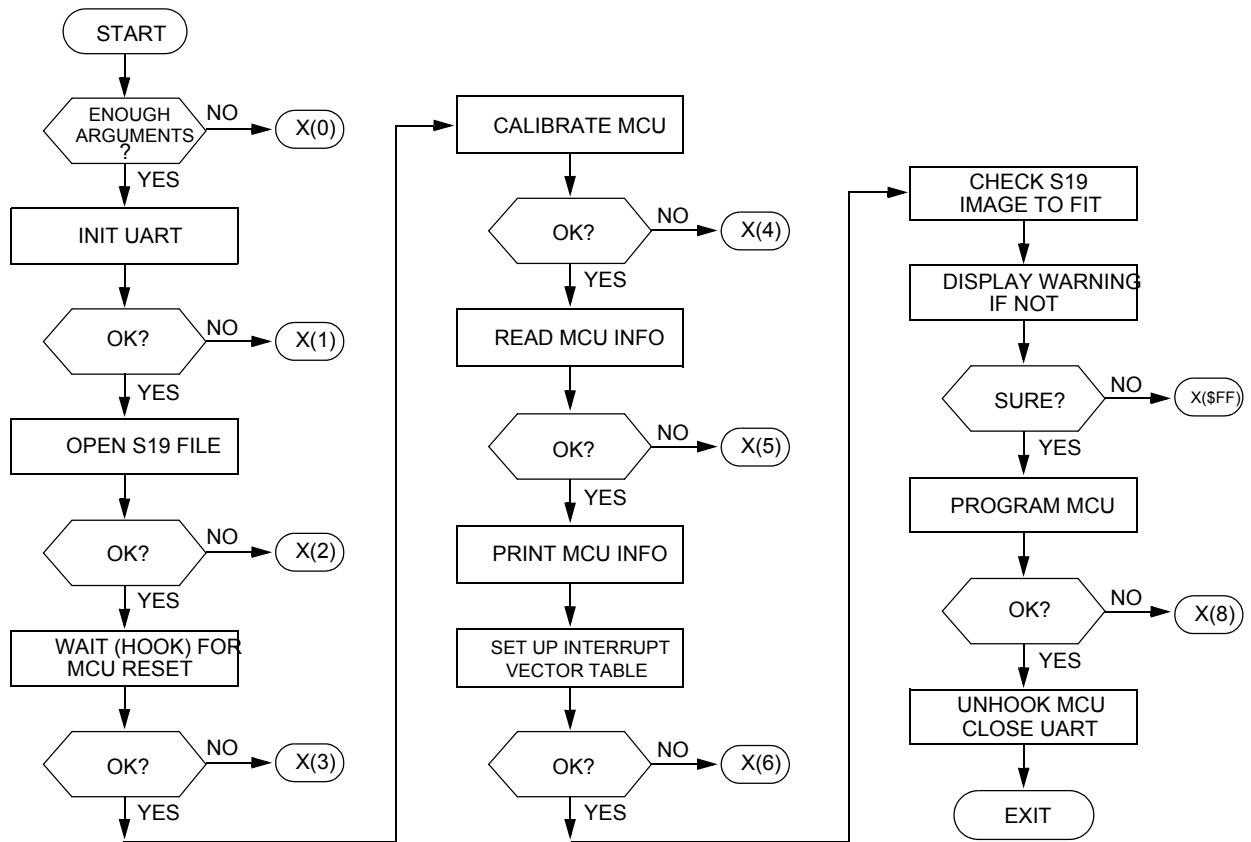

NOTE: X(2) MEANS EXIT WITH EXIT CODE

Figure 37. Bootloader master flowchart

9.1 File structure

The following file structure setup is used in PC master software:

- [8-Bit and 32-Bit MCU image operations:](#)
 - s19.c
- [UART manipulations:](#)
 - serial.h
- seriallinux.c (serialw32.c)
 - [System platform dependent files:](#)
- sysdep.h
 - sysdeplinux.h
 - sysdepw32.h
- [Generic and main program files:](#)

- hc08sprg.h
- main.c
- [M68HC\(S\)08, ColdFire and Kinetis specific programming files:](#)
 - prog.c

9.2 8-Bit and 32-Bit MCU image operations

To perform the necessary operations with the code, the master software keeps a binary image of the memory. In addition, it stores the information about whether an actual byte is to be programmed into the MCU is stored. This can be achieved using the following structure:

```
typedef struct {
    BYTE d[0x10000];    // data
    BYTE f[0x10000];    // valid flag 0=empty; 1=usercode; 2=systemcode
} BOARD_MEM;
```

where, `image` is the actual variable defined as follows:

```
BOARD_MEM image;
```

After the source S19 files are read, this array contains the actual data to be programmed into the MCU irrespective of its original order in the S19 file. The function `int read_s19(char *fn)` defined in `s19.c` implements the S19 file opening, reading, and relocation from S19 hexadecimal format into this binary array.

9.2.1 Interrupt vector table relocation

After the ident information is read out by the MCU, the following operations within the image are performed:

- The code is scanned to determine if any interrupt vectors are present between the MCU interrupt vector table address and `0xFFFF` (the last existing physical address of the M68HC(S)08 MCU).
- If interrupt vectors are present, relocation of these vectors is done as described in [Interrupt vector table relocation](#). Then, the original address spaces in the interrupt vector table are marked as unused, thus, not being reprogrammed.

These operations are executed in the function `int setup_vect_tbl(void)` defined in `prog.c` file.

9.2.2 Checking memory boundaries

The last check performed before the code is actually programmed into the MCU is to determine if the code from the S19 file is in the correct memory locations (between the memory boundaries reported by the MCU in the ident table).

If any value outside the range of addresses between the start address of reprogrammable memory area and the end address of reprogrammable memory area is found, a warning is generated.

This check is done in `int check_image(void)` also defined in the `prog.c` file.

9.3 UART manipulations

In `seriallinux.c` or `serialw32.c`, depending on the platform used, the following UART manipulation functions are defined:

```
int init_uart(char* nm);
int close_uart(void);
int send_break10(void);
int flush_uart(int out, int in);
int wb(const void* data, unsigned len);
int rb(void* dest, unsigned len);
```

The pair `int init_uart(char* nm)` and `int close_uart(void)` manage opening (initialization) and closing of the specified UART port.

The pair `int wb(const void* data, unsigned len)` and `int rb(void* dest, unsigned len)` is used for writing and reading blocks of data into/out of UART.

Two additional functions are required for the bootloader to work: `int send_break10(void)` and `int flush_uart(int out, int in)`. The first sends a BREAK character to the UART, the second cleans up both directions (in/out) of the UART buffers.

9.4 System platform dependent files

The header file `sysdep.h` includes either `sysdeplinux.h` or `sysdepw32.h`, depending on the platform software being compiled. The platform-specific declarations are then used.

9.5 Generic and main program files

The header file `hc08sprg.h` contains the rest of the generic declarations needed to compile the application. The file `main.c` contains the main program and is shown at the beginning of this section (Figure 37).

9.6 M68HC(S)08, ColdFire and Kinetis specific programming files

The most important part of the PC Bootloader software is contained in the file `prog.c` implements most of the intelligence of the PC bootloader software as mentioned in previous sections.

Numerous routines are implemented in the `prog.c` file:

```
int hook_reset(void)
int could_be_ack(unsigned b)
int calibrate_speed(void)
int read_mcu_info(void)
int setup_vect_tbl(void)
int check_image()
int read_blk(unsigned adr, int len, BYTE *dest)
int erase_blk(unsigned a)
int prg_blk(unsigned a, int len)
int prg_area(unsigned start, unsigned end)
int prg_mem(void)
int erase_mem(unsigned all)
int verify_mem(int byS19_range)
int prg_only_mem(void)
int unhook(void)
```

```

void CRC_AddByte(unsigned short *pCrc, unsigned char data)
void CRC_AddWord(unsigned short *pCrc, unsigned short data)
void CRC_Add3Bytes(unsigned short *pCrc, unsigned long data)
void CRC_AddLong(unsigned short *pCrc, unsigned long data)
void CRC_AddByteArray(unsigned short *pCrc, unsigned char* data, int size)
void CRC_AddString(unsigned short *pCrc, unsigned char* str)
void CRC_ResetCRC(unsigned short *pCrc, unsigned short seed)
unsigned short CRC_GetCRC(unsigned short *pCrc)

```

9.6.1 Initial hook (waiting for MCU reset)

Immediately after all initializations are done in the PC, a loop starts to wait for communication from the MCU. The `int hook_reset(void)` routine implements all necessary steps to establish initial communication with the MCU.

9.6.2 Checking ACK

A routine `int could_be_ack(unsigned b)` checks if a received character fits the possible set of characters that can be received due to a communication speed mismatch (See [Unknown MCU communication speed](#)).

9.6.3 Speed calibration

A speed calibration loop, implemented in the `int calibrate_speed(void)` routine, follows the scenario described in [Slave frequency calibration](#). If no ACK is received from the MCU, another break character is sent.

9.6.4 MCU information reading

Immediately after the calibration is successfully completed, the PC requests the [Ident command](#), to which the MCU responds with information about itself. This is achieved in the `int read_mcu_info(void)` routine.

9.6.5 Image manipulations

The two functions, `int setup_vect_tbl(void)` and `int check_image()`, are described in [8-Bit and 32-Bit MCU image operations](#).

9.6.6 Block operations

Three main data exchange operations are performed:

- Erase block
- Read block
- Write (program) block

These basic operations are implemented in the functions:

```
int erase_blk(unsigned a)
```

```
int read_blk(unsigned adr, int len, BYTE *dest)
int prg_blk(unsigned a, int len)
```

The actual implementation is straightforward and follows the rules described in [Interpreting MCU commands](#).

9.6.7 Main programming loop

The core of the bootloader's programming capabilities is implemented in the function `int prg_area(unsigned start, unsigned end)`. The function of this routine is to read data from an image and split the data into appropriately sized blocks (minimum erase/write block sizes). Then the erase block and write block routines are called, in that order.

The routine also prints the progress information to the standard I/O (for example, block boundary addresses and progress indicator).

One additional auxiliary function, `int prg_mem(void)`, is included. It retrieves the lowest and highest memory addresses that must be programmed because those addresses are used for calling the `int prg_area(unsigned start, unsigned end)` function.

9.6.8 CRC calculation

The new version of bootloader protocol add option to secure serial communication protocol by CRC-CCITT check. So the PC source code contains a few basic primitive functions to support this possibility:

```
void CRC_AddByte(unsigned short *pCrc, unsigned char data)
void CRC_AddWord(unsigned short *pCrc, unsigned short data)
void CRC_Add3Bytes(unsigned short *pCrc, unsigned long data)
void CRC_AddLong(unsigned short *pCrc, unsigned long data)
void CRC_AddByteArray(unsigned short *pCrc, unsigned char* data, int size)
void CRC_AddString(unsigned short *pCrc, unsigned char* str)
void CRC_ResetCRC(unsigned short *pCrc, unsigned short seed)
unsigned short CRC_GetCRC(unsigned short *pCrc)
```

9.6.9 Final unhook

Function `int unhook(void)` sends out the [Quit command](#).

10 Master applications user guides

The bootloader binary code (S19 file) is loaded in the MCU like any other regular 8-bit MCU (using MON08 serial programmer or other, for HCS08 using BDM interface). Then the MCU is soldered, or socketed, in the application.

Using the bootloader preprogrammed into the MCU, the user can download the 8-bit MCU user application code via SCI interface using the bootloader utility.

10.1 Bootloading operation (command line version)

Open a command prompt in the Linux or Windows directory where the copy of `hc08sprg` executable and `S19` files are.

Assuming the serial board is connected to, for example, a second serial port (COM3 /dev/ttyS1, with speed sets to 115200 bd/s and short trim is used) and is not yet powered on, invoke the bootloader using following sequence: `hc08sprg.exe 3:D* 115200 k60_test.s19`

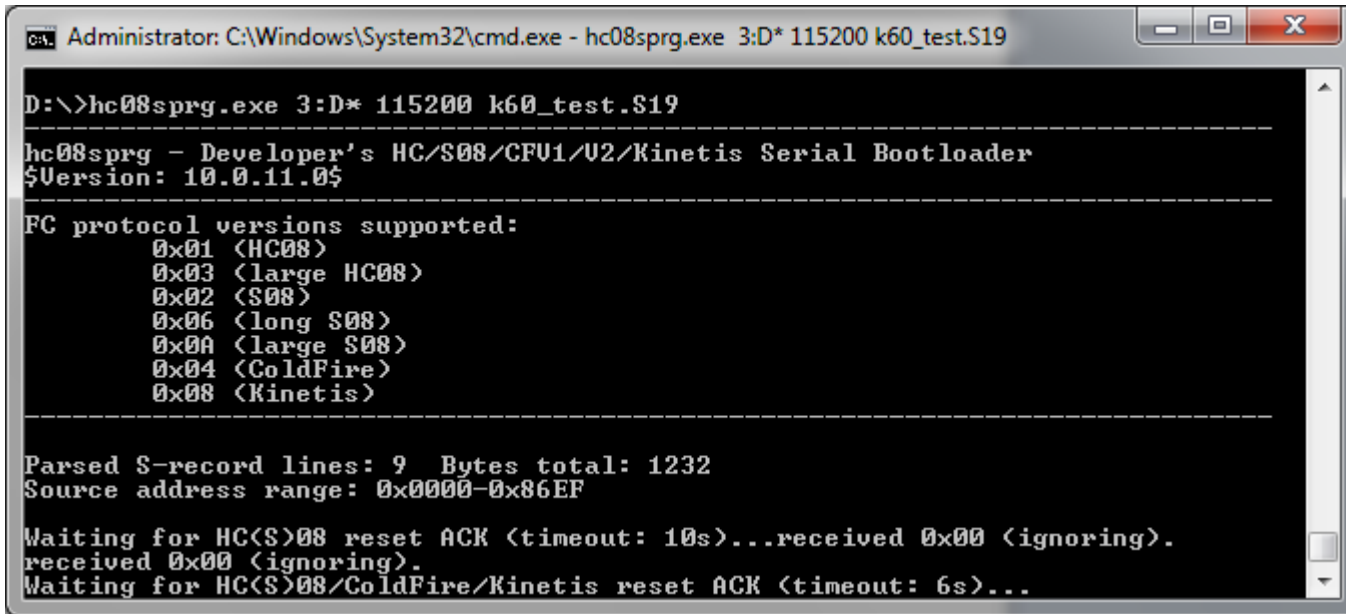

```
Administrator: C:\Windows\System32\cmd.exe - hc08sprg.exe 3:D* 115200 k60_test.S19
D:\>hc08sprg.exe 3:D* 115200 k60_test.S19
-----
hc08sprg - Developer's HC/S08/CFU1/U2/Kinetis Serial Bootloader
$Version: 10.0.11.0$
-----
FC protocol versions supported:
  0x01 <HC08>
  0x03 <large HC08>
  0x02 <S08>
  0x06 <long S08>
  0x0A <large S08>
  0x04 <ColdFire>
  0x08 <Kinetis>
-----
Parsed S-record lines: 9 Bytes total: 1232
Source address range: 0x0000-0x86EF
Waiting for HC(S)08 reset ACK (timeout: 10s)...received 0x00 <ignoring>.
received 0x00 <ignoring>.
Waiting for HC(S)08/ColdFire/Kinetis reset ACK (timeout: 6s)...
```

Figure 38. Bootloader invocation

The bootloader now expects the ACK command to be received from the MCU bootloader-enabled application. Then **turn the power on** for serial board and if all connections are OK, the MCU begins communication with the PC. The calibration procedure does not occur if the bootloader version with known communication speed is used followed by IDENT command. The information that is acquired from the MCU is then displayed on the screen (Figure 39).

```

Administrator: C:\Windows\System32\cmd.exe - hc08sprg.exe 1:D* 115200 k60_test.S19

D:\>hc08sprg.exe 1:D* 115200 k60_test.S19

hc08sprg - Developer's HC/S08/CFU1/U2/Kinetis Serial Bootloader
$Version: 10.0.11.05

-----
FC protocol versions supported:
  0x01 (HC08)
  0x03 (large HC08)
  0x02 (S08)
  0x06 (long S08)
  0x0A (large S08)
  0x04 (ColdFire)
  0x08 (Kinetis)
-----

Parsed S-record lines: 9  Bytes total: 1232
Source address range: 0x0000-0x86EF

Waiting for HC(S)08/ColdFire/Kinetis reset ACK (timeout: 8s)...received 0x00 (ignoring).
Waiting for HC(S)08/ColdFire/Kinetis reset ACK (timeout: 7s)...received 0xfc (good).
Calibration break pulse sent. Count: 3

Bootloader protocol version: 0x08 (Kinetis, read command supported,
Protocol secured: CRC-CCITT)
Bootloader version string: K60
System device ID: 0x14A [Kinetis K60] rev. 0
Kinetis Package: 144-pin .
Number of memory blocks: 1
Memory block #1: 0x00004000-0x0007FFFF
Erase block size: 2048 bytes
Write block size: 128 bytes
Original vector table: 0x00000000-0x000003FF
New vector table: 0x00004000-0x000043FF

Are you sure to program part? [y/N]:

```

Figure 39. First stage of bootloading

Confirm by pressing ‘y’ and bootloading (FLASH reprogramming) will continue. The user application will then start.

```

Administrator: C:\Windows\System32\cmd.exe
D:\>hc08sprg.exe 3:D* 115200 k60_test.S19
-----
hc08sprg - Developer's HC/S08/CFU1/U2/Kinetis Serial Bootloader
$Version: 10.0.11.0$
-----
FC protocol versions supported:
  0x01 (HC08)
  0x03 (large HC08)
  0x02 (S08)
  0x06 (long S08)
  0x0A (large S08)
  0x04 (ColdFire)
  0x08 (Kinetis)
-----
Parsed S-record lines: 9 Bytes total: 1232
Source address range: 0x0000-0x86EF
Waiting for HC(S)08/ColdFire/Kinetis reset ACK (timeout: 7s)...received 0x00 (ignoring).
received 0xfc (good).
Send Standard 0.
Calibration break pulse sent. Count: 1
Bootloader protocol version: 0x08 (Kinetis, read command supported, Protocol secured: CRC-CCITT)
Bootloader version string: K60
System device ID: 0x14A [Kinetis K60] rev. 0
Kinetis Package: 144-pin
Number of memory blocks: 1
Memory block #1: 0x00004000-0x0007FFFF
Erase block size: 2048 bytes
Write block size: 128 bytes
Original vector table: 0x00000000-0x000003FF
New vector table: 0x00004000-0x000043FF
Are you sure to program part? [y/N]: y
Memory is erased.
Memory programmed:          100%
Memory verified:            OK
D:\>

```

Figure 40. Bootloading completed

10.1.1 Memory boundary overlap example

If the user tries to bootload an application that will not fit in the actual MCU memory, a warning message is displayed. The user may decide to continue, but some memory locations may be programmed incorrectly (the user code is either out of available FLASH memory or it overlaps with the bootloader code).

```

Administrator: C:\Windows\System32\cmd.exe - hc08sprg.exe 3:D* 115200 wontFit.S19
D:\>hc08sprg.exe 3:D* 115200 wontFit.S19
-----
hc08sprg - Developer's HC/S08/CFU1/U2/Kinetis Serial Bootloader
$Version: 10.0.11.0$
-----
FC protocol versions supported:
  0x01 (HC08)
  0x03 (large HC08)
  0x02 (S08)
  0x06 (long S08)
  0x0A (large S08)
  0x04 (ColdFire)
  0x08 (Kinetis)
-----
Parsed S-record lines: 113 Bytes total: 3054
Source address range: 0x0000-0x0FE5

Waiting for HC(S)08 reset ACK (timeout: 10s)...received 0x00 (ignoring).
received 0xfc (good).
Send Standard 0.
Calibration break pulse sent. Count: 1

Bootloader protocol version: 0x08 (Kinetis, read command supported,
Protocol secured: CRC-CCITT)
Bootloader version string: K60
System device ID: 0x14A [Kinetis K60] rev. 0
Kinetis Package: 144-pin
Number of memory blocks: 1
Memory block #1: 0x00004000-0x0007FFFF
Erase block size: 2048 bytes
Write block size: 128 bytes
Original vector table: 0x00000000-0x000003FF
New vector table: 0x00004000-0x000043FF

WARNING! S19 image will not fit into available memory (at address 0x0000400)!
Are you sure to program part? [y/N]:

```

Figure 41. Memory boundary overlap example

10.2 Bootloading operation (windows version)

A version of the PC master application is also present (based on the same source codebase) in the Windows user friendly form. The application allows carrying out individual steps with the bootloader and also automatic steps as with the command line version.

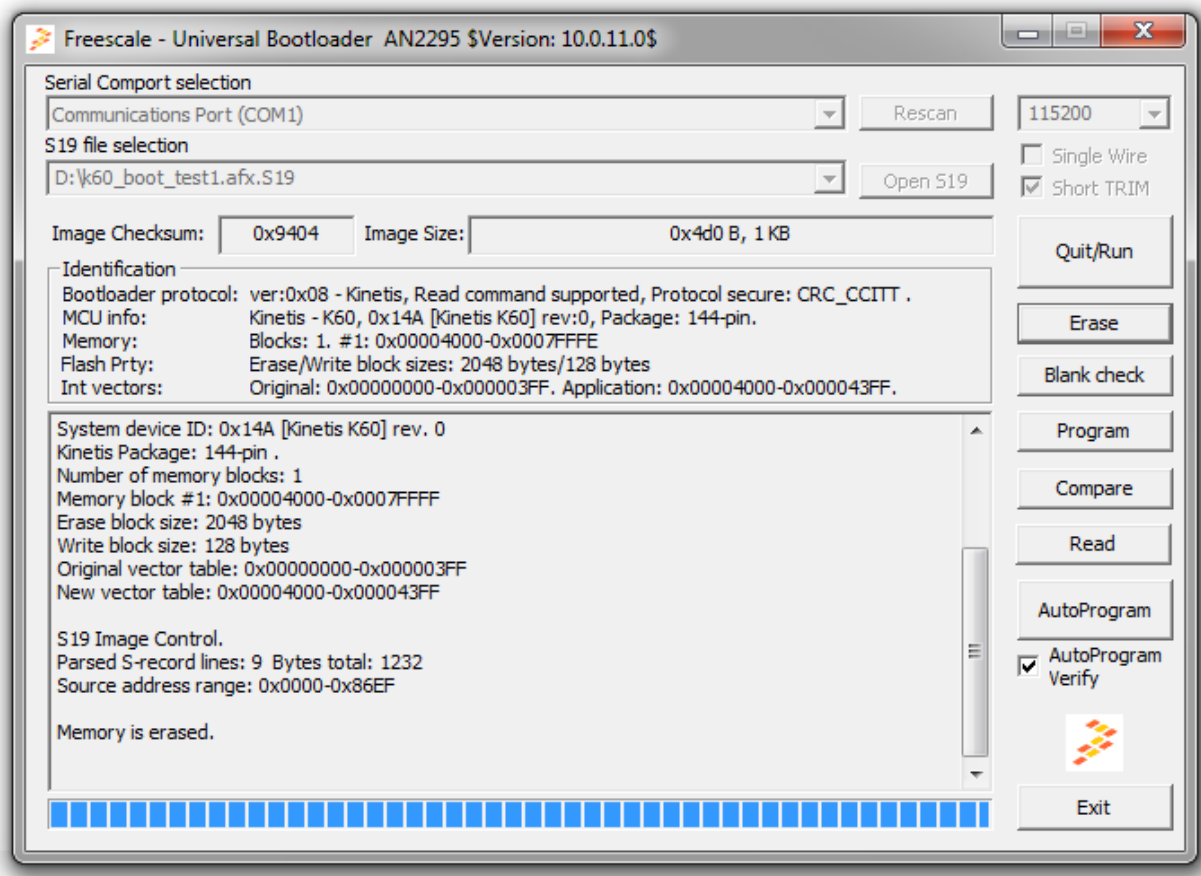

Figure 42. Windows based PC master application

10.2.1 How to use the Windows version of master application

10.2.1.1 Open the “win_hc08sprg.exe”

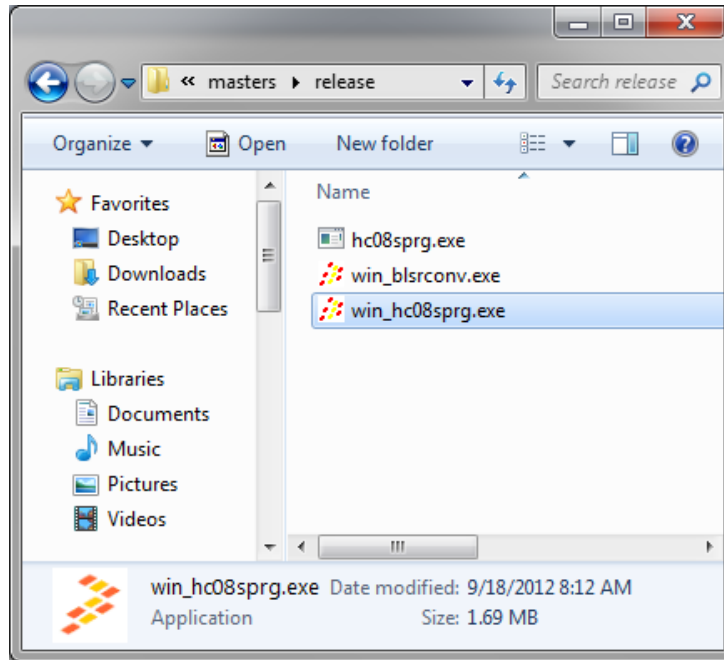

Figure 43. The PC master release folder

This is stored in release folder of PC master applications.

10.2.1.2 Setup the application for connection with target

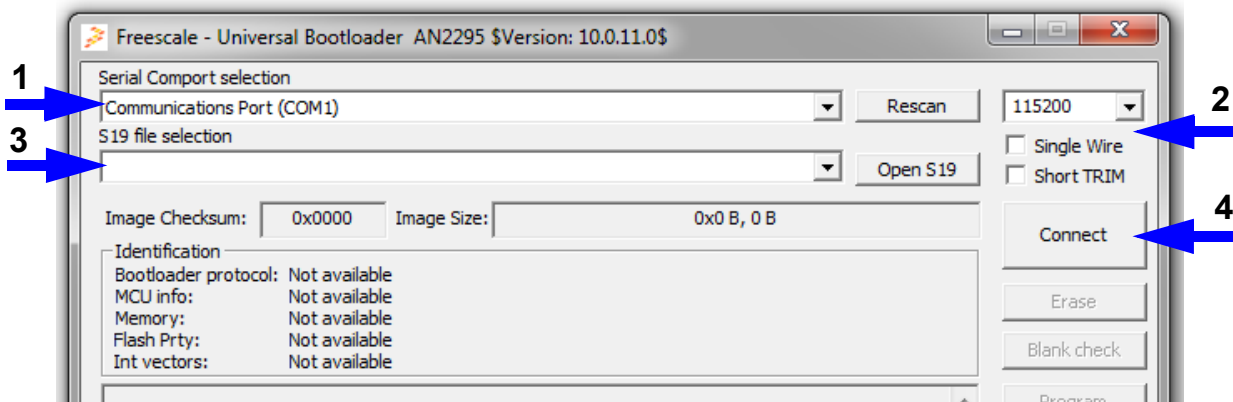

Figure 44. Setup the application for connection with target

1. Select the right Communication port. In case that the port is not in list, try to re scan communication ports in your PC by button “Rescan”.
2. Setup the communication option to meet the settings of target.
 - Communication speed - select the communication baud rate
 - Single Wire - check if the target is connected through the one wire connection

- Short TRIM - check if the target is configured to used short clock calibration (trim) pulse.
- 3. Select the S19 file - To add the new S19 file into list use the “Open S19” button, for reuse the any file that has been already opened just select it from the combo box.
- 4. Connect the target - hit the button “Connect” and run the target with bootloader startup options enabled

10.2.1.3 Using the Windows version of master application

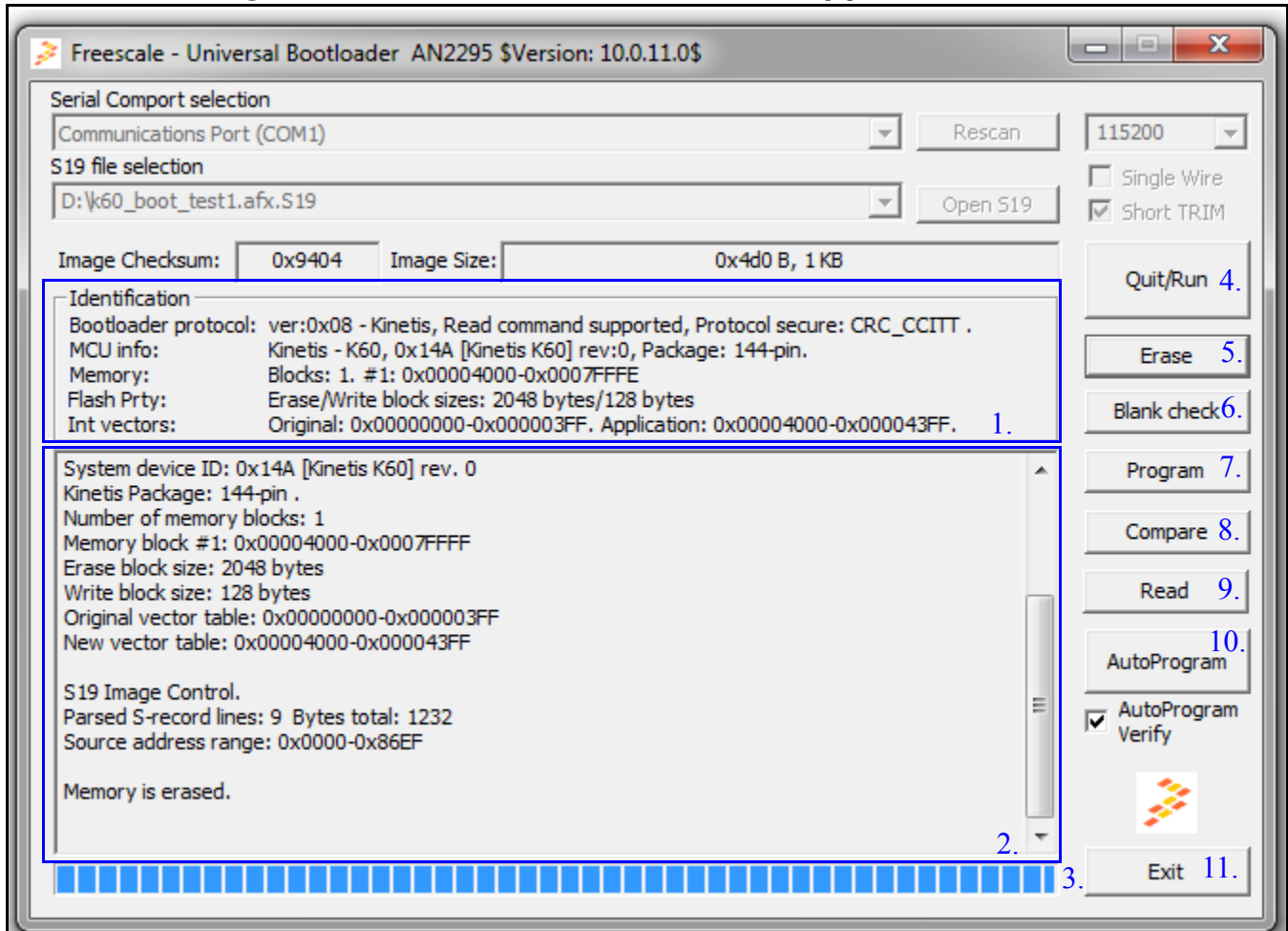

Figure 45. The Windows version of Bootloader window connected to target

1. Identification information - in this frame the application shows all known information about target and used AN2295 serial protocol.
2. Console window - this console window is showing exactly same information as the command line version of application.
3. Progress bar - progress bar is showing status of current active operation (erase, program, compare and so forth).
4. Quit/Run - This button ends the active bootloader session and invokes to run the user application if it's available.

Merging bootloader and application images

5. Erase - this button invokes erase of whole user flash memory area.
6. Blank check - this command check the memory if it's erased. The command is implemented by read command.
7. Program - the button try to download the prepared image to the target. Be sure that before this operation the target memory is already erased.
8. Compare - this button compare the content of the target memory with prepared image
9. Read - this command read the full target user area and store it into new S19 file.
10. AutoProgram - this command invoke exactly same procedure as is using command line version of the AN2295 master application. To add extra verification after write the image the AutoProgram Verify must be checked.
11. Exit - this button exits from the bootloader application

11 Merging bootloader and application images

This section provides a detailed description of the computer software that merges the bootloader and user application S19 files into one output S19 file, which is downloadable as a zip file from the Freescale Semiconductor website, freescale.com. All code is written in C language and is compatible with the Win32[®] platform.

Typical case of a merged bootloader and user application S19 file is the final mass production of the MCU flash image with bootloader capability. The merge tool simplifies the operation of flashing the bootloader itself by debugging the interface of bootloading the application by the flashed bootloader.

The merge tool application is using the same base of source files as all other AN2295 PC software (Master bootloader applications: command line and standard windows form versions).

The Merge tool windows form application is designed to load two S19 files (application and bootloader), and select the type of MCU and interrupt vector tables (original and redirected). The application also contains the log window that provides all detailed information on the merge process and all possible warnings.

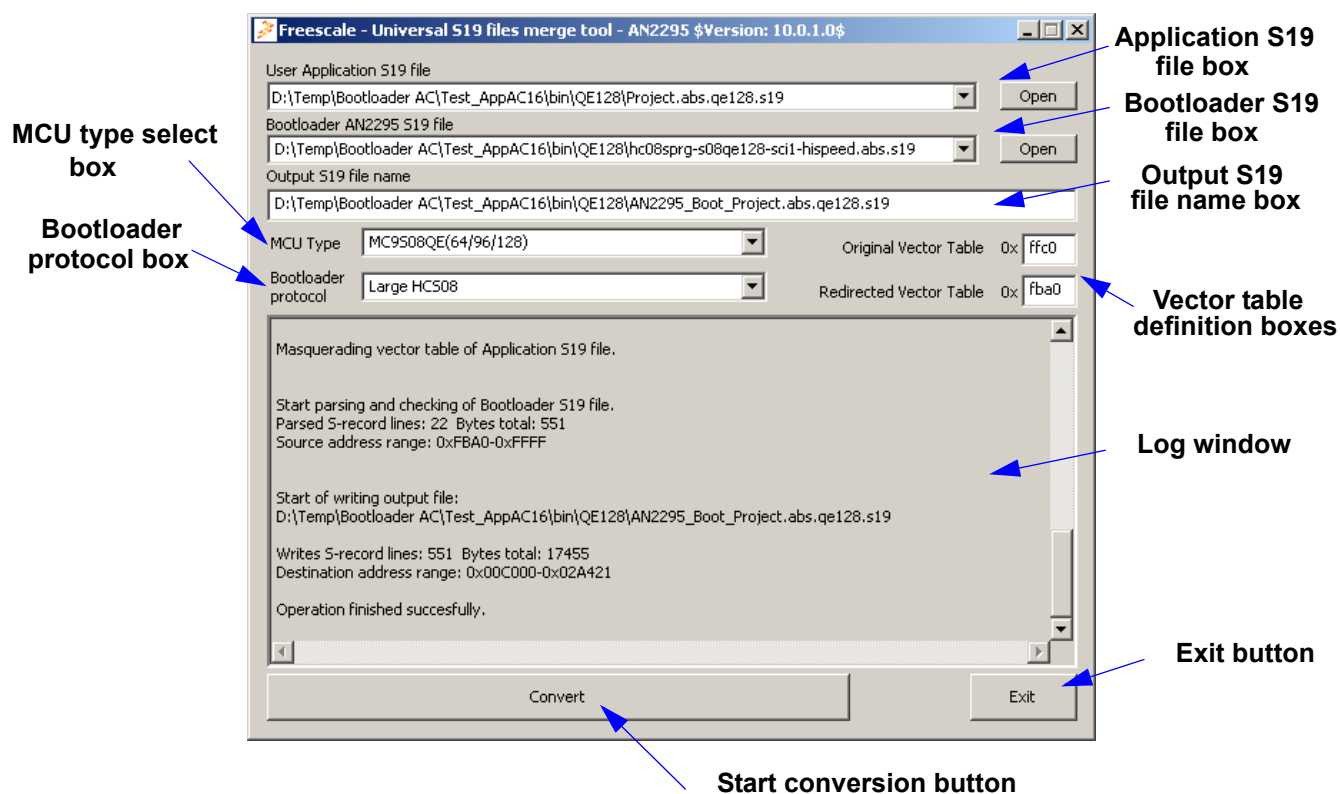

Figure 46. The AN2295 S19 Merge tool

12 References

For additional information, refer to these documents from the Freescale Semiconductor website, freescale.com

- AN2295SW: Contains all of the software files for this application note in a zip file.
- HCS08RMv1: *HCS08 Family Reference Manual Volume 1*
- AN1831: *Using MC68HC908 On-Chip FLASH Programming Routines*
- AN2140: *Serial Monitor for MC9S08GB/GT*
- AN2498: *Initial trimming of the MC68HC908 ICG*
- AN2504: *On-Chip FLASH Programming API for CodeWarrior Software*
- AN2508: *Generating Clocks for HC908 MCU Families*
- AN2545: *On-Chip FLASH Programming Routines for MC68HC908GR/GZ*
- AN2637: *Software SCI MC68HC908QT/QY MCU*
- AN2635: *On-Chip FLASH Programming Routines for LB8 and other FLASH-based MCUs*
- AN2874: *Using M68HC908 ROM-Resident Routines*
- AN3153: *Using the Full-Speed USB Module on the MCHC908JW32*

References

- ZSTARRM: *Wireless Sensing Triple Axis Reference design*
- CFPRM: *ColdFire® Family Programmer's Reference Manual*
- K60P100M100SF2RM: K60 Sub-Family Reference Manual
- AN3942: *Flash Programming Routines for the HCS08 and the ColdFire (V1) devices*
- The Master applications user guides: [Section 10, Master applications user guides](#)
- The description of Kinetis version of protocol including the changes in user application: [Section 7, FC protocol, version 5, Kinetis](#)
- The quick start guide how to modify the user Kinetis application to be ready for AN2295 bootloader: [Section 7.8, Quick guide: How to prepare the user Kinetis application for AN2295 bootloader](#)

How to Reach Us:

Home Page:
freescale.com

Web Support:
freescale.com/support

Information in this document is provided solely to enable system and software implementers to use Freescale Semiconductor products. There are no express or implied copyright licenses granted hereunder to design or fabricate any integrated circuits or integrated circuits based on the information in this document.

Freescale reserves the right to make changes without further notice to any products herein. Freescale makes no warranty, representation, or guarantee regarding the suitability of its products for any particular purpose, nor does Freescale assume any liability arising out of the application or use of any product or circuit, and specifically disclaims any and all liability, including without limitation consequential or incidental damages. "Typical" parameters that may be provided in Freescale data sheets and/or specifications can and do vary in different applications, and actual performance may vary over time. All operating parameters, including "typicals," must be validated for each customer application by customer's technical experts. Freescale does not convey any license under its patent rights nor the rights of others. Freescale sells products pursuant to standard terms and conditions of sale, which can be found at the following address: freescale.com/SalesTermsandConditions.

Freescale, the Freescale logo, ColdFire, and Kinetis are trademarks of Freescale Semiconductor, Inc., Reg. U.S. Pat. & Tm. Off. All other product or service names are the property of their respective owners. ARM and Cortex are the registered trademarks of ARM Limited.

© 2013 Freescale Semiconductor, Inc. All rights reserved.

Document Number: AN2295
Rev. 13
10/2013



