

Table of Contents

Page	Title
1	Title Page
2	Notes
3	Block Diagram
4	Primary_Elevator
5	Secondary_Elevator
6	MCU
7	SDRAM_LED_POWER
8	LVDS_RGB_I/F

Revisions

Rev	Date	Description
AX1	17-DEC-2012	I2C0 & I2C1 on Primary connected to I2C2 on Secondary CN1 & CN4 made DNP Part are replaced with Equivelent or Nearly Equivelent FCL part
B	08-Jan-2013	Rev B A085 Release

		Microcontroller Solutions Group 6501 William Cannon Drive West Austin, TX 78752-8689	
<small>This document contains information proprietary to Freescale Semiconductor and shall not be used for engineering design, procurement or manufacture in whole or in part without the express written permission of Freescale Semiconductor.</small>			
Designer: K.Mangula(LnT)		ICAP Classification: FCP: FUC: X PUB:	
Drawn by: K.Mangula(LnT)		TWR_LCD EPSON	
Approved: Villareal Jose Ramon		Title Page	
Size C	Document Number SCH-27539, SPP-27539	Date: Tuesday, January 08, 2013	Rev B
Date: Tuesday, January 08, 2013		Sheet 1 of 8	



ICAP Classification: FCP: FIUC: X PUBI: _____		
Drawing Title: TWR_LCDC_EPSON		
Page Title: Notes		
Size C	Document Number SCH-27539, SPF-27539	Rev B
Date: Tuesday, January 08, 2013	Sheet 2	of 8

Block Diagram

		
Drawing Title: TWR_LCDC_EPSON		
Page Title: Block Diagram		
Size C	Document Number SCH-27539, SPF-27539	Rev B
Date: Tuesday, January 08, 2013	Sheet 3	of 8

PRIMARY ELEVATOR

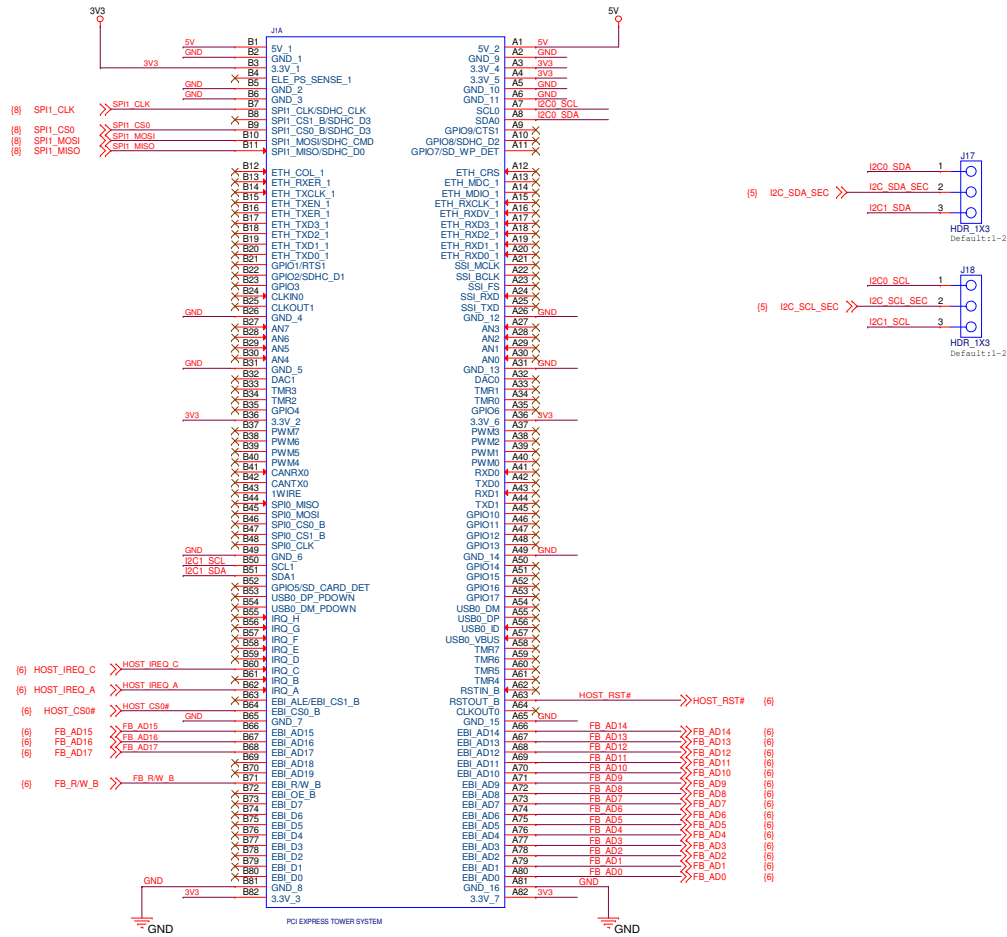

Bypass Capacitor

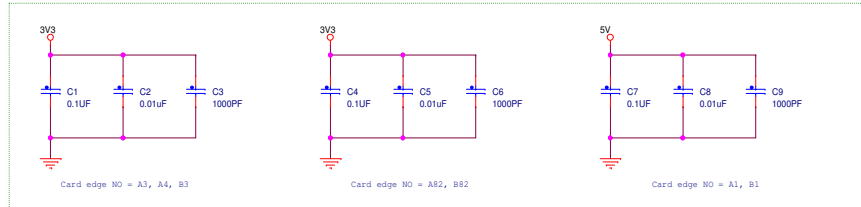

SECONDARY ELEVATOR

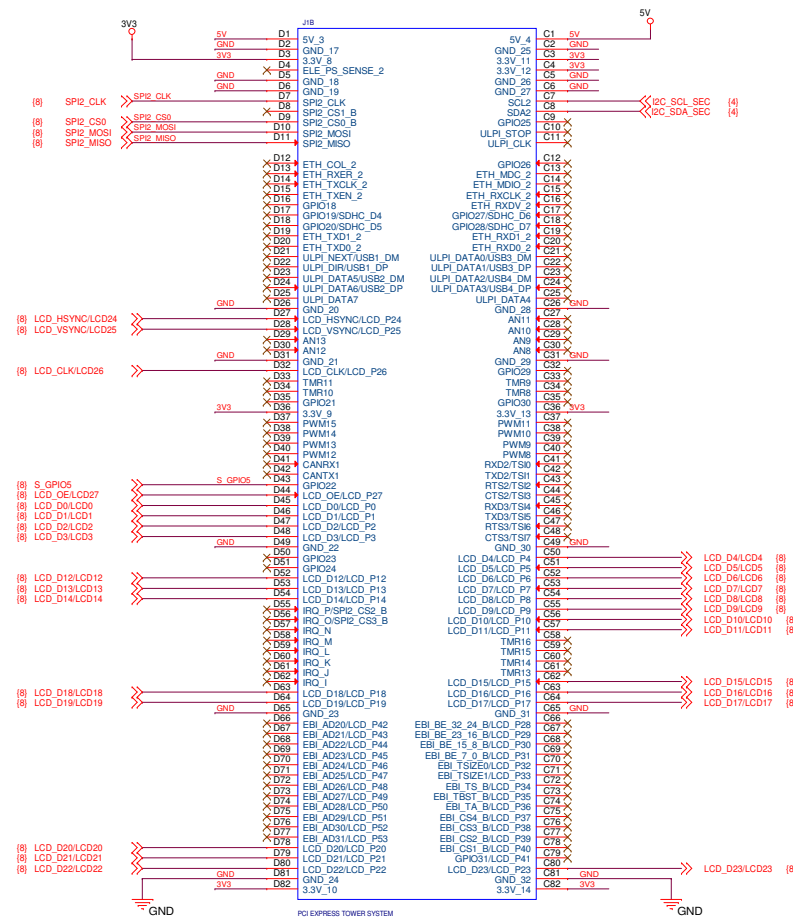

Bypass Capacitor

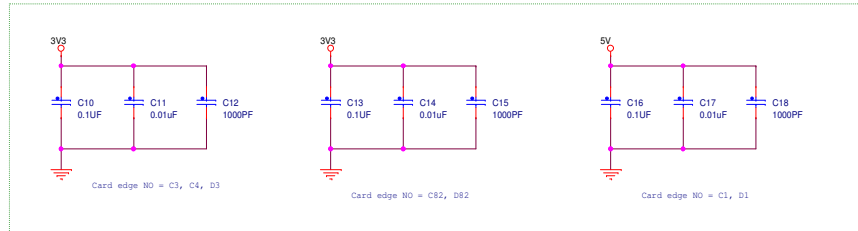

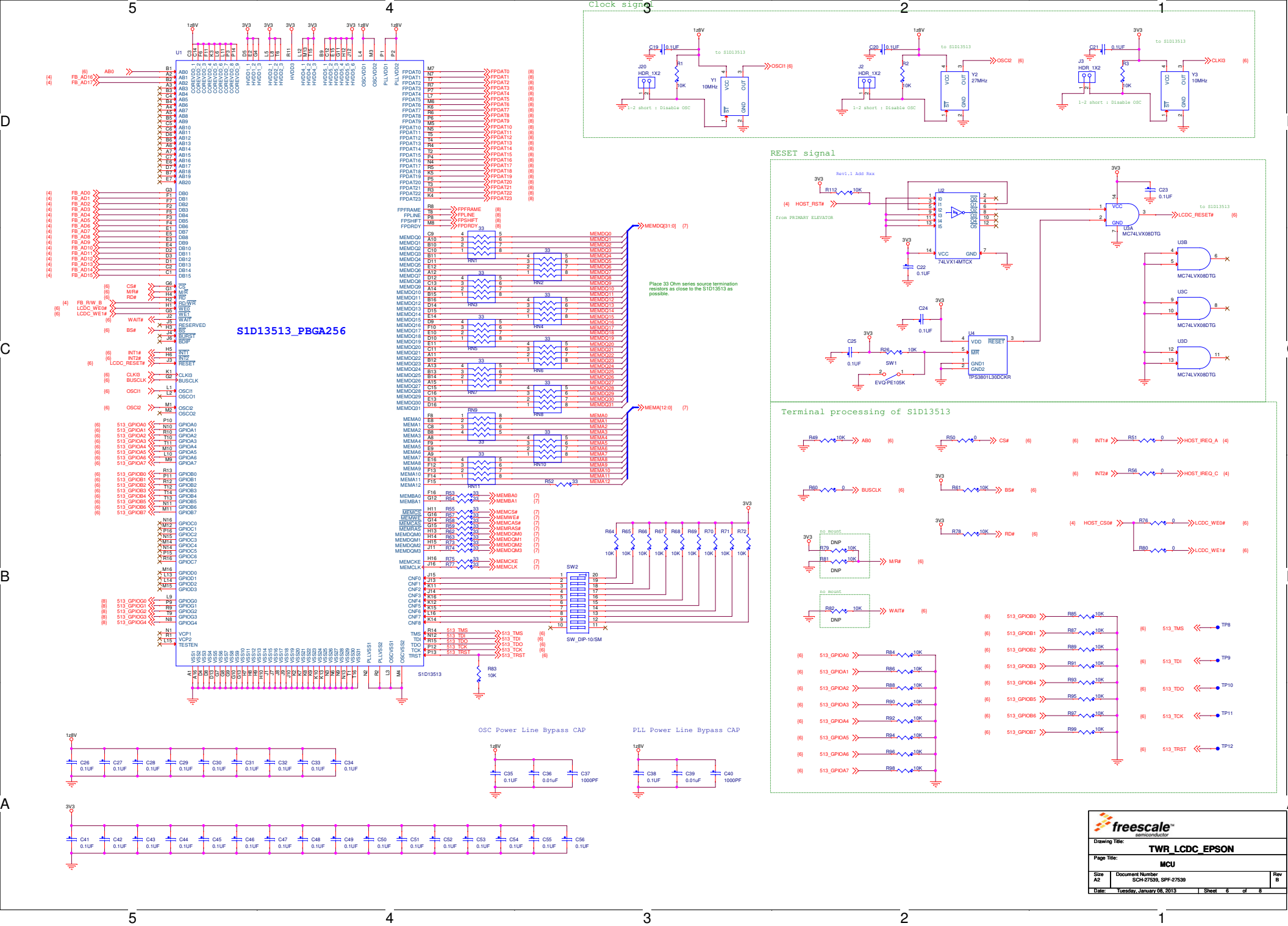

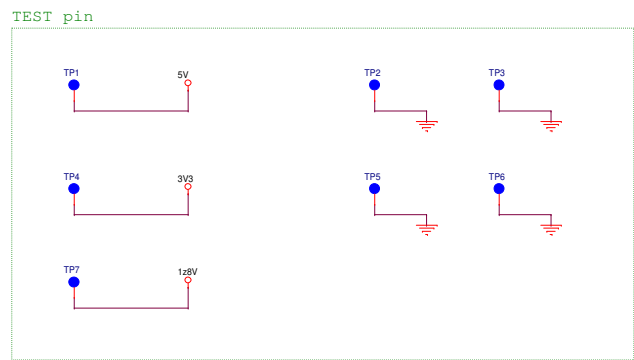
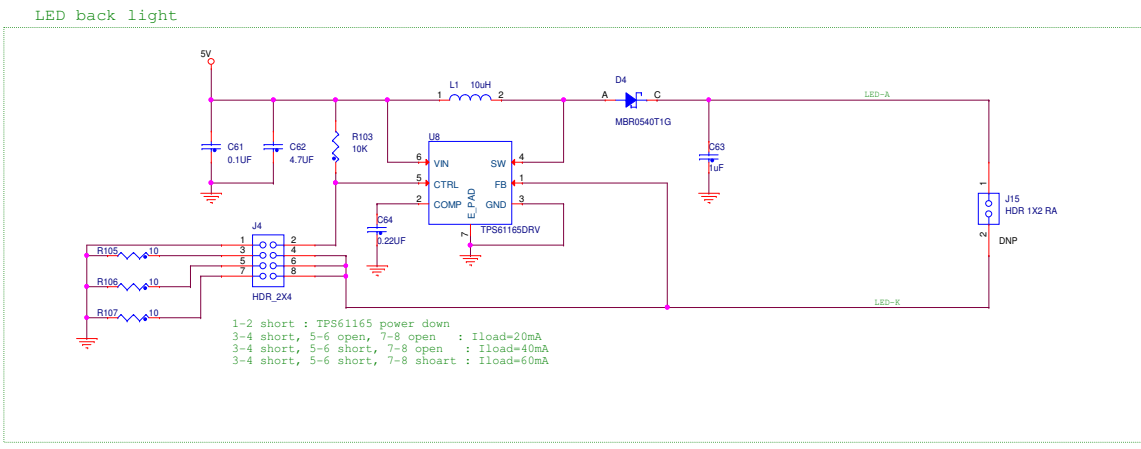
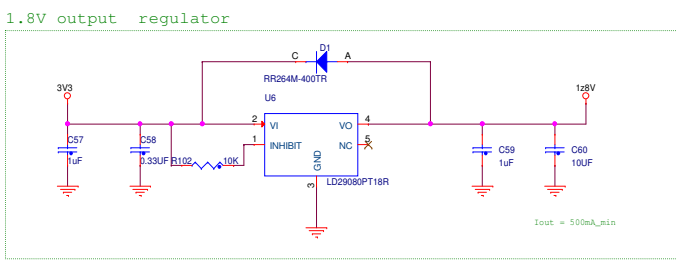
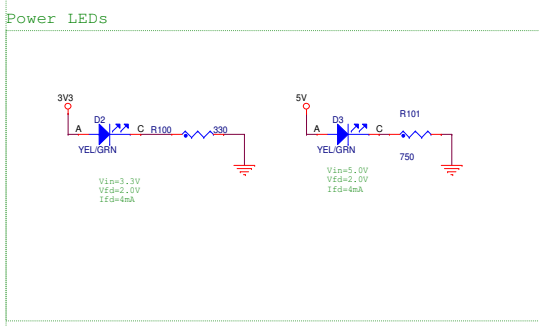
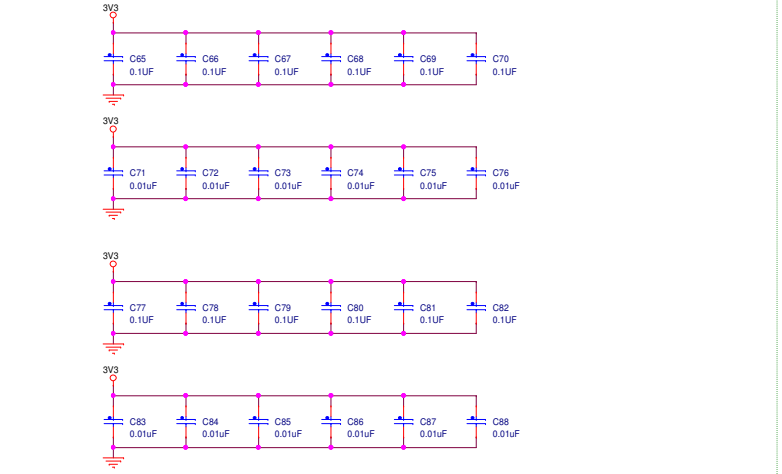
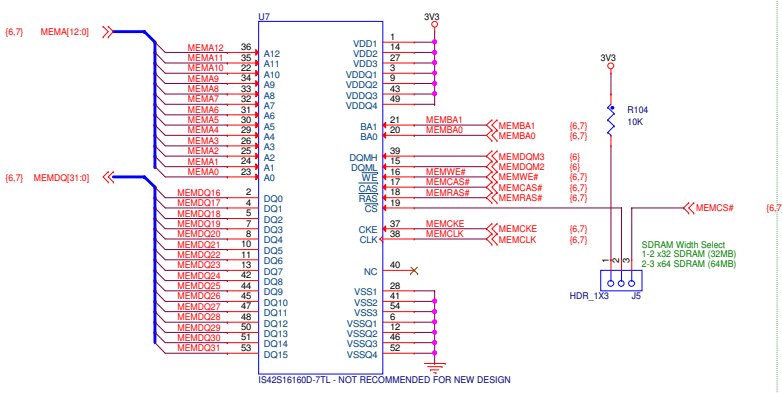
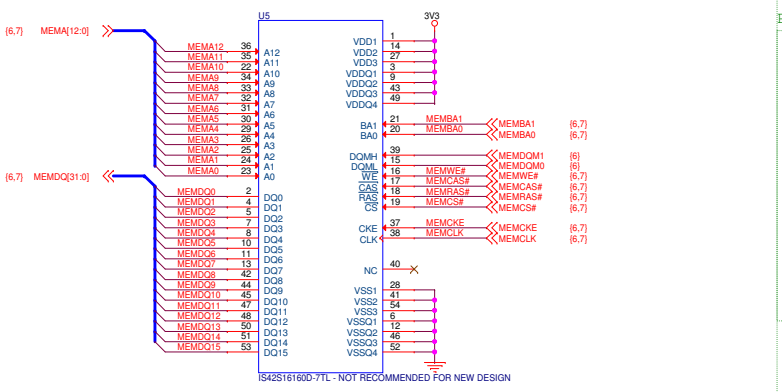

Pixel data to SECONDARY

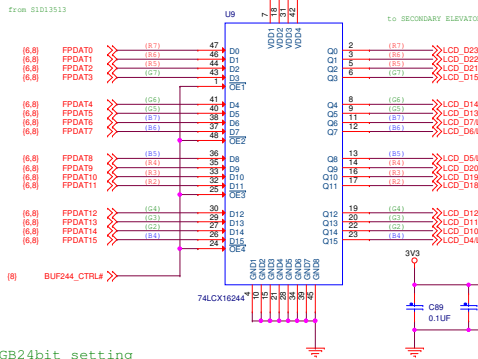

S1D13513 : RGB24bit setting

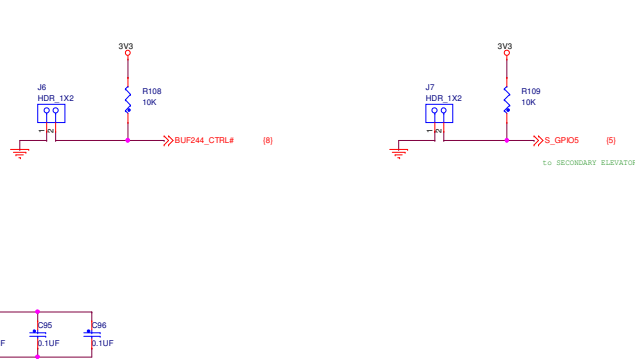
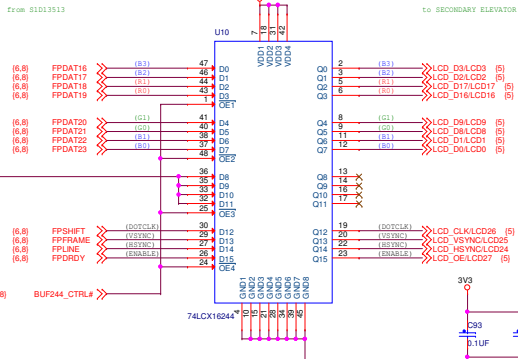

Reference *SPF-27218_B.pdf

LVDS-IF

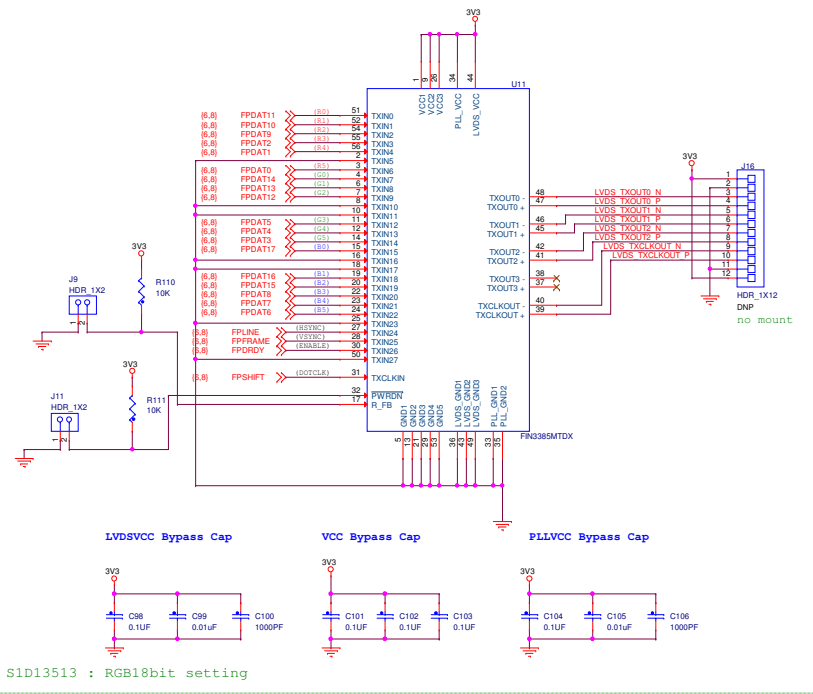

S1D13513 : RGB18bit setting

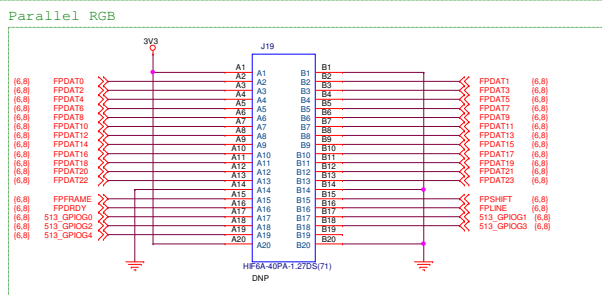

SPI-IF (PRIMARY - SECONDARY - GPIOG)

