

Table of Contents

1	Title
2	Block Diagram
3	KE02Z MCU
4	OpenSDA INTERFACE
5	I/O Headers and Power Supply

Revisions

Rev	Description	Date	Approved
A	Release based on FRDM-KE02Z A2 Change MCU to MKE02Z64VQH4 Change C18 from 1.0uF to 0.1uF	11/20/13	

FREEDOM KE02Z40M

		Automotive, Industrial & Multi-Market Solutions Group <small>6501 William Cannon Drive West Austin, TX 78735-8588</small>	
<small>ICAP Classification: FQP: FIUO: PUB: X</small>			
Designer:	Drawing Title: FRDM-KE02Z40M		
Drawn by:	Page Title: TITLE PAGE		
Approved:	Size C	Document Number SCH-28201 PDF: SPF-28201	Rev A
Date: Friday, November 22, 2013 Sheet 1 of 5			

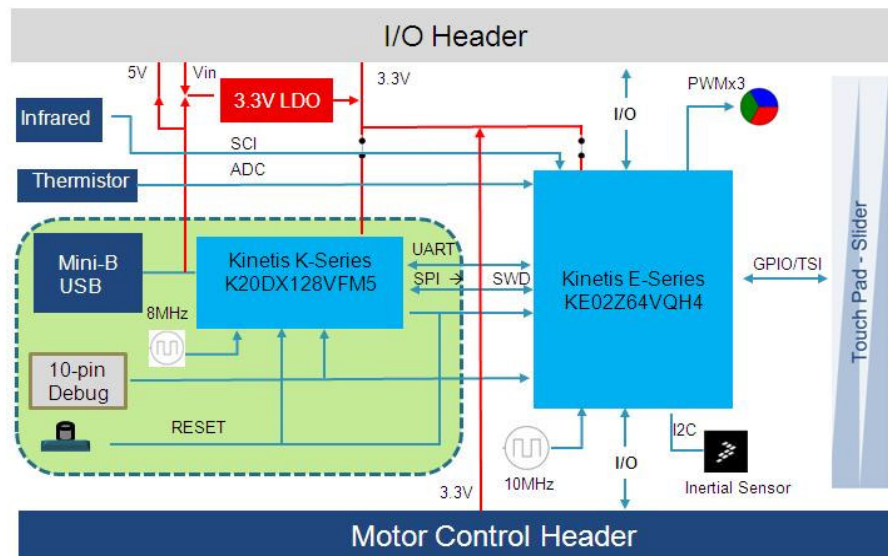

Indicates optional items that will not be populated by default

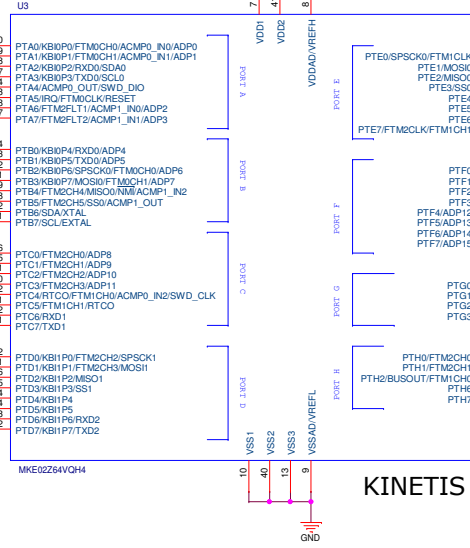
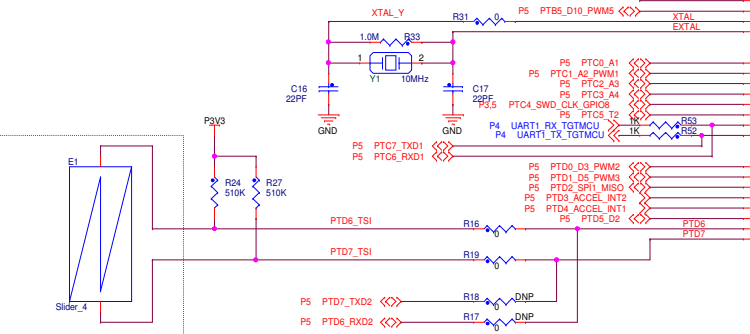
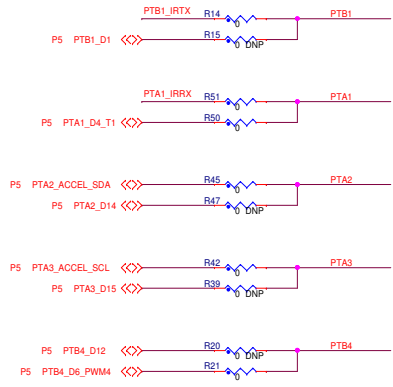

CAD NOTE: Please place these capacitors near their respective CPU pin VDD

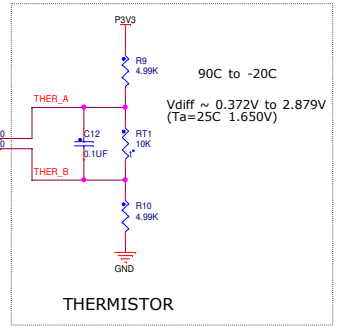

TSI CAPACITIVE/TOUCH INTERFACE

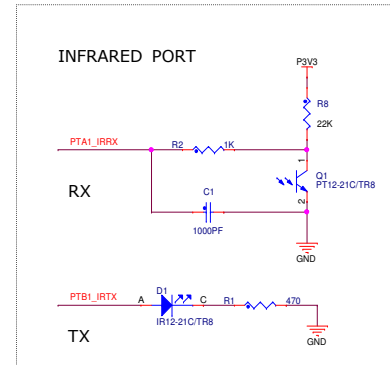
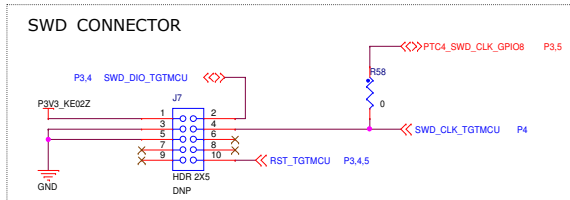
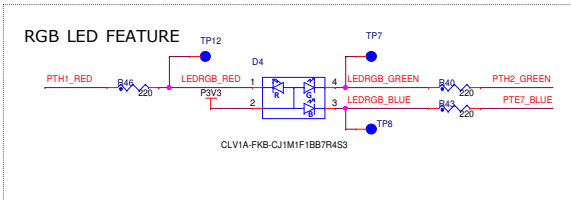

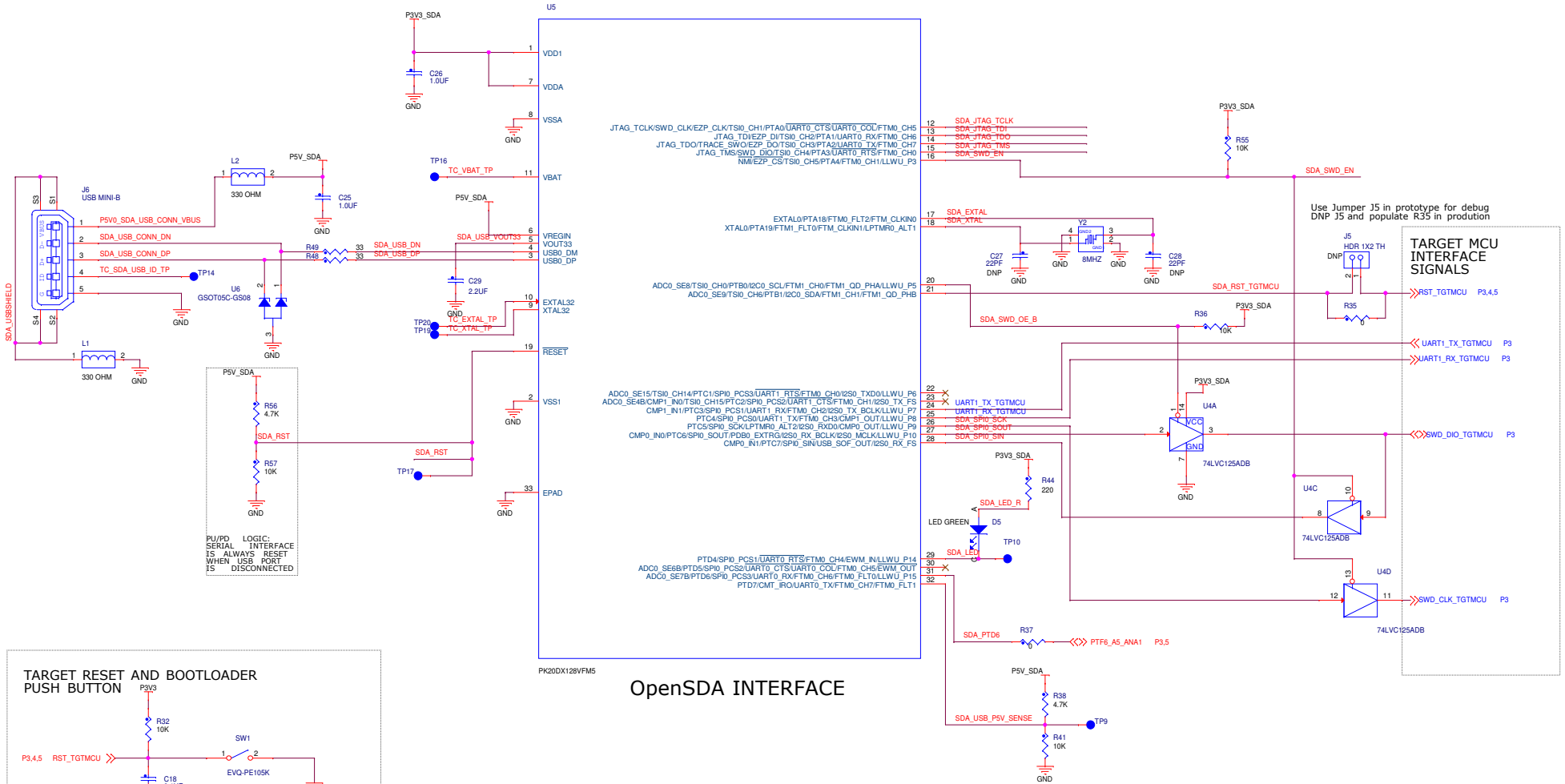

OpenSDA INTERFACE

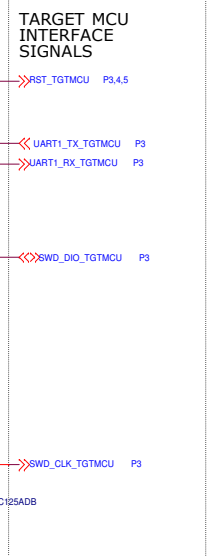
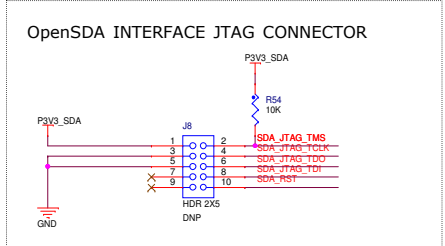
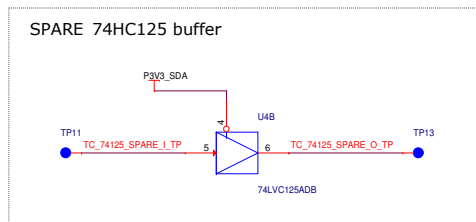
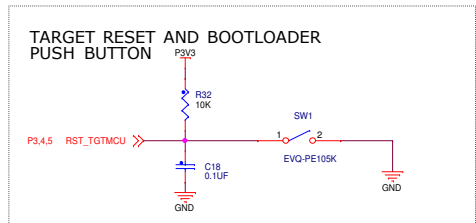

freescale

ICAP Classification: FCP: FIUO: PUBI: X
 Drawing Title: **FRDM-KE02Z40M**
 Page Title: **OpenSDA interface**

Size C	Document Number SCH-28201 PDF: SPF-28201	Rev A
Date: Wednesday, November 20, 2013	Sheet 4 of 5	

