

MIMXRT1015-EVK

Blcok Diagram Rev B#####

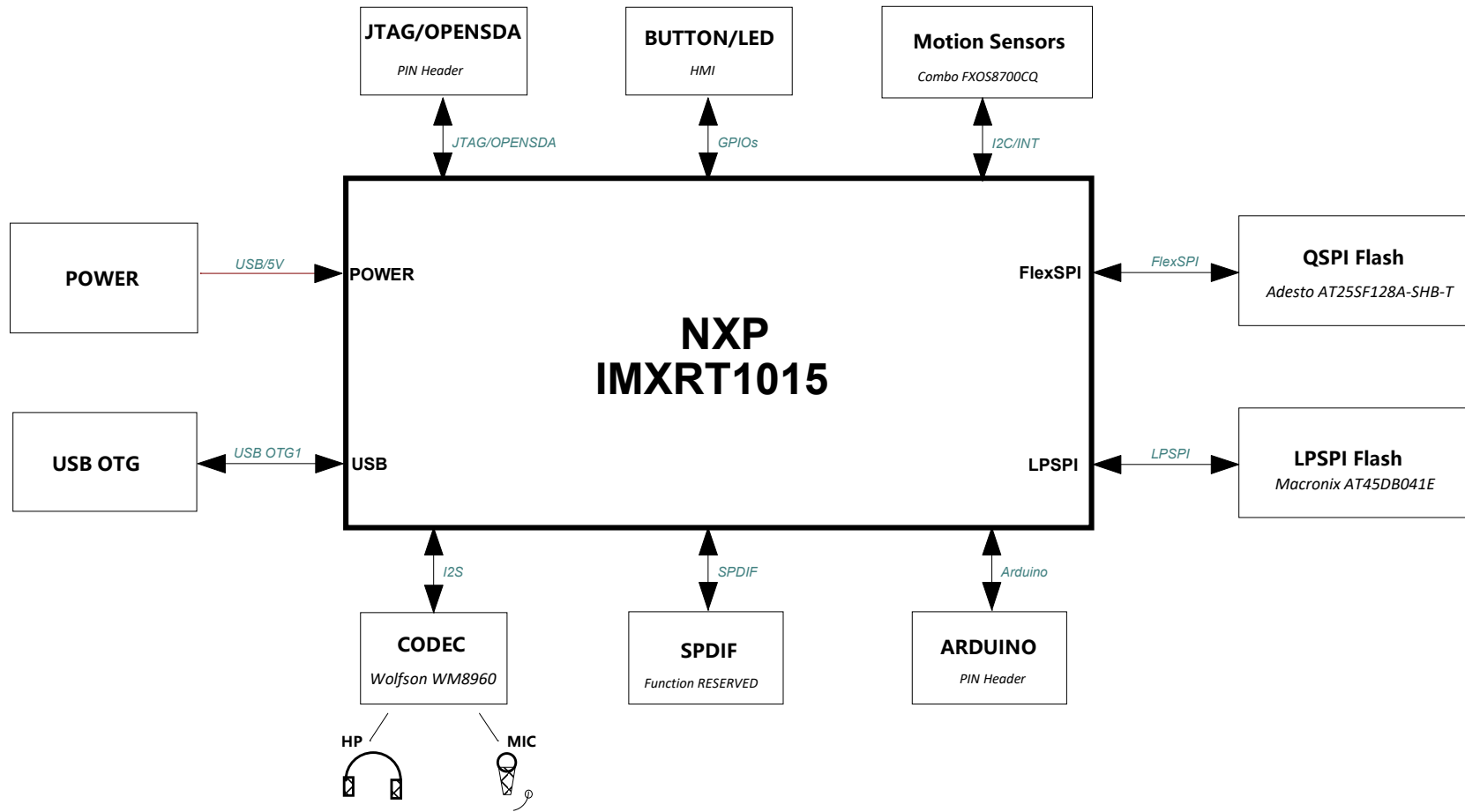

ICAP Classification: CP: IUC: PUB:			
Drawing Title: MIMXRT1015-EVK			
Page Title: BLOCK DIAGRAM			
Size C	Document Number	SCH-38830, PDF: SPF-38830	Rev B
Date: Thursday, November 29, 2018		Sheet 2	of 13

Main Power

USB POWER SUPPLY

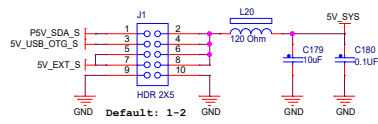

5V_EXT_S is for external supply

3V3 LDO for SNVS

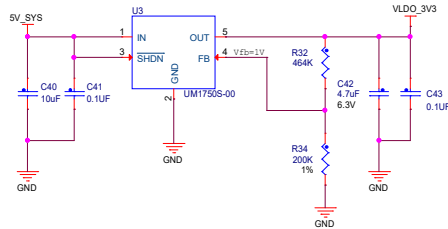

VDDHIGH / NVCC_XXX

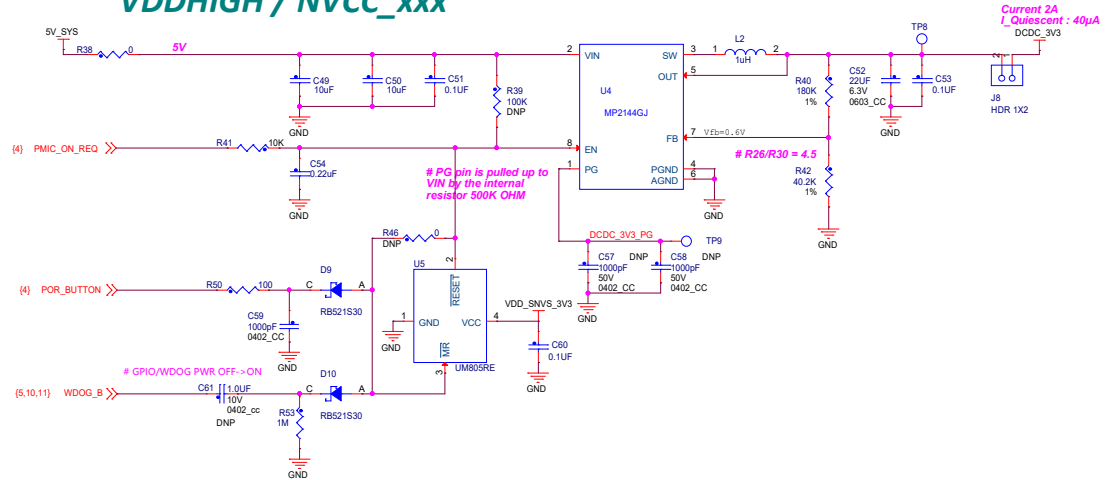

SNVS

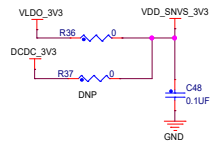

ADC

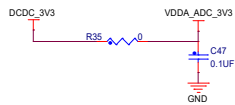

DCDC_IN

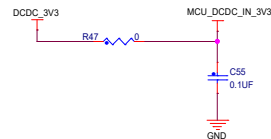

VDD_HIGH_IN

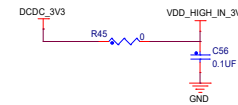

Ground TPs

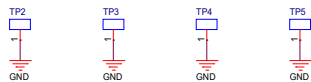

Layout Note: Place Ground TPs to assist signal measurement.

Board Mounting Holes

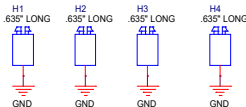

ICAP Classification: CP: IUC: PUBI:	
Drawing Title: MIMXRT1015-EVK	
Page Title: MAIN POWER	
Size C	Document Number SCH-38830, PDF: SPF-38830
Date: Thursday, November 29, 2018	Sheet 3 of 13

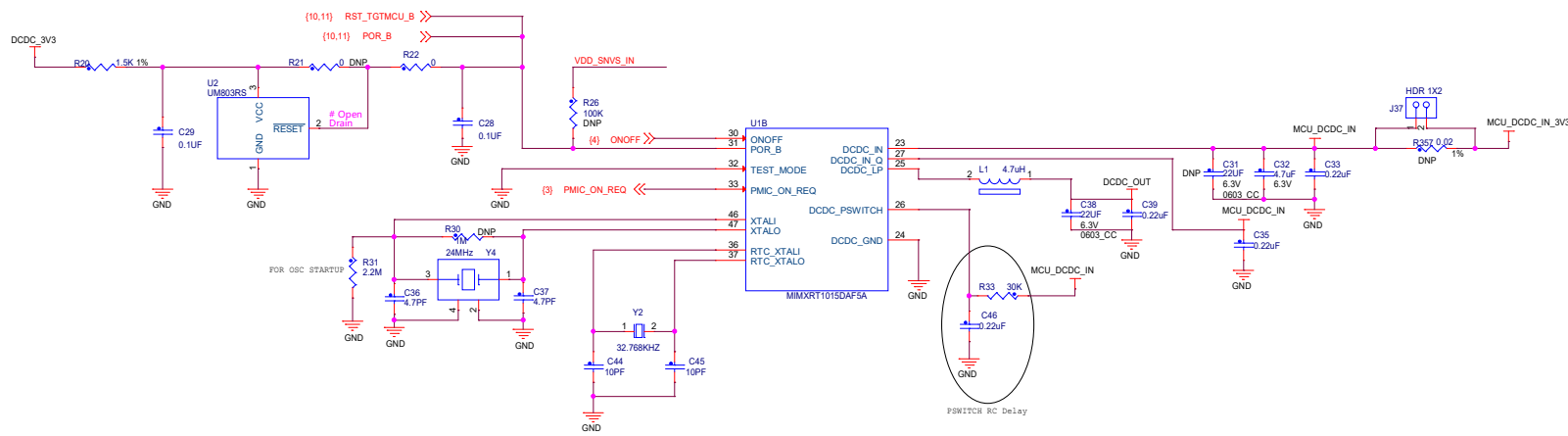
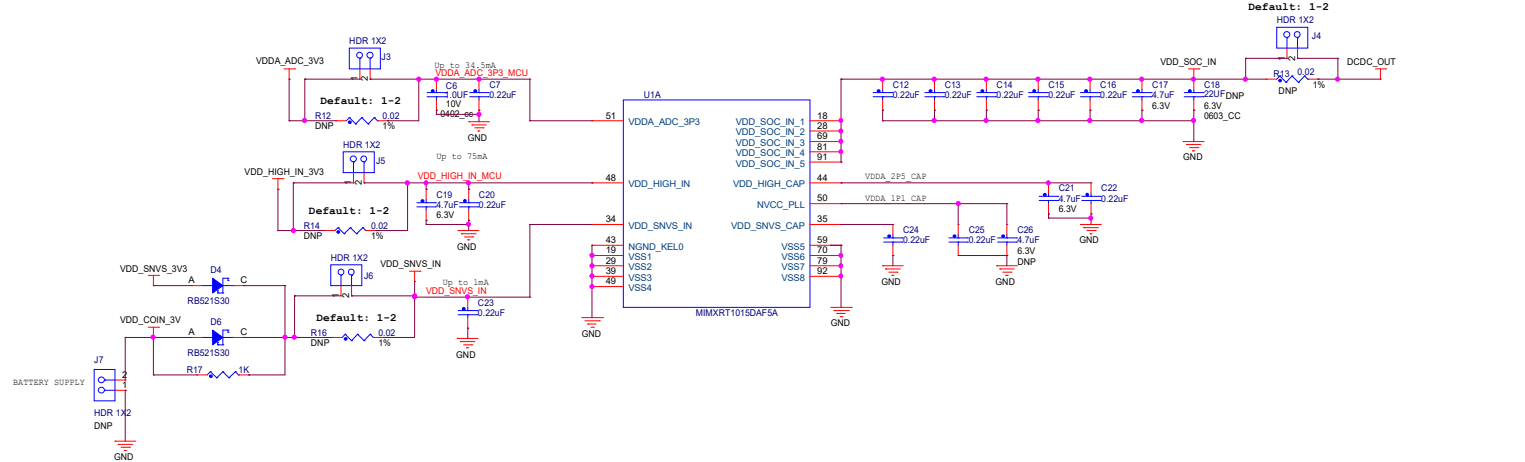

BUTTON

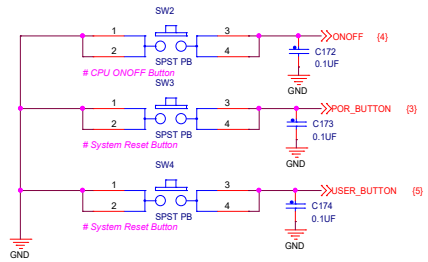

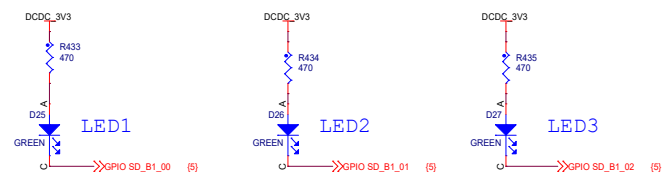

USER LEDS

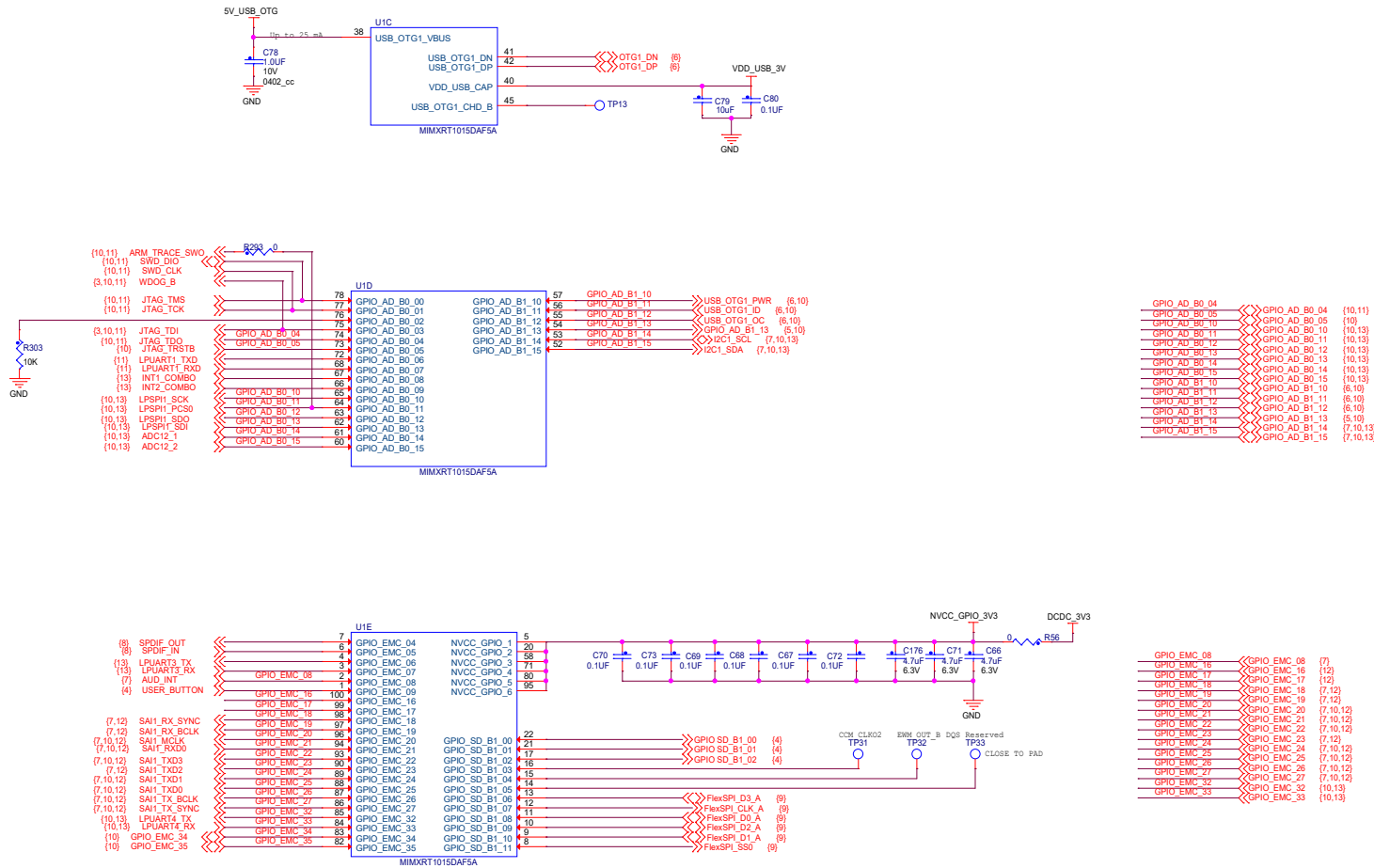

ICAP Classification: CP: IUC: PUB:			
Drawing Title: MIMXRT1015-EVK			
Page Title: MIMXRT1015DAF5A PART1			
Size C	Document Number SCH-38830, PDF-SPF-38830	Rev B	
Date: Thursday, November 29, 2018	Sheet 4	of 13	

MCU PINOUT





ICAP Classification: CP: IUC: PUB:	
MIMXRT1015-EVK	
Page Title: MIMXRT1015DAF5A PART2	
Size C	Document Number SCH-38830, PDF-SPF-38830
Date: Thursday, November 29, 2018	Sheet 5 of 13

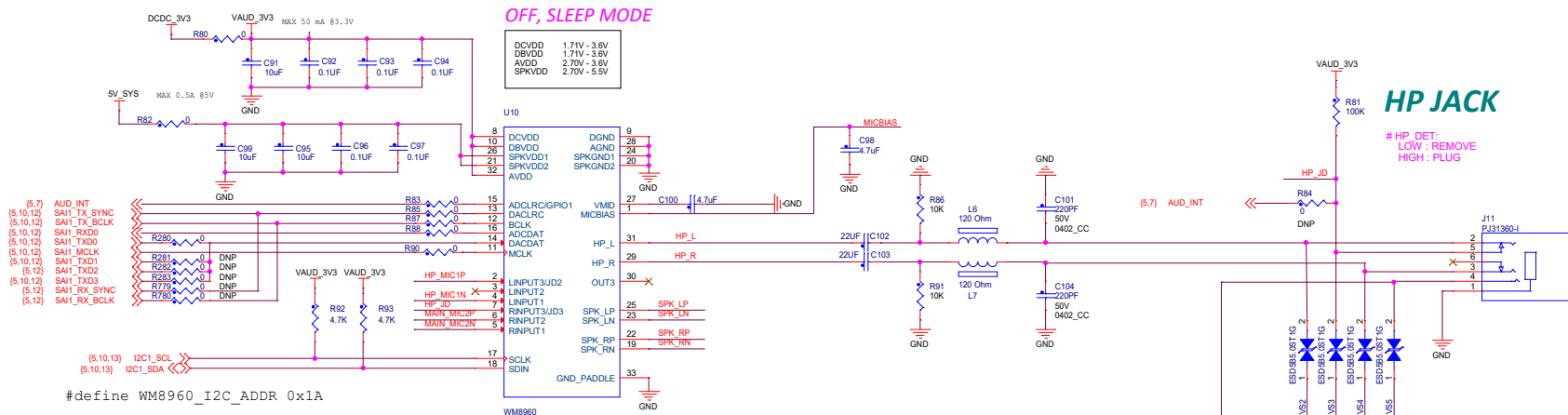

Main Board MIC

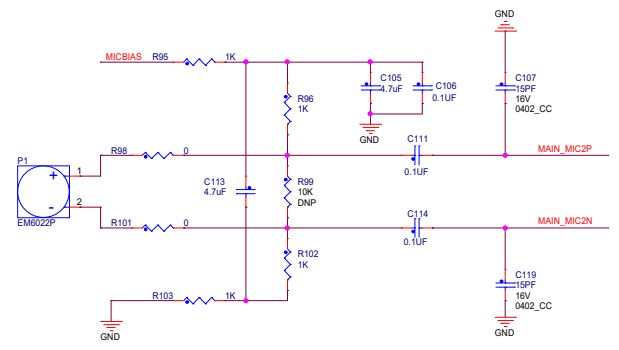

HP MIC

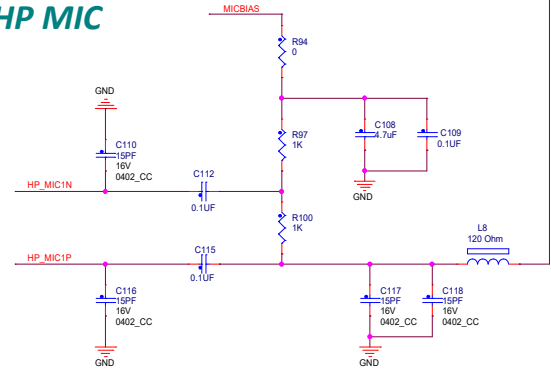

Speaker

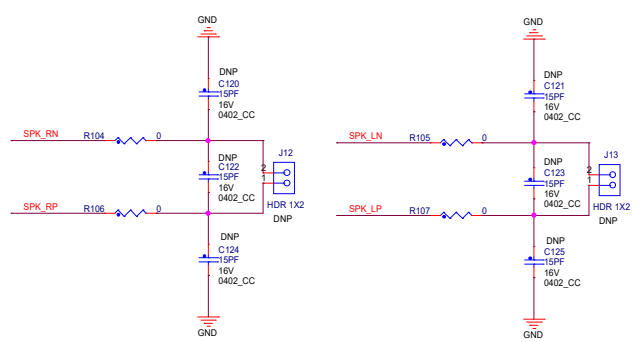

ICAP Classification: CP: IUC: PUB:

Drawing Title: **MIMXRT1015-EVK**

Page Title: **SAI**

Size C	Document Number SCH-38830, PDF: SPF-38830	Rev B
Date: Thursday, November 29, 2018	Sheet 7 of 13	

SPDIF Interface

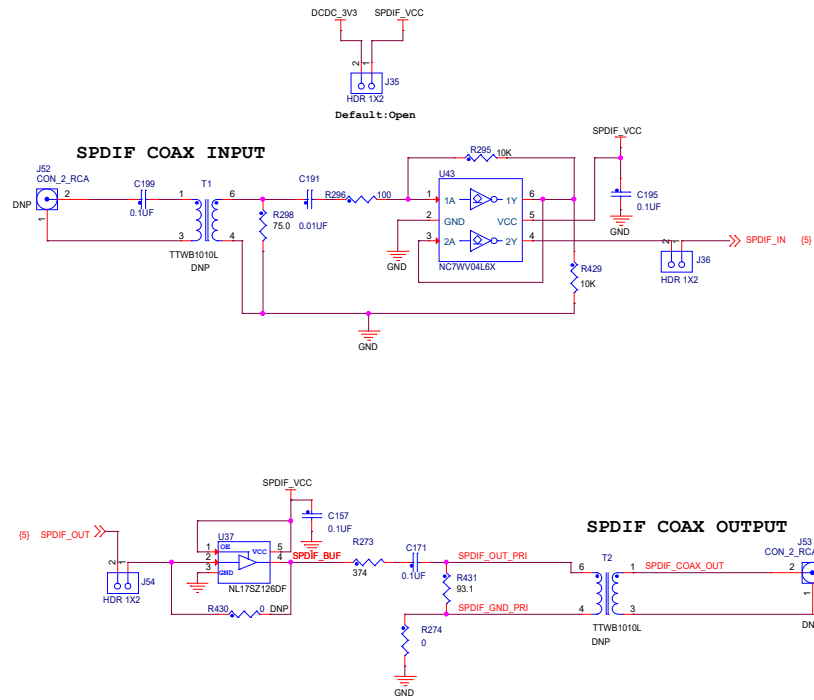

ICAP Classification: CP: IUC: PUB:	
Drawing Title: MIMXRT1015-EVK	
Page Title: SPDIF	
Size C	Document Number SCH-38830, PDF: SPF-38830
Date: Monday, December 03, 2018	Sheet 8 of 13

3v3 QSPI Flash

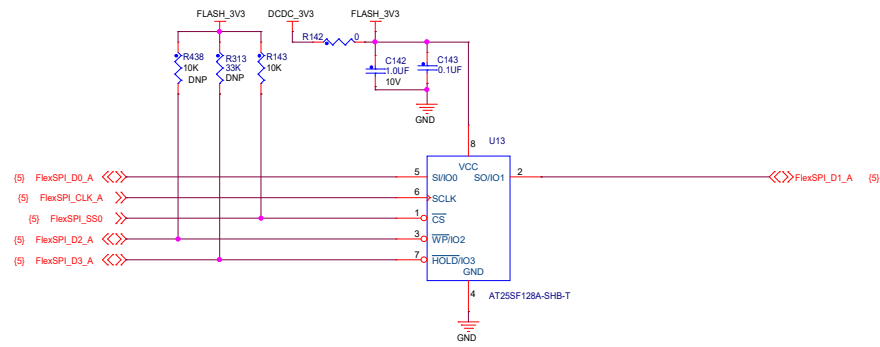

ICAP Classification:		CP:	IUC:	PUB:
Drawing Title:				
MIMXRT1015-EVK				
Page Title:				
FLEXSPI FLASH				
Size	Document Number	SCH-38830, PDF-SPF-38830		Rev
C				B
Date:	Thursday, November 29, 2018	Sheet	8	of 13

JTAG Connector

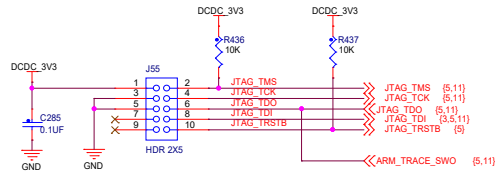

Arduino Interface

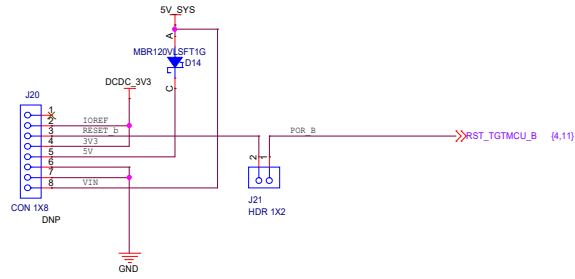
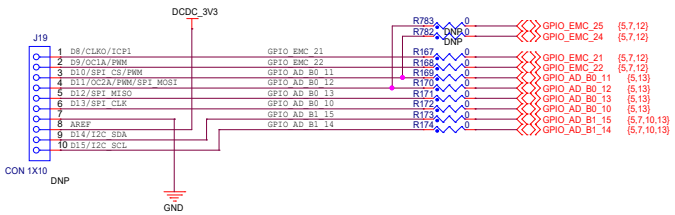
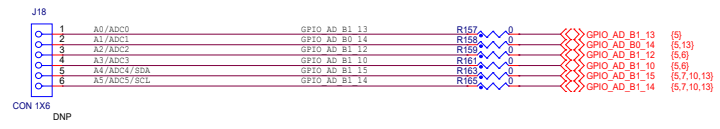
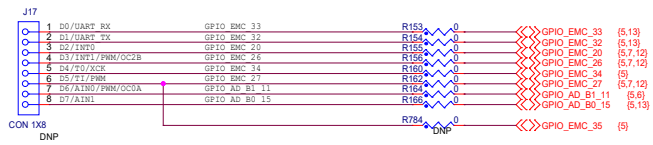

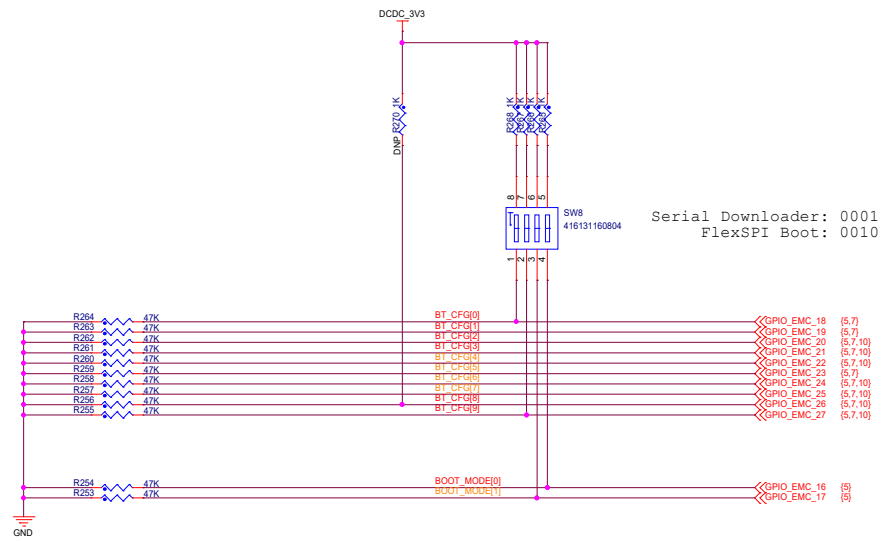

ICAP Classification: CP: IUC: PUB:	
Drawing Title: MIMXRT1020-EVK	
Page Title: BOOT	
Size C	Document Number SCH-38830, PDF: SPF-38830
Date: Thursday, November 29, 2018	Sheet 12 of 13

COMBO SENSOR

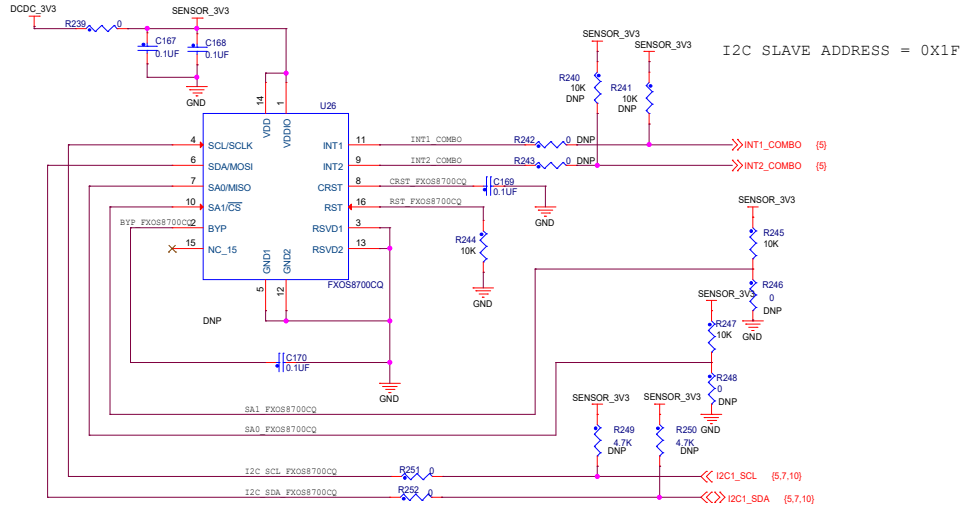

FXOS8700CQ COMBO SENSOR

ADC Sampling

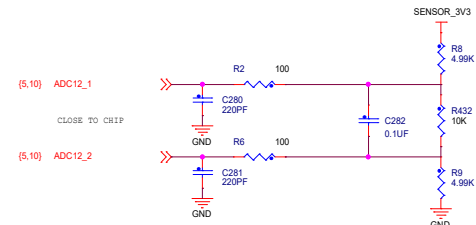

LPSPi Flash

