

# Rocktech Displays Limited



Module P/N: RK070CU05H

Version: 1.0

Description : 7.0 inch TFT 1024\*600 pixels with LED  
backlight ,All viewing angle,MIPI interface,  
1000 nits luminance

TEL: 0086-755-26065260

Fax: 0086-755-26065261

E-mail: [Sales@rocktech.com.hk](mailto:Sales@rocktech.com.hk)

Web: [www.rocktech.com.hk](http://www.rocktech.com.hk)

**Revision History**

<b>Date</b>	<b>Rev.</b>	<b>Page</b>	<b>Description</b>
<b>2019-08-16</b>	<b>1.0</b>	<b>All</b>	<b>First Issue</b>

# CONTENTS

- GENERAL FEATURES
- ABSOLUTE MAXIMUM RATINGS
- ELECTRICAL SPECIFICATIONS
- OPTICAL SPECIFICATIONS
- BLOCK DIAGRAM
- PIN DESCRIPTION
- TIMING CHARACTERISTICS
- OUTLINE DIMENSION
- RELIABILITY AND INSPECTION STANDARD
- PRECAUTIONS

**1. General Features**

<b>Item</b>	<b>Spec</b>	<b>Remark</b>
Display Mode	Normally Black transmissive	
Viewing Direction	Free	
Input Signals	MIPI	
Outside Dimensions(mm)	164.9 (W) x100(H) x5.7 (D)	
Active Area(mm)	154.21(W)× 85.92(H)	
Number of Pixels	1024(RGB)×600	
Dot Pitch(mm)	0.1506 (H) x 0.1432 (V)	
Pixel Arrangement	RGB Vertical stripes	
Drive IC	---	

## 2. Absolute Maximum Ratings

The following are maximum values which, if exceeded may cause operation or damage to the unit.

ITEM	Sym.	Min.	Typ.	Max.	Unit	Remark
Power for Circuit Driving	VDD	-0.3	-	+2.0	V	
	AVDD	-0.5		15.0	V	
	VGH	-0.3		40	V	
	VGL	-20		0.3	V	
Storage Humidity	H <sub>ST</sub>	10	-		%RH	At 25±5°C
Storage Temperature	T <sub>ST</sub>	-30	-	80	°C	
Operating Ambient Humidity	H <sub>OP</sub>	10	-		%RH	
Operating Ambient temperature	T <sub>OP</sub>	-20	-	70	°C	

### 3. Electrical Specification

#### 3.1 Driving TFT LCD Panel

Item	Symbol	Min.	Typ.	Max.	Unit	Note
Supply Voltage	V <sub>DD</sub>	1.71	1.8	1.89	V	
	V <sub>GH</sub>	17	18	19	V	
	V <sub>GL</sub>	-6.6	-6	-5.4	V	
	AV <sub>DD</sub>	9.4	9.6	9.8	V	
	V <sub>com</sub>	3.6	3.8	4.0		
Video signal amplitude (V <sub>R</sub> ,V <sub>G</sub> ,V <sub>B</sub> )	V <sub>IA</sub>	-	-	AV <sub>DD</sub> -0.4	V	
	V <sub>IAC</sub>	-	-	-	V	AC component,
	V <sub>IDC</sub>	-	AV <sub>DD</sub> /2	-	V	DC component
VCOM	V <sub>CAC</sub>		-	-	VP-P	AC component
	V <sub>CDC</sub>	-	-	-	V	DC component, (1)
Input signal voltage	V <sub>IH</sub>	0.7DV <sub>DD</sub>	-	DV <sub>DD</sub>	V	(2)
	V <sub>IL</sub>	0	-	0.3DV <sub>DD</sub>	V	(2)
Current of power supply	I <sub>DD</sub>	-	30	45	mA	DV <sub>DD</sub> =3.3V
	I <sub>ADD</sub>	-	35	45	mA	AV <sub>DD</sub> =9.6V
	I <sub>GH</sub>	-	0.5	1	uA	V <sub>GH</sub> =18V
	I <sub>GL</sub>	-	0.5	1	mA	V <sub>GL</sub> =-6V

Note (1): The brightness of LCD panel could be changed by adjusting the AC component of VCOM.

Note (2): STHL, STHR, OEH, L/R, CPH1~CPH3, STVD, STVU, OEV, CKV, U/D

#### 3.2 Driving LED Backlight

Item	Sym.	Min	Typ.	Max	Unit	Note
Backlight driving voltage	V <sub>F</sub>	9.0	9.6	10.2	V	
Backlight driving current	I <sub>F</sub>	-	270	-	mA	
Backlight Power Consumption	W <sub>BL</sub>	-	2592	-	mW	
Life Time	-	-	30,000	-		Note 1

Note 1: If LED is driven by high current, high ambient temperature & humidity condition. The life time of LED will be reduced. Operating life means brightness goes down to 50% initial brightness. Typical operating life time is estimated data.

### 3.3 Power Consumption

ITEM	SYMBOL	CONDITION	MIN	TYPE	MAX	UNIT	NOTE
Gate on power current	IVGH	VGH = 18V	--	0.5	1	mA	Note1
Gate off power current	IVGL	VGL = -6V	--	0.5	1	mA	Note1
Digital power current	IDVDD	DVDD = 3.3V	--	30	45	mA	Note1
Analog power current	IAVDD	AVDD = 9.6V	--	35	45	mA	Note1
Total Power Consumption	PC		--	447	604	mW	Note1

Note1: Typ. specification : Gray-level test Pattern

Max. specification : Black test Pattern



256 gray pattern



Black Pattern

#### 4. Optical Specifications

Optical characteristics are determined after the unit has been 'ON' and stable for approximately 30 minutes in a dark environment at 25 °C. The values specified are at an approximate distance 500mm from the LCD surface at a viewing angle of  $\Phi$  and  $\theta$  equal to 0°.

Item	Sym.	Values			Unit	Note
		Min.	Typ.	Max.		
1) Contrast Ratio	C/R	-	800	-		FIG.1
2) Module Luminance	L	-	1000	-	cd/m <sup>2</sup>	
3) Response time	Tr+Tf	-	35	-	ms	FIG.2
4) Viewing Angle	$\theta_T$	-	85	-	Degree	FIG.3
	$\theta_B$	-	85	-		
	$\theta_L$	-	85	-		
	$\theta_R$	-	85	-		
5) Chromaticity	Wx	0.27	0.31	0.35		
	Wy	0.29	0.33	0.37		
	Rx	-	-	-		
	Ry	-	-	-		
	Gx	-	-	-		
	Gy	-	-	-		
	Bx	-	-	-		
	By	-	-	-		



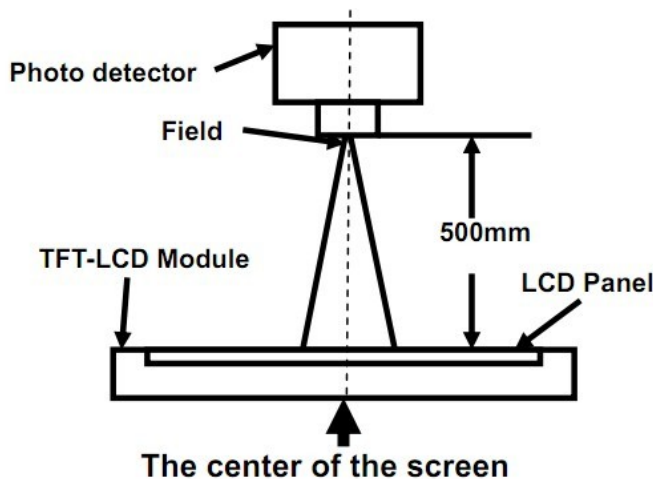
## ◆ Measurement System

Notes:

1. Contrast Ratio(CR) is defined mathematically as :  

$$\text{Contrast Ratio} = \frac{\text{Surface Luminance with all white pixels}}{\text{Surface Luminance with all black pixels}}$$
2. Surface luminance is the center point across the LCD surface 500mm from the surface with all pixels displaying white. For more information see FIG 1.
3. Response time is the time required for the display to transition from white to black (Rising Time, Tr) and from black to white (Falling Time, Tf). For additional information see FIG 2.
4. Viewing angle is the angle at which the contrast ratio is greater than 10. The angles are determined for the horizontal or x axis and the vertical or y axis with respect to the z axis which is normal to the LCD surface. For more information see FIG 3.

**FIG. 1 Optical Characteristic Measurement Equipment and Method**



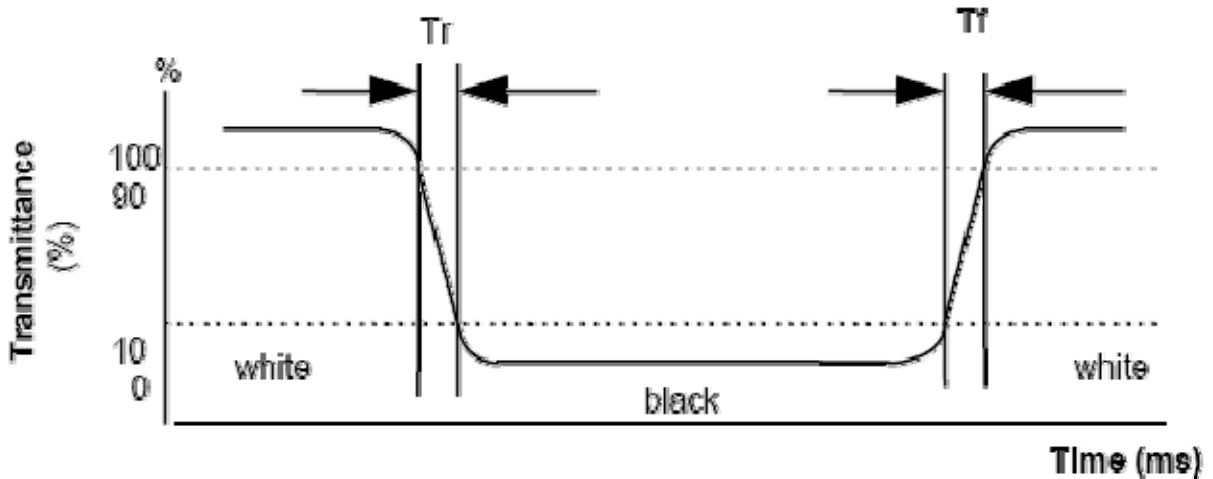
Item	Photo detector	Field
Contrast Ratio	SR-3A	1°
Luminance		
Chromaticity		
Lum Uniformity	BM-7A	2°
Response Time		

**FIG. 2 The definition of Response Time**

The response time is defined as the following figure and shall be measured by switching the input signal for “black” and “white”.

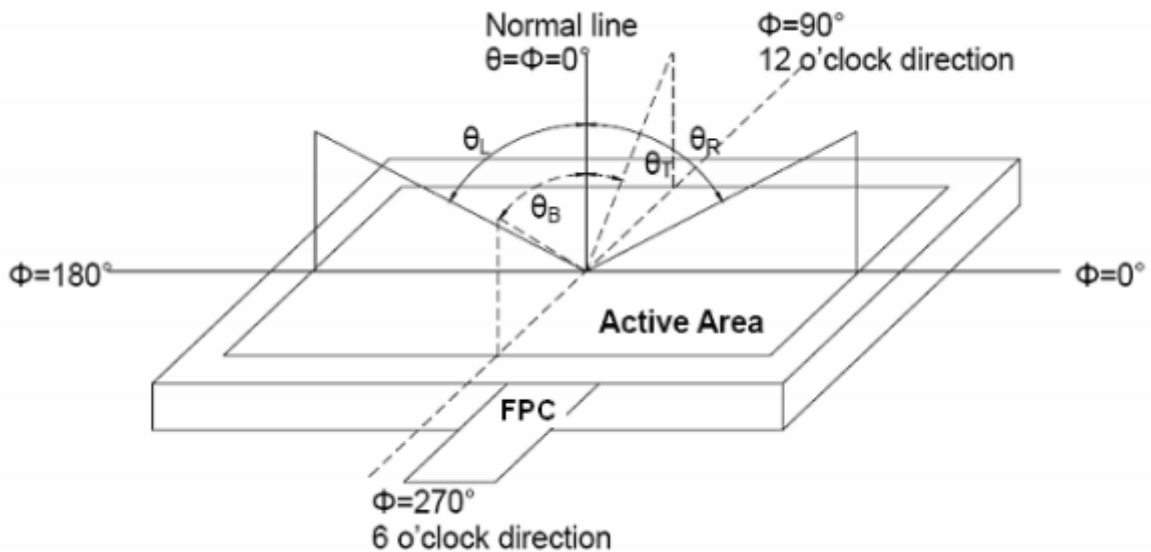
Response Time = Rising Time( $T_r$ ) + Falling Time( $T_f$ )

- Rising Time( $T_r$ ) : Full White 90% → Full White 10% Transmittance.
- Falling Time( $T_f$ ) : Full White 10% → Full White 90% Transmittance.

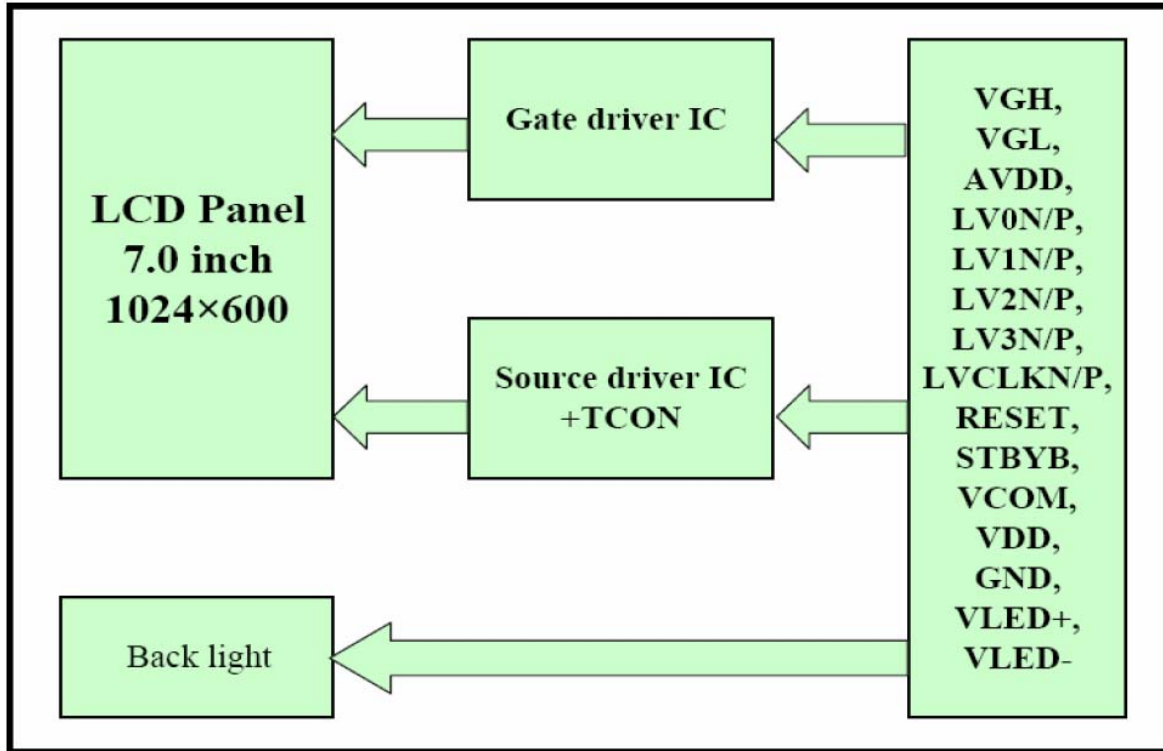


**FIG. 3 The definition of Viewing Angle**

Use Fig. 1 (Test Procedure) under Measurement System to measure the contrast from the measuring direction specified by the conditions as the following figure.



## 5. Block Diagram



## 6.Pin Description

### 6.1 TFT LCD Panel

PIN No.	Symbol	I/O	Function	Remark
1	VCOM	P	Common Voltage	
2	VDD	P	Power Supply 1.8V	
3	VDD	P	Power Supply 1.8V	
4	NC	-	No connection	
5	RESET	I	Global reset pin. Active low to enter reset state.	
6	STBYB	I	STBYB=1, normal operation. STBYB=0, timing control, source driver will turn off, all output are high-Z	
7	GND	P	Ground	
8	D0N	I/O	Positive MIPI differential data input	
9	D0P	I/O	Negative MIPI differential data input	
10	GND	P	Ground	
11	D1N	I/O	Positive MIPI differential data input	
12	D1P	I/O	Negative MIPI differential data input	
13	GND	P	Ground	
14	D2N	I/O	Positive MIPI differential data input	
15	D2P	I/O	Negative MIPI differential data input	
16	GND	P	Ground	
17	DCLKN	I/O	Positive MIPI differential clock input	
18	DCLKP	I/O	Negative MIPI differential clock input	
19	GND	P	Ground	
20	D3N	I/O	Positive MIPI differential data input	
21	D3P	I/O	Negative MIPI differential data input	
22	GND	P	Ground	
23	NC	-	No connection	
24	NC	-	No connection	
25	GND	P	Ground	
26	NC	-	No connection	
27	NC	-	No connection	
28	NC	-	No connection	
29	AVDD	P	Power for Analog Circuit	

30	GND	P	Ground	
31	LED-	P	LED Cathode	
32	LED-	P	LED Cathode	
33	L/R	I	Left/Right display control	Refer to 6.2
34	U/D	I	Up/Down display control	Refer to 6.2
35	VGL	P	Gate OFF Voltage	
36	NC	-	No connection	
37	NC	-	No connection	
38	VGH	P	Gate ON Voltage	
39	LED+	P	LED Anode	
40	LED+	P	LED Anode	

## 6.2 U/D R/L Function Description

Scan Control Input		Scanning Direction
UPDN	SHLR	
GND	VDD	Up to Down, Left to Right
VDD	GND	Down to Up, Right to Left
GND	GND	Up to Down, Right to Left
VDD	VDD	Down to Up, Left to Right

## 7. Timing Characteristics

### 7.1 Input Timing Table

DE mode

Parameter	Symbol	Value			Unit
		Min.	Typ.	Max.	
DCLK frequency @Frame rate=60hz	fclk	40.8	51.2	67.2	Mhz
Horizontal display area	thd	1024			DCLK
HSYNC period time	th	1114	1344	1400	DCLK
HSYNC blanking	thb+thfp	90	320	376	DCLK
Vertical display area	Tvd	600			H
VSYNC period time	Tv	610	635	800	H
VSYNC blanking	Tvb+Tvfp	10	35	200	H

HV mode

Horizontal input timing

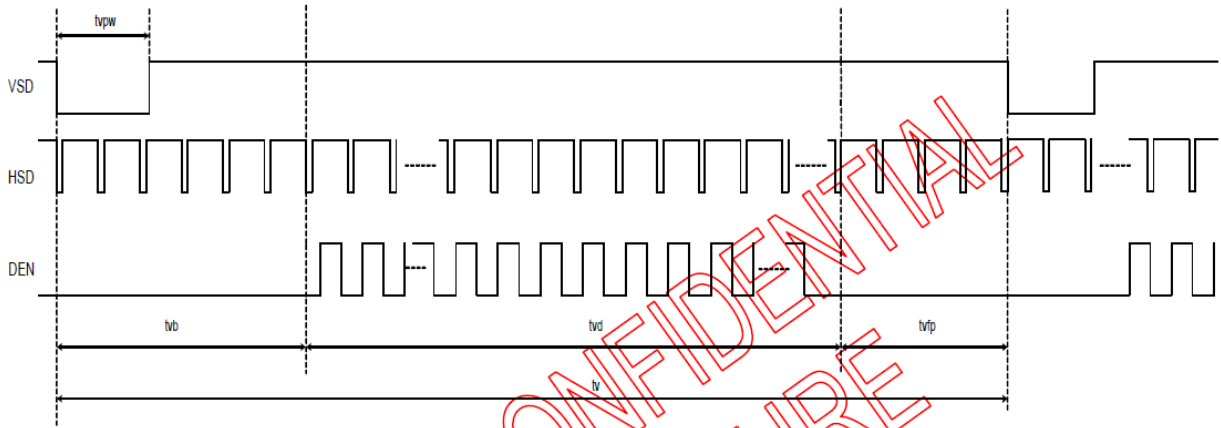
Parameter	Symbol	Value			Unit
Horizontal display area	thd	1024			DCLK
DCLK frequency@ Frame rate=60hz	fclk	Min. 44.9	Typ. 51.2	Max. 63	Mhz
1 Horizontal Line	th	1200	1344	1400	DCLK
HSYNC pulse width	thpw	Min.	1		
		Typ.	70		
		Max.	140		
HSYNC blanking	thb	160	160	160	
HSYNC front porch	thfp	16	160	216	

HV mode

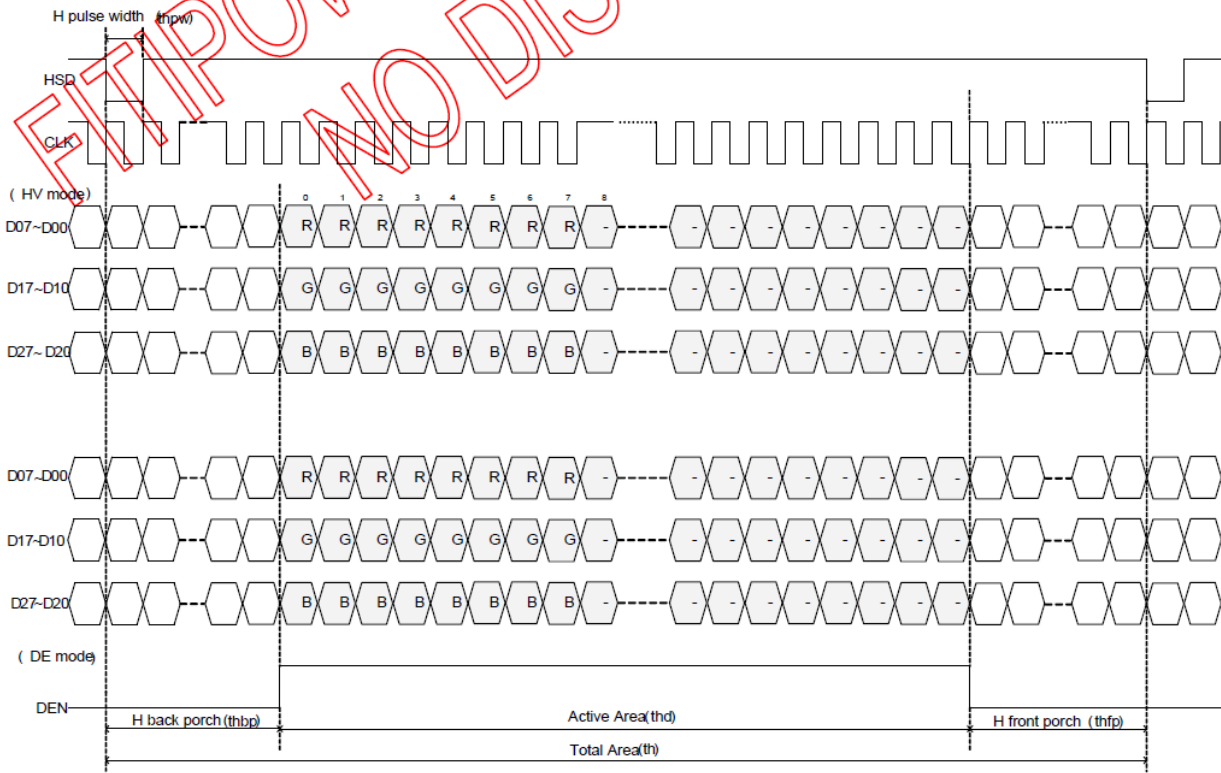
Vertical input timing

Parameter	Symbol	Value			Unit
		Min.	Typ.	Max.	
Vertical display area	tvd	600			H
VSYNC period time	tv	624	635	750	H
VSYNC pulse width	tvpw	1	10	20	H
VSYNC back porch	tvb	23	23	23	H
VSYNC front porch	tvfp	1	12	127	H

## 7.2 Input Timing



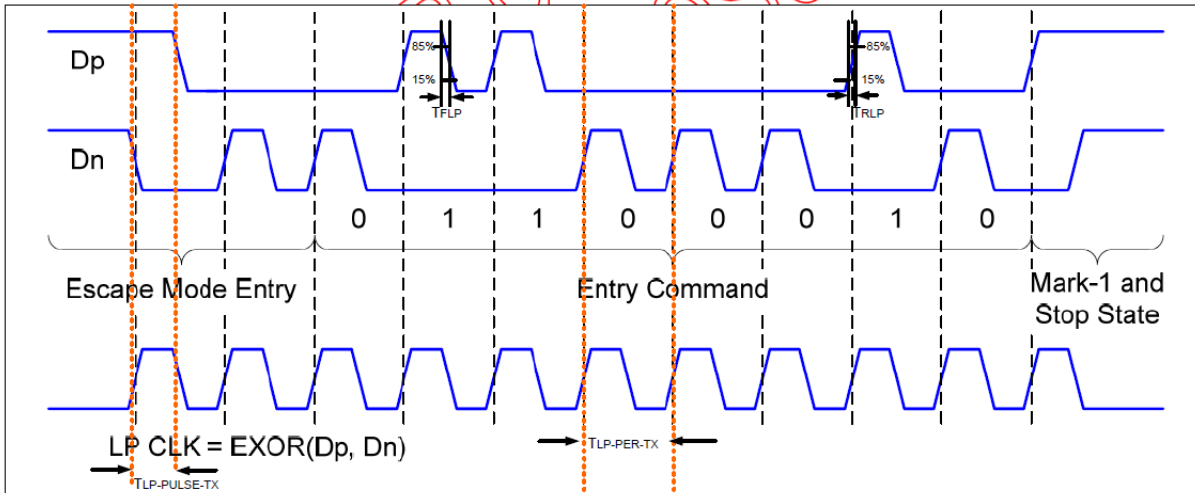
Vertical input timing



Horizontal input timing

## 7.3 LP Transmitter AC characteristic

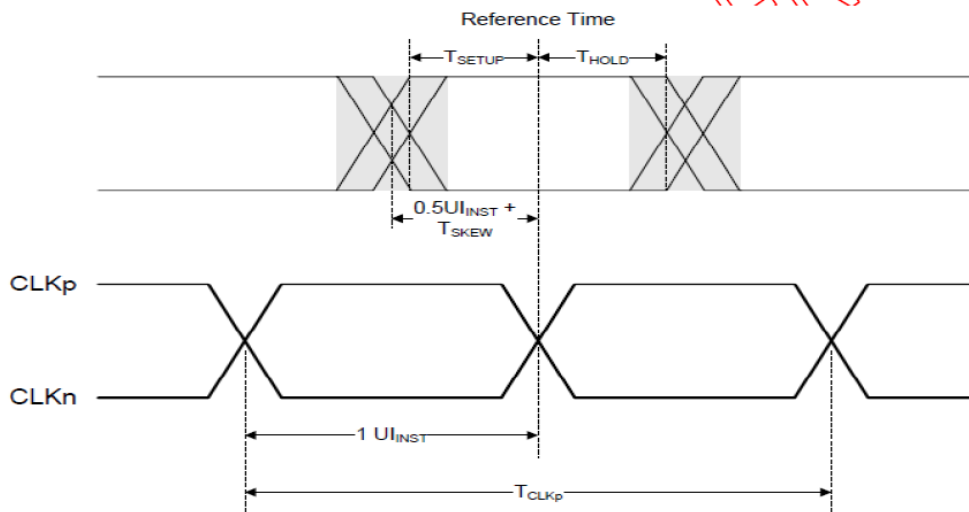
Parameter	Symbol	Min	Typ	Max	Units	Notes
15%~85% rising time and falling time	$T_{RLP} / T_{FLP}$	-	-	25	ns	-
30%~85% rising time and falling time	$T_{REOT}$	-	-	35	ns	-
Pulse width of LP exclusive-OR clock	First LP EXOR clock pulse after STOP state or Last pulse before stop state	40	-	-	ns	-
	All other pulses				ns	-
Period of the LP EXOR clock	$T_{LP-PER-TX}$	90	-	-	mV/ns	-
Slew Rate @CLOAD =0pF	$\delta V / \delta t_{SR}$	30	-	500	mV/ns	-
Slew Rate @CLOAD =5pF		30	-	200	mV/ns	-
Slew Rate @CLOAD =20pF		30	-	150	mV/ns	-
Slew Rate @CLOAD =70pF		30	-	100	mV/ns	-
Load Capacitance	$T_{RLP}$	-	-	70	pF	-





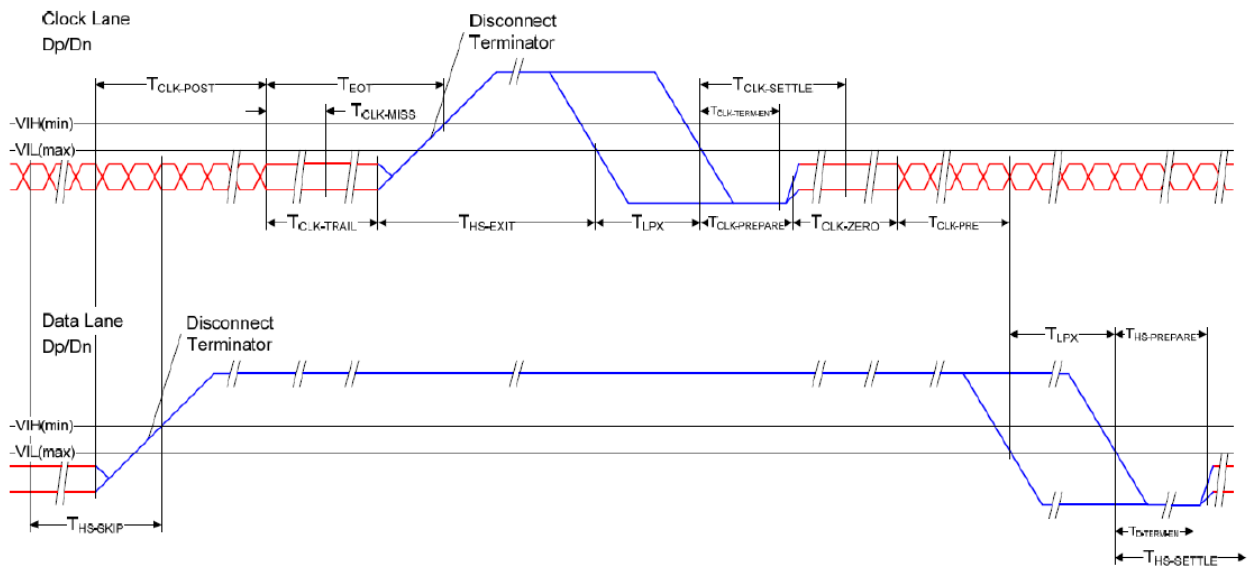
## 7.4 High speed transmission

Parameter	Symbol	Min	Typ	Max	Units
UI instantaneous	$UI_{INST}$	2	-	12.5	ns
Data to Clock Skew(measured at transmitter)	$T_{SKEW(TX)}$	-0.15	-	0.15	$UI_{INST}$
Data to Clock Setup time(measured at receiver)	$T_{SETUP(RX)}$	0.15	-	-	$UI_{INST}$
Data to Clock Hold time(measured at receiver)	$T_{HOLD(RX)}$	0.15	-	-	$UI_{INST}$
20%~80% rise time and fall time	$T_R, T_F$	150	-	-	ps
		-	-	0.3	$UI_{INST}$

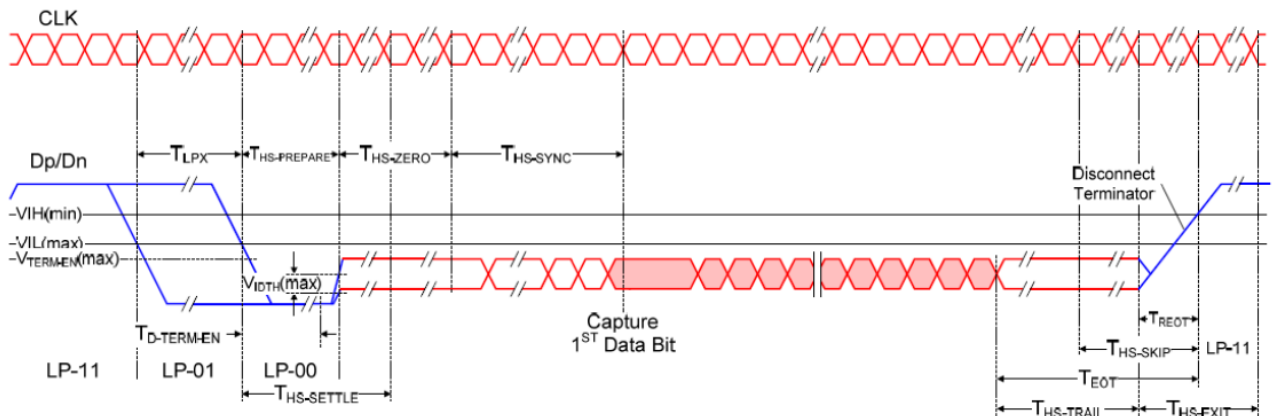


## 7.5 High speed clock transmission

Parameter	Symbol	Min	Typ	Max	Units
Time that the transmitter shall continue sending HS clock after the last associated Data Lane has transitioned to LP mode	TCLK-POST	60+52UI	-	-	ns
Detection time that the clock has stopped toggling	TCLK-MISS	-	-	60	ns
Time to drive LP-00 to prepare for HS clock transmission	TCLK-PREPARE	38	-	95	ns
Minimum lead HS-0 drive period before starting clock	TCLK-PREPARE + TCLK-ZERO	300	-	-	ns
Time to enable Clock Lane receiver line termination measured from when Dn cross $V_{IL,MAX}$	THS-TERM-EN	-	-	38	ns
Minimum time that the HS clock must be prior to any associated data lane beginning the transmission from LP to HS mode	TCLK-PRE	8	-	-	UI
Time to drive HS differential state after last payload clock bit of a HS transmission burst	TCLK-TRAIL	60	-	-	ns

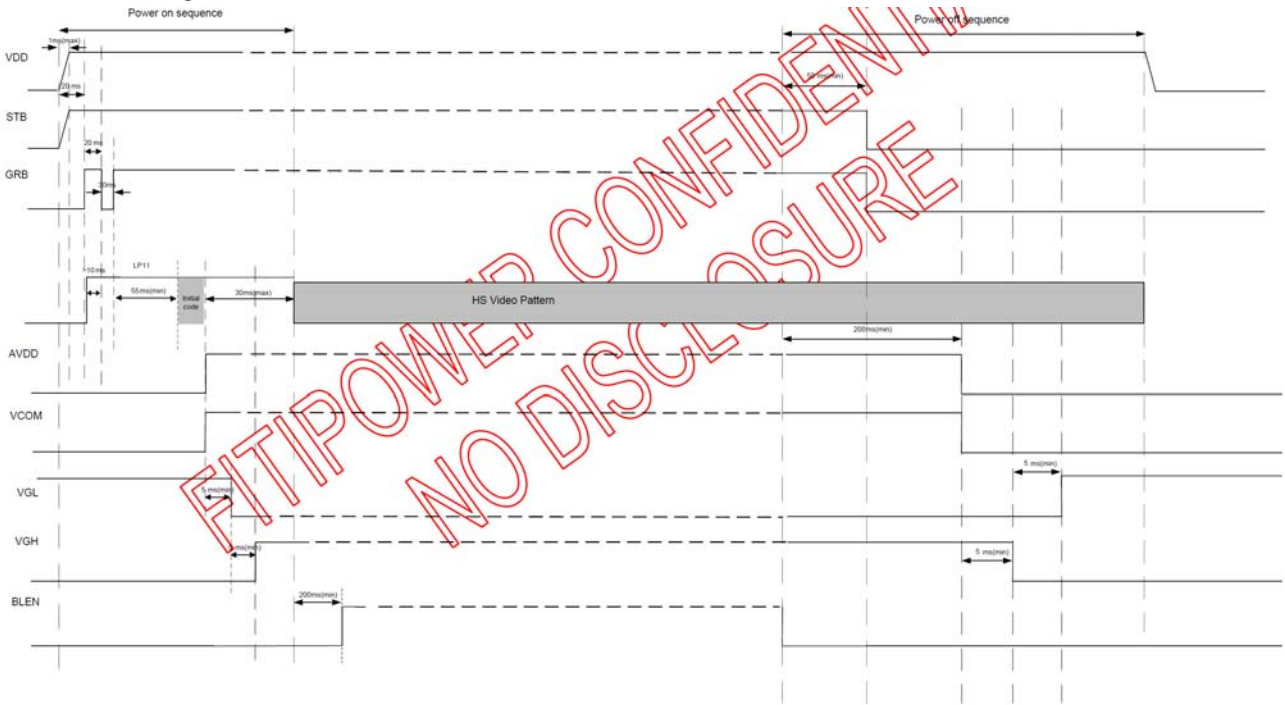


## 7.6 High speed data transmission in bursts



## 7.7 Power On/Off Sequence

In order to prevent IC from power on reset fail, the rising time (TPOR) of the digital power supply VDD should be maintained within the given specifications. Refer to “AC Characteristics” for more detail on timing.



Note: CLK and Data Lanes should keep in LP11(stop state) before GRB.

## 8. Outline Dimension

<table border="1" style="width: 100%; border-collapse: collapse;"> <tr><td>Display Type</td><td>Transmissive, Normally Black</td></tr> <tr><td>Display Resolution</td><td>1024(RGB)X600</td></tr> <tr><td>Viewing Angle</td><td>Free</td></tr> <tr><td>LCD Controller/Driver</td><td>/</td></tr> <tr><td>LCD Driving Voltage</td><td>3.3V</td></tr> <tr><td>Operation Temperature</td><td>-20°C TO 70°C</td></tr> <tr><td>Storage Temperature</td><td>-30°C TO 80°C</td></tr> <tr><td>Backlight Specialty</td><td>27PCS LEDs, Vf=9.6V, If=270mA</td></tr> <tr><td>Remark</td><td>All materials in the drawing comply with the ROHS</td></tr> </table>	Display Type	Transmissive, Normally Black	Display Resolution	1024(RGB)X600	Viewing Angle	Free	LCD Controller/Driver	/	LCD Driving Voltage	3.3V	Operation Temperature	-20°C TO 70°C	Storage Temperature	-30°C TO 80°C	Backlight Specialty	27PCS LEDs, Vf=9.6V, If=270mA	Remark	All materials in the drawing comply with the ROHS		
Display Type	Transmissive, Normally Black																			
Display Resolution	1024(RGB)X600																			
Viewing Angle	Free																			
LCD Controller/Driver	/																			
LCD Driving Voltage	3.3V																			
Operation Temperature	-20°C TO 70°C																			
Storage Temperature	-30°C TO 80°C																			
Backlight Specialty	27PCS LEDs, Vf=9.6V, If=270mA																			
Remark	All materials in the drawing comply with the ROHS																			

	<table border="1" style="width: 100%; border-collapse: collapse;"> <tr><th colspan="2">TFT ASSIGNMENT:</th></tr> <tr><td>PIN1</td><td>VCOM1</td></tr> <tr><td>2</td><td>VOD</td></tr> <tr><td>3</td><td>VOD</td></tr> <tr><td>4</td><td>NC</td></tr> <tr><td>5</td><td>NC</td></tr> <tr><td>6</td><td>RESET</td></tr> <tr><td>7</td><td>STBYB</td></tr> <tr><td>8</td><td>DDV</td></tr> <tr><td>9</td><td>DDP</td></tr> <tr><td>10</td><td>GND</td></tr> <tr><td>11</td><td>DDV</td></tr> <tr><td>12</td><td>DIP</td></tr> <tr><td>13</td><td>GND</td></tr> <tr><td>14</td><td>D2N</td></tr> <tr><td>15</td><td>D2P</td></tr> <tr><td>16</td><td>GND</td></tr> <tr><td>17</td><td>DCLKP</td></tr> <tr><td>18</td><td>DCLKP</td></tr> <tr><td>19</td><td>GND</td></tr> <tr><td>20</td><td>D2N</td></tr> <tr><td>21</td><td>D2P</td></tr> <tr><td>22</td><td>GND</td></tr> <tr><td>23</td><td>NC</td></tr> <tr><td>24</td><td>NC</td></tr> <tr><td>25</td><td>GND</td></tr> <tr><td>26</td><td>NC</td></tr> <tr><td>27</td><td>NC</td></tr> <tr><td>28</td><td>NC</td></tr> <tr><td>29</td><td>AVDD</td></tr> <tr><td>30</td><td>GND</td></tr> <tr><td>31</td><td>LED-</td></tr> <tr><td>32</td><td>LED-</td></tr> <tr><td>33</td><td>LNR</td></tr> <tr><td>34</td><td>LUD</td></tr> <tr><td>35</td><td>VGL</td></tr> <tr><td>36</td><td>NC</td></tr> <tr><td>37</td><td>NC</td></tr> <tr><td>38</td><td>VGH</td></tr> <tr><td>39</td><td>LED+</td></tr> <tr><td>40</td><td>LED+</td></tr> </table>	TFT ASSIGNMENT:		PIN1	VCOM1	2	VOD	3	VOD	4	NC	5	NC	6	RESET	7	STBYB	8	DDV	9	DDP	10	GND	11	DDV	12	DIP	13	GND	14	D2N	15	D2P	16	GND	17	DCLKP	18	DCLKP	19	GND	20	D2N	21	D2P	22	GND	23	NC	24	NC	25	GND	26	NC	27	NC	28	NC	29	AVDD	30	GND	31	LED-	32	LED-	33	LNR	34	LUD	35	VGL	36	NC	37	NC	38	VGH	39	LED+	40	LED+	
TFT ASSIGNMENT:																																																																																				
PIN1	VCOM1																																																																																			
2	VOD																																																																																			
3	VOD																																																																																			
4	NC																																																																																			
5	NC																																																																																			
6	RESET																																																																																			
7	STBYB																																																																																			
8	DDV																																																																																			
9	DDP																																																																																			
10	GND																																																																																			
11	DDV																																																																																			
12	DIP																																																																																			
13	GND																																																																																			
14	D2N																																																																																			
15	D2P																																																																																			
16	GND																																																																																			
17	DCLKP																																																																																			
18	DCLKP																																																																																			
19	GND																																																																																			
20	D2N																																																																																			
21	D2P																																																																																			
22	GND																																																																																			
23	NC																																																																																			
24	NC																																																																																			
25	GND																																																																																			
26	NC																																																																																			
27	NC																																																																																			
28	NC																																																																																			
29	AVDD																																																																																			
30	GND																																																																																			
31	LED-																																																																																			
32	LED-																																																																																			
33	LNR																																																																																			
34	LUD																																																																																			
35	VGL																																																																																			
36	NC																																																																																			
37	NC																																																																																			
38	VGH																																																																																			
39	LED+																																																																																			
40	LED+																																																																																			

	<table border="1" style="width: 100%; border-collapse: collapse;"> <tr><td>TITLE:</td><td>LCM Outline</td></tr> <tr><td>PROJECT NO.:</td><td>RK070CU05H</td></tr> <tr><td>DESCRIPTION:</td><td>7.0 Inch TFT with high luminance with mipi interface</td></tr> <tr><td>GENERAL TOLERANCE:</td><td>±0.2</td></tr> </table>	TITLE:	LCM Outline	PROJECT NO.:	RK070CU05H	DESCRIPTION:	7.0 Inch TFT with high luminance with mipi interface	GENERAL TOLERANCE:	±0.2	
TITLE:	LCM Outline									
PROJECT NO.:	RK070CU05H									
DESCRIPTION:	7.0 Inch TFT with high luminance with mipi interface									
GENERAL TOLERANCE:	±0.2									

	<table border="1" style="width: 100%; border-collapse: collapse;"> <tr> <th>NAME</th> <th>SIGN</th> <th>DATE</th> </tr> <tr> <td>DRAWN</td> <td>Marvin Zhou</td> <td>2019.08.22</td> </tr> <tr> <td>CHECKED</td> <td>Marvin Zhou</td> <td>2019.08.22</td> </tr> <tr> <td>REV. 1.0</td> <td>UNIT: MM</td> <td>SCALE: 1/1</td> </tr> <tr> <td></td> <td></td> <td>SHEET: 1 OF 1</td> </tr> </table>	NAME	SIGN	DATE	DRAWN	Marvin Zhou	2019.08.22	CHECKED	Marvin Zhou	2019.08.22	REV. 1.0	UNIT: MM	SCALE: 1/1			SHEET: 1 OF 1	
NAME	SIGN	DATE															
DRAWN	Marvin Zhou	2019.08.22															
CHECKED	Marvin Zhou	2019.08.22															
REV. 1.0	UNIT: MM	SCALE: 1/1															
		SHEET: 1 OF 1															

ISSUE	MODIFY DESCRIPTION	DATE
1.0	First Issue	2019.08.22

## 9. Reliability and Inspection Standard

No.	Test Item	Test Conditions	Remark	
1	High Temperature	Storage	80°C, 120Hr	Note
		Operation	70°C, 120Hr	Note
2	Low Temperature	Storage	-30°C, 120Hr	Note
		Operation	-20°C, 120Hr	
3	High Temperature and High Humidity	40°C, 90%RH, 120Hr	Note	
4	Thermal Cycling Test(No operation)	-20°C for 30min, 70°C for 30 min. 100 cycles. Then test at room temperature after 1 hour	Note	
5	Vibration Test(No operation)	Frequency :10~55 HZ; Stroke :1.5 mm;Sweep:10HZ~55HZ~10HZ; 2hours for each direction of X, Y, Z(6 hours for total)		
6	Package Drop Test	Height:60 cm,1 corner, 3 edges, 6 surfaces		
7	Electro Static Discharge	±2KV,Human Body Mode, 100pF/1500Ω		

Note:

- 1) Sample quantity for each test item is 5~10pcs.
- 2) Note 4: Before cosmetic and function test, the product must have enough recovery time, at least 2 hours at room temperature.

## 10. PRECAUTIONS FOR USING LCD MODULES

### Handling Precautions

- (1) The display panel is made of glass and polarizer. As glass is fragile, it tends to become or chipped during handling especially on the edges. Please avoid dropping or jarring. Do not subject it to a mechanical shock by dropping it or impact.
- (2) If the display panel is damaged and the liquid crystal substance leaks out, be sure not to get any in your mouth. If the substance contacts your skin or clothes, wash it off using soap and water.
- (3) Do not apply excessive force to the display surface or the adjoining areas since this may cause the color tone to vary. Do not touch the display with bare hands. This will stain the display area and degraded insulation between terminals (some cosmetics are determined to the polarizer).
- (4) The polarizer covering the display surface of the LCD module is soft and easily scratched. Handle this polarizer carefully. Do not touch, push or rub the exposed polarizers with anything harder than an HB pencil lead (glass, tweezers, etc.). Do not put or attach anything on the display area to avoid leaving marks on. Condensation on the surface and contact with terminals due to cold will damage, stain or dirty the polarizer. After products are tested at low temperature they must be warmed up in a container before coming in contact with room temperature air.
- (5) If the display surface becomes contaminated, breathe on the surface and gently wipe it with a soft dry cloth. If it is heavily contaminated, moisten cloth with one of the following solvents
  - Isopropyl alcohol
  - Ethyl alcoholDo not scrub hard to avoid damaging the display surface.
- (6) Solvents other than those above-mentioned may damage the polarizer. Especially, do not use the following.
  - Water
  - Ketone
  - Aromatic solventsWipe off saliva or water drops immediately, contact with water over a long period of time may cause deformation or color fading. Avoid contacting oil and fats.
- (7) Exercise care to minimize corrosion of the electrode. Corrosion of the electrodes is accelerated by water droplets, moisture condensation or a current flow in a high-humidity environment.
- (8) Install the LCD Module by using the mounting holes. When mounting the LCD module make sure it is free of twisting, warping and distortion. In particular, do not forcibly pull or bend the I/O cable or the backlight cable.
- (9) Do not attempt to disassemble or process the LCD module.
- (10) NC terminal should be open. Do not connect anything.
- (11) If the logic circuit power is off, do not apply the input signals.
- (12) Since LCM has been assembled and adjusted with a high degree of precision, avoid applying excessive shocks to the module or making any alterations or modifications to it.
  - Do not alter, modify or change the shape of the tab on the metal frame.
  - Do not make extra holes on the printed circuit board, modify its shape or change the positions of components to be attached.
  - Do not damage or modify the pattern writing on the printed circuit board.
  - Absolutely do not modify the zebra rubber strip (conductive rubber) or heat seal

connector.

- Except for soldering the interface, do not make any alterations or modifications with a soldering iron.
- Do not drop, bend or twist LCM.

## Storage Precautions

When storing the LCD modules, the following precaution is necessary.

- (1) Store them in a sealed polyethylene bag. If properly sealed, there is no need for the dessicant.
- (2) Store them in a dark place. Do not expose to sunlight or fluorescent light, keep the temperature between 0°C and 35°C.
- (3) The polarizer surface should not come in contact with any other objects. (We advise you to store them in the container in which they were shipped).

## Others

Liquid crystals solidify under low temperature (below the storage temperature range) leading to defective orientation or the generation of air bubbles (black or white). Air bubbles may also be generated if the module is subject to a low temperature.

If the LCD modules have been operating for a long time showing the same display patterns, the display patterns may remain on the screen as ghost images and a slight contrast irregularity may also appear. A normal operating status can be regained by suspending use for some time. It should be noted that this phenomenon does not adversely affect performance reliability.

To minimize the performance degradation of the LCD modules resulting from destruction caused by static electricity etc., exercise care to avoid holding the following sections when handling the modules.

- Exposed area of the printed circuit board.
- Terminal electrode sections.