

DDR2 Memory

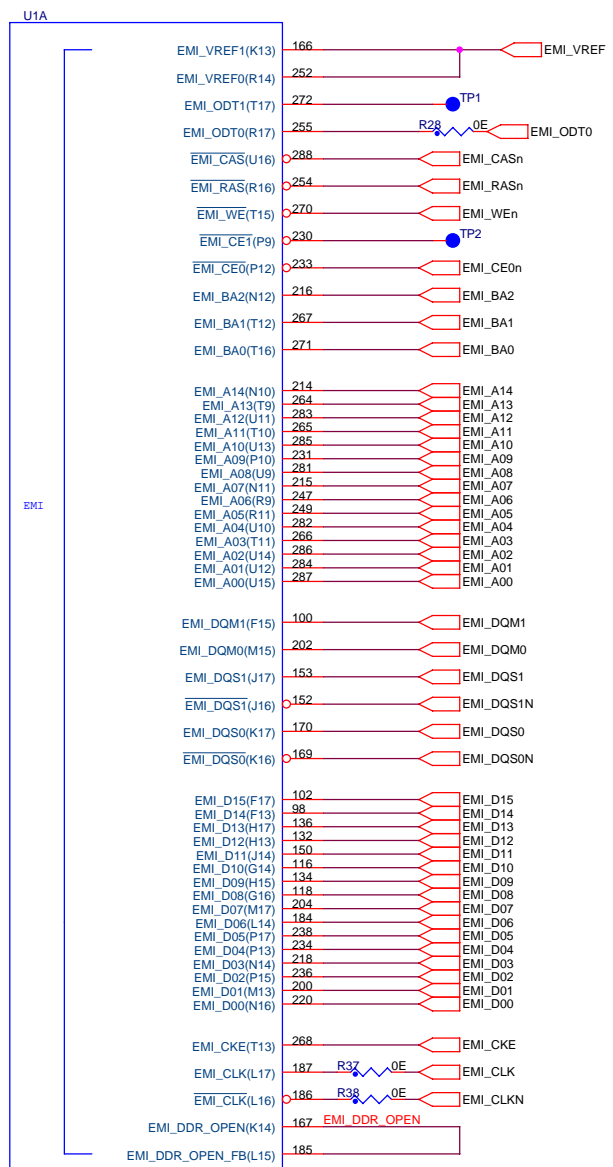

Short to match trace length to CLK+DATA signals

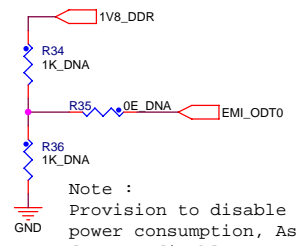
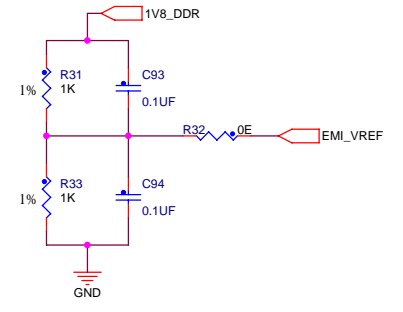
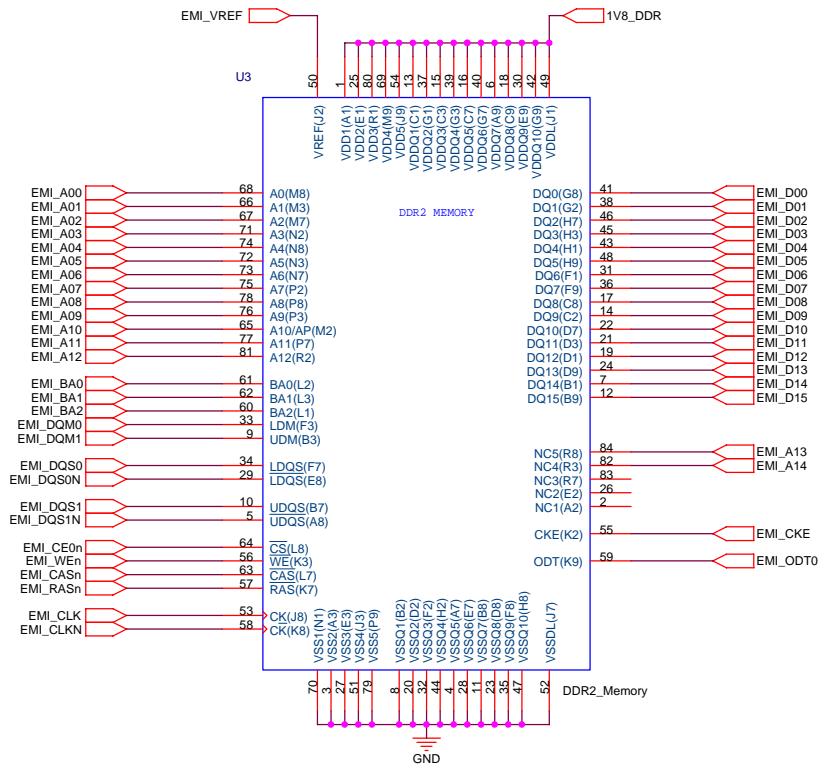
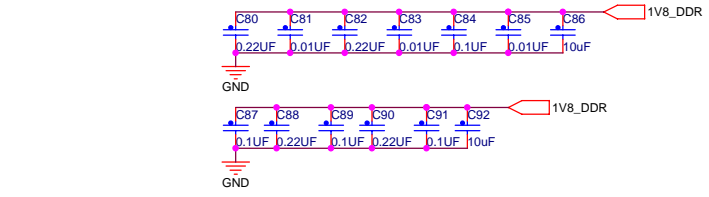

Note : Provision to disable ODT to reduce power consumption, Assemble pull down to disable ODT