



# ST24C08, ST25C08 ST24W08, ST25W08

## 8 Kbit Serial I<sup>2</sup>C Bus EEPROM with User-Defined Block Write Protection

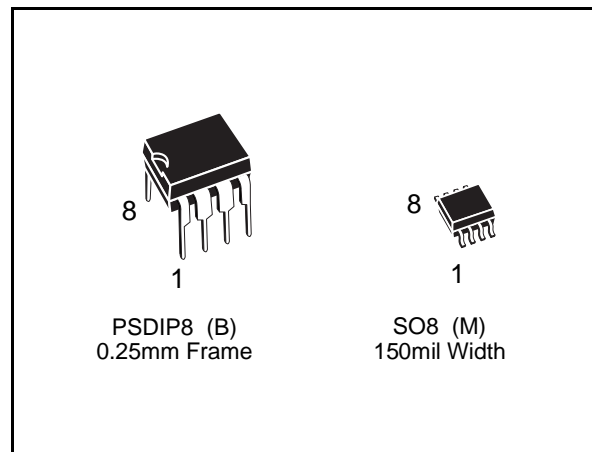
- 1 MILLION ERASE/WRITE CYCLES with 40 YEARS DATA RETENTION
- SINGLE SUPPLY VOLTAGE:
  - 3V to 5.5V for ST24x08 versions
  - 2.5V to 5.5V for ST25x08 versions
- HARDWARE WRITE CONTROL VERSIONS: ST24W08 and ST25W08
- PROGRAMMABLE WRITE PROTECTION
- TWO WIRE SERIAL INTERFACE, FULLY I<sup>2</sup>C BUS COMPATIBLE
- BYTE and MULTIBYTE WRITE (up to 8 BYTES)
- PAGE WRITE (up to 16 BYTES)
- BYTE, RANDOM and SEQUENTIAL READ MODES
- SELF TIMED PROGRAMMING CYCLE
- AUTOMATIC ADDRESS INCREMENTING
- ENHANCED ESD/LATCH UP PERFORMANCES

### DESCRIPTION

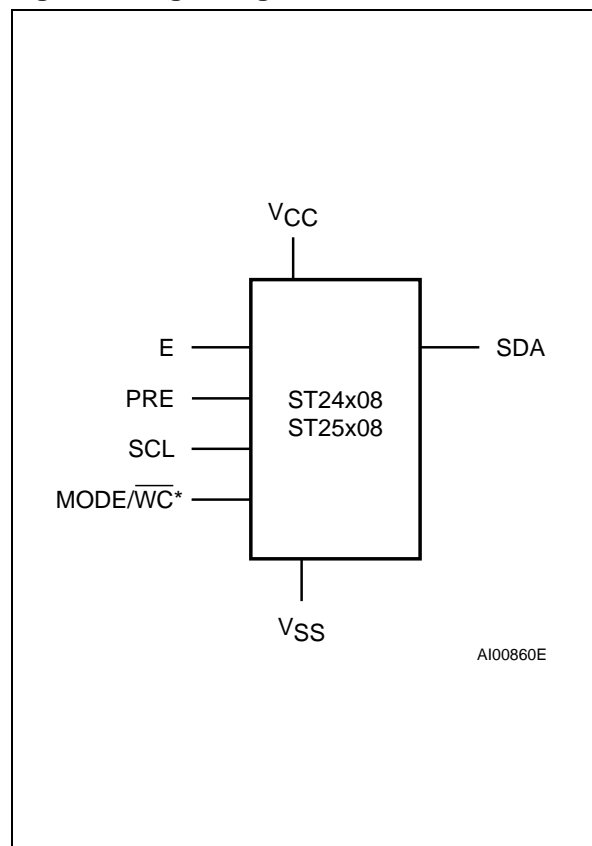
This specification covers a range of 8 Kbits I<sup>2</sup>C bus EEPROM products, the ST24/25C08 and the ST24/25W08. In the text, products are referred to as ST24/25x08, where "x" is: "C" for Standard version and "W" for Hardware Write Control version.

**Table 1. Signal Names**

PRE	Write Protect Enable
E	Chip Enable Input
SDA	Serial Data Address Input/Output
SCL	Serial Clock
MODE	Multibyte/Page Write Mode (C version)
$\overline{WC}$	Write Control (W version)
V <sub>CC</sub>	Supply Voltage
V <sub>SS</sub>	Ground

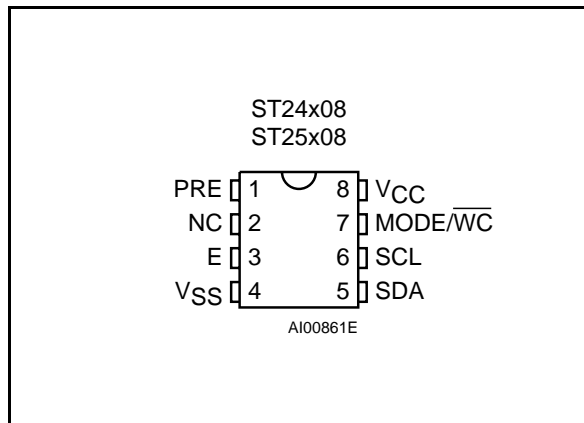


**Figure 1. Logic Diagram**



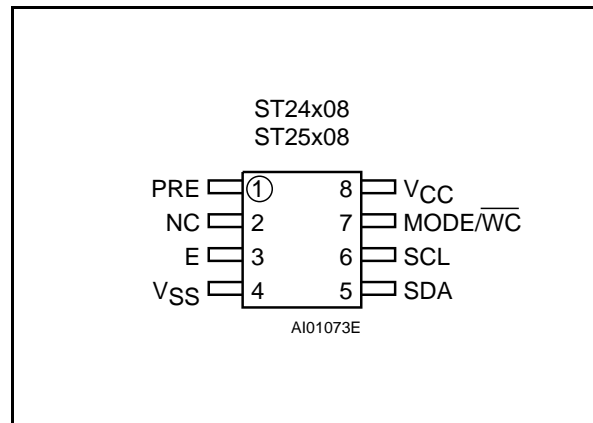
**Note:**  $\overline{WC}$  signal is only available for ST24/25W08 products.

Figure 2A. DIP Pin Connections



Warning: NC = Not Connected.

Figure 2B. SO Pin Connections



Warning: NC = Not Connected.

Table 2. Absolute Maximum Ratings <sup>(1)</sup>

Symbol	Parameter	Value	Unit
T <sub>A</sub>	Ambient Operating Temperature	-40 to 125	°C
T <sub>STG</sub>	Storage Temperature	-65 to 150	°C
T <sub>LEAD</sub>	Lead Temperature, Soldering (SO8 package) 40 sec (PSDIP8 package) 10 sec	215 260	°C
V <sub>IO</sub>	Input or Output Voltages	-0.6 to 6.5	V
V <sub>CC</sub>	Supply Voltage	-0.3 to 6.5	V
V <sub>ESD</sub>	Electrostatic Discharge Voltage (Human Body model) <sup>(2)</sup>	4000	V
	Electrostatic Discharge Voltage (Machine model) <sup>(3)</sup>	500	V

Notes: 1. Except for the rating "Operating Temperature Range", stresses above those listed in the Table "Absolute Maximum Ratings" may cause permanent damage to the device. These are stress ratings only and operation of the device at these or any other conditions above those indicated in the Operating sections of this specification is not implied. Exposure to Absolute Maximum Rating conditions for extended periods may affect device reliability. Refer also to the STMicroelectronics SURE Program and other relevant quality documents.

2. MIL-STD-883C, 3015.7 (100pF, 1500 Ω).

3. EIAJ IC-121 (Condition C) (200pF, 0 Ω).

**DESCRIPTION** (cont'd)

The ST24/25x08 are 8 Kbit electrically erasable programmable memories (EEPROM), organized as 4 blocks of 256 x8 bits. They are manufactured in STMicroelectronics's Hi-Endurance Advanced CMOS technology which guarantees an endurance of one million erase/write cycles with a data retention of 40 years.

Both Plastic Dual-in-Line and Plastic Small Outline packages are available.

The memories are compatible with the I<sup>2</sup>C standard, two wire serial interface which uses a bi-direc-

tional data bus and serial clock. The memories carry a built-in 4 bit, unique device identification code (1010) corresponding to the I<sup>2</sup>C bus definition. This is used together with 1 chip enable input (E) so that up to 2 x 8K devices may be attached to the I<sup>2</sup>C bus and selected individually. The memories behave as a slave device in the I<sup>2</sup>C protocol with all memory operations synchronized by the serial clock. Read and write operations are initiated by a START condition generated by the bus master. The START condition is followed by a stream of 7 bits (identification code 1010), plus one read/write bit and terminated by an acknowledge bit.

Table 3. Device Select Code

Bit	Device Code				Chip Enable	Block Select		R $\bar{W}$
	b7	b6	b5	b4	b3	b2	b1	b0
Device Select	1	0	1	0	E	A9	A8	R $\bar{W}$

Note: The MSB b7 is sent first.

Table 4. Operating Modes <sup>(1)</sup>

Mode	R $\bar{W}$ bit	MODE	Bytes	Initial Sequence
Current Address Read	'1'	X	1	START, Device Select, R $\bar{W}$ = '1'
Random Address Read	'0'	X	1	START, Device Select, R $\bar{W}$ = '0', Address,
	'1'			reSTART, Device Select, R $\bar{W}$ = '1'
Sequential Read	'1'	X	1 to 1024	Similar to Current or Random Mode
Byte Write	'0'	X	1	START, Device Select, R $\bar{W}$ = '0'
Multibyte Write <sup>(2)</sup>	'0'	V <sub>IH</sub>	8	START, Device Select, R $\bar{W}$ = '0'
Page Write	'0'	V <sub>IL</sub>	16	START, Device Select, R $\bar{W}$ = '0'

Notes: 1. X = V<sub>IH</sub> or V<sub>IL</sub>.

2. Multibyte Write not available in ST24/25W08 versions.

When writing data to the memory it responds to the 8 bits received by asserting an acknowledge bit during the 9th bit time. When data is read by the bus master, it acknowledges the receipt of the data bytes in the same way. Data transfers are terminated with a STOP condition.

**Power On Reset: V<sub>CC</sub> lock out write protect.** In order to prevent data corruption and inadvertent write operations during power up, a Power On Reset (POR) circuit is implemented. Until the V<sub>CC</sub> voltage has reached the POR threshold value, the internal reset is active, all operations are disabled and the device will not respond to any command. In the same way, when V<sub>CC</sub> drops down from the operating voltage to below the POR threshold value, all operations are disabled and the device will not respond to any command. A stable V<sub>CC</sub> must be applied before applying any logic signal.

## SIGNAL DESCRIPTIONS

**Serial Clock (SCL).** The SCL input pin is used to synchronize all data in and out of the memory. A resistor can be connected from the SCL line to V<sub>CC</sub> to act as a pull up (see Figure 3).

**Serial Data (SDA).** The SDA pin is bi-directional and is used to transfer data in or out of the memory. It is an open drain output that may be wire-OR'ed

with other open drain or open collector signals on the bus. A resistor must be connected from the SDA bus line to V<sub>CC</sub> to act as pull up (see Figure 3).

**Chip Enable (E).** This chip enable input is used to set one least significant bit (b3) of the device select byte code. This input may be driven dynamically or tied to V<sub>CC</sub> or V<sub>SS</sub> to establish the device select code.

**Protect Enable (PRE).** The PRE input pin, in addition to the status of the Block Address Pointer bit (b2, location 3FFh as in Figure 7), sets the PRE write protection active.

**Mode (MODE).** The MODE input is available on pin 7 (see also  $\bar{W}C$  feature) and may be driven dynamically. It must be at V<sub>IL</sub> or V<sub>IH</sub> for the Byte Write mode, V<sub>IH</sub> for Multibyte Write mode or V<sub>IL</sub> for Page Write mode. When unconnected, the MODE input is internally read as a V<sub>IH</sub> (Multibyte Write mode).

**Write Control ( $\bar{W}C$ ).** An hardware Write Control ( $\bar{W}C$ ) feature is offered only for ST24W08 and ST25W08 versions on pin 7. This feature is useful to protect the contents of the memory from any erroneous erase/write cycle. The Write Control signal is used to enable ( $\bar{W}C = V_{IH}$ ) or disable ( $\bar{W}C = V_{IL}$ ) the internal write protection. When unconnected, the  $\bar{W}C$  input is internally read as V<sub>IL</sub> and the memory area is not write protected.

**SIGNAL DESCRIPTIONS** (cont'd)

The devices with this Write Control feature no longer support the Multibyte Write mode of operation, however all other write modes are fully supported.

Refer to the AN404 Application Note for more detailed information about Write Control feature.

**DEVICE OPERATION**

**I<sup>2</sup>C Bus Background**

The ST24/25x08 support the I<sup>2</sup>C protocol. This protocol defines any device that sends data onto the bus as a transmitter and any device that reads the data as a receiver. The device that controls the data transfer is known as the master and the other as the slave. The master will always initiate a data transfer and will provide the serial clock for synchronisation. The ST24/25x08 are always slave devices in all communications.

**Start Condition.** START is identified by a high to low transition of the SDA line while the clock SCL is stable in the high state. A START condition must precede any command for data transfer. Except during a programming cycle, the ST24/25x08 continuously monitor the SDA and SCL signals for a START condition and will not respond unless one is given.

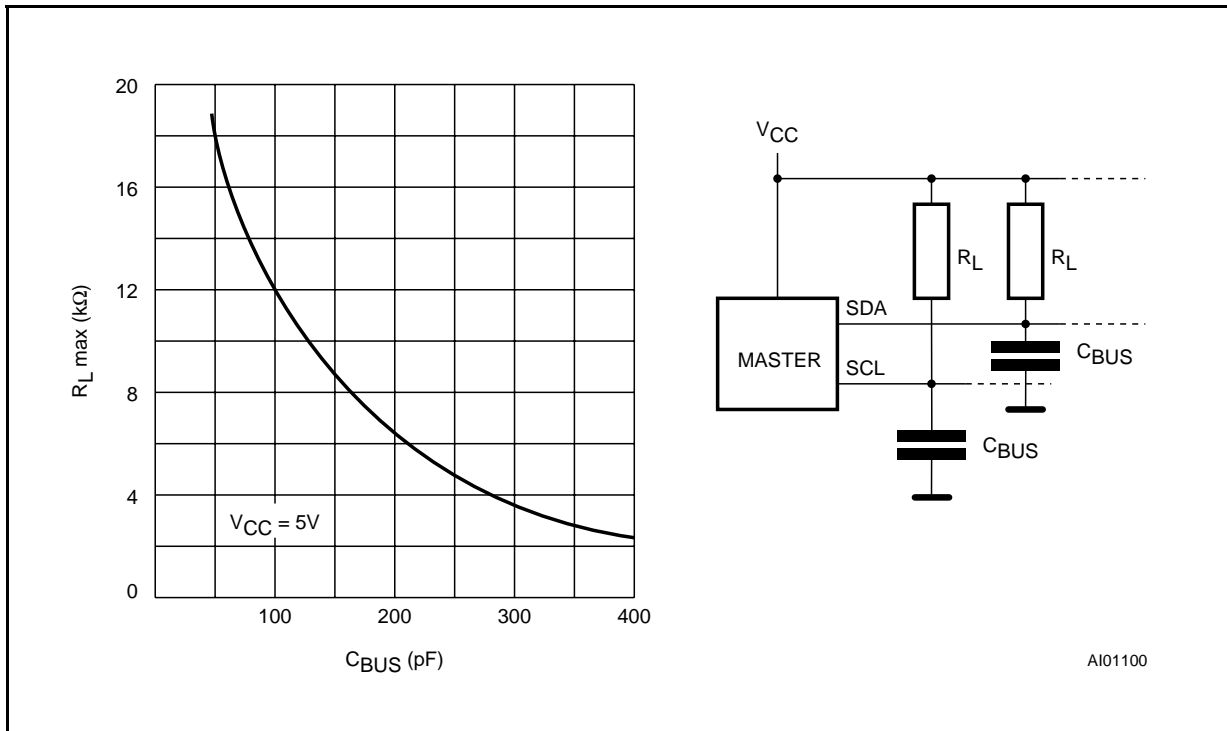
**Stop Condition.** STOP is identified by a low to high transition of the SDA line while the clock SCL is stable in the high state. A STOP condition terminates communication between the ST24/25x08 and the bus master. A STOP condition at the end of a Read command, after and only after a No Acknowledge, forces the standby state. A STOP condition at the end of a Write command triggers the internal EEPROM write cycle.

**Acknowledge Bit (ACK).** An acknowledge signal is used to indicate a successful data transfer. The bus transmitter, either master or slave, will release the SDA bus after sending 8 bits of data. During the 9th clock pulse period the receiver pulls the SDA bus low to acknowledge the receipt of the 8 bits of data.

**Data Input.** During data input the ST24/25x08 sample the SDA bus signal on the rising edge of the clock SCL. Note that for correct device operation the SDA signal must be stable during the clock low to high transition and the data must change ONLY when the SCL line is low.

**Memory Addressing.** To start communication between the bus master and the slave ST24/25x08, the master must initiate a START condition. Following this, the master sends onto the SDA bus line 8 bits (MSB first) corresponding to the device select code (7 bits) and a READ or WRITE bit.

**Figure 3. Maximum R<sub>L</sub> Value versus Bus Capacitance (C<sub>BUS</sub>) for an I<sup>2</sup>C Bus**



**Table 5. Input Parameters** <sup>(1)</sup> ( $T_A = 25\text{ }^\circ\text{C}$ ,  $f = 100\text{ kHz}$ )

Symbol	Parameter	Test Condition	Min	Max	Unit
$C_{IN}$	Input Capacitance (SDA)			8	pF
$C_{IN}$	Input Capacitance (other pins)			6	pF
$Z_{WCL}$	$\overline{WC}$ Input Impedance (ST24/25W08)	$V_{IN} \leq 0.3 V_{CC}$	5	20	k $\Omega$
$Z_{WCH}$	$\overline{WC}$ Input Impedance (ST24/25W08)	$V_{IN} \geq 0.7 V_{CC}$	500		k $\Omega$
$t_{LP}$	Low-pass filter input time constant (SDA and SCL)			100	ns

**Note:** 1. Sampled only, not 100% tested.

**Table 6. DC Characteristics**

( $T_A = 0$  to  $70\text{ }^\circ\text{C}$ ,  $-20$  to  $85\text{ }^\circ\text{C}$  or  $-40$  to  $85\text{ }^\circ\text{C}$ ;  $V_{CC} = 3\text{V}$  to  $5.5\text{V}$  or  $2.5\text{V}$  to  $5.5\text{V}$ )

Symbol	Parameter	Test Condition	Min	Max	Unit
$I_{LI}$	Input Leakage Current	$0\text{V} \leq V_{IN} \leq V_{CC}$		$\pm 2$	$\mu\text{A}$
$I_{LO}$	Output Leakage Current	$0\text{V} \leq V_{OUT} \leq V_{CC}$ SDA in Hi-Z		$\pm 2$	$\mu\text{A}$
$I_{CC}$	Supply Current (ST24 series)	$V_{CC} = 5\text{V}$ , $f_C = 100\text{kHz}$ (Rise/Fall time < 10ns)		2	mA
	Supply Current (ST25 series)	$V_{CC} = 2.5\text{V}$ , $f_C = 100\text{kHz}$		1	mA
$I_{CC1}$	Supply Current (Standby) (ST24 series)	$V_{IN} = V_{SS}$ or $V_{CC}$ , $V_{CC} = 5\text{V}$		100	$\mu\text{A}$
		$V_{IN} = V_{SS}$ or $V_{CC}$ , $V_{CC} = 5\text{V}$ , $f_C = 100\text{kHz}$		300	$\mu\text{A}$
$I_{CC2}$	Supply Current (Standby) (ST25 series)	$V_{IN} = V_{SS}$ or $V_{CC}$ , $V_{CC} = 2.5\text{V}$		5	$\mu\text{A}$
		$V_{IN} = V_{SS}$ or $V_{CC}$ , $V_{CC} = 2.5\text{V}$ , $f_C = 100\text{kHz}$		50	$\mu\text{A}$
$V_{IL}$	Input Low Voltage (SCL, SDA)		-0.3	$0.3 V_{CC}$	V
$V_{IH}$	Input High Voltage (SCL, SDA)		$0.7 V_{CC}$	$V_{CC} + 1$	V
$V_{IL}$	Input Low Voltage____ (E, PRE, MODE, WC)		-0.3	0.5	V
$V_{IH}$	Input High Voltage____ (E, PRE, MODE, WC)		$V_{CC} - 0.5$	$V_{CC} + 1$	V
$V_{OL}$	Output Low Voltage (ST24 series)	$I_{OL} = 3\text{mA}$ , $V_{CC} = 5\text{V}$		0.4	V
	Output Low Voltage (ST25 series)	$I_{OL} = 2.1\text{mA}$ , $V_{CC} = 2.5\text{V}$		0.4	V

**Table 7. AC Characteristics**

( $T_A = 0$  to  $70^\circ\text{C}$ ,  $-20$  to  $85^\circ\text{C}$  or  $-40$  to  $85^\circ\text{C}$ ;  $V_{CC} = 3\text{V}$  to  $5.5\text{V}$  or  $2.5\text{V}$  to  $5.5\text{V}$ )

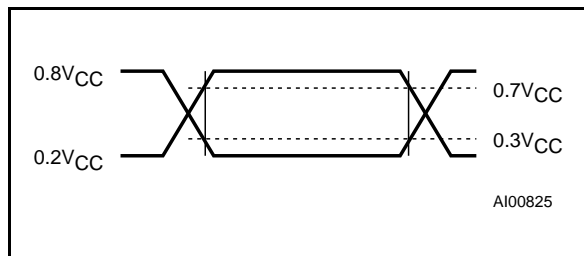
Symbol	Alt	Parameter	Min	Max	Unit
$t_{CH1CH2}$	$t_R$	Clock Rise Time		1	$\mu\text{s}$
$t_{CL1CL2}$	$t_F$	Clock Fall Time		300	ns
$t_{DH1DH2}$	$t_R$	Input Rise Time		1	$\mu\text{s}$
$t_{DL1DL1}$	$t_F$	Input Fall Time		300	ns
$t_{CHDX}^{(1)}$	$t_{SU:STA}$	Clock High to Input Transition	4.7		$\mu\text{s}$
$t_{CHCL}$	$t_{HIGH}$	Clock Pulse Width High	4		$\mu\text{s}$
$t_{DLCL}$	$t_{HD:STA}$	Input Low to Clock Low (START)	4		$\mu\text{s}$
$t_{CLDX}$	$t_{HD:DAT}$	Clock Low to Input Transition	0		$\mu\text{s}$
$t_{CLCH}$	$t_{LOW}$	Clock Pulse Width Low	4.7		$\mu\text{s}$
$t_{DXCX}$	$t_{SU:DAT}$	Input Transition to Clock Transition	250		ns
$t_{CHDH}$	$t_{SU:STO}$	Clock High to Input High (STOP)	4.7		$\mu\text{s}$
$t_{DHDL}$	$t_{BUF}$	Input High to Input Low (Bus Free)	4.7		$\mu\text{s}$
$t_{CLQV}^{(2)}$	$t_{AA}$	Clock Low to Next Data Out Valid	0.3	3.5	$\mu\text{s}$
$t_{CLQX}$	$t_{DH}$	Data Out Hold Time	300		ns
$f_C$	$f_{SCL}$	Clock Frequency		100	kHz
$t_W^{(3)}$	$t_{WR}$	Write Time		10	ms

- Notes:** 1. For a reSTART condition, or following a write cycle.  
 2. The minimum value delays the falling/rising edge of SDA away from SCL = 1 in order to avoid unwanted START and/or STOP conditions.  
 3. In the Multibyte Write mode only, if accessed bytes are on two consecutive 8 bytes rows (6 address MSB are not constant) the maximum programming time is doubled to 20ms.

**Table 8. AC Measurement Conditions**

Input Rise and Fall Times	$\leq 50\text{ns}$
Input Pulse Voltages	$0.2V_{CC}$ to $0.8V_{CC}$
Input and Output Timing Ref. Voltages	$0.3V_{CC}$ to $0.7V_{CC}$

**Figure 4. AC Testing Input Output Waveforms**

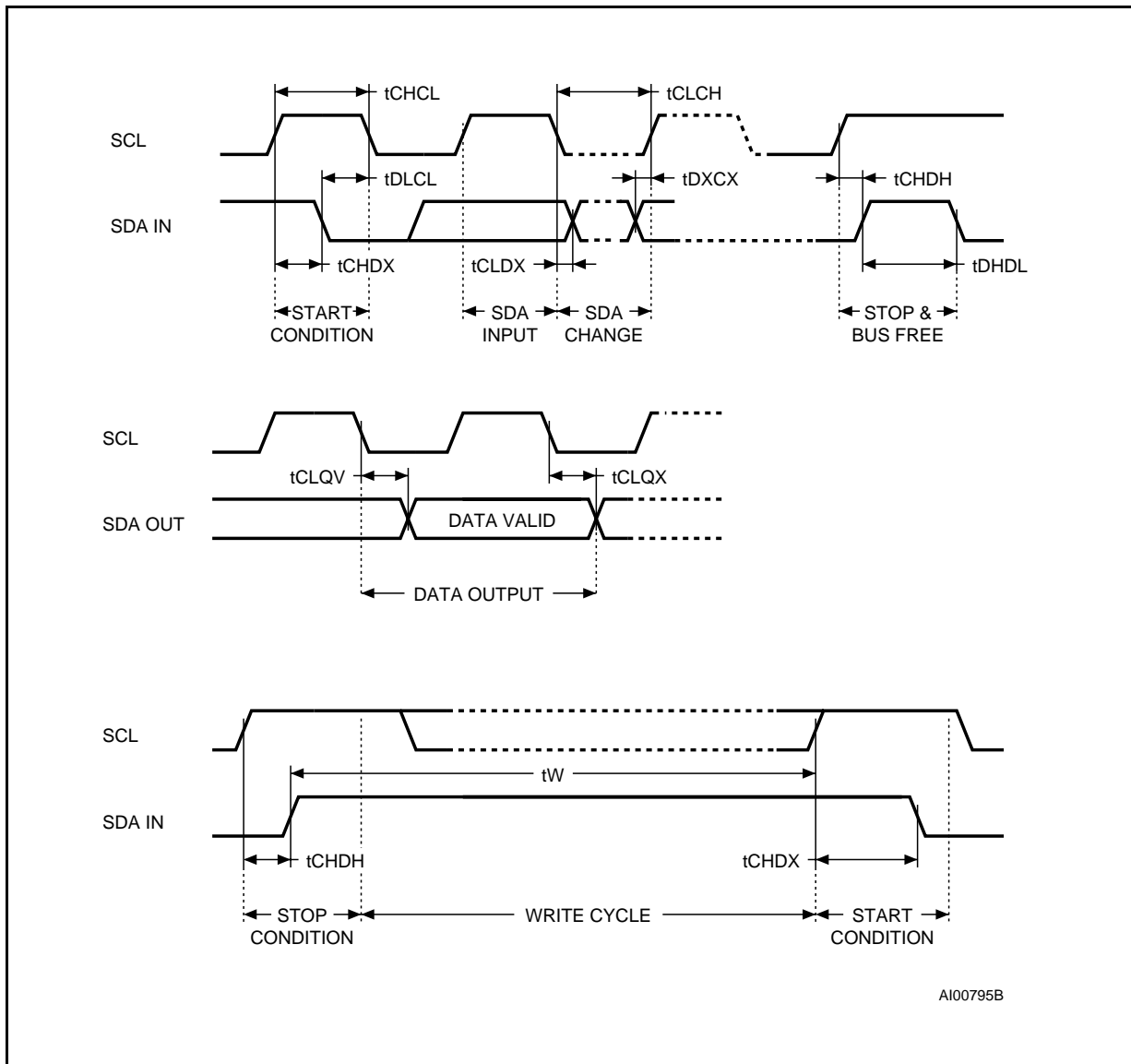


**DEVICE OPERATION (cont'd)**

The 4 most significant bits of the device select code are the device type identifier, corresponding to the I<sup>2</sup>C bus definition. For these memories the 4 bits are fixed as 1010b. The following bit identifies the specific memory on the bus. It is matched to the chip enable signal E. Thus up to 2 x 8K memories can be connected on the same bus giving a memory capacity total of 16 Kbits. After a START condition any memory on the bus will identify the device code and compare the following bit to its chip enable input E.

The 6th and 7th bits sent, select the block number (one block = 256 bytes). The 8th bit sent is the read or write bit (RW), this bit is set to '1' for read and '0' for write operations. If a match is found, the corresponding memory will acknowledge the identification on the SDA bus during the 9th bit time.

Figure 5. AC Waveforms



### Write Operations

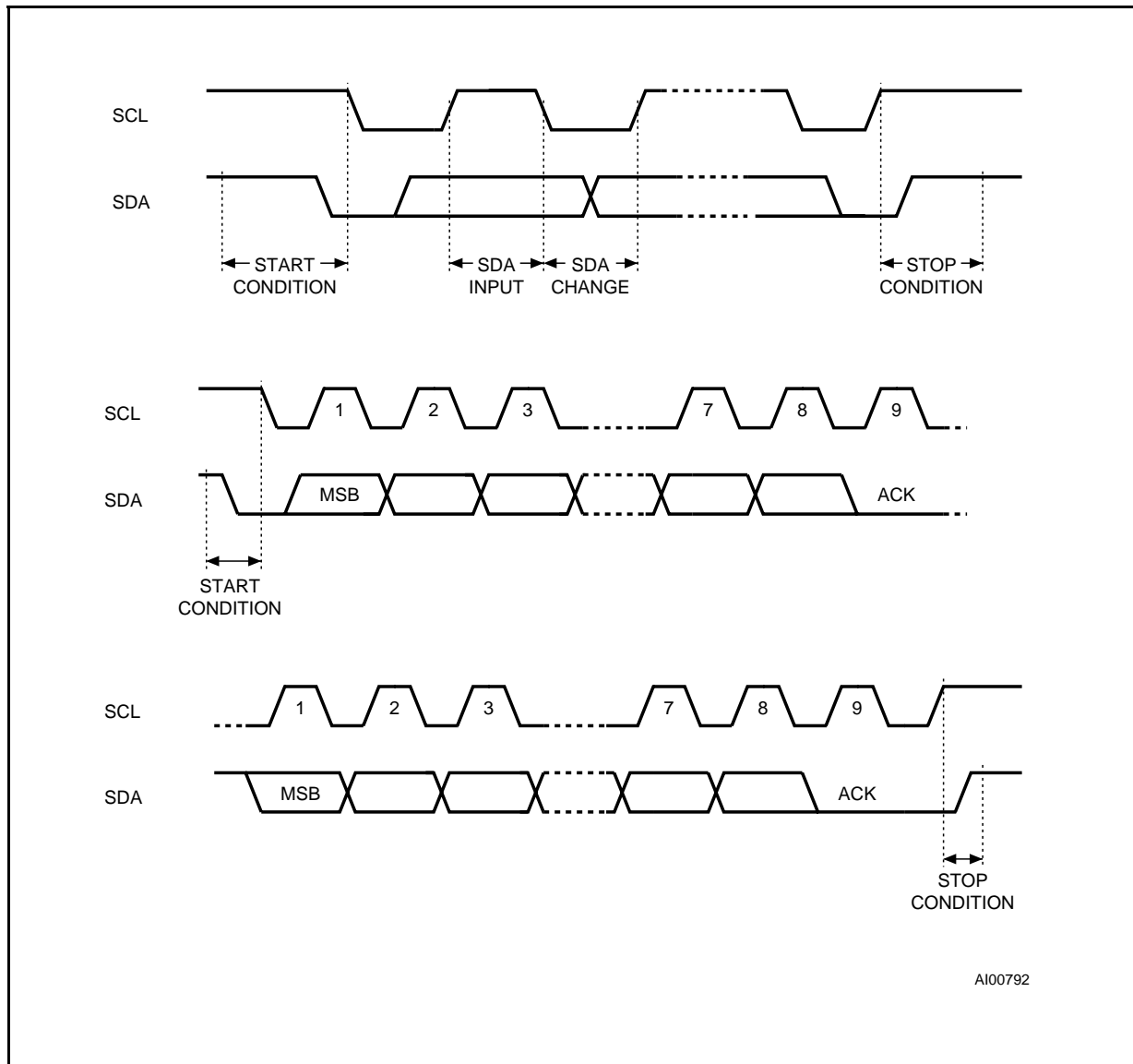
The Multibyte Write mode (only available on the ST24/25C08 versions) is selected when the MODE pin is at  $V_{IH}$  and the Page Write mode when MODE pin is at  $V_{IL}$ . The MODE pin may be driven dynamically with CMOS input levels.

Following a START condition the master sends a device select code with the  $\overline{RW}$  bit reset to '0'. The memory acknowledges this and waits for a byte address. The byte address of 8 bits provides access to one block of 256 bytes of the memory. After

receipt of the byte address the device again responds with an acknowledge.

For the ST24/25W08 versions, any write command with  $WC = 1$  will not modify the memory content.

**Byte Write.** In the Byte Write mode the master sends one data byte, which is acknowledged by the memory. The master then terminates the transfer by generating a STOP condition. The Write mode is independent of the state of the MODE pin which could be left floating if only this mode was to be used. However it is not a recommended operating mode, as this pin has to be connected to either  $V_{IH}$  or  $V_{IL}$ , to minimize the standby current.

Figure 6. I<sup>2</sup>C Bus Protocol

**Multibyte Write.** For the Multibyte Write mode, the MODE pin must be at  $V_{IH}$ . The Multibyte Write mode can be started from any address in the memory. The master sends from one up to 8 bytes of data, which are each acknowledged by the memory. The transfer is terminated by the master generating a STOP condition. The duration of the write cycle is  $t_w = 10\text{ms}$  maximum except when bytes are accessed on 2 rows (that is have different values for the 5 most significant address bits A7-A3), the programming time is then doubled to a maximum of 20ms. Writing more than 8 bytes in the Multibyte Write mode may modify data bytes in an

adjacent row (one row is 16 bytes long). However, the Multibyte Write can properly write up to 16 consecutive bytes only if the first address of these 16 bytes is the first address of the row, the 15 following bytes being written in the 15 following bytes of this same row.

**Page Write.** For the Page Write mode the MODE pin must be at  $V_{IL}$ . The Page Write mode allows up to 16 bytes to be written in a single write cycle, provided that they are all located in the same 'row' in the memory: that is the 4 most significant memory address bits (A7-A4) are the same inside one block. The master sends from one up to 16 bytes



of data, which are each acknowledged by the memory. After each byte is transferred, the internal byte address counter (4 least significant bits only) is incremented. The transfer is terminated by the master generating a STOP condition. Care must be taken to avoid address counter 'roll-over' which could result in data being overwritten. Note that, for any write mode, the generation by the master of the STOP condition starts the internal memory program cycle. All inputs are disabled until the completion of this cycle and the memory will not respond to any request.

**Minimizing System Delays by Polling On ACK.** During the internal write cycle, the memory disconnects itself from the bus in order to copy the data from the internal latches to the memory cells. The maximum value of the write time ( $t_w$ ) is given in the AC Characteristics table, since the typical time is shorter, the time seen by the system may be reduced by an ACK polling sequence issued by the master.

Figure 7. Memory Protection

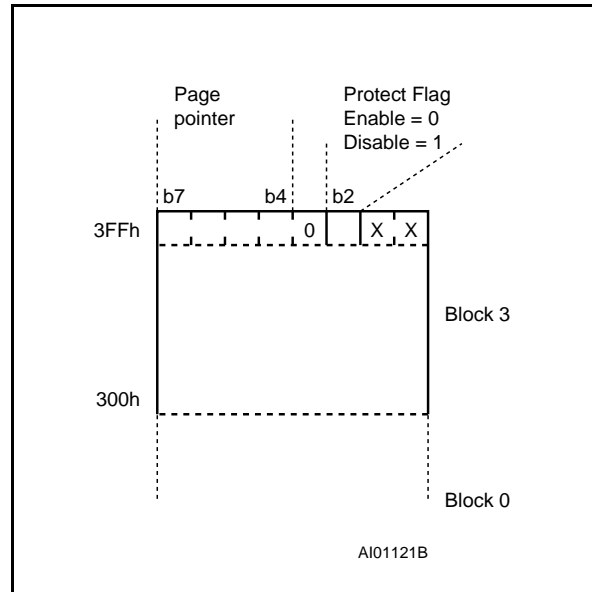


Figure 8. Write Cycle Polling using ACK

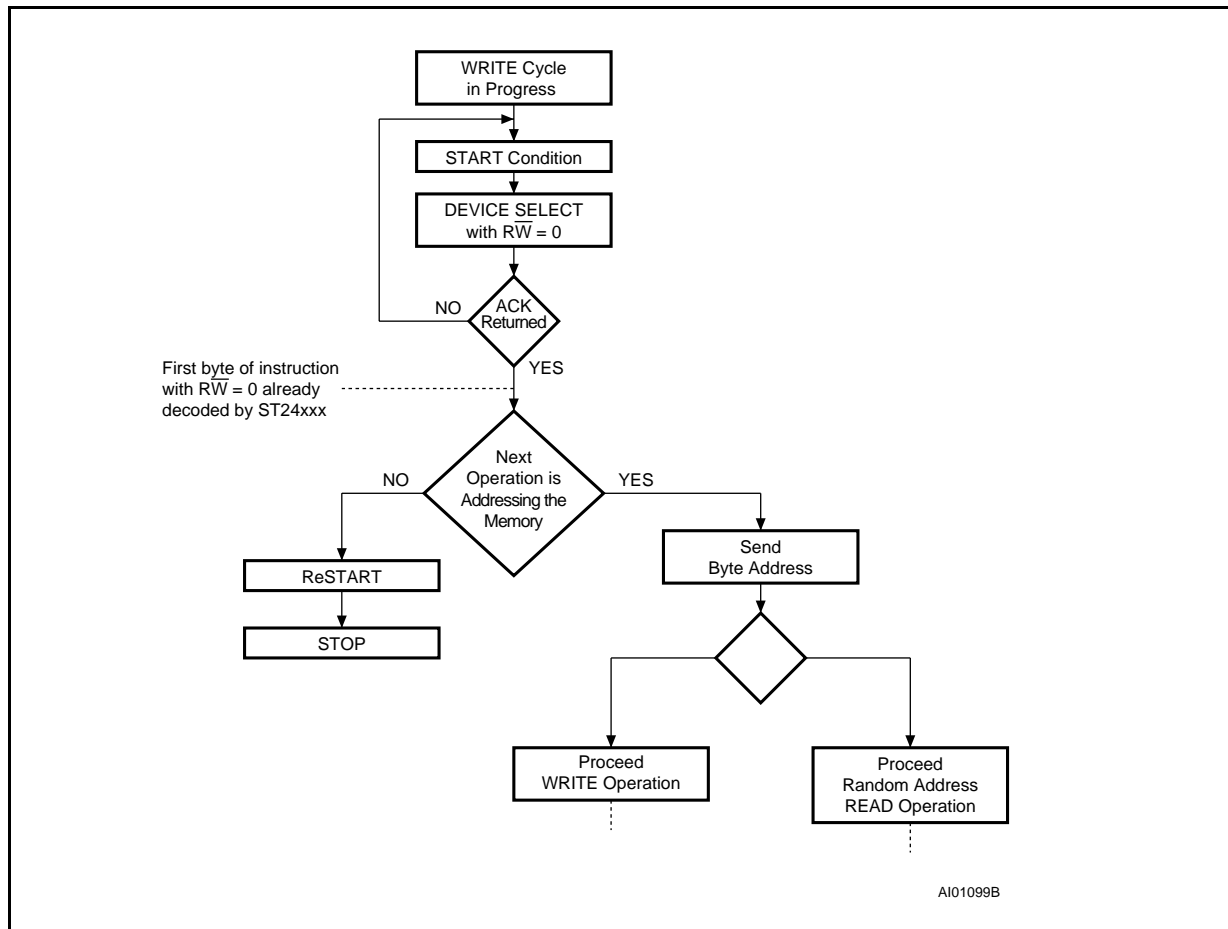
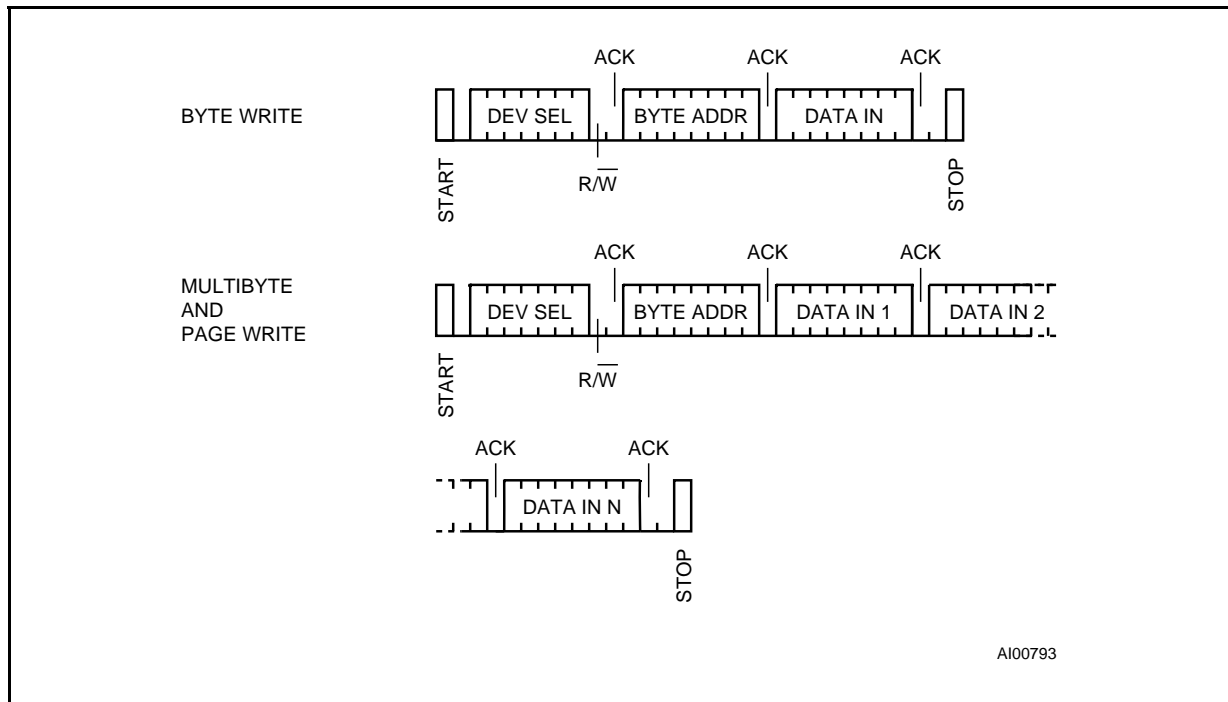


Figure 9. Write Modes Sequence (ST24/25C08)

**DEVICE OPERATION** (cont'd)

The sequence is as follows:

- Initial condition: a Write is in progress (see Figure 8).
- Step 1: the Master issues a START condition followed by a Device Select byte (1st byte of the new instruction).
- Step 2: if the memory is busy with the internal write cycle, no ACK will be returned and the master goes back to Step 1. If the memory has terminated the internal write cycle, it will respond with an ACK, indicating that the memory is ready to receive the second part of the next instruction (the first byte of this instruction was already sent during Step 1).

**Write Protection.** Data in the upper block of 256 bytes of the memory may be write protected. The memory is write protected between a boundary address and the top of memory (address 3FFh) when the PRE input pin is taken high and when the Protect Flag (bit b2 in location 3FFh) is set to '0'. The boundary address is user defined by writing it in the Block Address Pointer. The Block Address Pointer is an 8 bit EEPROM register located at the address 3FFh. It is composed by 4 MSBs Address Pointer, which defines the bottom boundary address, and 4 LSBs which must be programmed at '0'. This Address Pointer can therefore address a

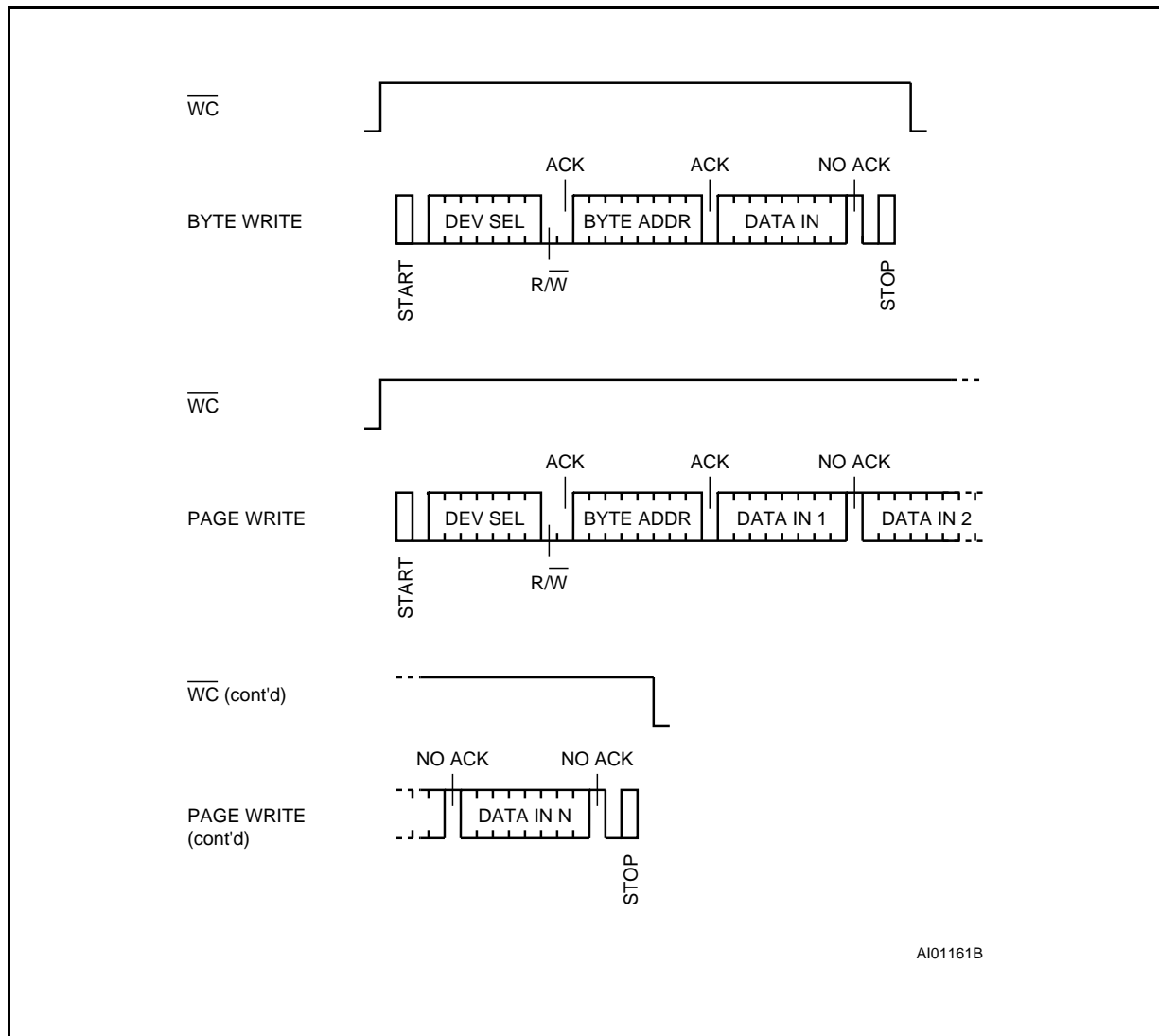
boundary in steps of 16 bytes. The sequence to use the Write Protected feature is:

- write the data to be protected into the top of the memory, up to, but not including, location 3FFh;
- set the protection by writing the correct bottom boundary address in the Address pointer (4 MSBs of location 3FFh) with the bit b2 (Protect flag) set to '0'.

Note that for a correct functionality of the memory, all the 4 LSBs of the Block Address Pointer must also be programmed at '0'. The area will now be protected when the PRE input pin is taken High. While the PRE input pin is read at '0' by the memory, the location 3FFh can be used as a normal EEPROM byte.

**Caution:** Special attention must be used when using the protect mode together with the Multibyte Write mode (MODE input pin High). If the Multibyte Write starts at the location right below the first byte of the Write Protected area, then the instruction will write over the first 7 bytes of the Write Protected area. The area protected is therefore smaller than the content defined in the location 3FFh, by 7 bytes. This does not apply to the Page Write mode as the address counter 'roll-over' and thus cannot go above the 16 bytes lower boundary of the protected area.

Figure 10. Write Modes Sequence with Write Control = 1 (ST24/25W08)



### Read Operations

Read operations are independent of the state of the MODE pin. On delivery, the memory content is set at all "1's" (or FFh).

**Current Address Read.** The memory has an internal byte address counter. Each time a byte is read, this counter is incremented. For the Current Address Read mode, following a START condition, the master sends a memory address with the  $\overline{R/W}$  bit set to '1'. The memory acknowledges this and outputs the byte addressed by the internal byte address counter. This counter is then incremented. The master does NOT acknowledge the byte output, but terminates the transfer with a STOP condition.

**Random Address Read.** A dummy write is performed to load the address into the address counter (see Figure 11). This is followed by another START condition from the master and the byte address is repeated with the  $\overline{R/W}$  bit set to '1'. The memory acknowledges this and outputs the byte addressed. The master has to NOT acknowledge the byte output, but terminates the transfer with a STOP condition.

**Sequential Read.** This mode can be initiated with either a Current Address Read or a Random Address Read. However, in this case the master DOES acknowledge the data byte output and the memory continues to output the next byte in sequence. To terminate the stream of bytes, the

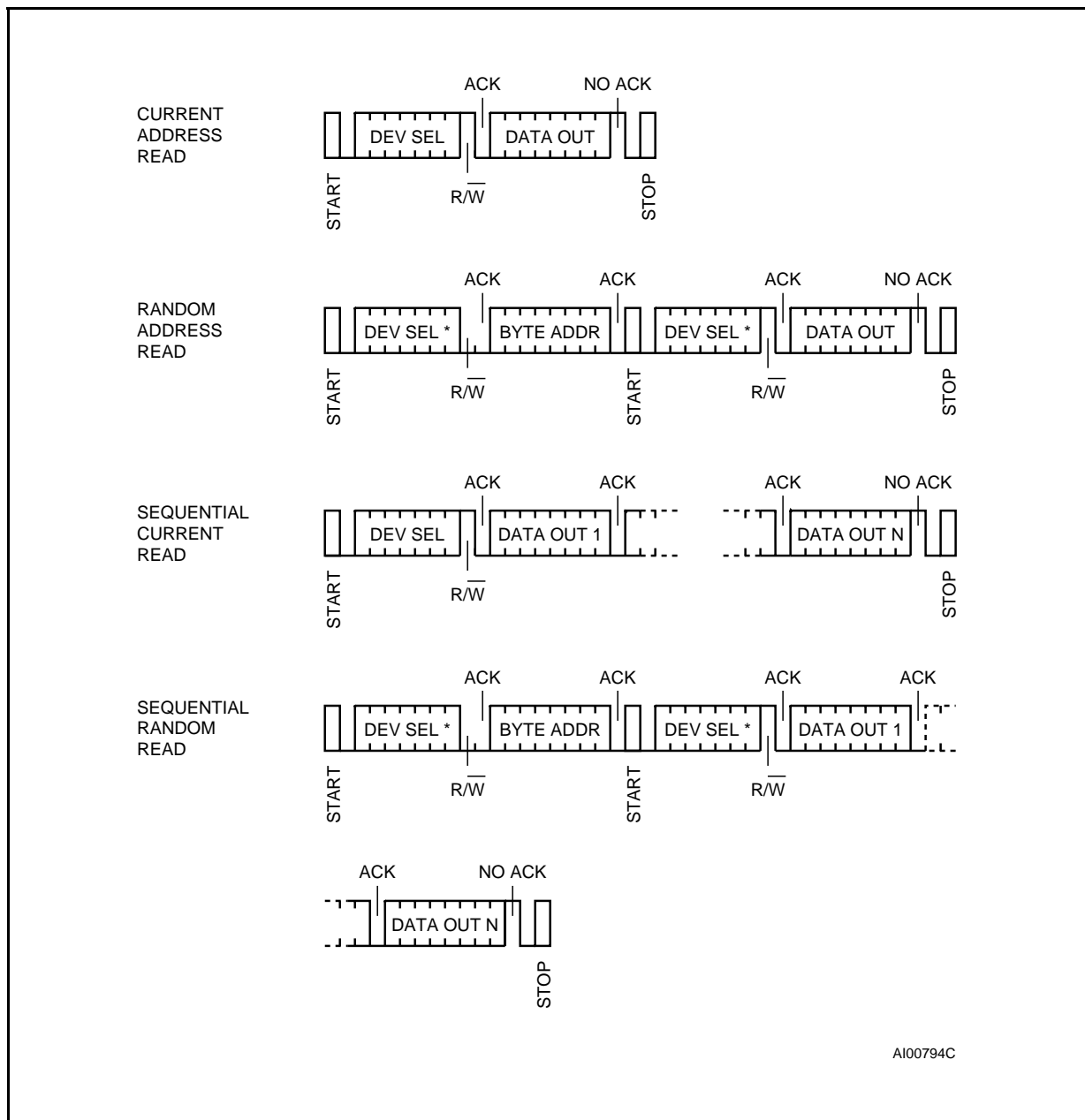
DEVICE OPERATION (cont'd)

master must NOT acknowledge the last byte output, but MUST generate a STOP condition. The output data is from consecutive byte addresses, with the internal byte address counter automatically incremented after each byte output. After a count of the last memory address, the address

counter will 'roll-over' and the memory will continue to output data.

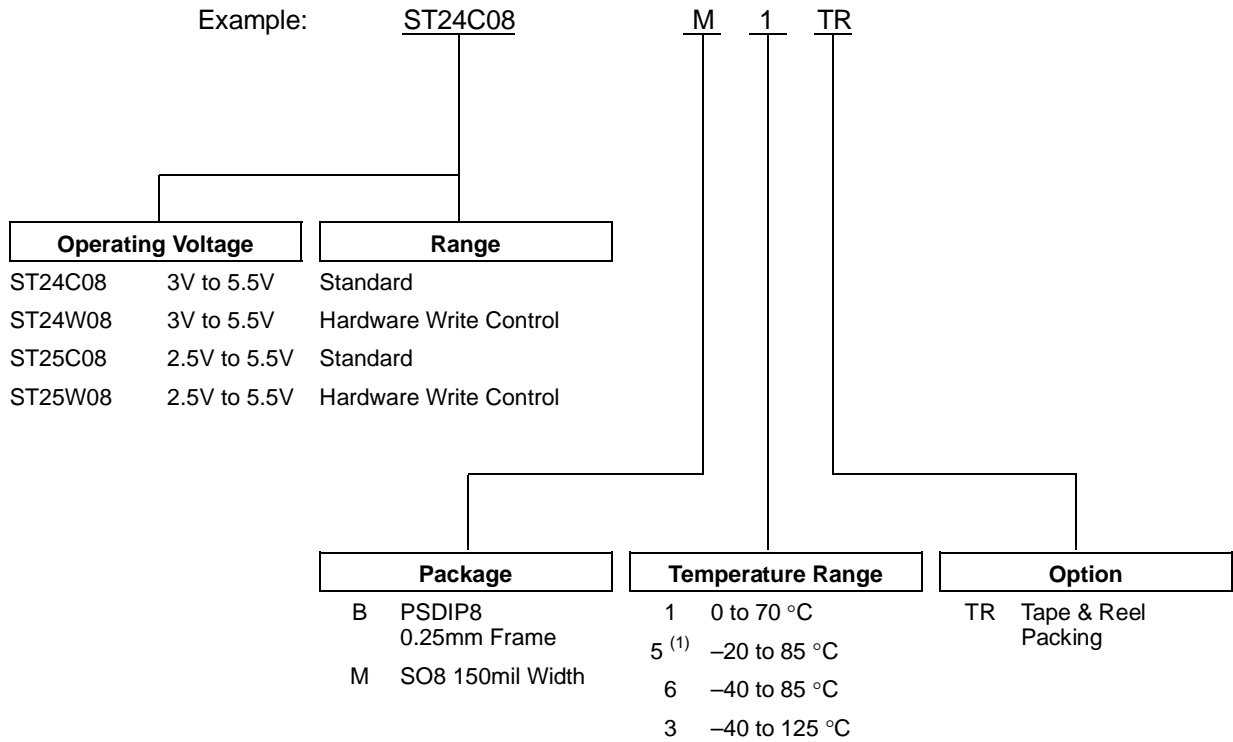
**Acknowledge in Read Mode.** In all read modes the ST24/25x08 wait for an acknowledge during the 9th bit time. If the master does not pull the SDA line low during this time, the ST24/25x08 terminate the data transfer and switches to a standby state.

Figure 11. Read Modes Sequence



**Note:** \* The 7 Most Significant bits of DEV SEL bytes of a Random Read (1st byte and 3rd byte) must be identical.

**ORDERING INFORMATION SCHEME**



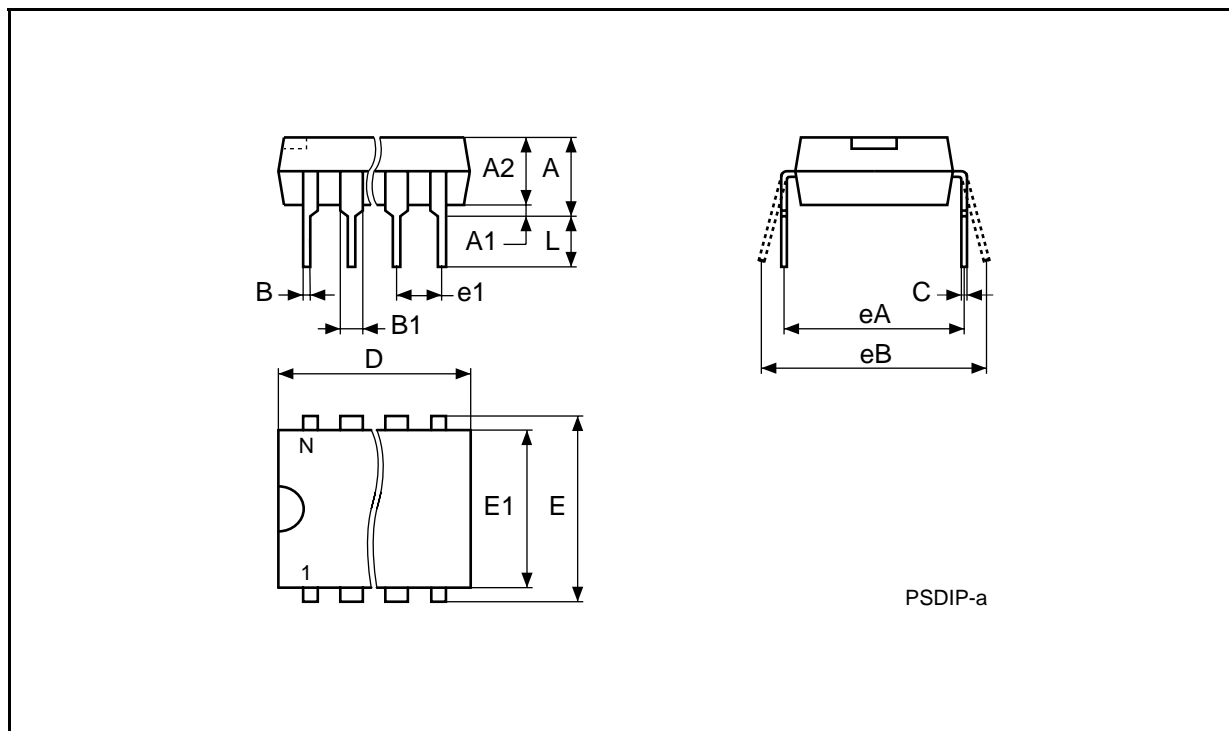
**Notes:** 1. Temperature range on special request only.

Devices are shipped from the factory with the memory content set at all "1's" (FFh).

For a list of available options (Operating Voltage, Package, etc...) or for further information on any aspect of this device, please contact the STMicroelectronics Sales Office nearest to you. to you.

**PSDIP8 - 8 pin Plastic Skinny DIP, 0.25mm lead frame**

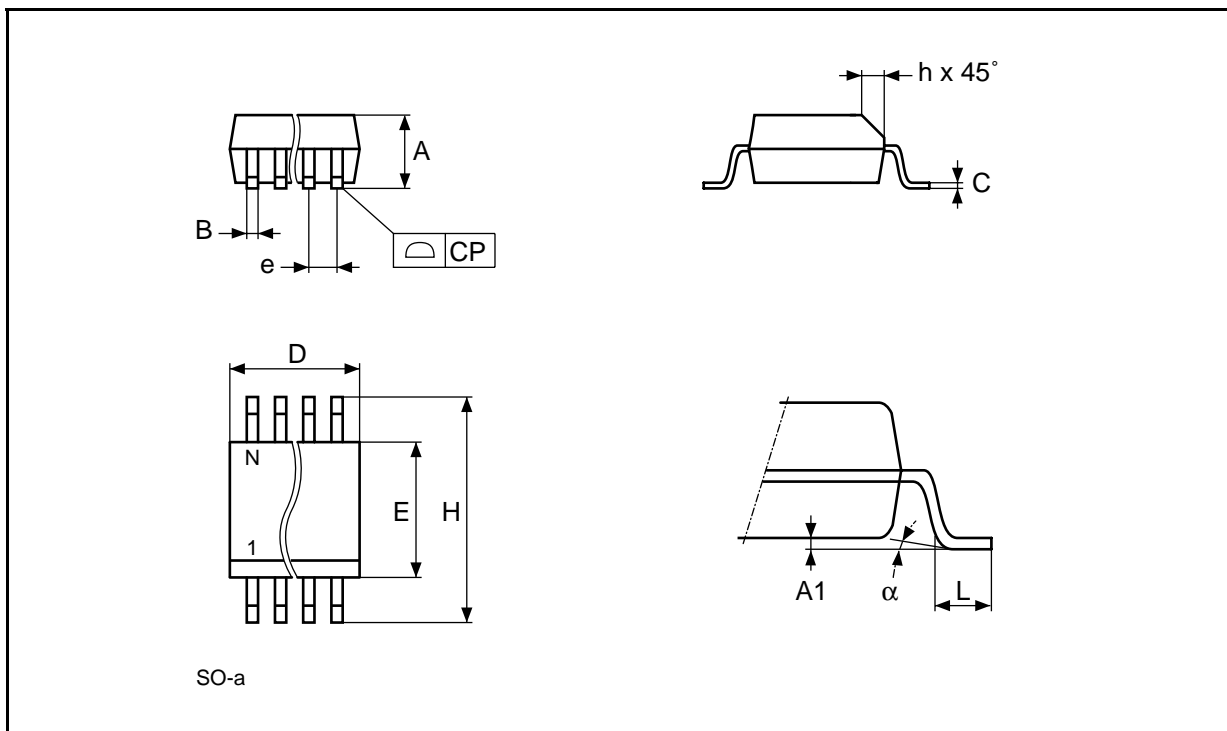
Symb	mm			inches		
	Typ	Min	Max	Typ	Min	Max
A		3.90	5.90		0.154	0.232
A1		0.49	–		0.019	–
A2		3.30	5.30		0.130	0.209
B		0.36	0.56		0.014	0.022
B1		1.15	1.65		0.045	0.065
C		0.20	0.36		0.008	0.014
D		9.20	9.90		0.362	0.390
E	7.62	–	–	0.300	–	–
E1		6.00	6.70		0.236	0.264
e1	2.54	–	–	0.100	–	–
eA		7.80	–		0.307	–
eB		–	10.00		–	0.394
L		3.00	3.80		0.118	0.150
N		8			8	



PSDIP-a

Drawing is not to scale

SO8 - 8 lead Plastic Small Outline, 150 mils body width							
Symb	mm			inches			
	Typ	Min	Max	Typ	Min	Max	
A		1.35	1.75		0.053	0.069	
A1		0.10	0.25		0.004	0.010	
B		0.33	0.51		0.013	0.020	
C		0.19	0.25		0.007	0.010	
D		4.80	5.00		0.189	0.197	
E		3.80	4.00		0.150	0.157	
e	1.27	–	–	0.050	–	–	
H		5.80	6.20		0.228	0.244	
h		0.25	0.50		0.010	0.020	
L		0.40	0.90		0.016	0.035	
$\alpha$		0°	8°		0°	8°	
N		8			8		
CP			0.10			0.004	



Drawing is not to scale

Information furnished is believed to be accurate and reliable. However, STMicroelectronics assumes no responsibility for the consequences of use of such information nor for any infringement of patents or other rights of third parties which may result from its use. No license is granted by implication or otherwise under any patent or patent rights of STMicroelectronics. Specifications mentioned in this publication are subject to change without notice. This publication supersedes and replaces all information previously supplied. STMicroelectronics products are not authorized for use as critical components in life support devices or systems without express written approval of STMicroelectronics.

The ST logo is a registered trademark of STMicroelectronics

© 1999 STMicroelectronics - All Rights Reserved

All other names are the property of their respective owners

STMicroelectronics GROUP OF COMPANIES

Australia - Brazil - Canada - China - France - Germany - Italy - Japan - Korea - Malaysia - Malta - Mexico - Morocco - The Netherlands - Singapore - Spain - Sweden - Switzerland - Taiwan - Thailand - United Kingdom - U.S.A.

<http://www.st.com>



This datasheet has been download from:

[www.datasheetcatalog.com](http://www.datasheetcatalog.com)

Datasheets for electronics components.