

Project No. 项目编号	DBT066MONO			
Customer 客户名称				
Module No. 客户型号				
Product type 产品内容	Standard LCD Module 4098 x 2560 Dots 6.6"MoNo TFT IPS LCD			
Signature by customer: 客户确认签章:				
编 制	电子审核	结构审核	品质审核	批 准

Contents

1. Document revision history.....	3
2. OutLine Drawing.....	4
3. Mechanical Specifications.....	5
4. DC Characteristics.....	5-6
5. Interface signals.....	7
6. Inspection Criteria.....	8-9
7. RELIABILITY TEST ITEM.....	10
8. Precautions for Use of LCD Modules.....	11-12
9. Packing.....	13

1 Document revision history :

DOCUMENT REVISION	DATE	DESCRIPTION	PREPARED BY	APPROVED BY
A	2021.05.28	First Release.		

3.Mechanical Specifications

Parameter		Specifications	Unit
Outline dimensions		154.36(W) x 99.1(H) x1.22(D)	mm
MONOTFT 4098x2560	LCD active area	143.43(W) x189.6(H)	mm
	Display format	4098 x 2560	dots
	Color configuration	MONO	-
	Dot pitch	0.035(W)x0.035(H)	mm
	Viewing Direction	FREE	-

3. DC Characteristics

4. 4.1 ABSOLUTE MAXIMUM RATINGS

Item	Symbol	Values		Unit	Condition
		Min.	Max.		
Storage Temperature	Tst	-10	80	°C	T _A =25°C
Operation Temperature (Ambient Temperature)	Top	-0	70	°C	T _A =25°C
Humidity	-		90	%RH	T _A ≤60°C Without dewing

4.2Typical operating Condition

parameter	Symbol	Spec.			Unit
		Min	Typ	Max	
VDDI Voltage	VDDI	1.7	1.8	3.6	V
VCI voltage	VCI	2.7	3.3	6.5	V
VSP voltage	VSP	4.0	-	6.5	V
VSN voltage	VSN	-6.5	-	-4.0	V
VGH-VGL voltage	VGH-VGL	-	-	32	V
VDD_OTP(OTP Power)	VDD_OTP	8.4	8.5	8.6	V

4.3 Dc Electrical Characteristics

Parameter		Symbol	Spec.			Unit
			Min	Typ	Max	
VDDI Input high level voltage1		VIH1	0.8XVDDI	-	VDDI	V
VDDI Input low level voltage1		VIL1	VSS	-	0.2XVDDI	V
Input leakage current		IL1	-1	-	+1	V
VGLO2 output voltage		VGLO2	-15	-	-5	V
VGMAH output voltage		VGMAH	3.05	-	6.2	V
VGMAL output voltage		VGMAL	-6.2	-	-3.05	V
VCI_REG output voltage		VCI_REG	2.1	-	3.0	V
VGLoutput voltage		VGL	-16	-	-6	V
VGH output voltage		VGH	8	-	19	V
VCL output voltage		VCL	-2.1	-2.4	-3.0	V
VCOM output voltage		VCOM	-2.75	-1.48	-0.2	V
Input terminal pull-high resistance		RPU	-	300	-	K Ω
Input terminal pull-low resistance		RPD	-	300	-	K Ω
Source output level deviation	Graycode=0~14 Graycode=241~255	Sdev1	40	-	-	mV
	Graycode=15~31 Graycode=208~240	Sdev2	30	-	-	mV
	Graycode=32~207	Sdev3	20	-	-	mV
Source output offset deviation	Graycode=0~14 Graycode=241~255	Sdev4	50	-	-	mV
	Graycode=15~31 Graycode=208~240	Sdev5	40	-	-	mV
	Graycode=32~207	Sdev6	30	-	-	mV
Current consumption	Normal mode(1)	Ivdd	-	-	18.3	mA
		Ivci	-	-	2.5	mA
	STBYB mode	Ivdd	-	-	0.95	mA
		Ivci	-	-	0.55	mA
Rush current		Ivddpeak	-	60	-	mA
VDD_OTP operation current		IVDD OTP	-	-	8	mA

5. Interface signals

PIN ASSIGNMENT:

1	GND	26	DON_S
2	D2N_M	27	DOP_S
3	D2P_M	28	GND
4	GND	29	D3N_S
5	D1N_M	30	D3P_S
6	D1P_M	31	GND
7	GND	32	GND
8	CLKN_M	33	TE
9	CLKP_M	34	RESET
10	GND	35	NC
11	DON_M	36	GND
12	DOP_M	37	VCC_3.3V
13	GND	38	GND
14	D3N_M	39	Iovcc (1.8V)
15	D3P_M	40	GND
16	GND	41	GND
17	D2N_S	42	NC
18	D2P_S	43	VSN
19	GND	44	NC
20	D1N_S	45	VSP
21	D1P_S	46	NC
22	GND	47	LEDA
23	CLKN_S	48	NC
24	CLKP_S	49	LEDK
25	GND	50	GND

6.INSPECTION CRITERIA

6.1 检验条件及环境

- 1)在自然光或 60W-100w(照度达 600~800Lux)冷白荧光灯照明条件下检验。
- 2) 观察距离:300-350mm
- 3)观察角度:水平方位 45° 士 15°
- 4)检验时按正常要求的距离和角度扫描整个被检测面:10S±5S
- 5) 检验人员裸视或矫正视力 1.0 以上, 不能有色盲、色弱者。

6.2 抽样标准

抽样检验依 GB2828-2003 标准, 取一般检验水平 II。

AQL:A 类缺陷为 0

B 类缺陷为 0.4

C 类缺陷为 1.0

特殊项目(尺寸、可靠性)抽样方案为:S-1 或具体规定数量, Ac=0, Re=1

6.3检验步骤及项目

项目	检查内容	判定标准	检验工具	缺陷等级
外包装	进料标签	进料标签上必须有供应商名称, 产品名称, 产品型号, 产品料号, 产品数量, 生产日期, 并应有厂商的检验合格章	目测	CR
	厂商、规格核对	厂商和规格应和 BOM 中要求的相符	目测	CR
	外包装	包装材料应设计合理, 无包装破损, 变形, 受潮等不良	目测	CR
	ROHS 符合性	ROHS 物料需要有合格的 ROHS 测试报告, 外箱应贴有 RoHS 标示	目测	CR
外观	金手指	折断、折痕、缺损、氧化不允许	目测	MA
	保护膜	不允许漏贴, 保护膜翘起、贴尘	目测	MI
	脏污	金手指和屏表面不允许有	目测	MI
	FPC	FPC 折弯处不允许有断裂	目测	MI

	点状不良	黑点、颗粒、异物点	D≤0.1mm 不计(不允许密集) 0.1<D≤0.2mm 允许 2 个 ds>20mm D>0.2mm NG	目测、菲林卡	MI
		白点、LCD 亮点	D≤0.1mm 不计(不允许密集) 0.1<D≤0.3mm 允许 2 个 ds>20mm 0.3<D≤0.5mm 允许 1 个 ds>20mm D>0.5mm NG		
	LCD 划伤、刮伤、线状异物	W≤0.02mm 不计 0.02<W≤0.05mm L≤2mm 1 个 W>0.05mm NG	目测、菲林卡	MI	
	缺角	缺角伤到线路、框边 NG	目测	MA	
	裂痕	不允许	目测	MA	
	破片	不允许	目测	MA	
结构	尺寸	按照规格书上的图纸检验	卡尺	MA	
	对样	1. 颜色:胶框、双面胶、FPC、屏幕和样品不可有明显差异 2. 胶框、FPC、双面胶、支架等结构和组装方式、位置不可有变化 3. 材质:通过手感、软硬程度、厚薄度、颜色、表面效果判定是否和样品一致	样品	MA	
功能测试	亮点、暗点	点亮测试后屏幕有点缺陷, 依点状不良判定	测试架、目测、菲林卡	MI	
	亮线	点亮测试后屏幕有线缺陷(垂直或水平亮线、暗线)	测试架、目测	MA	
	显示异常	点亮测试后屏幕少显示、多显示、画面跳动, 画面应流畅, 无拖影	测试架、目测	MA	
	显示不均	点亮后同样的驱动条件下, 同一画面下, 同样的观察条件下, 屏幕部分显示亮暗差异现象。	测试架、目测	MA	
	色差	点亮后同样的驱动条件下, 同一画面下, 同样的观察条件下, 产品显示偏白或偏红或偏兰或偏绿等, 以限度样品 判定。	测试架、目测	MA	

7. RELIABILITY TEST ITEM

可靠性测试	高温储存	测试方法:70°C±2°C存储 24H ,判定标准:测试后电性能和显示效果正常	高低温测试仪	MI
	低温储存	测试方法:-40°C±2°C存储 24H ,判定标准:测试后电性能和显示效果正常	高低温测试仪	MA
	高温高温	测试方法:70°C±2°C 95%RH 72H ,判定标准:测试后电性能和显示效果正常	高低温测试仪	MA
	冷热冲击	测试测试方法:(-10 °C *30min-25 °C *5min 70°C*30min)30 个循环,判定标准:测试后电性能和显示效果正常	冷热冲击测试仪	MA
	FPC 弯折试验	验测试方法:按实际组装时弯折角度 50 次,判定标准:检验 FPC 之曲绕寿命,无断裂, LCD 电性能正常	手工	MA

8. Precautions for Use of LCD Modules

8.1 Handling Precautions

8.1.1 The display panel is made of glass. Do not subject it to a mechanical shock by dropping it from a high place, etc.

8.1.2 If the display panel is damaged and the liquid crystal substance inside it leaks out, be sure not to get any in your mouth, if the substance comes into contact with your skin or clothes, promptly wash it off using soap and water.

8.1.3 Do not apply excessive force to the display surface or the adjoining areas since this may cause the color tone to vary.

8.1.4 The polarizer covering the display surface of the LCD module is soft and easily scratched. Handle this polarizer carefully.

8.1.5 If the display surface is contaminated, breathe on the surface and gently wipe it with a soft dry cloth. If still not completely clear, moisten cloth with one of the following solvents:

— Isopropyl alcohol

— Ethyl alcohol

Solvents other than those mentioned above may damage the polarizer.

Especially, do not use the following:

— Water

— Ketone

— Aromatic solvents

8.1.6 Do not attempt to disassemble the LCD Module.

8.1.7 If the logic circuit power is off, do not apply the input signals.

8.1.8 To prevent destruction of the elements by static electricity, be careful to maintain an optimum work environment.

a. Be sure to ground the body when handling the LCD Modules.

b. Tools required for assembly, such as soldering irons, must be properly ground.

c. To reduce the amount of static electricity generated, do not conduct

assembly and other work under dry conditions.

d. The LCD Module is coated with a film to protect the display surface.

Be care when peeling off this protective film since static electricity may be generated.

8.2 Storage precautions

8.2.1 When storing the LCD modules, avoid exposure to direct sunlight or to the light of fluorescent lamps.

8.2.2 The LCD modules should be stored under the storage temperature range. If the LCD modules will be stored for a long time, the recommend condition is:

Temperature : $0^{\circ}\text{C} \sim 40^{\circ}\text{C}$

Relatively humidity: $\leq 80\%$

8.2.3 The LCD modules should be stored in the room without acid, alkali and harmful gas.

8.3 The LCD modules should be no falling and violent shocking during transportation, and also should avoid excessive press, water, damp and sunshine.

9. Packing

Drawing Of Packing
包装方式

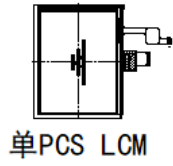

由 Autodesk 教育版产品制作

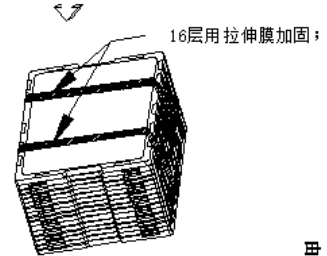
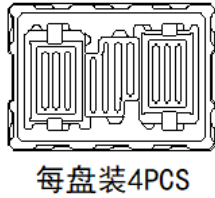

共16盘, 最顶1盘为空盘,
15盘装产品共60PCS

由 Autodesk 教育版产品制作

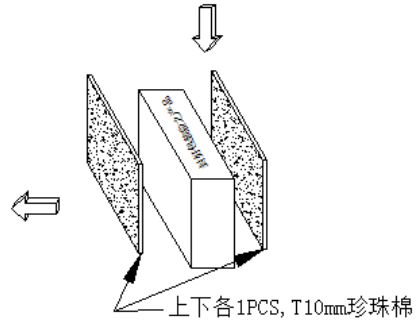
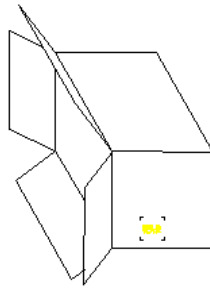

Autodesk 教育版产品制作