

PROJEKTOWANIE I WYKONANIE PRAC PROJEKTOWYCH
 W OBLASCI ELEKTROTECHNIKI I ELEKTRONIKI
 W OBLASCI SYSTEMOWYCH I SYSTEMOWYCH
 W OBLASCI SYSTEMOWYCH I SYSTEMOWYCH

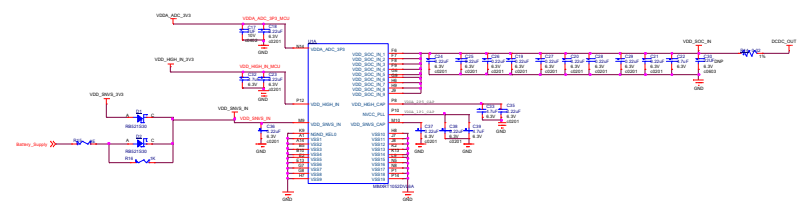

BUTTON

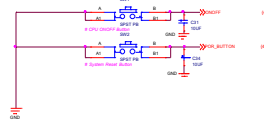

LCD 3V3 POWER SWITCH

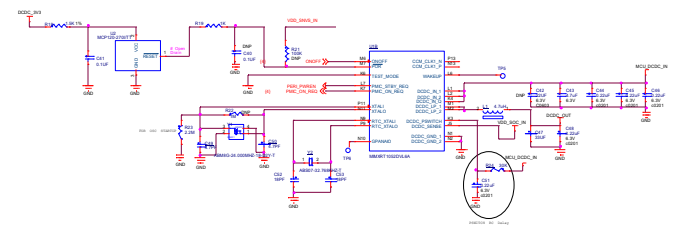
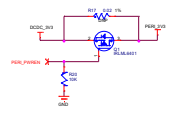

3V3 LDO for SNVS

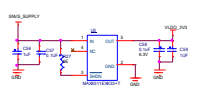

SNVS

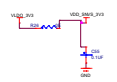

ADC

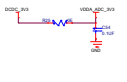

DCDC_IN

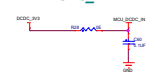

VDD_HIGH_IN



VER	ECO NO.	REL. DATE	CHANGE	DO	ENGR	APVD	NEXT ASSY. NUMBER	ITEM	QTY
MATERIAL			FINISH	PROJECTION			ALL DIMENSIONS IN MM UNLESS OTHERWISE SPECIFIED		LAB/OFFICE
DRAWN	CHECKED	ENGINEER	SCALE	TITLE			PCB ASSY-BOARD WELD CONTROLLER-80C		
DT: 27/07/2022	DT: 28/07/22	DT: 28/07/22	DOC TYPE	DOC NUMBER			SHEET NO. VER		
							2339 000 084 11		
							SHEET SHEETS		SIZE

100% COMPLIANT WITH THE ROHS DIRECTIVE
 ALL COMPONENTS ARE ROHS COMPLIANT
 UNLESS OTHERWISE SPECIFIED
 ALL DIMENSIONS ARE IN MILLIMETERS
 UNLESS OTHERWISE SPECIFIED

Backlight Control

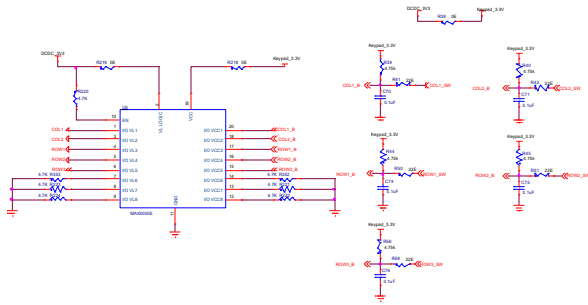
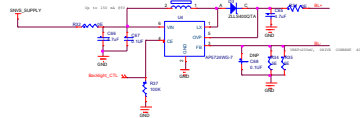

LCD CON

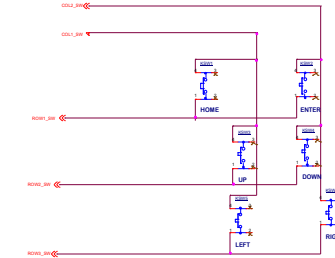
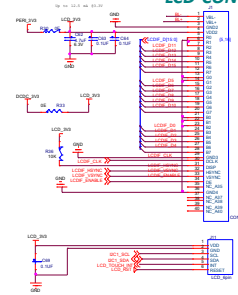

VER	ECO NO.	REL. DATE	CHANGE	DO	ENGR	APVD	REV'D ASBY	NUMBER	ITEM	QTY
SERIAL			FRUIT			PROJECTION			ALL DIMENSIONS IN MM UNLESS OTHERWISE SPECIFIED	
DRAWN	CHECKED	ENGINEER	SCALE	TITLE						
BT	BT	BT		PCB ASSY-BAND WELD CONTROLLED-PCB						
JOB NUMBER		JOB TYPE		2399 000 084 11				SHEET NO. / SHEETS		VER / SIZE

PROJECT: 2024-001
 SHEET: 004-01
 DATE: 2024-08-15

3V3 QSPI Flash

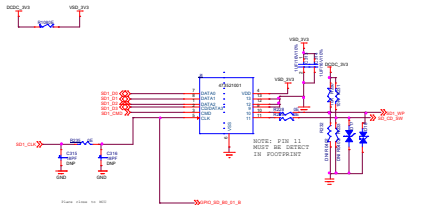
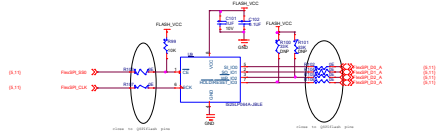

NOTE: PIN 11 MUST BE SOLDERED IN FOOTPRINT

ALL DIMENSIONS IN MILLIMETERS UNLESS OTHERWISE SPECIFIED
 UNLESS OTHERWISE SPECIFIED

REV	ECO NO.	REL DATE	CHANGE	DO	BY	CHKD	DATE	BY	DATE
DRAWN		CHECKED	ENGINEER	SCALE	TITLE		PCB ASSEMBLY WELD CONTROLLER-3V3		
BY	DATE	BY	DATE	BY	DATE	NO.	REV	SHEET NO. / TOTAL SHEETS	
								2024-001-004-01	

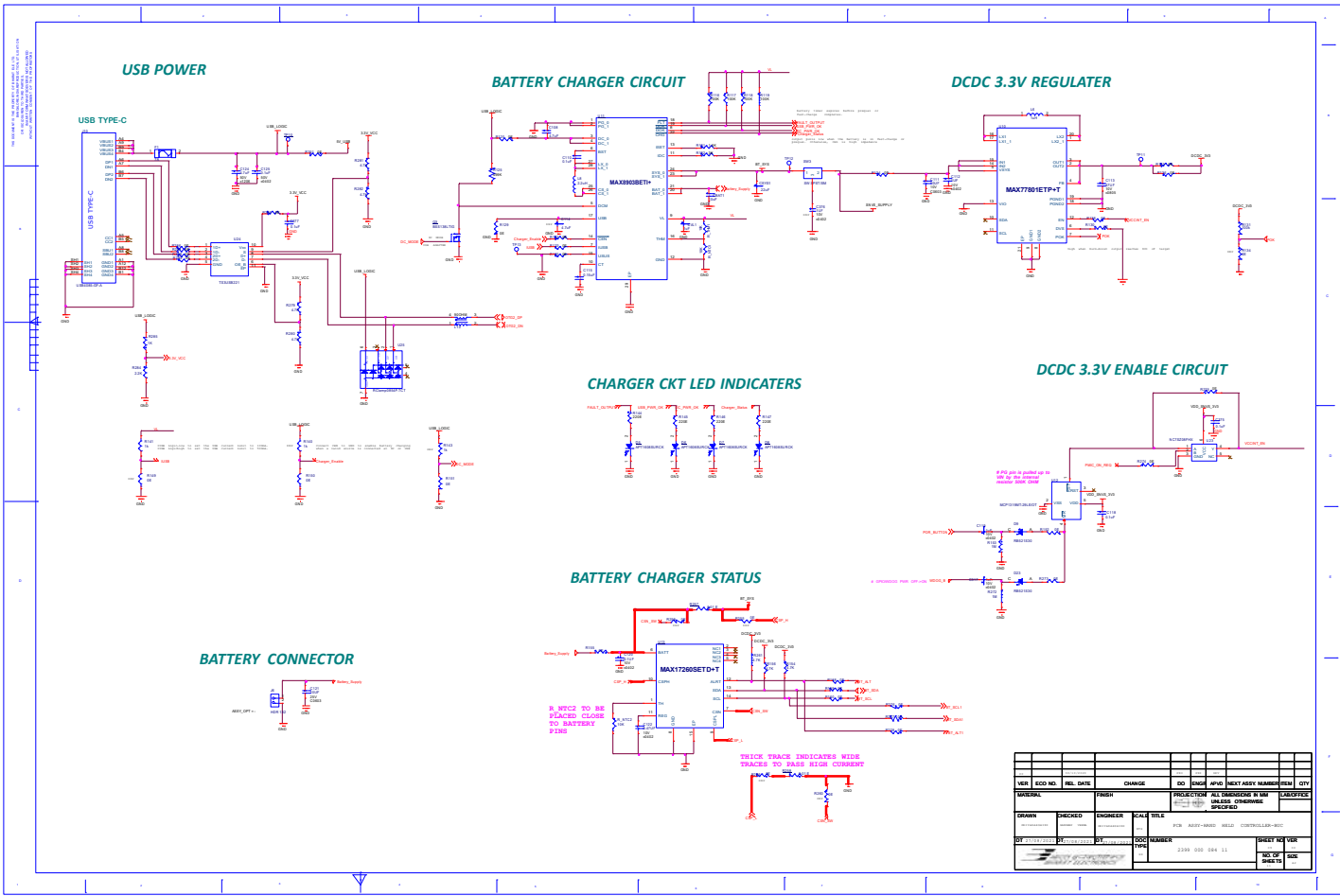

VER	ECO NO	REL DATE	CHANGE	DD	ENGR	APR	EXT ASBY	MANAGER	REV	QTY
DRAWN		CHECKED		ENGINEER		CNC		BILL		
BY		BY		BY		BY		BY		
DOC NO		DOC NO		DOC NO		DOC NO		DOC NO		
2000 000 004 11										
SHEET NO		SHEET NO		SHEET NO		SHEET NO		SHEET NO		
10 OF 10		10 OF 10		10 OF 10		10 OF 10		10 OF 10		

