

Product Specification

SPECIFICATION FOR APPROVAL

(◆) Preliminary Specification

() Final Specification

Title	9.7" QXGA TFT LCD
-------	-------------------

Customer	General
MODEL	

SUPPLIER	LG Display Co., Ltd.
*MODEL	LP097QX2
Suffix	SPAV

*When you obtain standard approval,
please use the above model name without suffix

APPROVED BY	SIGNATURE
/	_____
/	_____
/	_____

Please return 1 copy for your confirmation with your signature and comments.

APPROVED BY	SIGNATURE
J. K. Kim / S. Manager	_____
REVIEWED BY	
S.W.Moon/ Manager	_____
PREPARED BY	
H. S. Cha/ Engineer	_____

**Product Engineering Dept.
LG Display Co., Ltd**

Product Specification

Contents

No	ITEM	Page
	COVER	1
	CONTENTS	2
	RECORD OF REVISIONS	3
1	GENERAL DESCRIPTION	4
2	ABSOLUTE MAXIMUM RATINGS	5
3	ELECTRICAL SPECIFICATIONS	
3-1	ELECTRICAL CHARACTERISTICS	6
3-2	INTERFACE CONNECTIONS	7
3-3	LVDS SIGNAL TIMING SPECIFICATIONS	10
3-4	SIGNAL TIMING SPECIFICATIONS	11
3-5	SIGNAL TIMING WAVEFORMS	12
3-6	COLOR INPUT DATA REFERNECE	13
3-7	POWER SEQUENCE	14
4	OPTICAL SPECIFICATIONS	15
5	MECHANICAL CHARACTERISTICS	18
6	RELIABILITY	21
7	INTERNATIONAL STANDARDS	
7-1	SAFETY	22
7-2	EMC	22
8	PACKING	
8-1	DESIGNATION OF LOT MARK	23
8-2	PACKING FORM	23
9	PRECAUTIONS	24
A	APPENDIX. Enhanced Extended Display Identification Data	26

Product Specification

1. General Description

The LP097QX2 is a Color Active Matrix Liquid Crystal Display with an integral LED backlight system. The matrix employs a-Si Thin Film Transistor as the active element. It is a transmissive type display operating in the normally Black mode. This TFT-LCD has 9.7 inches diagonally measured active display area with QXGA resolution(1536 horizontal by 2048 vertical pixel array). Each pixel is divided into Red, Green and Blue sub-pixels or dots which are arranged in vertical stripes. Gray scale or the brightness of the sub-pixel color is determined with a 8-bit gray scale signal for each dot, thus, presenting a palette of more than 16,772,216 colors. The LP097QX2 has been designed to apply the interface method that enables low power, high speed, low EMI.

The LP097QX2 is intended to support applications where thin thickness, low power are critical factors and graphic displays are important. In combination with the vertical arrangement of the sub-pixels, the LP097QX2 characteristics provide an excellent flat display for office automation products such as Notebook PC.

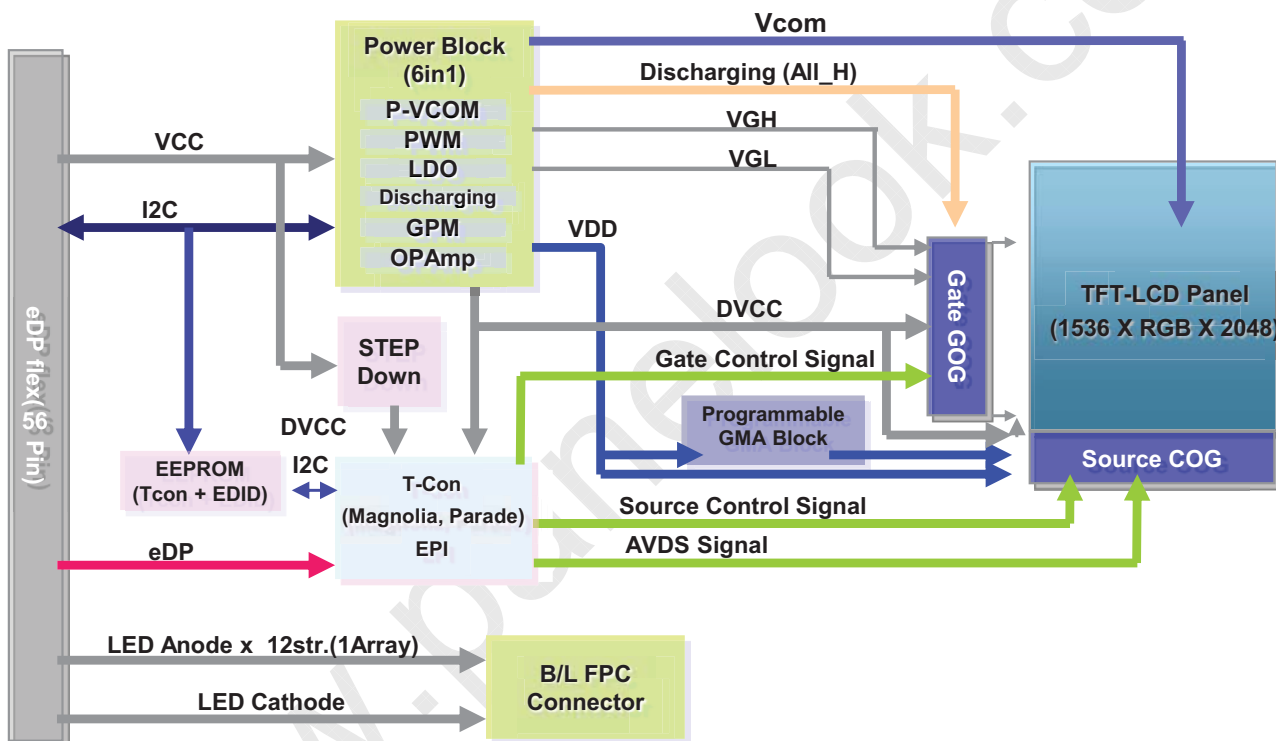

General Features

Active Screen Size	9.7 inches diagonal
Outline Dimension	160.30(H) x 208.93(V) x 2.08(T) mm (Typ.)
Pixel Pitch	0.192 mm x 0.192 mm
Pixel Format	1536 hor. By 2048 Vertical Pixels RGB stripes arrangement
Color Depth	8-bit, 16,772,216 colors
Luminance, White	440 cd/m ² (Typ., @I _{LED} =17.5mA)
Power Consumption	Logic : 0.8W(typ.@white), Back Light : 3.53W (typ.@ I _{LED} = 17.5mA)
Weight	112.0 g (max.)
Display Operating Mode	Transmissive mode, normally Black
Surface Treatment	Glare, Anti-reflective treatment of the front polarizer, 3H

Product Specification

2. Absolute Maximum Ratings

The following are maximum values which, if exceeded, may cause faulty operation or damage to the unit.

Table 1. ABSOLUTE MAXIMUM RATINGS

Parameter	Symbol	Values		Units	Notes
		Min	Max		
Power Input Voltage	VCC	-0.3	4.0	Vdc	at 25 ± 5°C
Operating Temperature	TOP	0	50	°C	1
Storage Temperature	HST	-20	60	°C	1
Operating Ambient Humidity	HOP	10	90	%RH	1
Storage Humidity	HST	10	90	%RH	1

Note : 1. Temperature and relative humidity range are shown in the figure below.
 Wet bulb temperature should be 39°C Max, and no condensation of water.

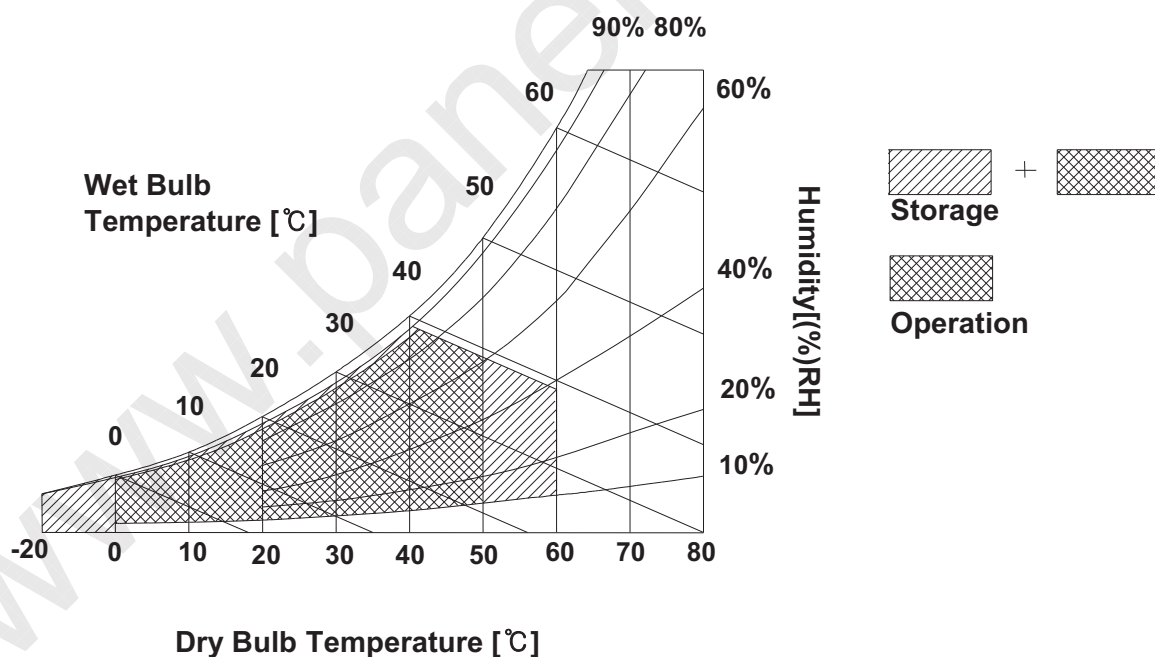

Product Specification

3. Electrical Specifications

3-1. Electrical Characteristics

The LP097X02 requires two power inputs. One is employed to power the LCD electronics and to drive the TFT array and liquid crystal. The second input which powers the LED BL.

Table 2. ELECTRICAL CHARACTERISTICS

Parameter	Symbol	Values			Unit	Notes
		Min	Typ	Max		
MODULE :						
Power Supply Input Voltage	VCC	3.0	3.7	4.8	V _{DC}	
Power Supply Input Current	I _{CC} Mosaic	193	215	237	mA	1
Power Consumption	Pc	-	0.8	0.88	Watt	1
Differential Impedance	Zm	80	90	100	Ohm	2
LED Backlight :						
(Without LED Driver)						
LED Driver input Volatge (on system)	VLED			12	V	3
Operating Current per string	I _{LED}		17.5		mA	4
Life Time		10,000	-	-	Hrs	5

Note)

1. The specified current and power consumption are under the Vcc = 3.3V , 25°C , fv = 60Hz condition whereas Mosaic pattern is displayed and fv is the frame frequency.

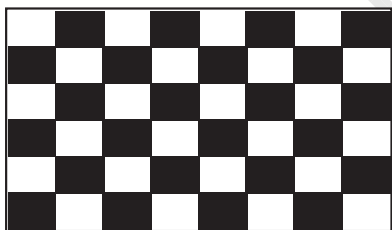

2. This impedance value is needed to proper display and measured form LVDS Tx to the mating connector.
3. **LED input voltage must be input below than 12V to operate normally for LED Driver.**
4. The typical operating current is for the typical surface luminance (L_{WH}) in optical characteristics.
5. The LED power consumption shown above does not include power of external LED driver circuit for typical current condition.
6. The life time is determined as the time at which brightness of lamp is 50% compare to that of initial value at the typical lamp current.

Product Specification

3-2. Interface Connections

Table 3. MODULE CONNECTOR PIN CONFIGURATION (CN1)

Pin	Symbol	Description	Pin	Symbol	Description
1	GND	Ground	2	GND	Ground
3	LED Cathode 1B	LED Cathode (Negative)	4	LED Cathode 6A	LED Cathode (Negative)
5	LED Cathode 2B	LED Cathode (Negative)	6	LED Cathode 5A	LED Cathode (Negative)
7	LED Cathode 3B	LED Cathode (Negative)	8	LED Cathode 4A	LED Cathode (Negative)
9	LED Cathode 4B	LED Cathode (Negative)	10	LED Cathode 3A	LED Cathode (Negative)
11	LED Cathode 5B	LED Cathode (Negative)	12	LED Cathode 2A	LED Cathode (Negative)
13	LED Cathode 6B	LED Cathode (Negative)	14	LED Cathode 1A	LED Cathode (Negative)
15	GND	Ground	16	HPD	Hot Plug detect
17	Vin	VCC 3.7V(typ.)	18	GND	Ground
19	Vin	VCC 3.7V(typ.)	20	LANE0_N	Complement Signal Link Lane 0
21	Vin	VCC 3.7V(typ.)	22	LANE0_P	True Signal Link Lane 0
23	Vin	VCC 3.7V(typ.)	24	GND	Ground
25	GND	Ground	26	LANE1_N	Complement Signal Link Lane 1
27	GND	Ground	28	LANE1_P	True Signal Link Lane 1
29	AUX_N	Complement Signal Auxiliary Ch.	30	GND	Ground
31	AUX_P	True Signal Auxiliary Ch.	32	LANE2_N	Complement Signal Link Lane 2
33	NC		34	LANE2_P	True Signal Link Lane 2
35	LED Anode 1	LED Anode A	36	GND	Ground
37	LED Anode 1	LED Anode A	38	LANE3_N	Complement Signal Link Lane 3
39	LED Anode 2	LED Anode B	40	LANE3_P	True Signal Link Lane 3
41	LED Anode 2	LED Anode B	42	GND	Ground

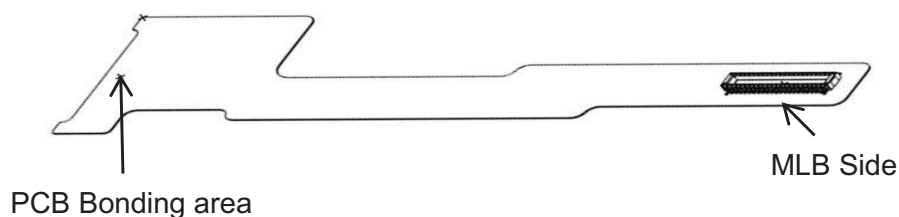

[eDP Receiver]
 Parade 株式会社, Magnolia2
 [Connector]
 eDP Flex
 [Connector pin arrangement]
 LCD front view

Product Specification

FIG. 4 Connector diagram

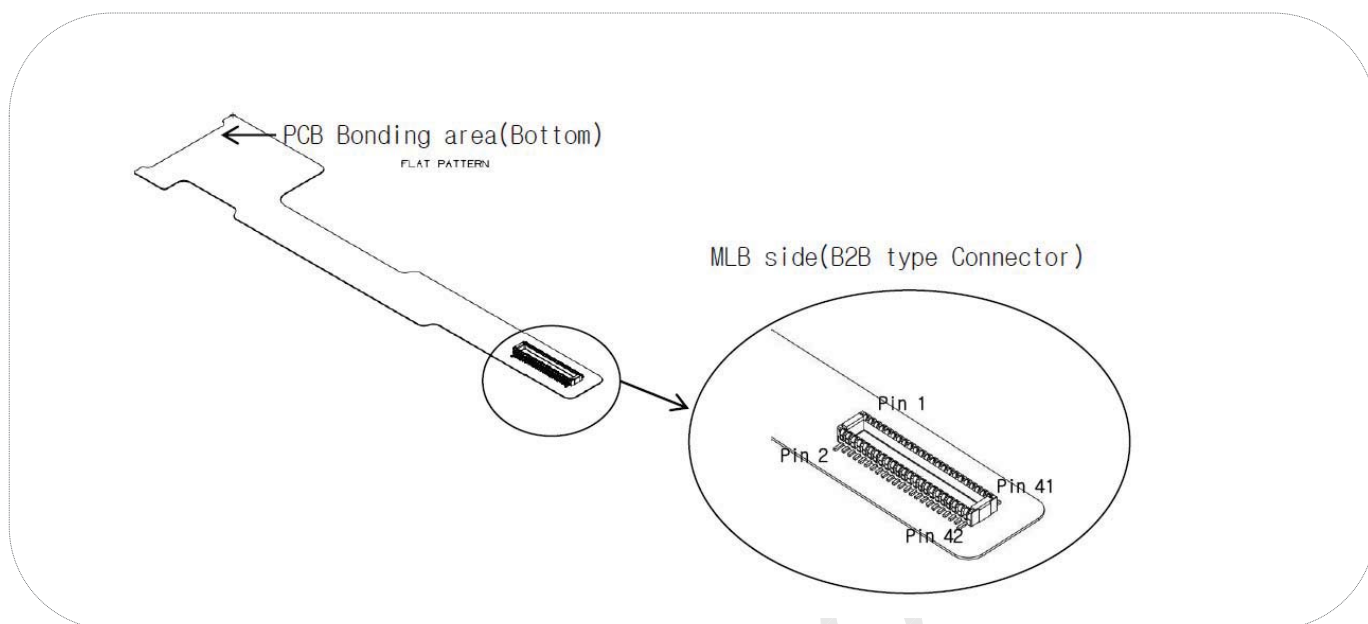

Note:

1. NC: No Connection.
2. All GND(ground) pins should be connected together and to Vss which should also be connected to the LCD's metal frame.
3. All VLCD (power input) pins should be connected together.

Product Specification

Table 4. BACKLIGHT CONNECTOR PIN CONFIGURATION(CN2)

The LED interface connector is a model TF13-18S-0.4H (18pin, 0.4pitch) manufactured by Hirose .
 The pin configuration for the connector is shown in the table below.

A)CNT2

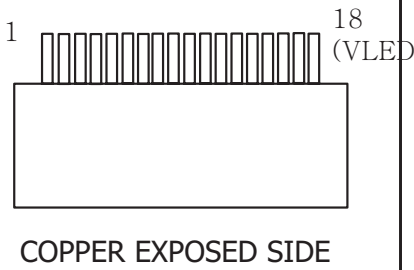
Pin	Symbol	Description	Notes
1	LED Cathode 1A	LED Cathode (Negative)	
2	LED Cathode 2A	LED Cathode (Negative)	
3	LED Cathode 3A	LED Cathode (Negative)	
4	LED Cathode 4A	LED Cathode (Negative)	
5	LED Cathode 5A	LED Cathode (Negative)	
6	LED Cathode 6A	LED Cathode (Negative)	
7	LED Cathode 1B	LED Cathode (Negative)	
8	LED Cathode 2B	LED Cathode (Negative)	
9	LED Cathode 3B	LED Cathode (Negative)	
10	LED Cathode 4B	LED Cathode (Negative)	
11	LED Cathode 5B	LED Cathode (Negative)	
12	LED Cathode 6B	LED Cathode (Negative)	
13	NC	No Connection	
14	LED Anode 1	LED Anode(Positive)	
15	LED Anode 1	LED Anode(Positive)	
16	NC	No Connection	
17	LED Cathode 2B	LED Cathode (Negative)	
18	LED Cathode 1B	LED Cathode (Negative)	

Product Specification

3-3. LVDS Signal Timing Specifications

3-3-1. Video Timing Diagram

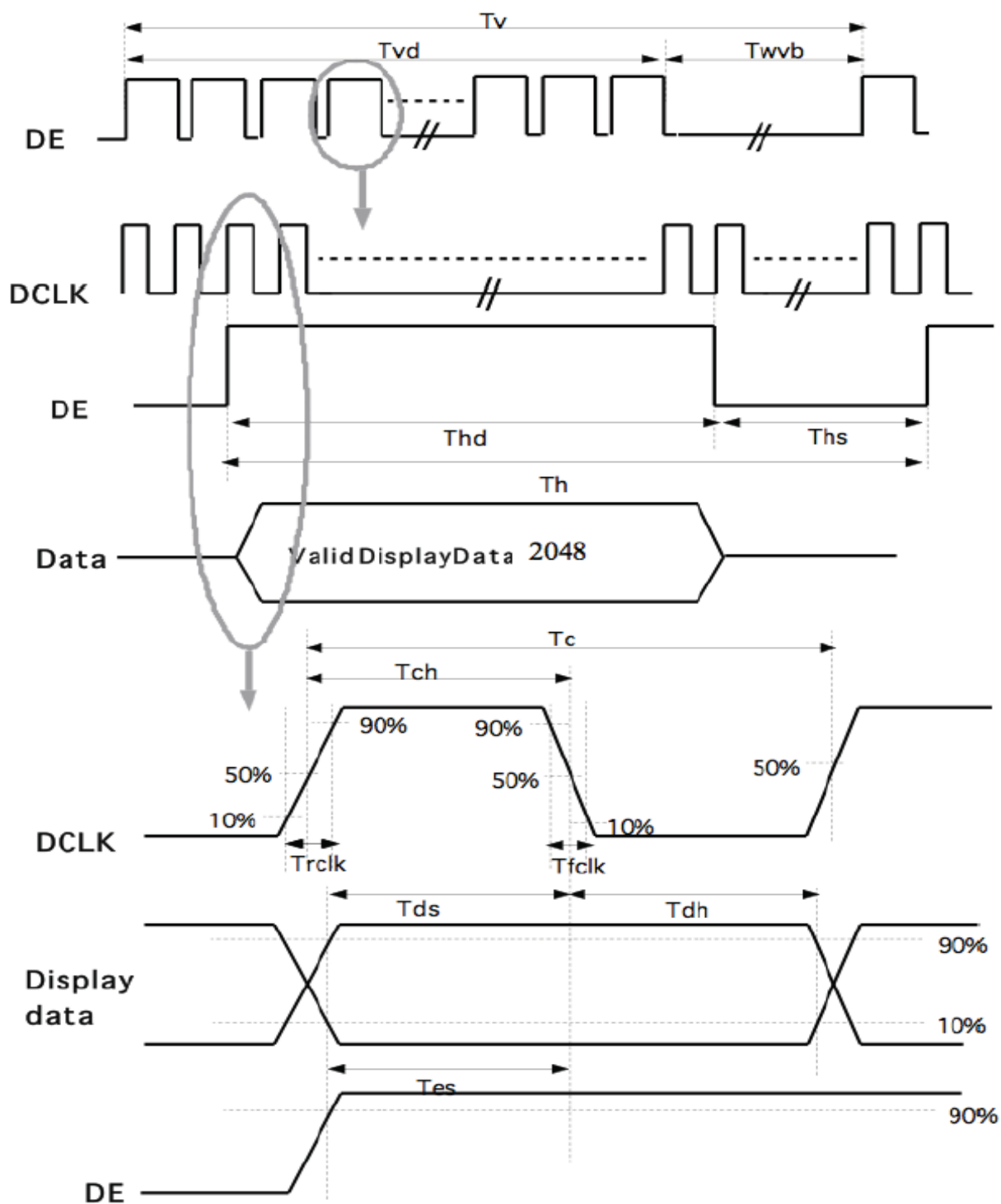

Product Specification

3-4. Signal Timing Specifications

This is the signal timing required at the input of the User connector. All of the interface signal timing should be satisfied with the following specifications and specifications of LVDS Tx/Rx for its proper operation.

Table 6. TIMING TABLE

ITEM	Symbol		Min.	Typ.	Max.	Unit	Note
DCLK	Frequency	f _{CLK}		200		MHz	
Hsync	Active	t _{WHA}		1536		tCLK	
	Period	t _{HP}		1619			
	Width-Active	t _{WH}		15			
Vsync	Active	t _{WVA}		2048		tHP	
	Period	t _{VP}		2059			
	Width-Active	t _{WV}		1			
Data Enable	Horizontal back porch	t _{HBP}		52		tCLK	
	Horizontal front porch	t _{HFP}		16			
	Vertical back porch	t _{VBP}		3		tHP	
	Vertical front porch	t _{VFP}		7			

Product Specification

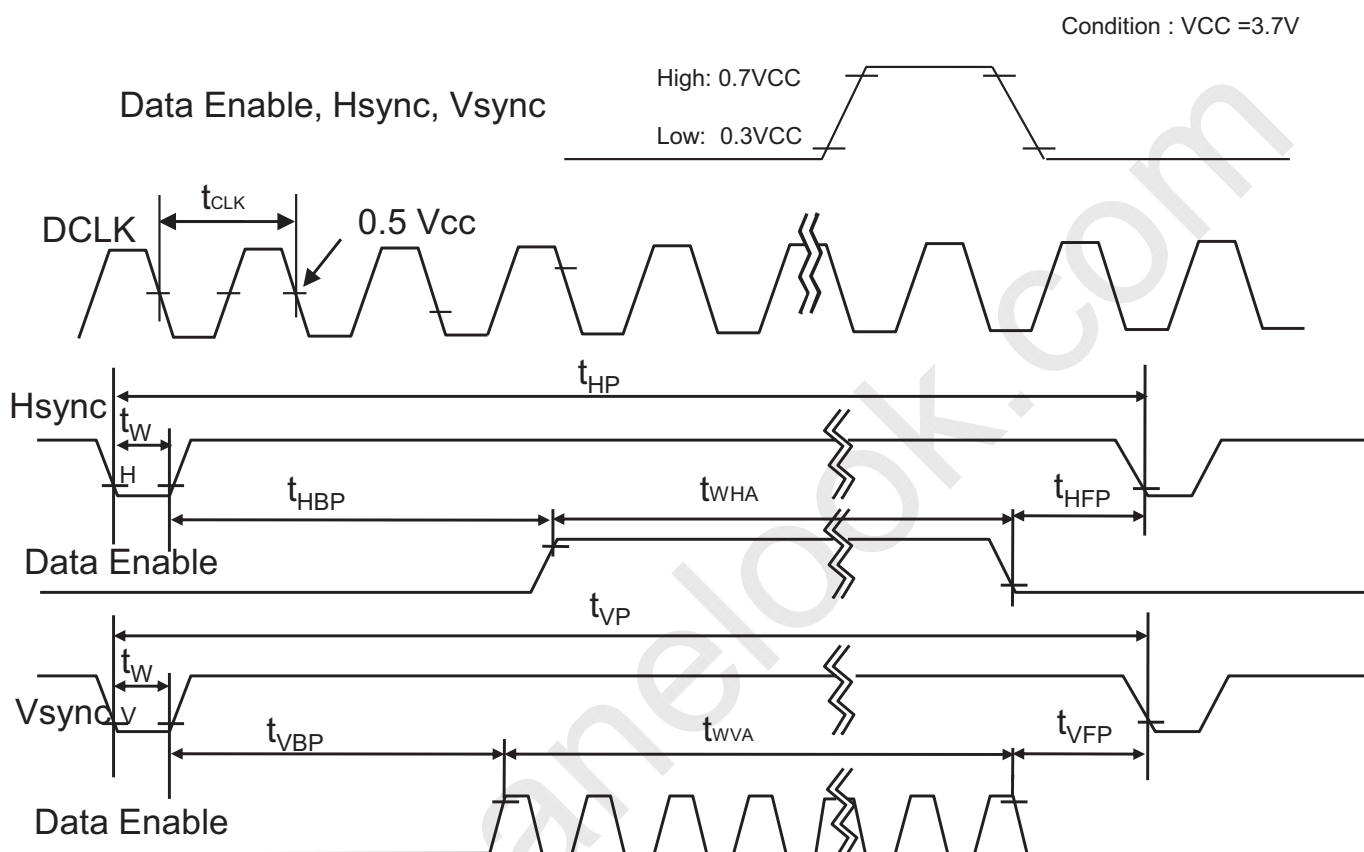
3-5. Signal timing waveforms

Product Specification

3-6. Color Input Data Reference

The brightness of each primary color (red, green and blue) is based on the 8-bit gray scale data input for the color ; the higher the binary input, the brighter the color. The table below provides a reference for color versus data input.

Table 7. COLOR DATA REFERENCE

Color		Input Color Data																							
		RED								GREEN								BLUE							
		MSB				LSB				MSB				LSB				MSB				LSB			
		R7	R6	R5	R4	R3	R2	R1	R0	G7	G6	G5	G4	G3	G2	G1	G0	B7	B6	B5	B4	B3	B2	B1	B0
Basic Color	Black	0	0	0	0	0	0	0	0	0	0	0	0	0	0	0	0	0	0	0	0	0	0	0	0
	Red (255)	1	1	1	1	1	1	1	1	0	0	0	0	0	0	0	0	0	0	0	0	0	0	0	0
	Green (255)	0	0	0	0	0	0	0	0	1	1	1	1	1	1	1	1	0	0	0	0	0	0	0	0
	Blue (255)	0	0	0	0	0	0	0	0	0	0	0	0	0	0	0	0	1	1	1	1	1	1	1	1
	Cyan	0	0	0	0	0	0	0	0	1	1	1	1	1	1	1	1	1	1	1	1	1	1	1	1
	Magenta	1	1	1	1	1	1	1	1	0	0	0	0	0	0	0	0	1	1	1	1	1	1	1	1
	Yellow	1	1	1	1	1	1	1	1	1	1	1	1	1	1	1	1	0	0	0	0	0	0	0	0
	White	1	1	1	1	1	1	1	1	1	1	1	1	1	1	1	1	1	1	1	1	1	1	1	1
RED	RED (000) Dark	0	0	0	0	0	0	0	0	0	0	0	0	0	0	0	0	0	0	0	0	0	0	0	0
	RED (001)	0	0	0	0	0	0	0	1	0	0	0	0	0	0	0	0	0	0	0	0	0	0	0	0
	
	RED (254)	1	1	1	1	1	1	1	0	0	0	0	0	0	0	0	0	0	0	0	0	0	0	0	0
	RED (255)	1	1	1	1	1	1	1	1	0	0	0	0	0	0	0	0	0	0	0	0	0	0	0	0
GREEN	GREEN (000) Dark	0	0	0	0	0	0	0	0	0	0	0	0	0	0	0	0	0	0	0	0	0	0	0	0
	GREEN (001)	0	0	0	0	0	0	0	0	0	0	0	0	0	0	0	1	0	0	0	0	0	0	0	0
	
	GREEN (254)	0	0	0	0	0	0	0	0	1	1	1	1	1	1	1	0	0	0	0	0	0	0	0	0
	GREEN (255)	0	0	0	0	0	0	0	0	1	1	1	1	1	1	1	1	0	0	0	0	0	0	0	0
BLUE	BLUE (000) Dark	0	0	0	0	0	0	0	0	0	0	0	0	0	0	0	0	0	0	0	0	0	0	0	0
	BLUE (001)	0	0	0	0	0	0	0	0	0	0	0	0	0	0	0	0	0	0	0	0	0	0	0	1
	
	BLUE (254)	0	0	0	0	0	0	0	0	0	0	0	0	0	0	0	0	1	1	1	1	1	1	1	0
	BLUE (255)	0	0	0	0	0	0	0	0	0	0	0	0	0	0	0	0	1	1	1	1	1	1	1	1

Product Specification

3-7. Power Sequence

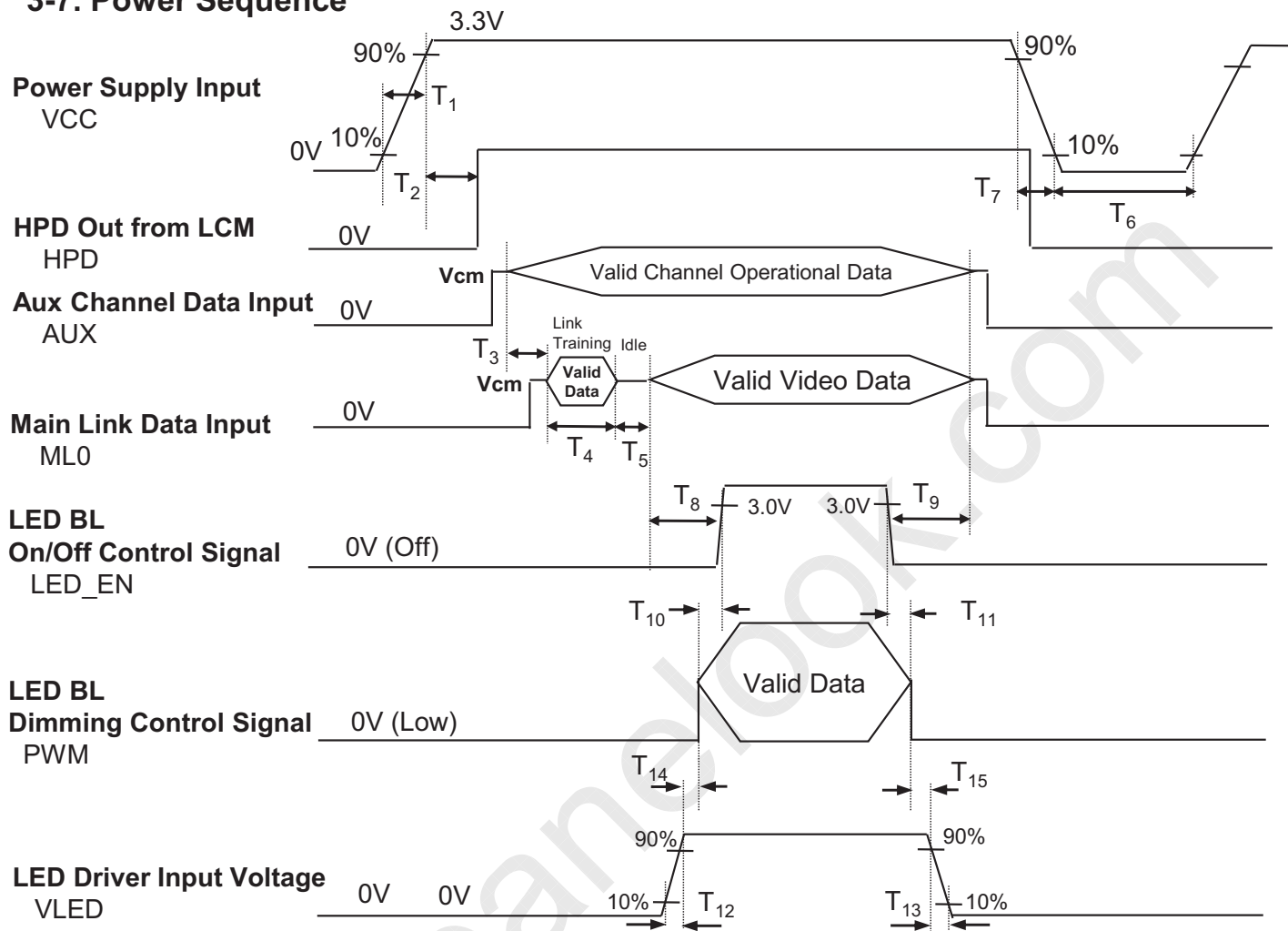

Table 6. POWER SEQUENCE TABLE

Logic Parameter	Value			Units	LED Parameter	Value			Units
	Min.	Typ.	Max.			Min.	Typ.	Max.	
T ₁	0.5	-	10	ms	T ₉	200	-	-	ms
T ₂	0	-	200	ms	T ₁₀	0	-	-	ms
T ₃	50	75	-	ms	T ₁₁	0	-	-	ms
T ₄	0	-	-	ms	T ₁₂	0.5	-	-	ms
T ₅	0	-	-	ms	T ₁₃	0	-	5000	ms
T ₆	500	-	-	ms	T ₁₄	10	-	-	ms
T ₇	3	-	10	ms	T ₁₅	10	-	-	ms
T ₈	200	-	-	ms					

Note)

1. Do not insert the mating cable when system turn on.
2. Valid Data have to meet "3-3. eDP Signal Timing Specifications"
3. LVDS, LED_EN and PWM need to be on pull-down condition on invalid status.
4. LGD recommend the rising sequence of VLED after the Vcc and valid status of LVDS turn on.

Product Specification

4. Optical Specification

Optical characteristics are determined after the unit has been 'ON' and stable for approximately 20 minutes in a dark environment at 25°C. The values specified are at an approximate distance 50cm from the LCD surface at a viewing angle of Φ and Θ equal to 0°.

FIG. 1 presents additional information concerning the measurement equipment and method.

FIG. 1 Optical Characteristic Measurement Equipment and Method

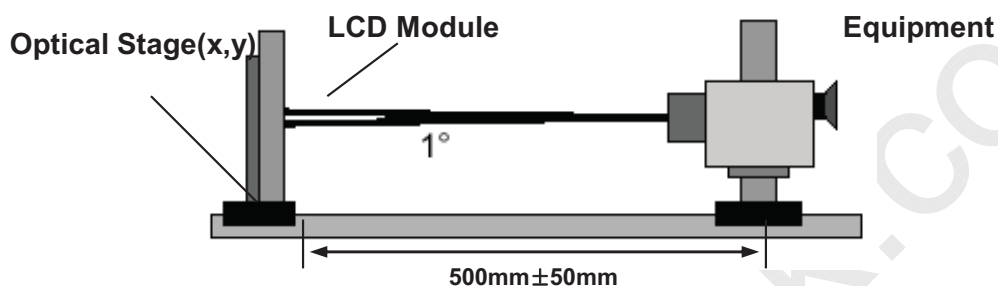

Table 9. OPTICAL CHARACTERISTICS

$T_a=25^\circ\text{C}$, $V_{CC}=3.3\text{V}$, $f_v=60\text{Hz}$, $f_{CLK}=200\text{MHz}$, $I_{LED}=17.5\text{mA}$

Parameter	Symbol	Condition	Min	Typ	Max	Units	Notes	
Average Luminance	L_{AVE}	5 Points (ILED= 17.5mA)	370	440	-	cd/m ²	2	
Luminance variation	δ_{WHITE}	13 points	-	1.4	1.6	%	3	
C/R	-	Center 1 Point	600	800	-	-	1	
Response time		-	-	30	50	ms	4	
Viewing angle	Horizontal	Θ	$\phi_x(\text{Left,Right})$	± 80	± 89	-	°	5
	Vertical	Θ	$\phi_{yu}(\text{Up})$	80	89	-		
		Θ	$\phi_{yd}(\text{Down})$	80	89	-		
Color Coordinates	RED	RX	0.610	0.640	0.670			
		RY	0.300	0.330	0.360			
	GREEN	GX	0.270	0.300	0.330			
		GY	0.570	0.600	0.630			
	BLUE	BX	0.120	0.150	0.180			
		BY	0.030	0.060	0.090			
	WHITE	WX	0.2756	0.3056	0.3356			
		WY	0.2893	0.3193	0.3493			
Cross Talk	DSHA	-	-	-	4.0	%	Fig.5	
Gray Scale	-	-	Gamma 2.2				6	

Product Specification

Note)

1. Contrast Ratio(CR) is defined mathematically as

$$\text{Contrast Ratio} = \frac{\text{Surface Luminance with all white pixels}}{\text{Surface Luminance with all black pixels}}$$

2. Surface luminance is the average of 5 point across the LCD surface 50cm from the surface with all pixels displaying white. For more information see FIG 1.

$$L_{WH} = \text{Average}(L_1, L_2, \dots L_5)$$

3. The variation in surface luminance, The panel total variation (
- δ_{WHITE}
-) is determined by measuring
- L_N
- at each test position 1 through 13 and then defined as followed numerical formula.
-
- For more information see FIG 2.

$$\delta_{WHITE} = \frac{\text{Maximum}(L_1, L_2, \dots L_{13})}{\text{Minimum}(L_1, L_2, \dots L_{13})}$$

4. Response time is the time required for the display to transition from white to black (rise time,
- Tr_R
-) and from black to white(Decay Time,
- Tr_D
-). For additional information see FIG 3.
-
5. Viewing angle is the angle at which the contrast ratio is greater than 10. The angles are determined for the horizontal or x axis and the vertical or y axis with respect to the z axis which is normal to the LCD surface. For more information see FIG 4.
-
6. Gray scale specification
- * $f_v = 60\text{Hz}$

Gray Level	Luminance [%] (Typ)
L0	0.12
L7	1.00
L15	4.30
L23	9.80
L31	19.2
L39	34.2
L47	53.5
L55	74.5
L63	100

Product Specification

FIG. 2 Luminance

<Measuring point for Average Luminance & measuring point for Luminance variation>

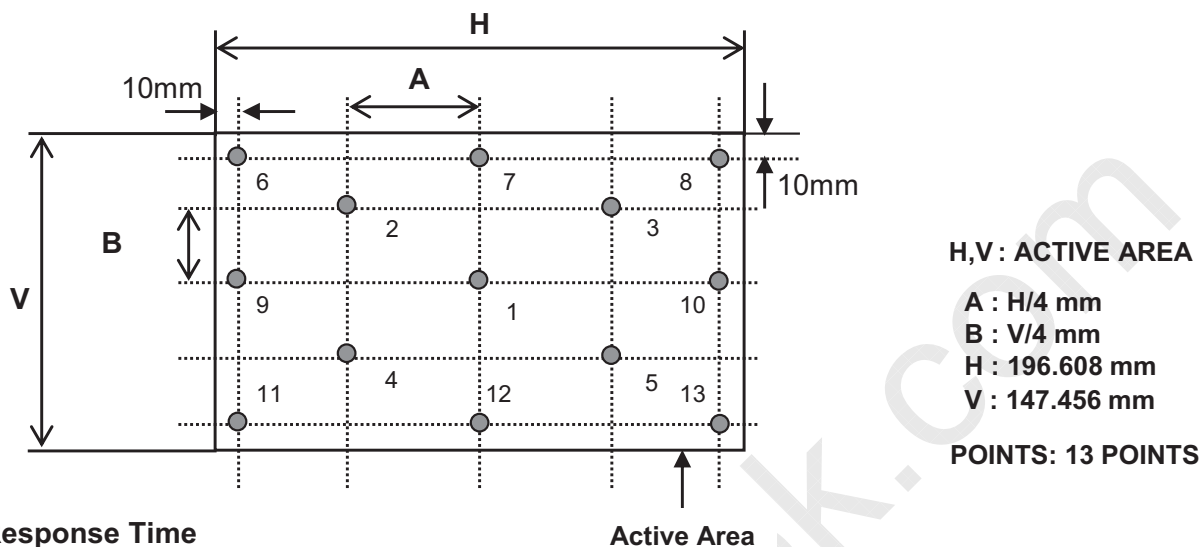

FIG. 3 Response Time

The response time is defined as the following figure and shall be measured by switching the input signal for "black" and "white".

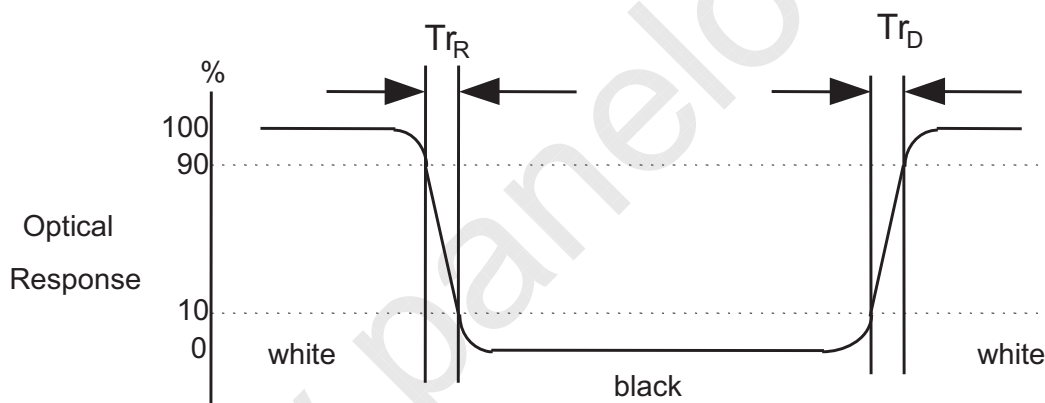
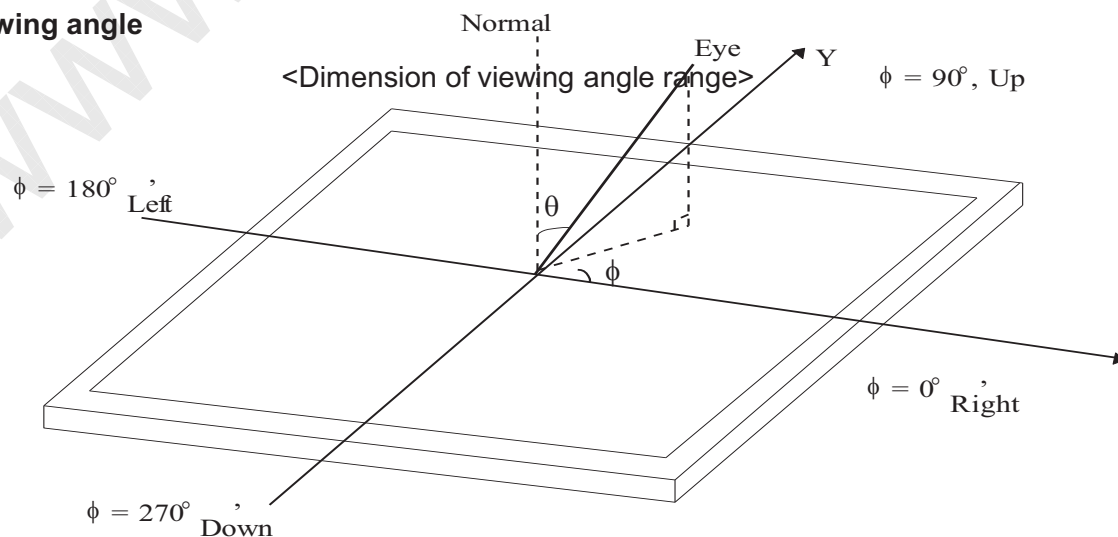

FIG. 4 Viewing angle



Product Specification

FIG. 5 Cross talk

No visual cross-talk will be allowed. Two luminance values are measured at center spot with 50 x 50 pixels. The cross-talk, D_{SHA} , is defined as,

$$D_{SHA} = (L_B - L_A) / L_B \cdot 100\%$$

Where, L_A = Luminance in Pattern A

L_B = Luminance in Pattern B.

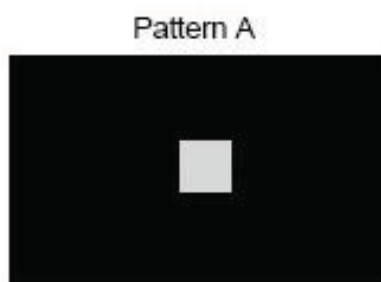

Pattern A
 Gray Scale = 31 in center
 Black in surrounding area

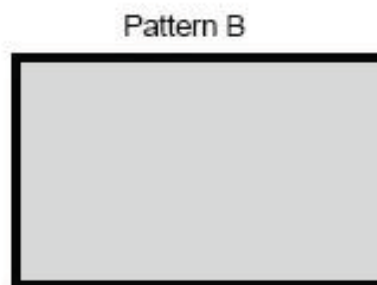

Pattern B
 Gray Scale = 31 full screen

5. Mechanical Characteristics

The contents provide general mechanical characteristics for the model LP097QX2. In addition the figures in the next page are detailed mechanical drawing of the LCD.

Outline Dimension	Horizontal	160.31 ± 0.30mm
	Vertical	208.93 ± 0.30mm
	Thickness	2.34mm(Max.)
Bezel Area	Horizontal	151.49 ± 0.15mm(POL)
	Vertical	200.62 ± 0.15mm(POL)
Active Display Area	Horizontal	147.45mm
	Vertical	196.58mm
Weight	112g (Max.)	
Surface Treatment	Hard coating(2H), Glare treatment of the front Polarizer (Haze 0%)	

Product Specification

<FRONT VIEW>

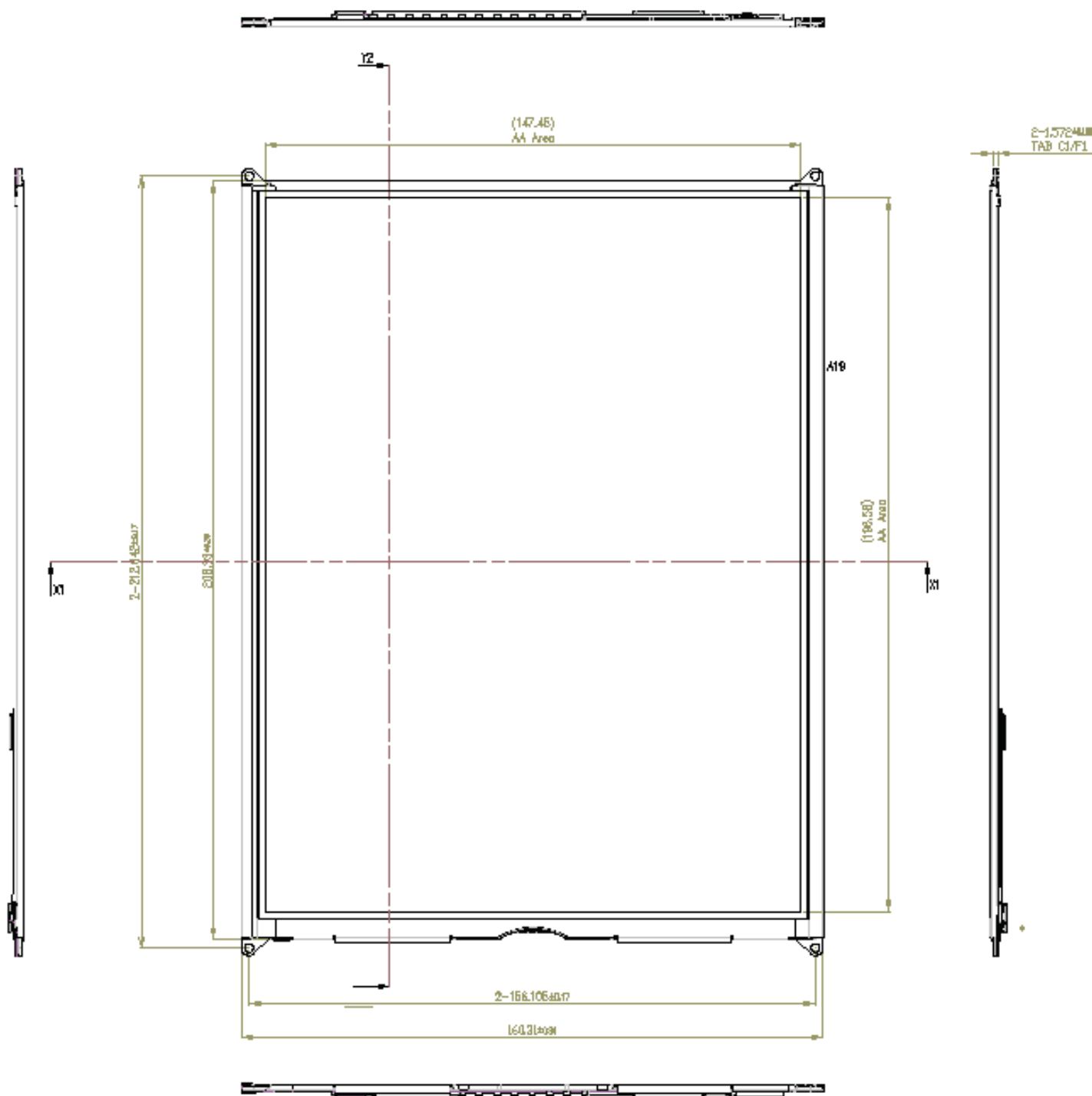



LP097QX2
Liquid Crystal Display

Product Specification

<REAR VIEW>

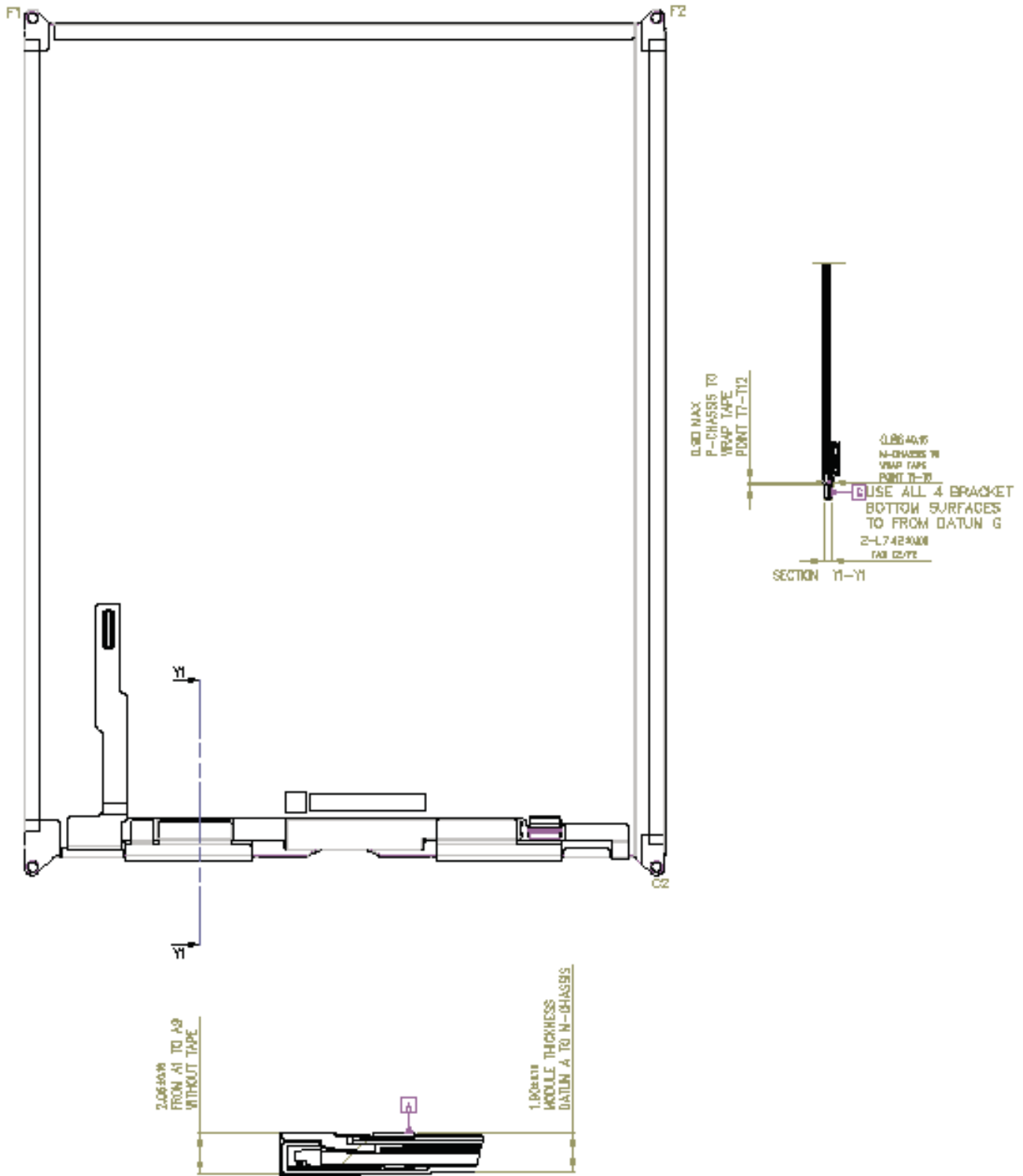

Product Specification

6. Reliability

Environment test condition

No.	Test Item	Conditions
1	High temperature storage test	Ta= 60°C, 240h
2	Low temperature storage test	Ta= -20°C, 240h
3	High temperature operation test	Ta= 50°C, 50%RH, 240h
4	Low temperature operation test	Ta= 0°C, 240h
5	Vibration test (non-operating)	Sine wave, 10 ~ 500 ~ 10Hz, 1.5G, 0.37oct/min 3 axis, 1hour/axis
6	Shock test (non-operating)	Half sine wave, 180G, 2ms one shock of each six faces(I.e. run 180G 6ms for all six faces)
7	Altitude operating storage / shipment	0 ~ 10,000 feet (3,048m) 24Hr 0 ~ 40,000 feet (12,192m) 24Hr

{ Result Evaluation Criteria }

There should be no change which might affect the practical display function when the display quality test is conducted under normal operating condition.

Product Specification

7. International Standards

7-1. Safety

- a) UL 60950-1:2003, First Edition, Underwriters Laboratories, Inc., Standard for Safety of Information Technology Equipment.
- b) CAN/CSA C22.2, No. 60950-1-03 1st Ed. April 1, 2003, Canadian Standards Association, Standard for Safety of Information Technology Equipment.
- c) EN 60950-1:2001, First Edition, European Committee for Electrotechnical Standardization(CENELEC) European Standard for Safety of Information Technology Equipment.

7-2. EMC

- a) ANSI C63.4 "Methods of Measurement of Radio-Noise Emissions from Low-Voltage Electrical and Electrical Equipment in the Range of 9kHz to 40GHz." American National Standards Institute(ANSI), 1992
- b) C.I.S.P.R "Limits and Methods of Measurement of Radio Interface Characteristics of Information Technology Equipment." International Special Committee on Radio Interference.
- c) EN 55022 "Limits and Methods of Measurement of Radio Interface Characteristics of Information Technology Equipment." European Committee for Electrotechnical Standardization.(CENELEC), 1998 (Including A1: 2000)

Product Specification

8. Packing

8-1. Designation of Lot Mark

a) Lot Mark

A	B	C	D	E	F	G	H	I	J	K	L	M
---	---	---	---	---	---	---	---	---	---	---	---	---

A,B,C : SIZE(INCH)
E : MONTH

D : YEAR
F ~ M : SERIAL NO.

Note

1. YEAR

Year	2001	2002	2003	2004	2005	2006	2007	2008	2009	2010
Mark	1	2	3	4	5	6	7	8	9	0

2. MONTH

Month	Jan	Feb	Mar	Apr	May	Jun	Jul	Aug	Sep	Oct	Nov	Dec
Mark	1	2	3	4	5	6	7	8	9	A	B	C

b) Location of Lot Mark

Serial No. is printed on the label. The label is attached to the backside of the LCD module.
This is subject to change without prior notice.

8-2. Packing Form

a) Package quantity in one box : 30 pcs

b) Box Size : 478mm × 365mm × 288mm

Product Specification

9. PRECAUTIONS

Please pay attention to the followings when you use this TFT LCD module.

9-1. MOUNTING PRECAUTIONS

- (1) You must mount a module using holes arranged in four corners or four sides.
- (2) You should consider the mounting structure so that uneven force (ex. Twisted stress) is not applied to the module. And the case on which a module is mounted should have sufficient strength so that external force is not transmitted directly to the module.
- (3) Please attach the surface transparent protective plate to the surface in order to protect the polarizer. Transparent protective plate should have sufficient strength in order to resist external force.
- (4) You should adopt radiation structure to satisfy the temperature specification.
- (5) Acetic acid type and chlorine type materials for the cover case are not desirable because the former generates corrosive gas of attacking the polarizer at high temperature and the latter causes circuit break by electro-chemical reaction.
- (6) Do not touch, push or rub the exposed polarizers with glass, tweezers or anything harder than HB pencil lead. And please do not rub with dust clothes with chemical treatment. Do not touch the surface of polarizer for bare hand or greasy cloth.(Some cosmetics are detrimental to the polarizer.)
- (7) When the surface becomes dusty, please wipe gently with absorbent cotton or other soft materials like chamois soaks with petroleum benzene. Normal-hexane is recommended for cleaning the adhesives used to attach front / rear polarizers. Do not use acetone, toluene and alcohol because they cause chemical damage to the polarizer.
- (8) Wipe off saliva or water drops as soon as possible. Their long time contact with polarizer causes deformations and color fading.
- (9) Do not open the case because inside circuits do not have sufficient strength.

9-2. OPERATING PRECAUTIONS

- (1) The spike noise causes the mis-operation of circuits. It should be lower than following voltage :
 $V = \pm 200\text{mV}$ (Over and under shoot voltage)
- (2) Response time depends on the temperature.(In lower temperature, it becomes longer.)
- (3) Brightness depends on the temperature. (In lower temperature, it becomes lower.)
And in lower temperature, response time(required time that brightness is stable after turned on) becomes longer.
- (4) Be careful for condensation at sudden temperature change. Condensation makes damage to polarizer or electrical contacted parts. And after fading condensation, smear or spot will occur.
- (5) When fixed patterns are displayed for a long time, remnant image is likely to occur.
- (6) Module has high frequency circuits. Sufficient suppression to the electromagnetic interference shall be done by system manufacturers. Grounding and shielding methods may be important to minimize the interference.

9-3. ELECTROSTATIC DISCHARGE CONTROL

Since a module is composed of electronic circuits, it is not strong to electrostatic discharge. Make certain that treatment persons are connected to ground through wrist band etc. And don't touch interface pin directly.

9-4. PRECAUTIONS FOR STRONG LIGHT EXPOSURE

Strong light exposure causes degradation of polarizer and color filter.

9-5. STORAGE

When storing modules as spares for a long time, the following precautions are necessary.

- (1) Store them in a dark place. Do not expose the module to sunlight or fluorescent light. Keep the temperature between 5°C and 35°C at normal humidity.
- (2) The polarizer surface should not come in contact with any other object.
It is recommended that they be stored in the container in which they were shipped.

9-6. HANDLING PRECAUTIONS FOR PROTECTION FILM

- (1) When the protection film is peeled off, static electricity is generated between the film and polarizer. This should be peeled off slowly and carefully by people who are electrically grounded and with well ion-blown equipment or in such a condition, etc.
- (2) The protection film is attached to the polarizer with a small amount of glue. If some stress is applied to rub the protection film against the polarizer during the time you peel off the film, the glue is apt to remain on the polarizer.
Please carefully peel off the protection film without rubbing it against the polarizer.
- (3) When the module with protection film attached is stored for a long time, sometimes there remains a very small amount of glue still on the polarizer after the protection film is peeled off.
- (4) You can remove the glue easily. When the glue remains on the polarizer surface or its vestige is recognized, please wipe them off with absorbent cotton waste or other soft material like chamois soaked with normal-hexane.

Product Specification

APPENDIX A. Enhanced Extended Display Identification Data (EEDID™) 1/4

	Byte (Dec)	Byte (Hex)	Field Name and Comments	Value (Hex)	Value (Bin)
Header	0	00	Header	00	00000000
	1	01	Header	FF	11111111
	2	02	Header	FF	11111111
	3	03	Header	FF	11111111
	4	04	Header	FF	11111111
	5	05	Header	FF	11111111
	6	06	Header	FF	11111111
	7	07	Header	00	00000000
Vendor / Product EDID Version	8	08	EISA manufacture code (3 Character ID) ETC	16	00010110
	9	09	EISA manufacture code (Compressed ASCII)	83	10000011
	10	0A	Panel Supplier Reserved - Product Code 0000h	00	00000000
	11	0B	(Hex. LSB first)	00	00000000
	12	0C	LCD Module Serial No - Preferred but Optional ("0" If not used)	00	00000000
	13	0D	LCD Module Serial No - Preferred but Optional ("0" If not used)	00	00000000
	14	0E	LCD Module Serial No - Preferred but Optional ("0" If not used)	00	00000000
	15	0F	LCD Module Serial No - Preferred but Optional ("0" If not used)	00	00000000
	16	10	Week of Manufacture 26 weeks	1A	00011010
	17	11	Year of Manufacture 2012 years	16	00010110
Display Parameters	18	12	EDID structure version # = 1	01	00000001
	19	13	EDID revision # = 4	04	00000100
	20	14	Video input Definition = Digital signal	A5	10100101
	21	15	Max H image size (Rounded cm) = 15cm	0F	00001111
Panel Color Coordinates	22	16	Max V image size (Rounded cm) = 20cm	14	00010100
	23	17	Display gamma = (gamma*100)-100 = Example:(2.2*100)-100=120 = 2.2 Gamma	78	01111000
	24	18	Feature Support (no_DPMS, no_Active Off/Very Low Power, RGB color display, Timing BLK 1,no_GTF)	06	00000110
	25	19	Red/Green Low Bits (RxRy/GxGy)	EF	11101111
	26	1A	Blue/White Low Bits (BxBY/WxWy)	05	00000101
	27	1B	Red X Rx = 0.640	A3	10100011
	28	1C	Red Y Ry = 0.330	54	01010100
	29	1D	Green X Gx = 0.300	4C	01001100
	30	1E	Green Y Gy = 0.600	99	10011001
	31	1F	Blue X Bx = 0.150	26	00100110
Established Timings	32	20	Blue Y By = 0.060	0F	00001111
	33	21	White X Wx = 0.313	50	01010000
	34	22	White Y Wy = 0.329	54	01010100
	35	23	Established timing 1 (00h if not used)	00	00000000
Standard Timing ID	36	24	Established timing 2 (00h if not used)	00	00000000
	37	25	Manufacturer's timings (00h if not used)	00	00000000
	38	26	Standard timing ID1 (01h if not used)	01	00000001
	39	27	Standard timing ID1 (01h if not used)	01	00000001
	40	28	Standard timing ID2 (01h if not used)	01	00000001
	41	29	Standard timing ID2 (01h if not used)	01	00000001
	42	2A	Standard timing ID3 (01h if not used)	01	00000001
	43	2B	Standard timing ID3 (01h if not used)	01	00000001
	44	2C	Standard timing ID4 (01h if not used)	01	00000001
	45	2D	Standard timing ID4 (01h if not used)	01	00000001
	46	2E	Standard timing ID5 (01h if not used)	01	00000001
	47	2F	Standard timing ID5 (01h if not used)	01	00000001
	48	30	Standard timing ID6 (01h if not used)	01	00000001
	49	31	Standard timing ID6 (01h if not used)	01	00000001
	50	32	Standard timing ID7 (01h if not used)	01	00000001
	51	33	Standard timing ID7 (01h if not used)	01	00000001
	52	34	Standard timing ID8 (01h if not used)	01	00000001
	53	35	Standard timing ID8 (01h if not used)	01	00000001

Product Specification

APPENDIX A. Enhanced Extended Display Identification Data (EEDID™) 2/4

	Byte (Dec)	Byte (Hex)	Field Name and Comments	Value (Hex)	Value (Bin)
Timing Descriptor #1	54	36	Pixel Clock/10,000 (LSB) 200 MHz @ 60MHz	20	00100000
	55	37	Pixel Clock/10,000 (MSB)	4E	01001110
	56	38	Horizontal Active (lower 8 bits) 1536 Pixels	00	00000000
	57	39	Horizontal Blanking(Thp-HA) (lower 8 bits) 83 Pixels	53	01010011
	58	3A	Horizontal Active / Horizontal Blanking(Thp-HA) (upper 4:4bits)	60	01100000
	59	3B	Vertical Active 2048 Lines	00	00000000
	60	3C	Vertical Blanking (Tvp-HA) (DE Blanking typ.for DE only panels) 11 Lines	0B	00001011
	61	3D	Vertical Active : Vertical Blanking (Tvp-HA) (upper 4:4bits)	80	10000000
	62	3E	Horizontal Sync. Offset (Thfp) 16 Pixels	10	00010000
	63	3F	Horizontal Sync Pulse Width (HSPW) 15 Pixels	0F	00001111
	64	40	Vertical Sync Offset(Tvfp) : Sync Width (VSPW) 7 Lines : 1 Lines	71	01110001
	65	41	Horizontal Vertical Sync Offset/Width (upper 2bits)	00	00000000
	66	42	Horizontal Image Size 148 (mm)	94	10010100
	67	43	Vertical Image Size 197 (mm)	C5	11000101
	68	44	Horizontal Image Size / Vertical Image Size	00	00000000
	69	45	Horizontal Border = 0 (Zero for Notebook LCD)	00	00000000
	70	46	Vertical Border = 0 (Zero for Notebook LCD)	00	00000000
71	47	Non-Interlace, Normal display, no stereo, Digital Separate (Vsync_NEG, Hsync_NEG)	18	00011000	
Timing Descriptor #2	72	48	Flag	00	00000000
	73	49	Flag	00	00000000
	74	4A	Flag	00	00000000
	75	4B	Data Type Tag (Descriptor Defined by manufacturer)	10	00010000
	76	4C	Flag	00	00000000
	77	4D	Descriptor Defined by manufacturer	00	00000000
	78	4E	Descriptor Defined by manufacturer	00	00000000
	79	4F	Descriptor Defined by manufacturer	00	00000000
	80	50	Descriptor Defined by manufacturer	00	00000000
	81	51	Descriptor Defined by manufacturer	00	00000000
	82	52	Descriptor Defined by manufacturer	00	00000000
	83	53	Descriptor Defined by manufacturer	00	00000000
	84	54	Descriptor Defined by manufacturer	00	00000000
	85	55	Descriptor Defined by manufacturer	00	00000000
	86	56	Descriptor Defined by manufacturer	00	00000000
	87	57	Descriptor Defined by manufacturer	00	00000000
	88	58	(If<13 char--> 0Ah, then terminate with ASC II code 0Ah,set remaining char = 20h)	00	00000000
	89	59	(If<13 char--> 0Ah, then terminate with ASC II code 0Ah,set remaining char = 20h)	00	00000000
	Timing Descriptor #3	90	5A	Flag	00
91		5B	Flag	00	00000000
92		5C	Flag	00	00000000
93		5D	Data Type Tag (ASCII String)	FE	11111110
94		5E	Flag	00	00000000
95		5F	ASCII String L	4C	01001100
96		60	ASCII String P	50	01010000
97		61	ASCII String 0	30	00110000
98		62	ASCII String 9	39	00111001
99		63	ASCII String 7	37	00110111
100		64	ASCII String Q	51	01010001
101		65	ASCII String X	58	01011000
102		66	ASCII String 2	32	00110010
103		67	ASCII String -	2D	00101101
104		68	ASCII String S	53	01010011
105		69	ASCII String P	50	01010000
106		6A	ASCII String A	41	01000001
107	6B	ASCII String V	56	01010110	

Product Specification

APPENDIX A. Enhanced Extended Display Identification Data (EEDID™) 3/4

	Byte (Dec)	Byte (Hex)	Field Name and Comments		Value (Bin)
Timing Descriptor #4	108	6C	Flag	00	00000000
	109	6D	Flag	00	00000000
	110	6E	Flag	00	00000000
	111	6F	Data Type Tag (ASCII String)	FC	11111100
	112	70	Flag	00	00000000
	113	71	ASCII String C	43	01000011
	114	72	ASCII String O	6F	01101111
	115	73	ASCII String L	6C	01101100
	116	74	ASCII String O	6F	01101111
	117	75	ASCII String R	72	01110010
	118	76	ASCII String SPACE	20	00100000
	119	77	ASCII String L	4C	01001100
	120	78	ASCII String C	43	01000011
	121	79	ASCII String D	44	01000100
	122	7A	(If<13 char--> 0Ah, then terminate with ASCII code 0Ah,set remaining char = 20h)	0A	00001010
123	7B	(If<13 char--> 0Ah, then terminate with ASCII code 0Ah,set remaining char = 20h)	20	00100000	
124	7C	(If<13 char--> 0Ah, then terminate with ASCII code 0Ah,set remaining char = 20h)	20	00100000	
125	7D	(If<13 char--> 0Ah, then terminate with ASCII code 0Ah,set remaining char = 20h)	20	00100000	
Checksum	126	7E	Extension flag (# of optional 255 panel ID extension block to follow, Typ = 0)	00	00000000
	127	7F	Check Sum (The 1-byte sum of all 255 bytes in this panel ID block shall = 0)	A8	10101000



LP097QX2
Liquid Crystal Display

Product Specification

APPENDIX A. Enhanced Extended Display Identification Data (EEDID™) 4/4

Byte (Dec)	Byte (Hex)	Field Name and Comments	Value (Hex)	Value (Bin)
128	80		00	00000000
129	81		00	00000000
130	82		00	00000000
131	83		00	00000000
132	84		00	00000000
133	85		00	00000000
134	86		00	00000000
135	87		00	00000000
136	88		00	00000000
137	89		00	00000000
138	8A		00	00000000
139	8B		00	00000000
140	8C		00	00000000
141	8D		00	00000000
142	8E		00	00000000
143	8F		00	00000000
144	90		00	00000000
145	91		00	00000000
146	92		00	00000000
147	93		00	00000000
148	94		00	00000000
149	95		00	00000000
150	96		00	00000000
151	97		00	00000000
152	98		00	00000000
153	99		00	00000000
154	9A		00	00000000
155	9B		00	00000000
156	9C		00	00000000
157	9D		00	00000000
158	9E		00	00000000
159	9F		00	00000000
160	A0		00	00000000
161	A1		00	00000000
162	A2		00	00000000
163	A3		00	00000000
164	A4		00	00000000
165	A5		00	00000000
166	A6		00	00000000
167	A7		00	00000000
168	A8		00	00000000
169	A9		00	00000000
170	AA		00	00000000
171	AB		00	00000000
172	AC		00	00000000
173	AD		00	00000000
174	AE		00	00000000
175	AF		00	00000000
176	B0		00	00000000
177	B1		00	00000000
178	B2		00	00000000
179	B3		00	00000000
180	B4		00	00000000
181	B5		00	00000000
182	B6		00	00000000
183	B7		00	00000000
184	B8		00	00000000
185	B9		00	00000000
186	BA		00	00000000
187	BB		00	00000000
188	BC		00	00000000
189	BD		00	00000000
190	BE		00	00000000
191	BF		00	00000000
192	C0		00	00000000
193	C1		00	00000000
194	C2		00	00000000
195	C3		00	00000000
196	C4		00	00000000
197	C5		00	00000000
198	C6		00	00000000
199	C7		00	00000000
200	C8		00	00000000
201	C9		00	00000000
202	CA		00	00000000
203	CB		00	00000000
204	CC		00	00000000
205	CD		00	00000000
206	CE		00	00000000
207	CF		00	00000000
208	D0		00	00000000
209	D1		00	00000000
210	D2		00	00000000
211	D3		00	00000000
212	D4		00	00000000
213	D5		00	00000000
214	D6		00	00000000
215	D7		00	00000000
216	D8		00	00000000
217	D9		00	00000000
218	DA		00	00000000
219	DB		00	00000000
220	DC		00	00000000
221	DD		00	00000000
222	DE		00	00000000
223	DF		00	00000000
224	E0		00	00000000
225	E1		00	00000000
226	E2		00	00000000
227	E3		00	00000000
228	E4		00	00000000
229	E5		00	00000000
230	E6		00	00000000
231	E7		00	00000000
232	E8		00	00000000
233	E9		00	00000000
234	EA		00	00000000
235	EB		00	00000000
236	EC		00	00000000
237	ED		00	00000000
238	EE		00	00000000
239	EF		00	00000000
240	F0		00	00000000
241	F1		00	00000000
242	F2		00	00000000
243	F3		00	00000000
244	F4		00	00000000
245	F5		00	00000000
246	F6		00	00000000
247	F7		00	00000000
248	F8		00	00000000
249	F9		00	00000000
250	FA		00	00000000
251	FB		00	00000000
252	FC		00	00000000
253	FD		00	00000000
254	FE		00	00000000
255	FF		00	00000000