

Version: 1.0

TECHNICAL SPECIFICATION

MODEL NO: ES103TC1

The content of this information is subject to be changed without notice.
Please contact E Ink or its agent for further information.

Customer's Confirmation

Customer _____

Date _____

By _____

E Ink's Confirmation

Approved By



Confirmed By



Prepared By



Revision History

Rev.	Issued Date	Revised Contents
1.0	2016-11-07	New V1.0 Version

TECHNICAL SPECIFICATION

CONTENTS

1. General Description.....	1
2. Features.....	1
3. Mechanical Specifications.....	1
4. Mechanical Drawing of EPD Module	2
5. Input / Output Interface	3
6. Display Module Electrical Characteristics	5
7. Power Sequence.....	9
8. Optical Characteristics.....	11
9. Handling, Safety and Environmental Requirements and Remark	12
10. Reliability Test	13
11. Border Definition.....	14
12. Block Diagram.....	15
13. Packing	16

1. General Description

ES103TC1 is a reflective electrophoretic E Ink® and Mobius technology display module based on active matrix TFT substrate. It has 10.3” active area with 1404 x 1872 pixels, the display is capable to display images at 2-16 gray levels (1-4 bits) depending on the display controller and the associated waveform file it used.

2. Features

- High contrast reflective/electrophoretic technology
- 1404x 1872 Mobius display
- Ultra wide viewing angle
- Ultra low power consumption
- Pure reflective mode
- Bi-stable
- Commercial temperature range
- Landscape, portrait mode

3. Mechanical Specifications

Parameter	Specifications	Unit	Remark
Screen Size	10.3	Inch	
Display Resolution	1404(H) × 1872(V)	Pixel	
Active Area	157.248(H) × 209.664 (V)	mm	
Pixel Pitch	0.112(H) × 0.112(V)	mm	
Pixel Configuration	Rectangle		
Outline Dimension	165.8(H) × 227.7(V) × 0.67(D)	mm	Panel area height
Module Weight	32 ± 5	g	
Number of Grey	16 Grey Level (monochrome)		
Display operating mode	Reflective mode		
Surface treatment	Anti-glare treatment		

4. Mechanical Drawing of EPD Module

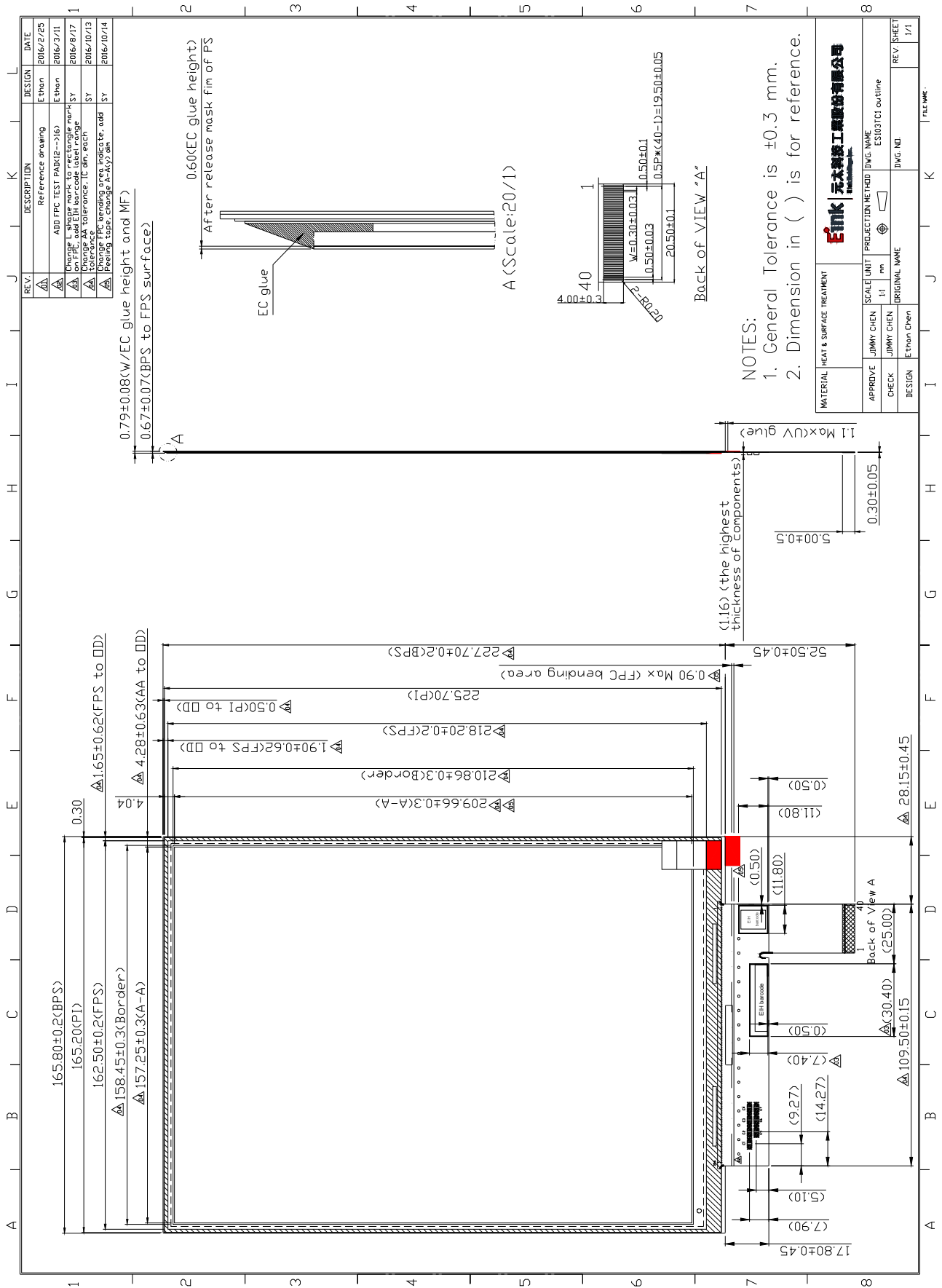

5. Input / Output Interface

5.1 Pin Assignment

Connector type : 196033-40041

Pin #	Signal	Description	Remark
1	VGL	Negative power supply gate driver	
2	NC	NO Connection	
3	VGH	Positive power supply gate driver	
4	NC	NO Connection	
5	VDD	Digital power supply drivers	
6	MODE	Output mode selection gate driver	
7	CKV	Clock gate driver	
8	SPV	Start pulse gate driver	
9	VSS	Ground	
10	VCOM	Common voltage	
11	VDD	Digital power supply drivers	
12	VSS	Ground	
13	XCL	Clock source driver	
14	D0	Data signal source driver	
15	D1	Data signal source driver	
16	D2	Data signal source driver	
17	D3	Data signal source driver	
18	D4	Data signal source driver	
19	D5	Data signal source driver	
20	D6	Data signal source driver	
21	D7	Data signal source driver	
22	VSS	Ground	
23	D8	Data signal source driver	
24	D9	Data signal source driver	
25	D10	Data signal source driver	
26	D11	Data signal source driver	
27	D12	Data signal source driver	
28	D13	Data signal source driver	
29	D14	Data signal source driver	
30	D15	Data signal source driver	
31	XSTL	Start pulse source driver	
32	XLE	Latch enable source driver	
33	XOE	Output enable source driver	
34	NC	NO Connection	

35	NC	NO Connection	
36	VPOS	Positive power supply source driver	
37	NC	NO Connection	
38	VNEG	Negative power supply source driver	
39	NC	NO Connection	
40	Border	Border connection	

5.2 Panel Scan Direction

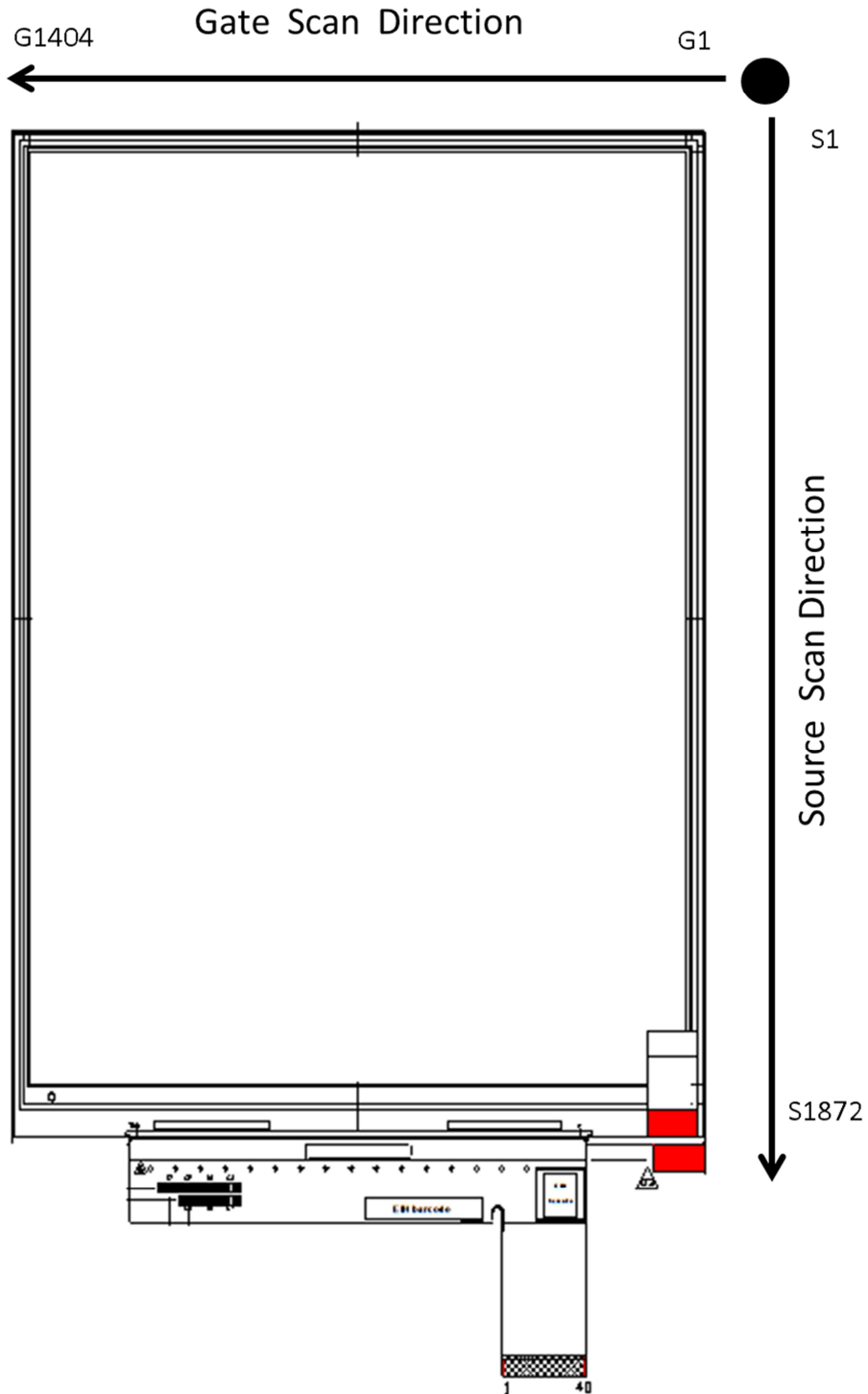

The information contained herein is the exclusive property of E Ink Holdings Inc., and shall not be distributed, reproduced, or disclosed in whole or in part without prior written permission of E Ink Holdings Inc.

6. Display Module Electrical Characteristics

6.1 Absolute Maximum Ratings

Parameter	Symbol	Rating	Unit	Remark
Logic Supply Voltage	V_{DD}	-0.3 to +5	V	
Positive Supply Voltage	V_{POS}	-0.3 to +18	V	
Negative Supply Voltage	V_{NEG}	+0.3 to -18	V	
Max .Drive Voltage Range	$V_{POS} - V_{NEG}$	36	V	
Supply Voltage	V_{GH}	-0.3 to $V_{GL}+50$	V	
Supply Voltage	V_{GL}	-25 to +0.3	V	
Supply Range	$V_{GH}-V_{GL}$	+10 to +50	V	
Operating Temp. Range	T_{OTR}	0 to +50	°C	
Storage Temperature	T_{STG}	-25 to +70	°C	

6.2 Display Module DC Characteristics

Parameter	Symbol	Conditions	Min	Typ	Max	Unit
Signal Ground	V_{SS}		-	0	-	V
Logic Voltage Supply	V_{DD}		3.0	3.3	3.6	V
	I_{DD}	$V_{DD}=3.3V$	-	8.99	19.53	mA
Gate Negative Supply	V_{GL}		-21	-20	-19	V
	I_{GL}	$V_{GL}=-20V$	-	1.38	17.13	mA
Gate Positive supply	V_{GH}		27	28	29	V
	I_{GH}	$V_{GH}=28V$	-	0.88	0.99	mA
Source Negative Supply	V_{NEG}		-15.4	-15	-14.6	V
	I_{NEG}	$V_{NEG}=-15V$	-	1.46	199.14	mA
Source Positive Supply	V_{POS}		14.6	15	15.4	V
	I_{POS}	$V_{POS}=15V$	-	1.44	200.0	mA
Border Supply	V_{COM}		-	Adjusted	-	V
Asymmetry Source	V_{ASM}	$V_{POS}+V_{NEG}$	-800	0	800	mV
Common Voltage	V_{COM}		-	Adjusted	-	V
	I_{COM}		-	0.52	0.76	mA
Power Panel	P		-	126	6480	mW
Standby Power Panel	P_{STBY}		-	-	0.3	mW

- The maximum power consumption is measured using 85Hz waveform with following pattern transition: from pattern of repeated 1 consecutive black scan lines followed by 1 consecutive white scan line to that of repeated 1 consecutive white scan lines followed by 1 consecutive black scan lines (Note 6-1).
- The Typical power consumption is measured using 85Hz waveform with following pattern transition: from horizontal 4 grey scale pattern to vertical 4 grey scale patterns (Note 6-2).
- The standby power is the consumed power when the panel controller is in standby mode.
- The listed electrical/optical characteristics are only guaranteed under the controller & waveform provided by E Ink.
- V_{COM} is recommended to be set in the range of assigned value $\pm 0.1V$
- The maximum I_{COM} inrush current is about 1.61 A

Note6-1

The maximum power consumption

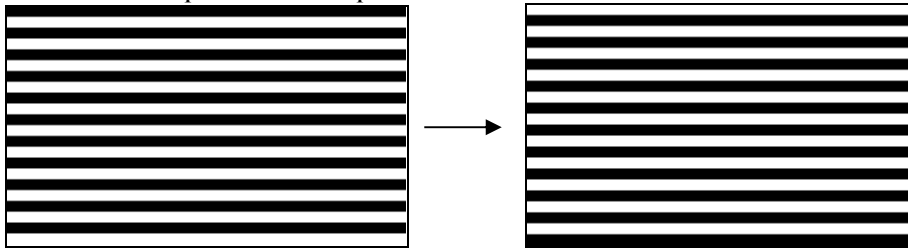

Note6-2

The typical power consumption

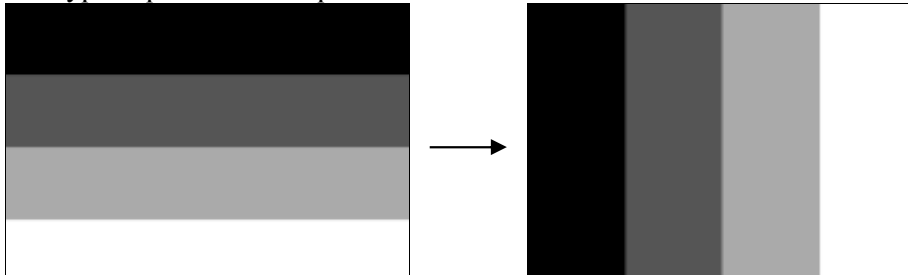

6.3 Display Module AC characteristics

Parameter	Symbol	Min.	Typ.	Max.	Unit
Clock frequency	fckv	-	-	200	kHz
Minimum “L” clock pulse width	twL	500	-	-	ns
Minimum “H” clock pulse width	twH	500	-	-	ns
Clock rise time	trckv	-	-	100	ns
Clock fall time	tfckv	-	-	100	ns
SPV setup time	tSU	100	-	-	ns
SPV hold time	tH	100	-	-	ns
Pulse rise time	trspv	-	-	100	ns
Pulse fall time	tfspv	-	-	100	ns
Clock XCL cycle time	tcy	16.67	50	-	ns
D0 .. D15 setup time	tsu	8	-	-	ns
D0 .. D15 hold time	th	8	-	-	ns
XSTL setup time	tstls	0.5*tcy	-	0.8*tcy	ns
XSTL hold time	tstlh	0.5*tcy	-	240*tcy-tstls	ns
XLE on delay time	tLEdly	10.5*tcy	-	-	ns
XLE high-level pulse width (When V _{DD} =1.7V to 3.6V)	tLEw	300	-	-	ns
XLE off delay time	tLEoff	200	-	-	ns
Output setting time to +/- 30mV(C _{load} =200pF)	tout	-	-	20	us

OUTPUT LATCH CONTROL SIGNALS

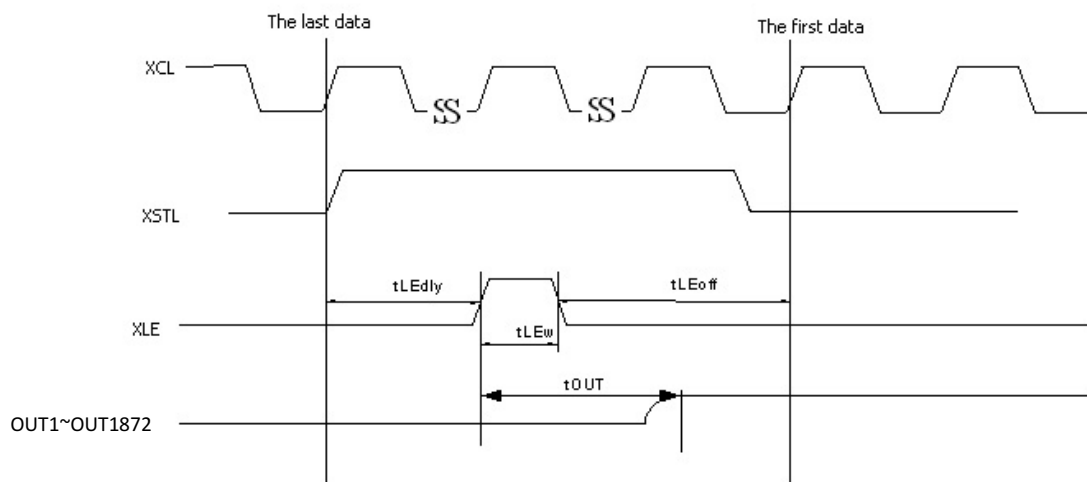

CLOCK & DATA TIMING

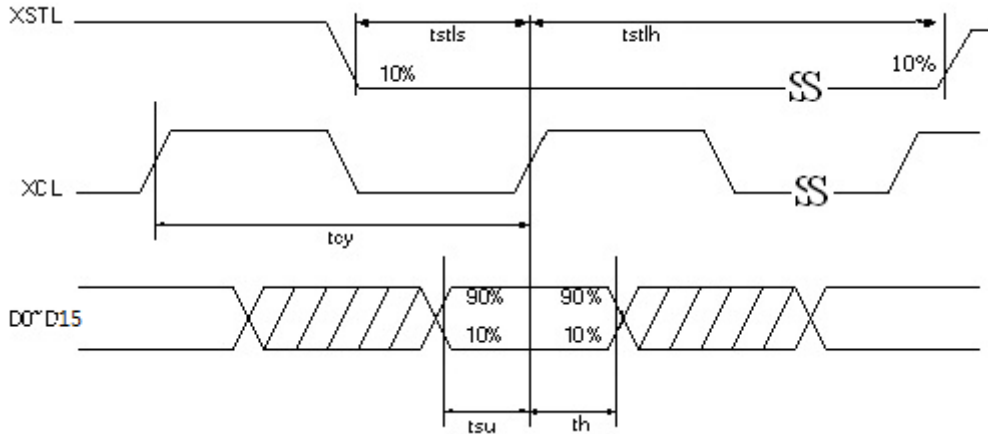

CKV & SPV TIMING

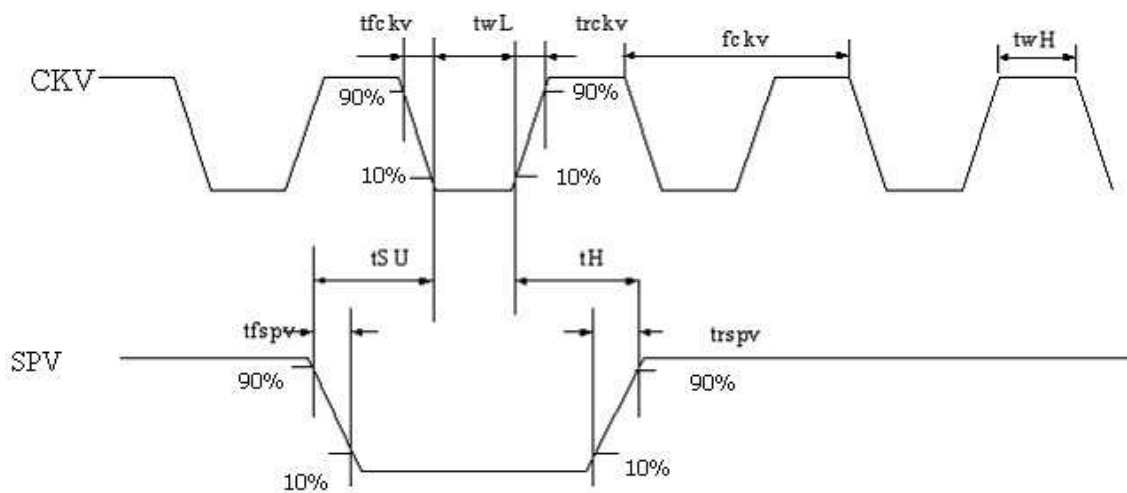

GATE OUTPUT TIMING

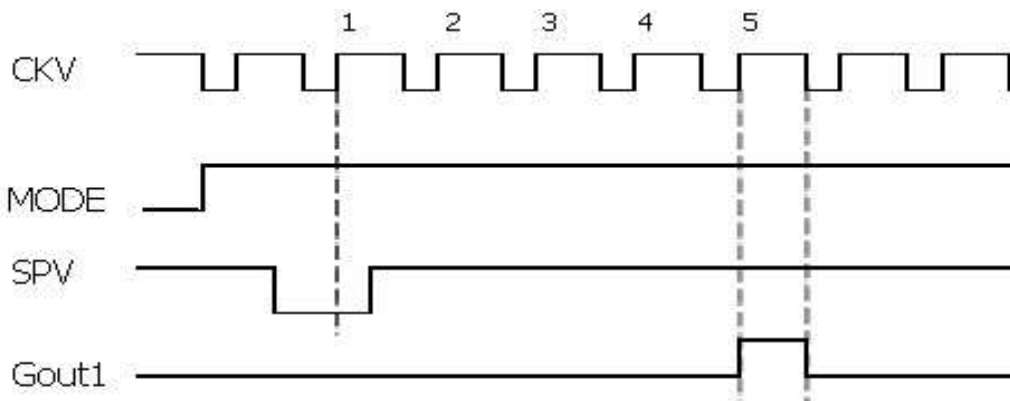

Note : First gate line on timing

6.4 Refresh Rate

The module ES103TC1 is applied at a maximum screen refresh rate of 85Hz.

	Min.	Max.
Refresh Rate	-	85Hz

The information contained herein is the exclusive property of E Ink Holdings Inc., and shall not be distributed, reproduced, or disclosed in whole or in part without prior written permission of E Ink Holdings Inc.

7. Power Sequence

Power rails must be sequenced in the following order :

1. VSS → VDD → VNEG → VPOS (Source driver) → VCOM
2. VSS → VDD → VGL → VGH (Gate driver)

POWER ON

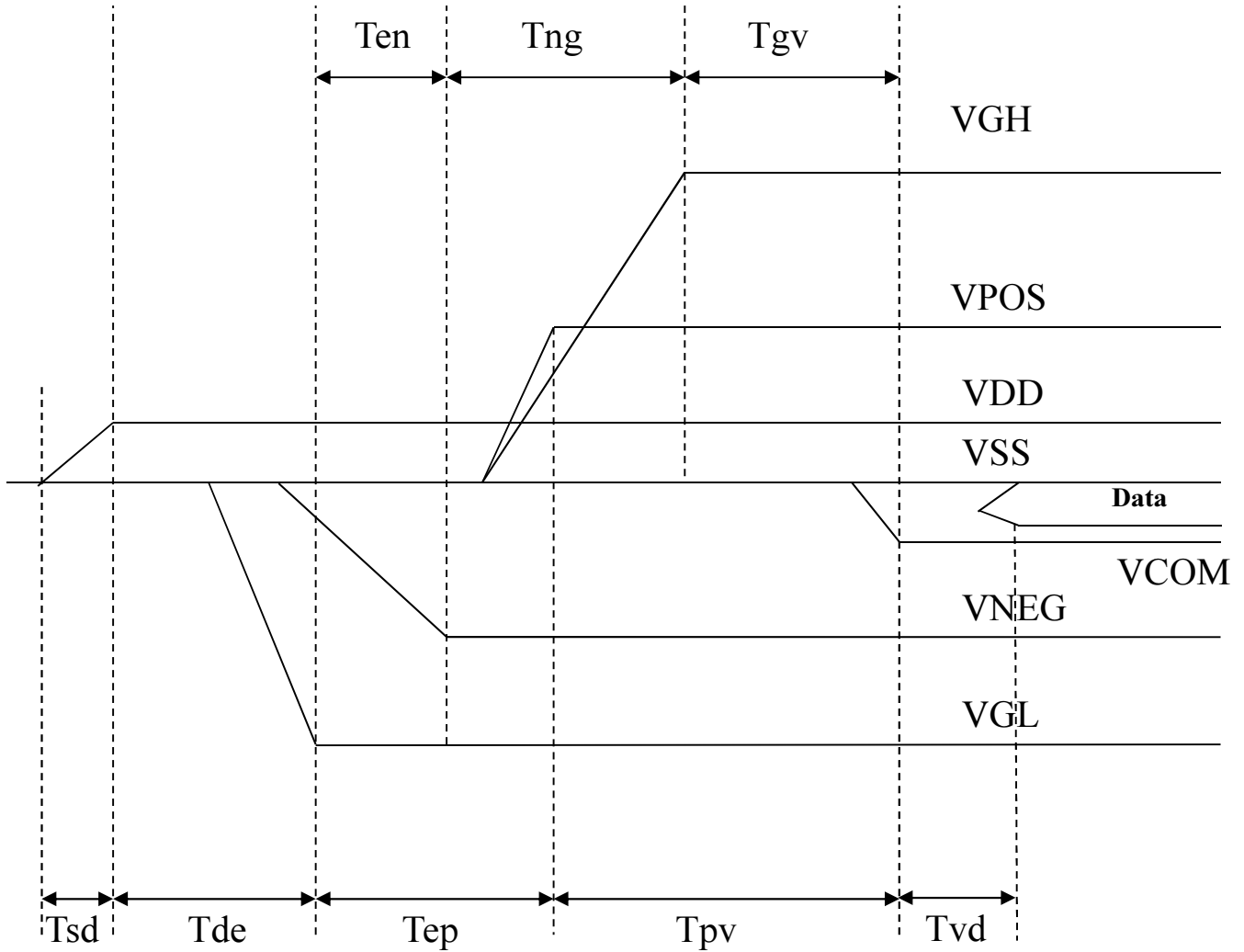

	Min.	Max.
Tsd	30us	-
Tde	100us	-
Tep	1000us	-
Tpv	100us	-
Tvd	100us	-
Ten	0us	-
Tng	1000us	-
Tgv	100us	-

The information contained herein is the exclusive property of E Ink Holdings Inc., and shall not be distributed, reproduced, or disclosed in whole or in part without prior written permission of E Ink Holdings Inc.

POWER OFF

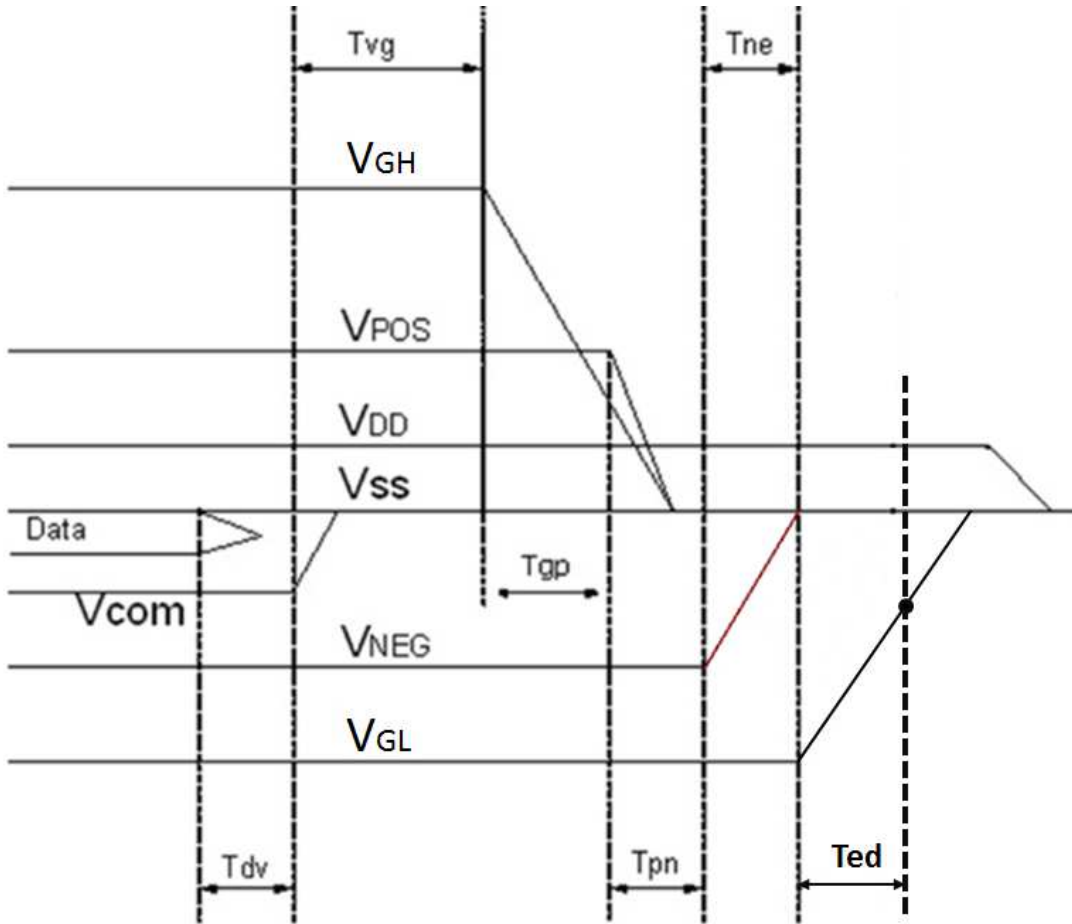

	Min.	Max.	Remark
Tdv	100μs	-	-
Tvg	0μs	-	-
Tgp	0μs	-	-
Tpn	0μs	-	-
Tne	0μs	-	-
Ted	0.5s	-	Discharged point @ -7.4 Volt

Note 7-1: Supply voltages decay through pull-down resistors.

Note 7-2: Begin to turn off V_{GL} power after V_{NEG} and V_{POS} are completely or almost discharged to GND state.

Note 7-3: V_{GL} must remain negative of V_{COM} during decay period.

8. Optical Characteristics

8.1 Specifications

Measurements are made with that the illumination is under an angle of 45 degrees, the detector is perpendicular unless otherwise specified.

T = 25°C

Symbol	Parameter	Conditions	Min.	Typ.	Max.	Unit	Note
R	Reflectance	White	30	40	-	%	Note 8-1
Gn	N th Grey Level	-		$DS+(WS-DS) \times n/(m-1)$		L*	-
CR	Contrast Ratio	-	9	12	-		-

WS: White state , DS: Dark state, Gray state from Dark to White :DS 、 G1 、 G2... 、 Gn... 、 Gm-2 、 WS
m:4 、 8 、 16 when 2 、 3 、 4 bits mode

Note 8-1: Luminance meter: Eye – One Pro Spectrophotometer

8.2 Definition of contrast ratio

The contrast ratio (CR) is the ratio between the reflectance in a full white area (Rl) and the reflectance in a dark area (Rd): $CR = Rl / Rd$

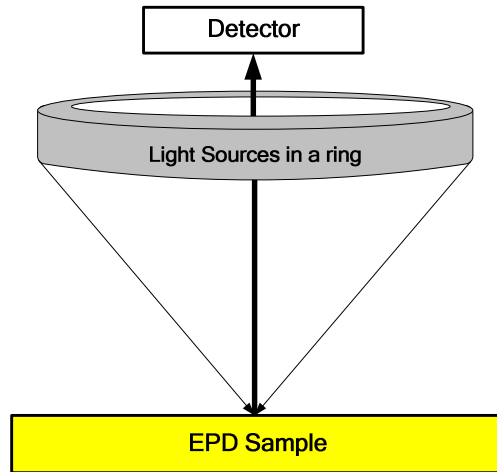

8.3 Reflection Ratio

The reflection ratio is expressed as:

$$R = \text{Reflectance Factor}_{\text{white board}} \times (L_{\text{center}} / L_{\text{white board}})$$

L_{center} is the luminance measured at center in a white area (R=G=B=1). $L_{\text{white board}}$ is the luminance of a standard white board. Both are measured with equivalent illumination source. The viewing angle shall be no more than 2 degrees.

9. Handling, Safety and Environmental Requirements and Remark

Warning
The display glass may break when it is dropped or bumped on a hard surface. Handle with care. Should the display break, do not touch the electrophoretic material. In case of contact with electrophoretic material, wash with water and soap.

Caution
The display module should not be exposed to harmful gases, such as acid and alkali gases, which corrode electronic components.
Disassembling the display module can cause permanent damage and invalidate the warranty agreements.
IPA solvent can only be applied on active area and the back of a glass. For the rest part, it is not allowed.

Mounting Precautions
(1) It's recommended that you consider the mounting structure so that uneven force (ex. Twisted stress) is not applied to the module.
(2) It's recommended that you attach a transparent protective plate to the surface in order to protect the EPD. Transparent protective plate should have sufficient strength in order to resist external force.
(3) You should adopt radiation structure to satisfy the temperature specification.
(4) Acetic acid type and chlorine type materials for the cover case are not desirable because the former generates corrosive gas of attacking the PS at high temperature and the latter causes circuit break by electro-chemical reaction.
(5) Do not touch, push or rub the exposed PS with glass, tweezers or anything harder than HB pencil lead. And please do not rub with dust clothes with chemical treatment. Do not touch the surface of PS for bare hand or greasy cloth. (Some cosmetics deteriorate the PS)
(6) When the surface becomes dusty, please wipe gently with absorbent cotton or other soft materials like chamois soaks with petroleum benzene. Normal-hexane is recommended for cleaning the adhesives used to attach the PS. Do not use acetone, toluene and alcohol because they cause chemical damage to the PS.
(7) Wipe off saliva or water drops as soon as possible. Their long time contact with PS causes deformations and color fading.

Data sheet status	
Product specification	This data sheet contains preliminary product specifications.
Limiting values	
Limiting values given are in accordance with the Absolute Maximum Rating System (IEC 134). Stress above one or more of the limiting values may cause permanent damage to the device. These are stress ratings only and operation of the device at these or at any other conditions above those given in the Characteristics sections of the specification is not implied. Exposure to limiting values for extended periods may affect device reliability.	
Application information	
Where application information is given, it is advisory and does not form part of the specification.	

Remark
All The specifications listed in this document are guaranteed for module only. Post-assembled operation or component(s) may impact module performance or cause unexpected effect or damage and therefore listed specifications is not warranted after any Post-assembled operation.

10. Reliability Test

	Test	Condition	Method
1	High Temperature Operation	T=+50°C RH=30% for 240hrs	IEC 60 068-2-2Bp
2	Low Temperature Operation	T=0°C for 240hrs	IEC 60 068-2-2Ab
3	High Temperature Storage	T=+70°C RH=40% for 120hrs (Test in white pattern)	IEC 60 068-2-2Bp
4	Low Temperature Storage	T=-25°C for 120hrs (Test in white pattern)	IEC 60 068-2-1Ab
5	High Temperature High Humidity Operation	T=+40°C RH=90% for 168hrs	IEC 60 068 2-3CA
6	High Temperature High Humidity Storage	T=+60°C RH=80% for 120hrs (Test in white pattern)	IEC 60 068 2-3CA
7	Temperature Cycle	1 cycle [-25°C 30min] -> [+70°C 30min] : 100cycles (Test in white pattern)	IEC 60 068-2-14
8	Solar radiation test	765W/m2 for 168hrs 40°C (Test in white pattern)	IEC 60 068-2-5Sa
9	Electrostatic Efficient (non-operating)	(Machine model)+/- 250V 0Ω, 200pF	IEC 62179 IEC 62180
10	Package Vibration	1.04G Frequency 10-500Hz Direction: X,Y,Z Duration: 1 hours in each direction	Full package for shipment
11	Package Drop Impact	Drop from height of 122 cm on concrete surface Drop sequence: 1corner, 3edges, 6surfaces One drop for each	Full package for shipment
12	Stylus Tapping	POLYACETAL Pen Top R: 0.8mm Load: 300gf Speed: 2times/sec Total: 13,500times	Test with bezel and device to simulate full product test.

[Criteria]

In the standard conditions, there is not display function NG issue occurred. (Including: line defect ,no image). All the cosmetic specification is judged before the reliability stress.

11. Border Definition

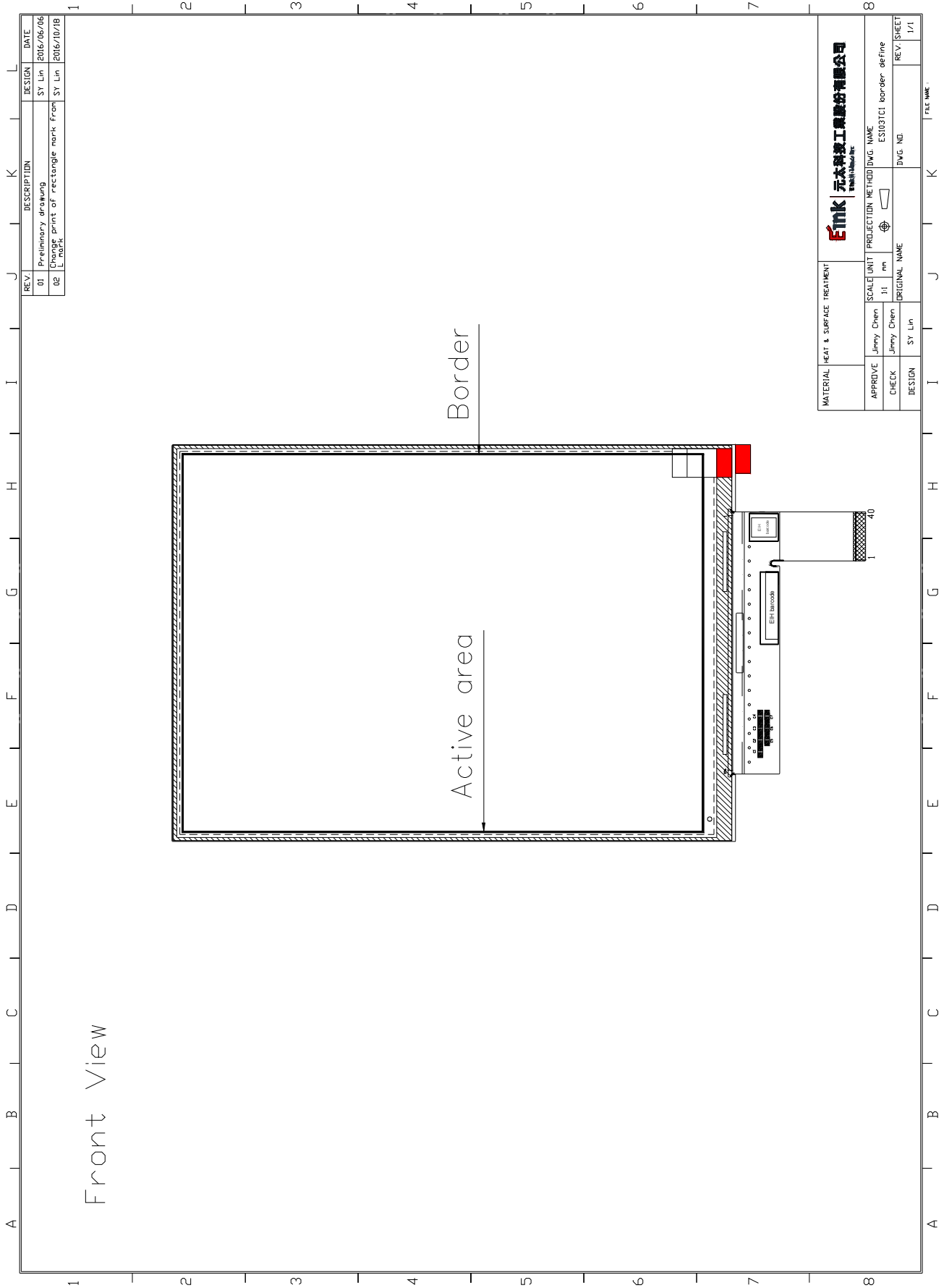

12. Block Diagram

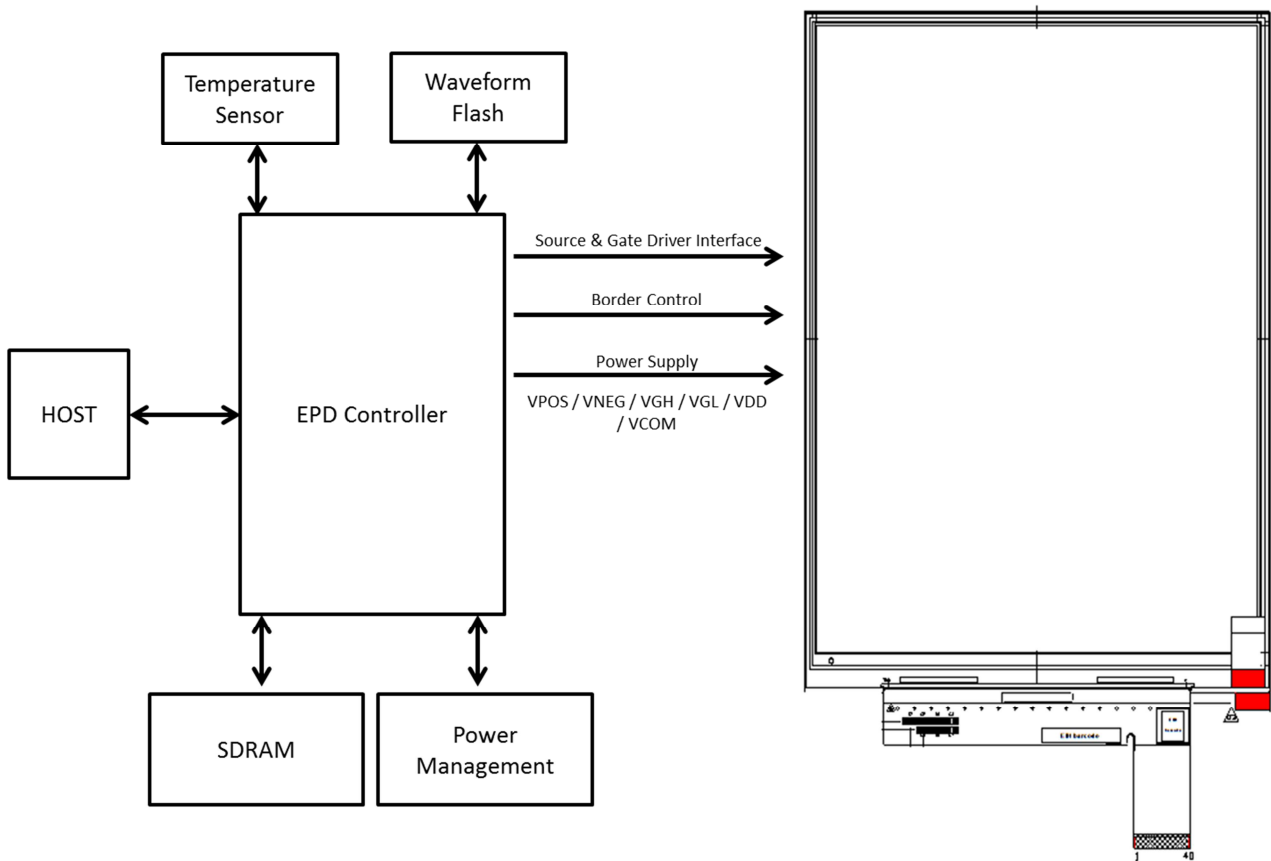

13. Packing

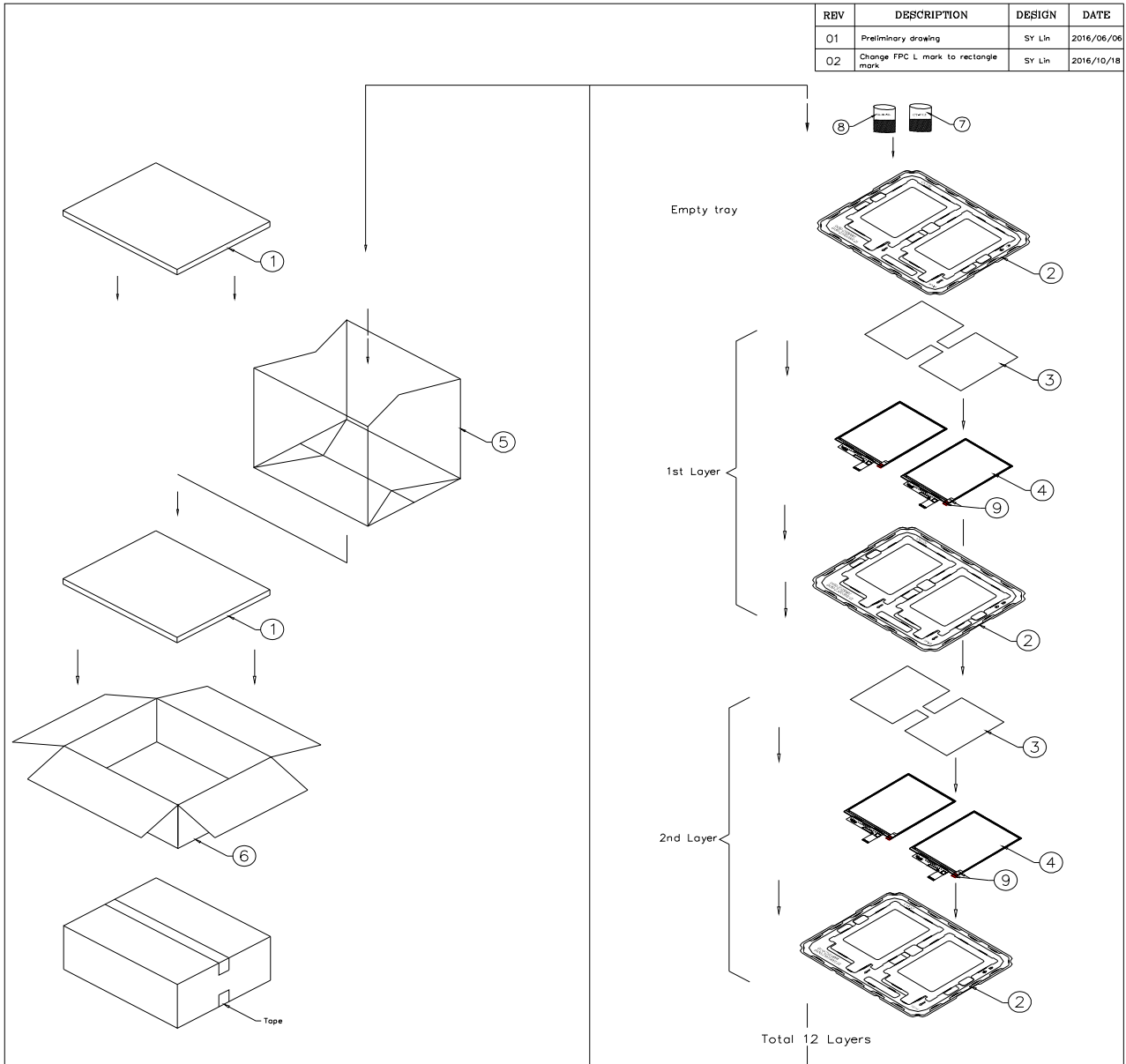

REV	DESCRIPTION	DESIGN	DATE
01	Preliminary drawing	SY Lin	2016/06/06
02	Change FPC L mark to rectangle mark	SY Lin	2016/10/18

NOTE:

1. One layer include: 1 piece of cushion sheet, 2 pcs module & 1 piece of tray.
2. Q'TY: 24 pcs panel/carton.
3. Dimension: 445*365*170mm
4. Weight: 4KG
5. Make sure tray stacked with 0° rotation. We can check this by lateral side view.

9	Peeling tape	48	
8	30g 加厚硬合金紙(厚度0.3mm)73*95mm	2	
7	防錫劑(保護容積25L)	3	
6	CARTON INTERNAL	1	
5	摺口袋450*380*580mm	1	抗靜電
4	ES103TC1	24	
3	EPE CUSHION SHEET	12	抗靜電
2	TRAY	13	抗靜電
1	EPE FOAM	2	
ITEM	DESCRIPTION	QTY	REMARK

MTL.SPEC.		UNSPECIFIED TOL'S ±5.0mm		REMARK		元太科技工業股份有限公司 E Ink Holdings Inc.	
		ANGLE					
		ROUGHNESS					
APPROVE	Jimmy Chen	2016/6/6	SCALE	UNIT	SHEET	DWG.TITLE	
CHECK	Jimmy Chen	2016/6/6	1:1	mm	1 OF 1	ES103TC1 PACKING	
DESIGN	SY Lin	2016/6/6	MTL.NO.		DWG.NO.		REV. A
							SIZE 4