

Enabling the **Internet of Things** (IoT)

EUF-IND-T0970

Cyril Zarader | BD Microcontrollers EMEA

J A N . 2 0 1 5



External Use

Freescale, the Freescale logo, AllWin, C-5, CodeTEST, CodeWarrior, ColdFire, ColdFire+, C-Ware, the Energy Efficient Solutions logo, Kinetic, MajeV, mobileGT, PED, PowerQUICC, Processor Expert, QorIQ, QorIQ Qonvergence, Qorvix, Ready File, SafeSecure, the SafeSecure logo, StarCore, Symphony, iM7G6, Vybrid and Xilinx are trademarks of Freescale Semiconductor, Inc., Reg. U.S. Pat. & Tm. Off. All other trademarks, service marks, and logos are the property of their respective owners. © 2015 Freescale Semiconductor, Inc.



Agenda



Freescale Connected Intelligence helps to bring the full potential of the **IoT** to life, delivering intelligence everywhere so designs and whole systems **can scale and interact seamlessly and securely**

- **Understanding IoT to understand IoT challenges**
- **Solutions for Wireless Connectivity**



A woman with long dark hair, wearing a dark sleeveless top, is smiling and looking towards the camera. She is standing next to an ATM. The ATM is white and has a screen and keypad. There are several concentric white circles overlaid on the image, representing wireless signal waves. The background is a blurred outdoor setting with a wooden wall on the left.

Some will think
this represents a
typical edge node

or this...



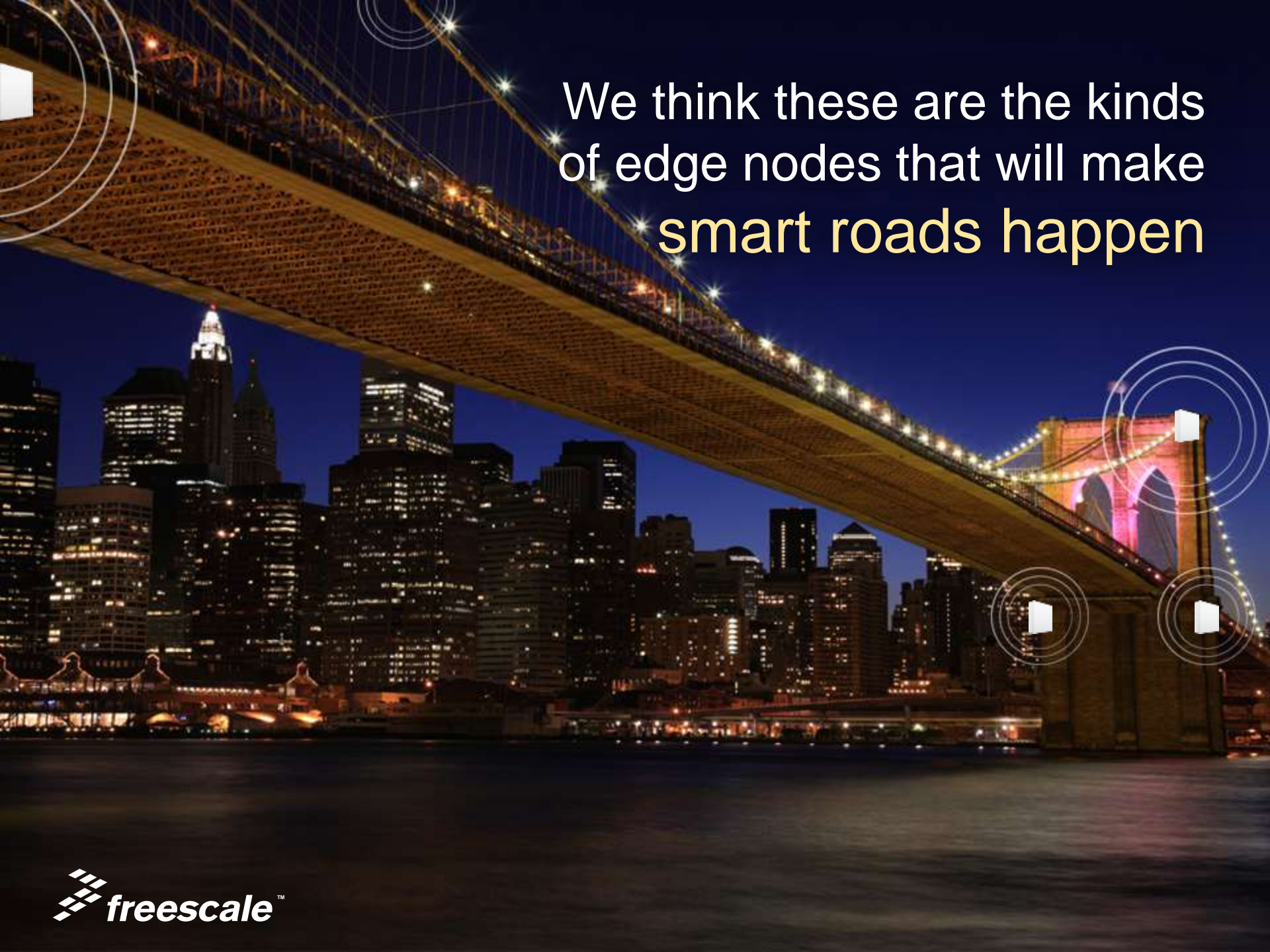

We think these are the kinds
of edge nodes that will make
smart roads happen

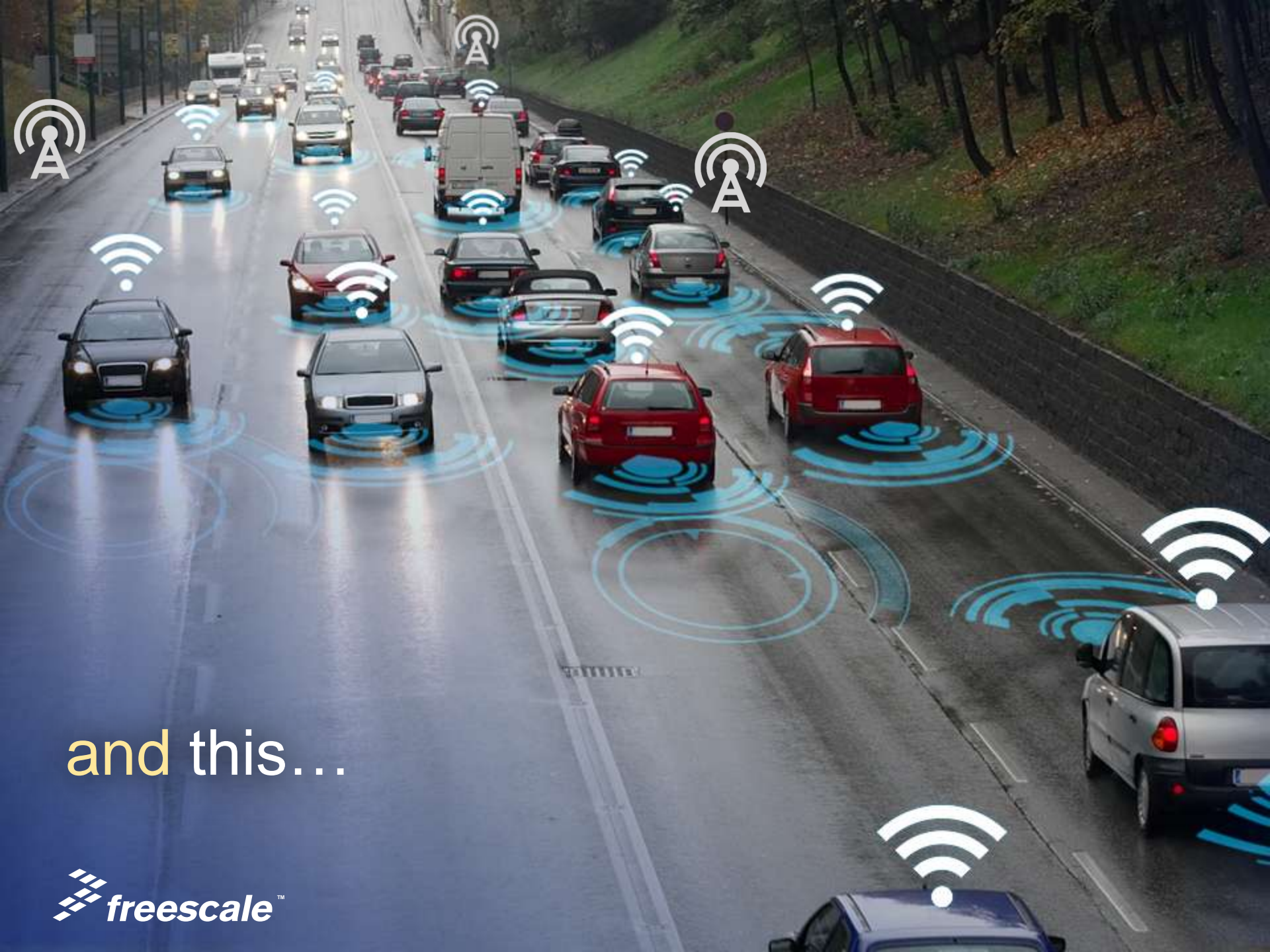

and this...

...smart agriculture

Automate Irrigation

Detect Climate

1 2 3 4 5

1:00 p.m.

Sending... "Watering schedule change"

Receiving... "Current water levels"

...smart farming

Location
Nutrition
Health
Stress



...smart home



▶ Home Energy Activated

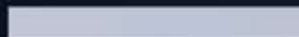

▶ Home Cooling System Schedule



Sending...

"Delay AC activation"



Receiving...

"Returning 30 minutes late"



...smart wearables



INTERNET of Things

Sense

Process

Communicate





The Challenges

Challenge of Co-existence



Smart Building



Smart Traffic



Smart Lighting



Smart Grid



Smart Health



Smart Industry

Challenge of Interoperability



Smart Home

Focus on home automation, but includes energy management



Smart Car

Charging electric vehicles (EV) can be done in the home garage, making the car a part of the grid

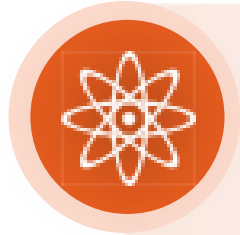

Smart Energy

Focus on reducing energy consumption at a variety of facilities, including at home

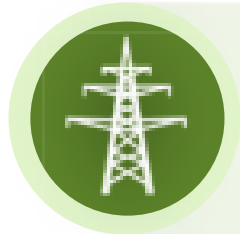

Smart Grid

Focus on optimizing grid utilization

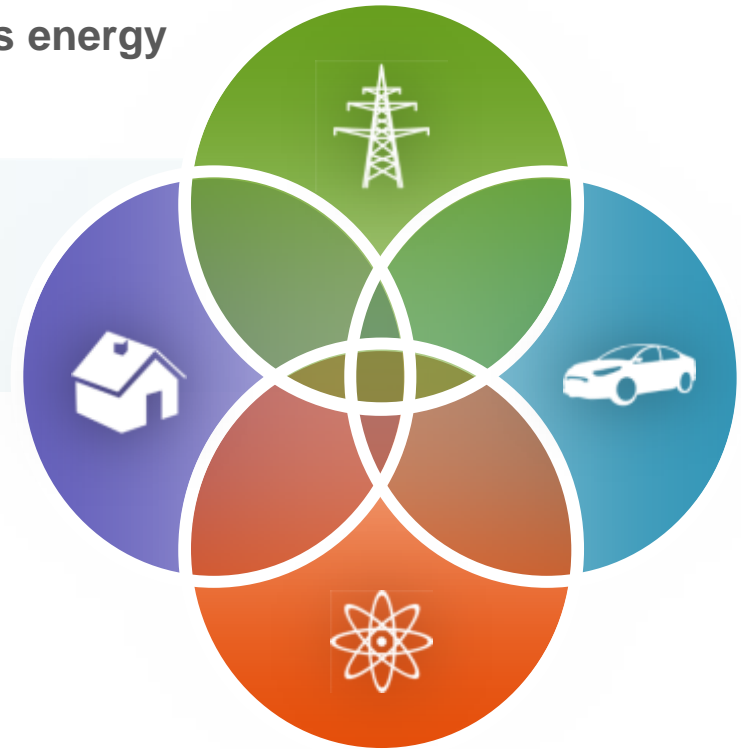

Challenge of Languages

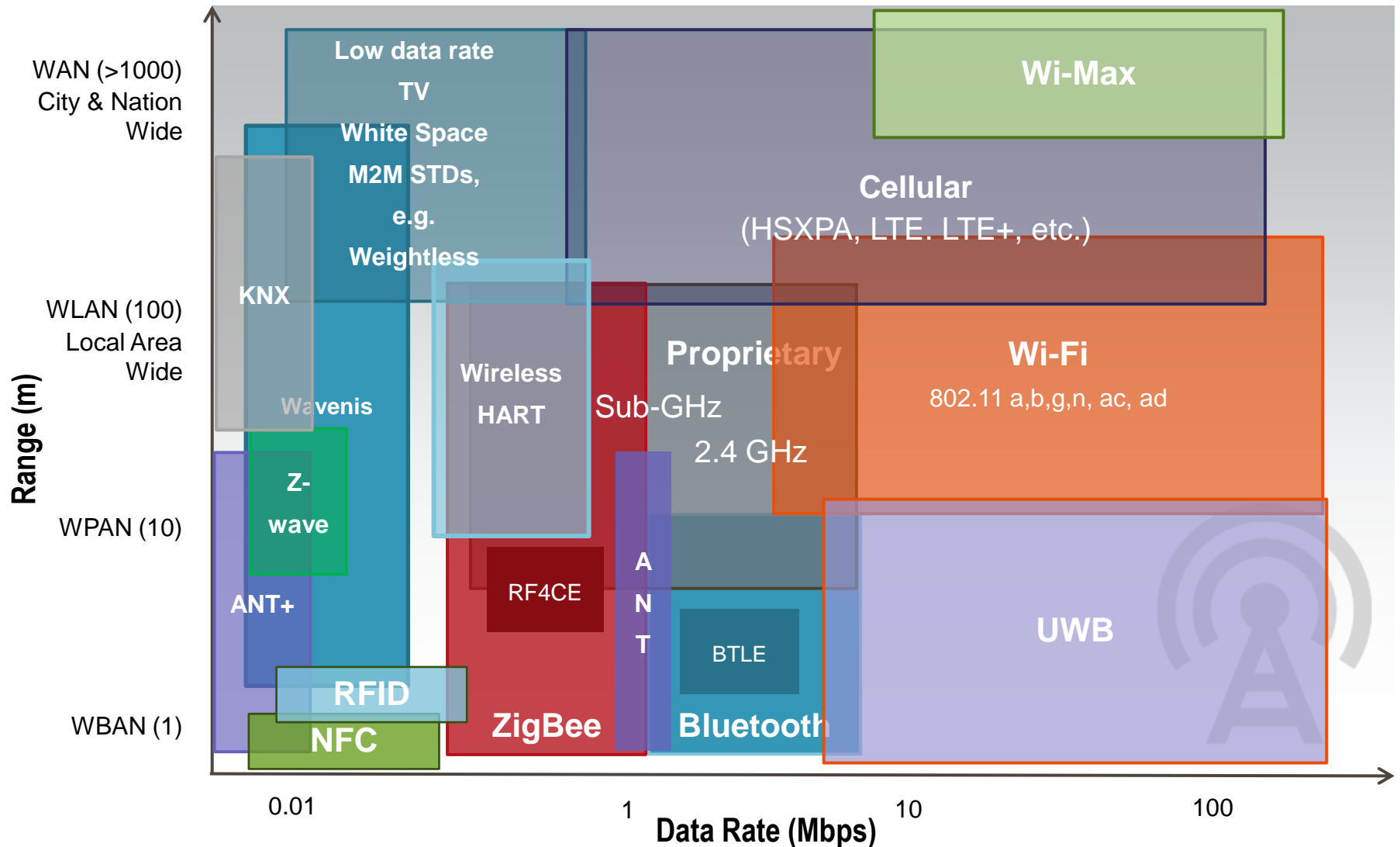

Challenge of Users Threat



The Internet is a Surveillance State

By Bruce Schneier, Special to CNN

March 16, 2013

The Internet is a surveillance state. Whether we admit it to ourselves or not, and whether we like it or not, we're being tracked all the time. One reporter used a tool called Collusion to track who was tracking him; **105 companies tracked his Internet use** during one 36-hour period.

Challenges of Technology Trends

Legacy Systems

- **Closed Networks**
No connection to outside world
- **Proprietary Networks**
Fieldbus protocols
- **Hardware Control**
Physical hardware difficult to tamper
- **Local Access**
Operator beside the machine
- **Limited Tampering**
Fewer attempts to interfere with critical infrastructure

Present Systems

- **Open Networks** Connected to global communications network for remote access
- **Standard Networks**
Industrial Ethernet protocols
- **Software Control**
Easier to tamper with less obvious impact
- **Remote Access**
Operator connects via wired or wireless from distant location
- **Increased Tampering**
More frequent attempts to interfere with critical infrastructure, e.g. electric utilities, water treatment and transportation systems



The Challenges

Addressing the diversity of applications

Interoperating services and functions

Securing data and communications



The Solutions for Connectivity

The Languages We Speak

ZigBee®



ZigBee®
Control your world

- RF4CE
- ZigBee PRO
- ZigBee IP

IP Stack

IPv4/IPv6



IP



THREAD

BLE Stack

Core Stack 4.1



Bluetooth®
SMART

MAC/PHY



IEEE
802.15.4

- Sub-GHz
- 2.4 GHz

BLE LL/PHY



- 2.4 GHz
- Bluetooth 4.1

Wireless Connectivity Solutions

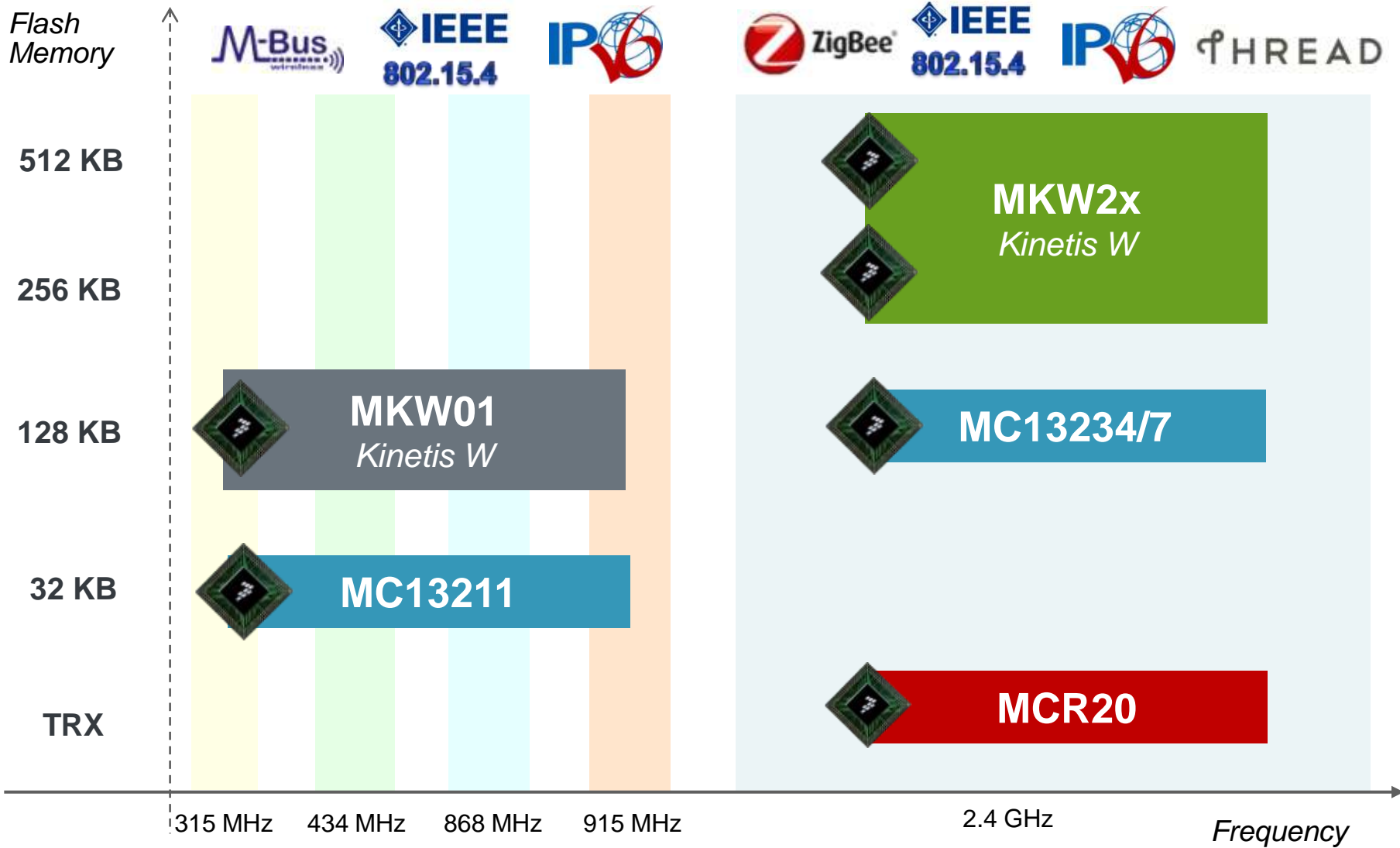

Wireless Connectivity Solutions

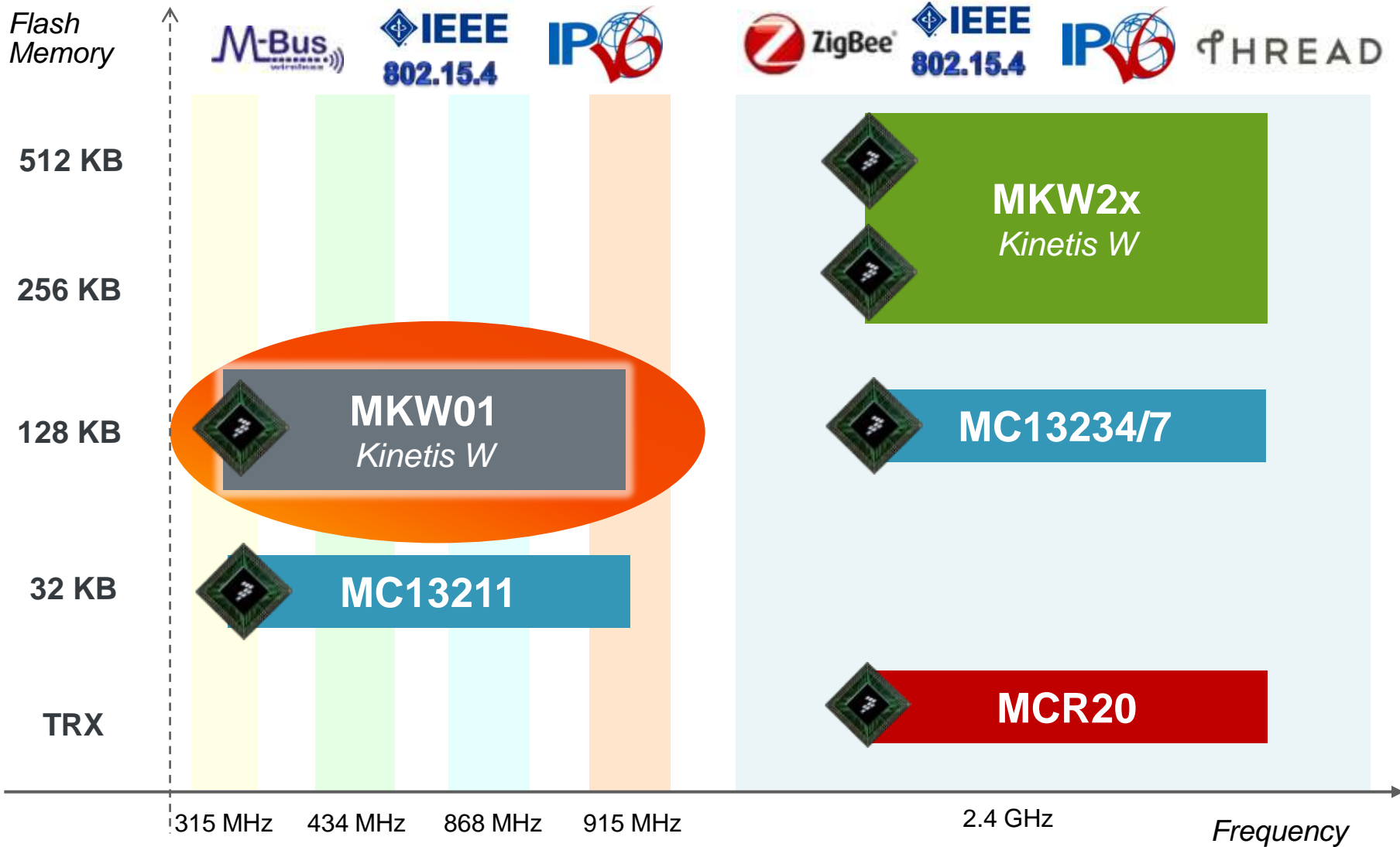

Kinetis KW01 Wireless MCU (Sub 1-GHz)

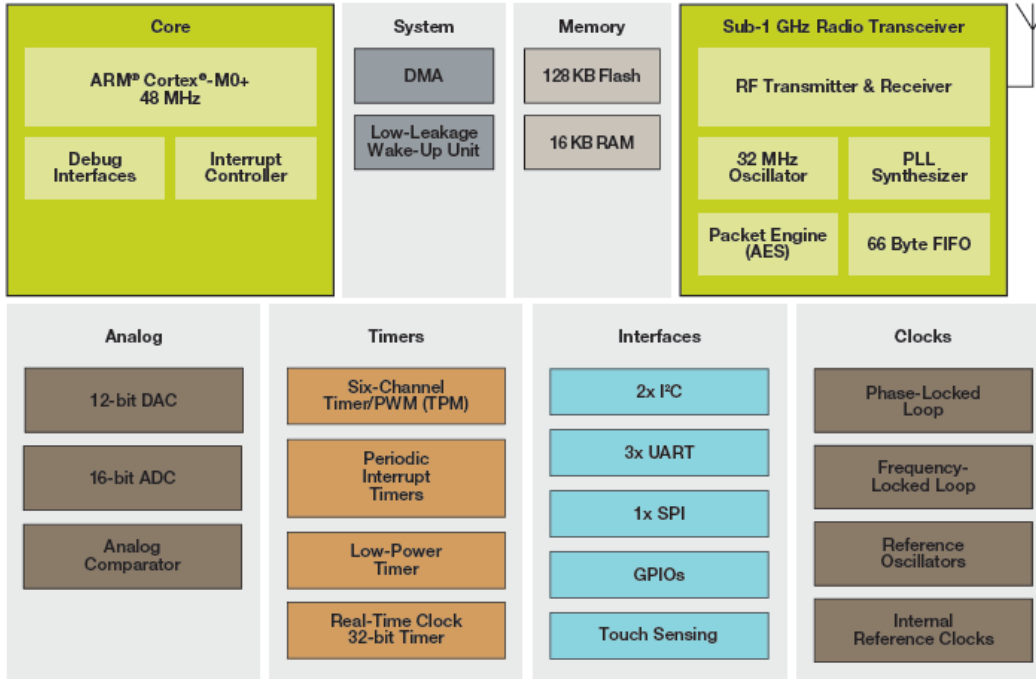

CPU

- 32-bit ARM® Cortex® M0+ 48 MHz Core
- 128 KB flash and 16 KB SRAM

Radio Transceiver, Sub 1-GHz

- Supports 290-340 MHz, 424-510 MHz, and 862-1020 MHz frequency bands
- FSK, GFSK, MSK, GMSK and OOK modulations up to 600 kbps
- Up to -120 dBm RX sensitivity @ 1.2 kbps
- -18 to +17 dBm TX output power in steps of 1 dBm

Ultra Low Power for Battery Operated Devices

- Typical consumption
 - 1.7 μ A standby
 - <130 μ A/MHz CPU system run mode
 - 16 mA RX peak
 - 20 mA TX peak at 0 dBm, 33 mA at +10 dBm

Software

- SMAC (Simple-MAC), user modifiable for proprietary protocols

System

- 16-bit ADC, Capacitive Touch Sensing, I²C, UART, SPI, Timers
- Operating Range: 1.8V to 3.6V, -40C to +85C

Orderable Part

Part Number	Description
MKW01Z128CHN	<ul style="list-style-type: none"> • 290–1020 MHz smart radio • 128 KB flash/16 KB RAM • 60 MAPLGA 8 mm x 8 mm • Bulk tray



MKW01Z128CHN Application Schematic

- Minimum requirements (RF+MCU) :
 - A 32 MHz crystal for RF operation
 - A matching network to filter harmonics and match antenna (pcb, power and load dependant...)

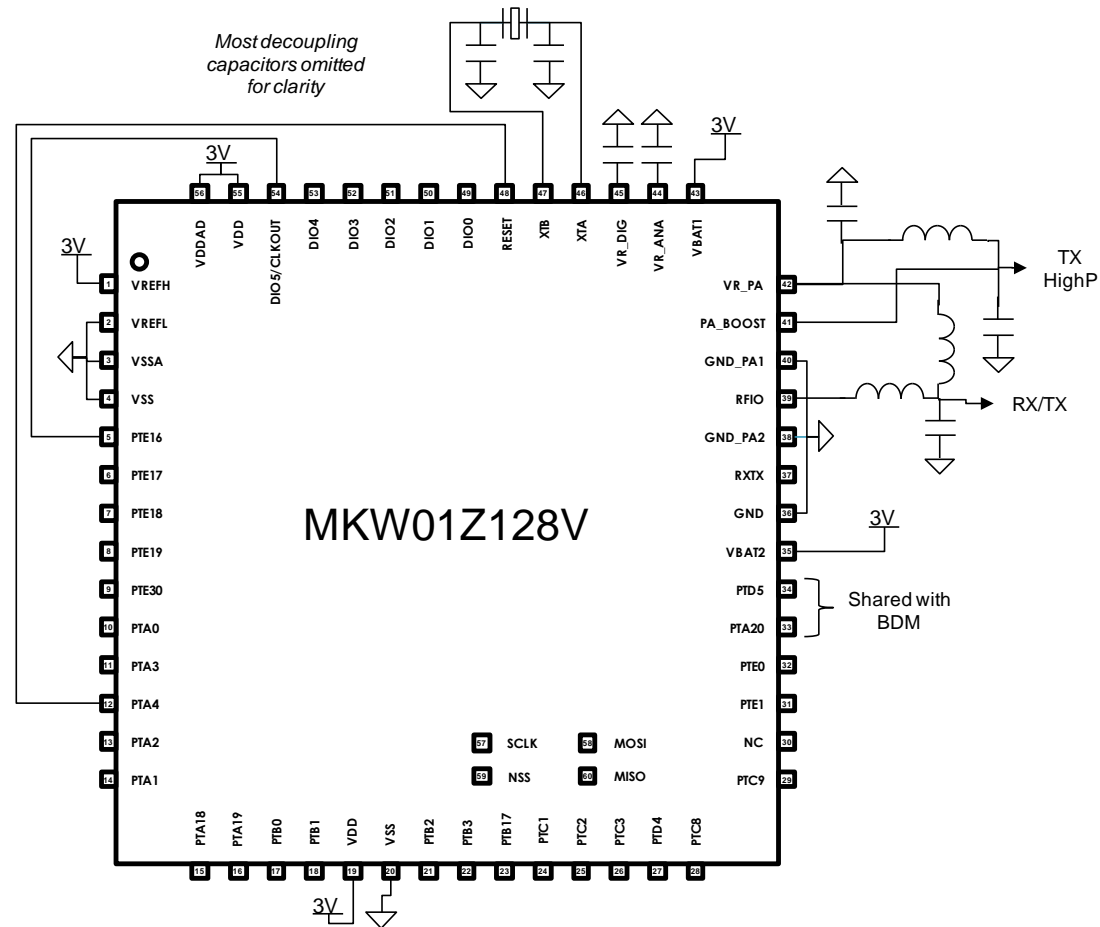

MKW01x Development Kits

- **Modular Reference Board (MRB).**

- **Features**

- Flash reprogramming and in-circuit hardware debugging, test points & jumpers.
 - USB port on the MRB to interface with PC
 - Reference design for RF matching networks on board.
 - SMA connectors for RFIO or separate TX/RX.
 - Out-of-box application with Radio Utility GUI and firmware.
 - Quick Start Guide
 - Can be mounted on TWR-RF which can in turn be installed in a TOWER system.



MKW01 – Radio Configuration and Test Tool

- Allow fast evaluation of the radio performance in a lab environment without need for writing software
 - Analysis of TX spectrum (output power, harmonics, ..)
 - Modulation scheme impact (GFSK, BT, Mod index) on spectrum
 - Help on matching network tuning
 - Analysis of RX Sensitivity performance (RSSI, LNA input impedance, OOK threshold, AFC)
- Run on PC connected through USB to Module Radio Board.
- Free of charge, free download from Freescale website

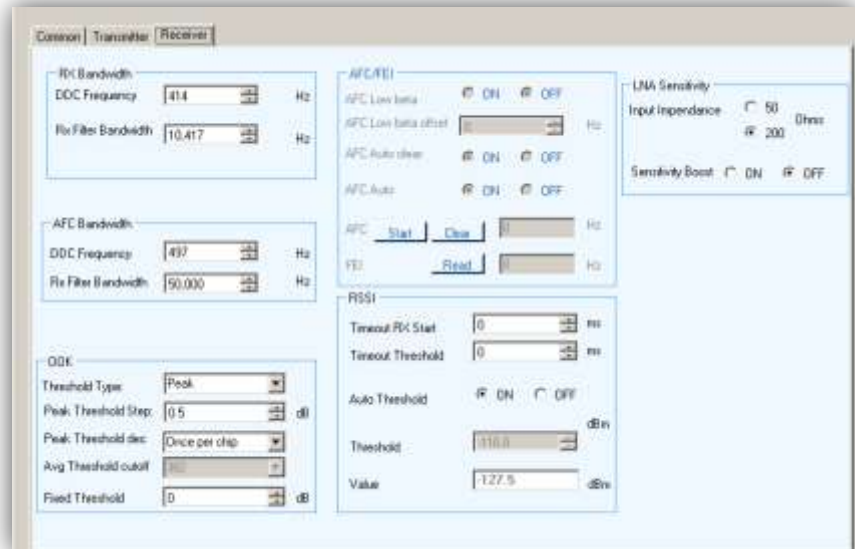

Sub-GHz Wireless Communication Protocols

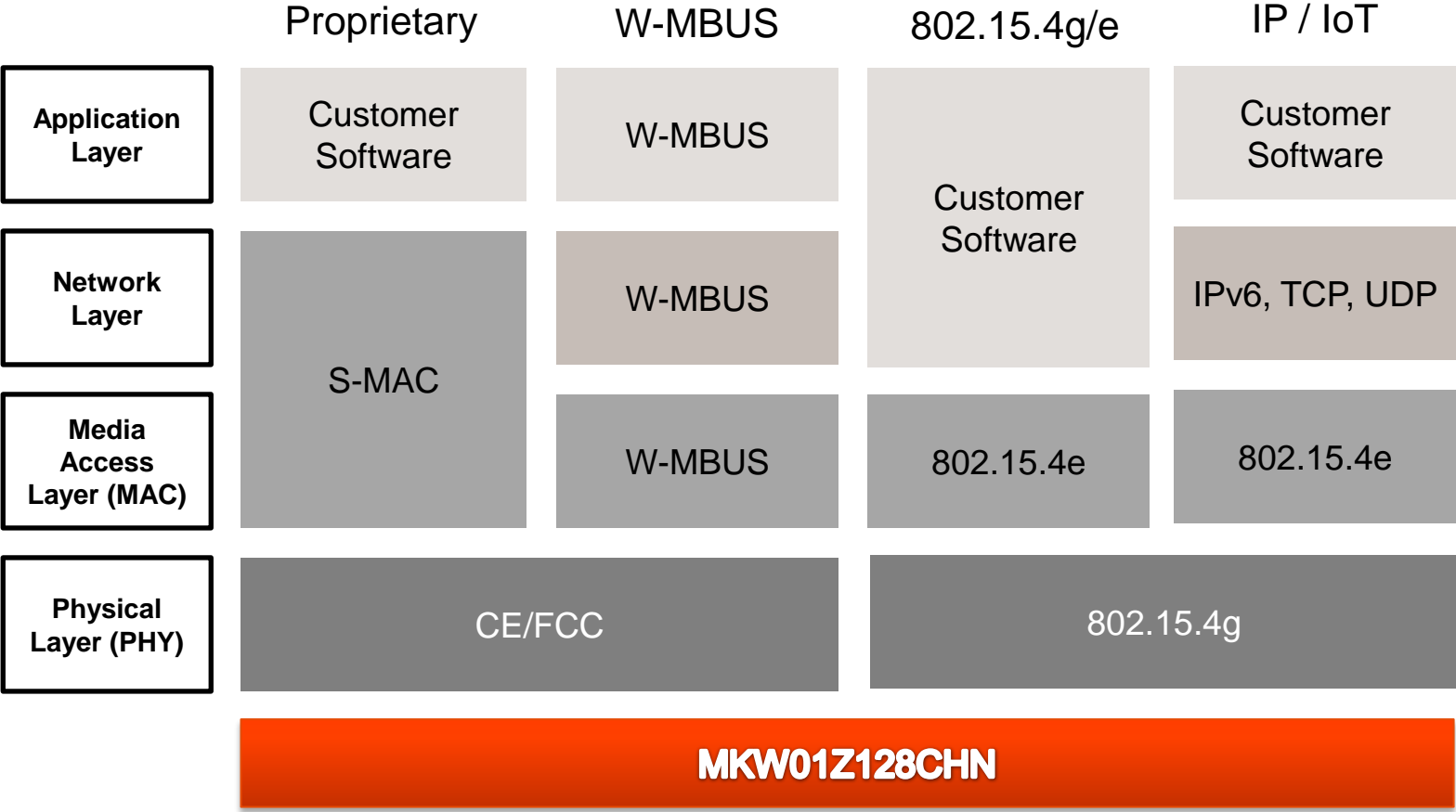

Wireless Connectivity Solutions

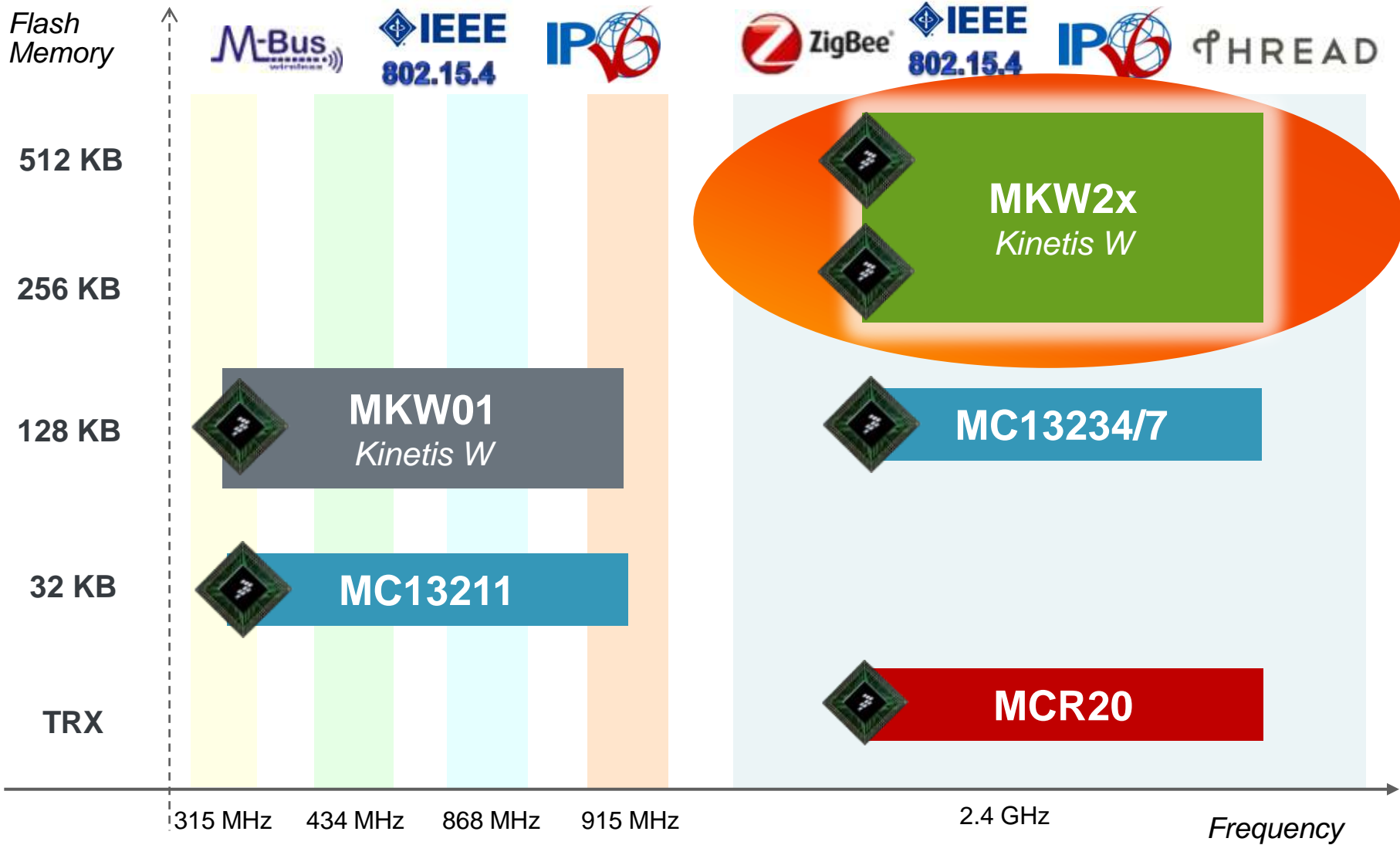

Kinetis KW2x Wireless MCU (2.4 Hz)

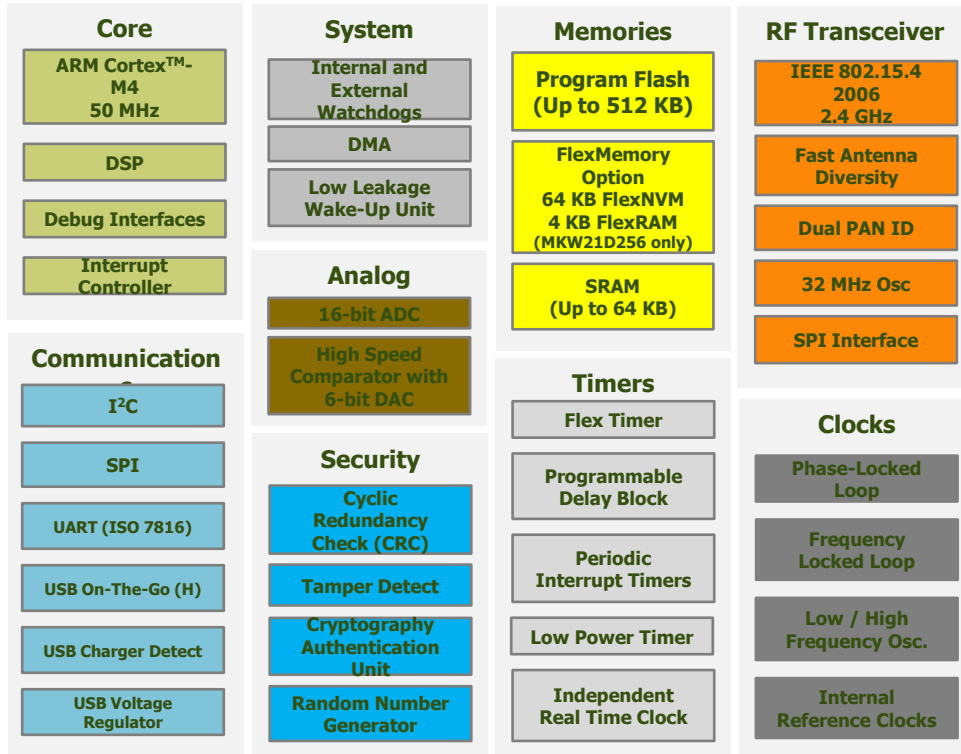

Device	Flash	RAM	Feature	Package
MKW21D256VHA5	256 KB	32 KB	No USB	8x8 63-pin LGA
MKW21D512VHA5	512 KB	64 KB	No USB	8x8 63-pin LGA
MKW22D512VHA5	512 KB	64 KB	USB	8x8 63-pin LGA
MKW24D512VHA5	512 KB	64 KB	USB and Smart Energy 2.0	8x8 63-pin LGA

CPU

- 50 MHz Cortex M4 CPU core
- Up to 512 KB flash & up to 64 KB SRAM
- Optional (MKW21D256): 64 KB FlexNVM & 4 KB FlexRAM
- Typical current: 250 uA/MHz run, 1.7uA RTC standby

Radio Transceiver, 2.4 GHz

- IEEE-802.15.4 compliant
- -102 dBm RX sensitivity and +8 dBm TX output power
- Peak typical current: 17mA TX and 19mA RX

Security

- Active and passive tamper detection with RTC timestamp
- Crypto engine: DES, 3DES, AES 128-256, SHA-1, SHA-256, MD5, RNG

System

- UART, SPI, I2C, optional USB 2.0 FS/LS H/D/OTG
- 16-bit ADC
- Operating range: 1.8 V to 3.6 V, -40C to +105C



KW2x Unique Features

- **Dual PAN Support**
 - Ability to participate in two networks simultaneously
 - Maintains two sets of network parameters
 - Hardware block : No extra software bandwidth required
- **Antenna Diversity**
 - Maximize the communication link quality
 - No loss from orthogonal antennas
 - Ideal if no freedom in device orientation
 - Hardware block : No extra software bandwidth required
- **Security Block**
 - Tampering detection
 - Cryptographic Encryption Unit

Dual Pan Mode

- In this mode, TRX is able to participate to 2 different PAN (Personal Area Networks)
- 2 sets of parameters are maintained for each PAN:
 - ChannelX
 - MacPanIDX
 - MacShortAddressX
 - MacLongAddrsX
 - PANCORDNTRX
- The transition from one PAN to the other can be manual (under software control) or automatic
- Automatic transition is done using a programmable timer with a PAN Dwell Time from 0.5ms to 3.2s
- If both PAN are defined on the same channel, TRX is able to process both PAN simultaneously (no PAN Dwell Time to define)

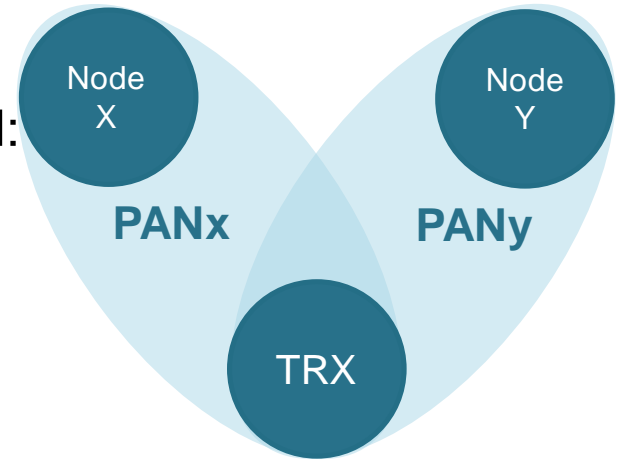

RF4CE & Home Automation Dual PAN



KW2x Unique Features

- **Dual PAN Support**
 - Ability to participate in two networks simultaneously
 - Maintains two sets of network parameters
 - Hardware block : No extra software bandwidth required
- **Antenna Diversity**
 - Maximize the communication link quality
 - No loss from orthogonal antennas
 - Ideal if no freedom in device orientation
 - Hardware block : No extra software bandwidth required
- **Security Block**
 - Active and passive tamper detection with RTC timestamp
 - Cryptographic Encryption engine: DES, 3DES, AES 128-256, SHA-1, SHA-256, MD5, RNG

KW2x Development Kit



Freescale Tower System Form Factor

- Use standalone or in Tower System
- Boards sold individually
- Combine as many boards as needed

Part Numbers:

TWR-KW21D256	\$149
TWR-KW24D512	\$149



• An external antenna needs to be purchased separately

Kit Features

- Can use PCB “F” antenna or bypass for external antenna via RF connector
- Open-SDA debugging
- USB port to interface with PC
- Configurable I/O access
- LEDs and switches for demonstration, monitoring and control
- Full software stacks and applications
- BeeStack (ZigBee Pro, RF4CE, part of BeeKit)
- Flexible IPv6 Stack (6LoWPAN toolbox)
- Quick Start Guide

USB-dongle Form Factor

- Use is as sniffer hardware
- Host processors



USB-KW24D512



BeeKit : New Approach to Wireless Applications Development

- Graphical user interface (GUI) to create, and validate network configuration
 - Complementary tool to traditional IDEs
- Codebases deliver libraries, templates and applications
 - Supports Simple MAC (SMAC), IEEE® 802.15.4 MAC, SynkroRF, ZigBee RF4CE, ZigBee and ZigBee Pro
- Exports directly to IDE for development and debug
 - Applications are decoupled from the stack implementation
 - Allows for easy code updates and promotes code reuse

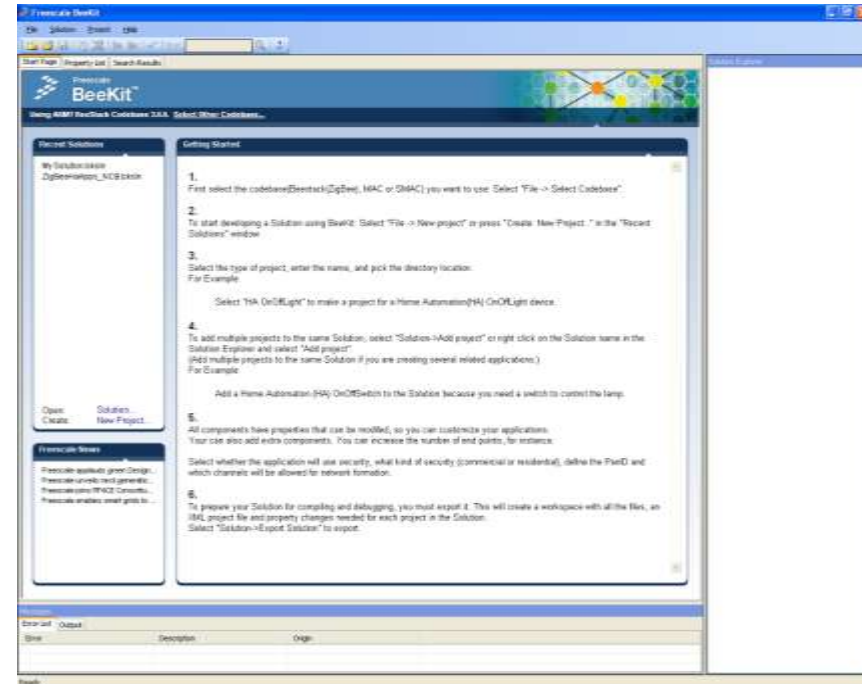

Wireless Connectivity Solutions

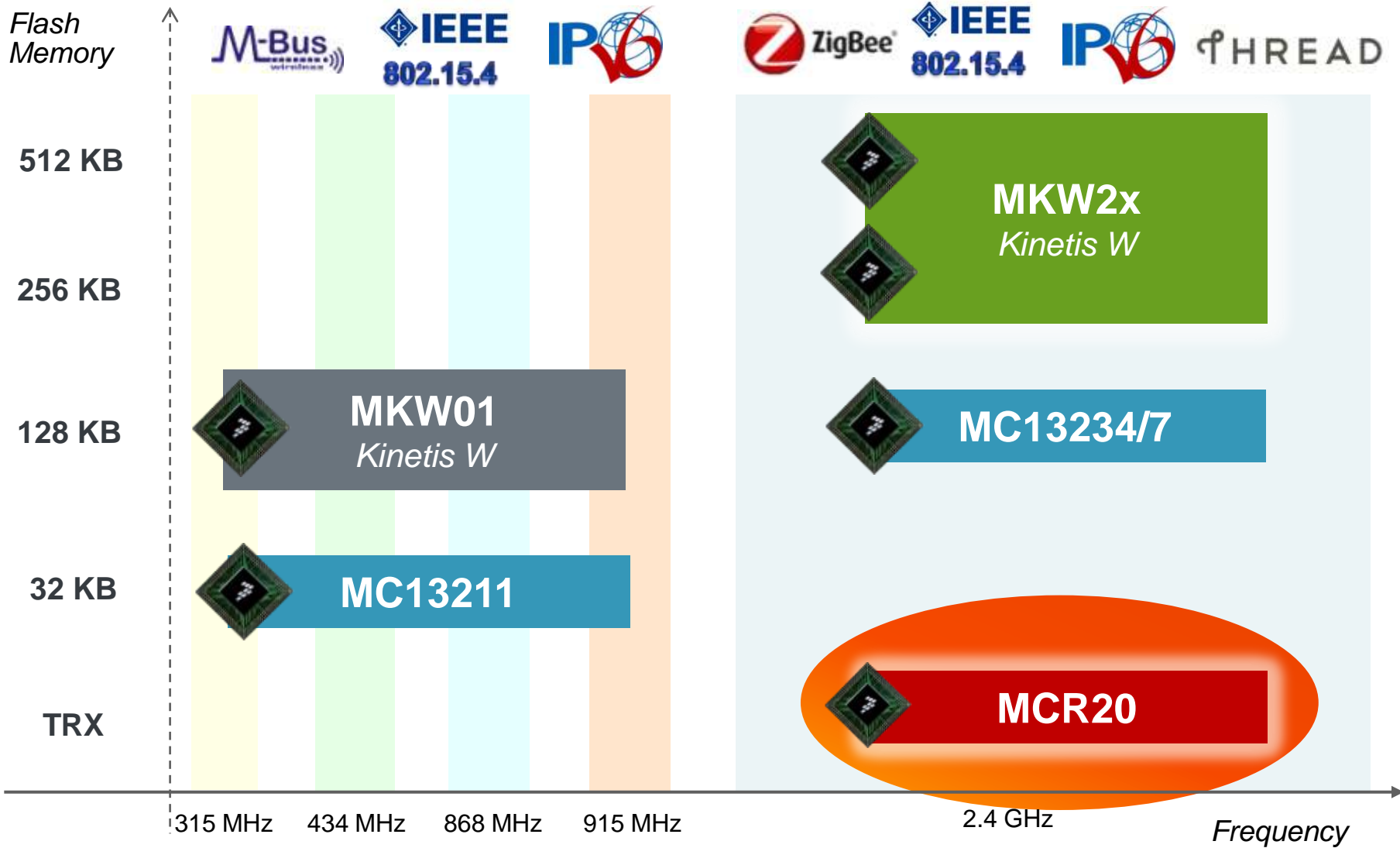

MCR20 High Performance 802.15.4/ZigBee Transceiver

RF Features

- High performance 2.4 GHz IEEE 802.15.4 RF transceiver
- Support for MBAN frequencies (2.36-2.4 GHz)
- Packet processor for hardware acceleration
- Supports single ended and diversity antenna options
- Dual-PAN support
- -30 to + 8 dBm power output
- Support for external PA/LNA (FEM)
- -102 dBm sensitivity
- Tx 18 mA @ 0dBm
- Rx 15 mA LPPS mode, 19.5 mA full Rx
- AES Hardware encryption/decryption
- True Random Number Generator
- SPI Interface (memory mapped)
- 6 GPIO

System Features

- -40°C to 105°C
- 1.8 to 3.6 V
- 5x5 32-pin LGA
- Samples Now, Q2'2015

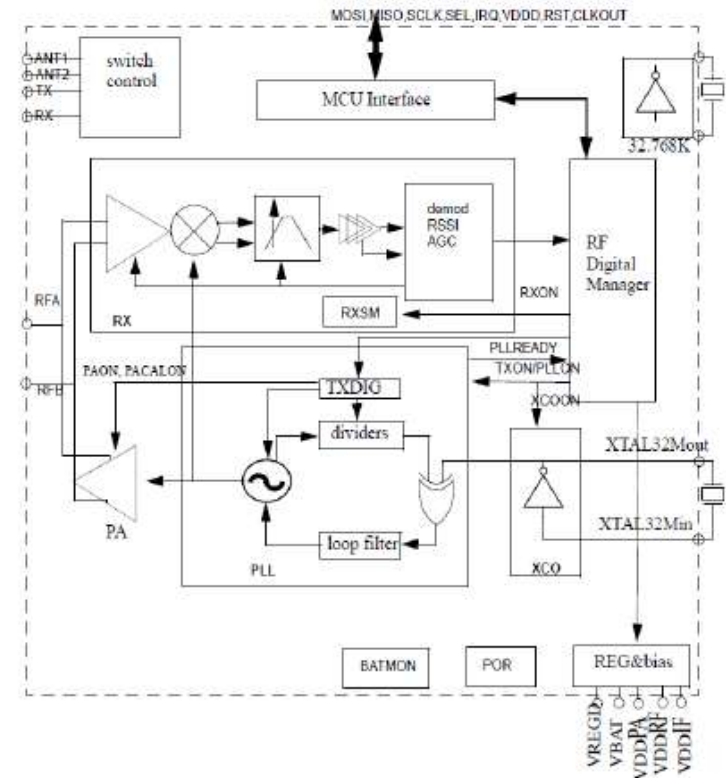

Flexible IP Stack

Wireless IPv6 Stack

For MKW01 and MKW2x

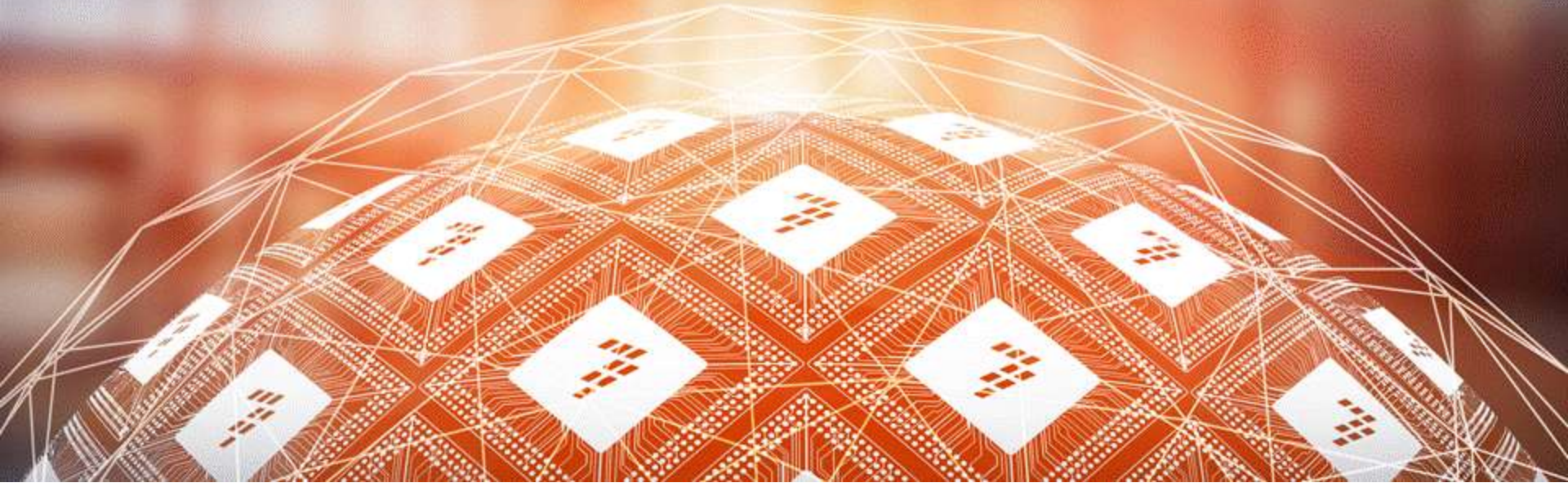

Flexible IP Stack Overview

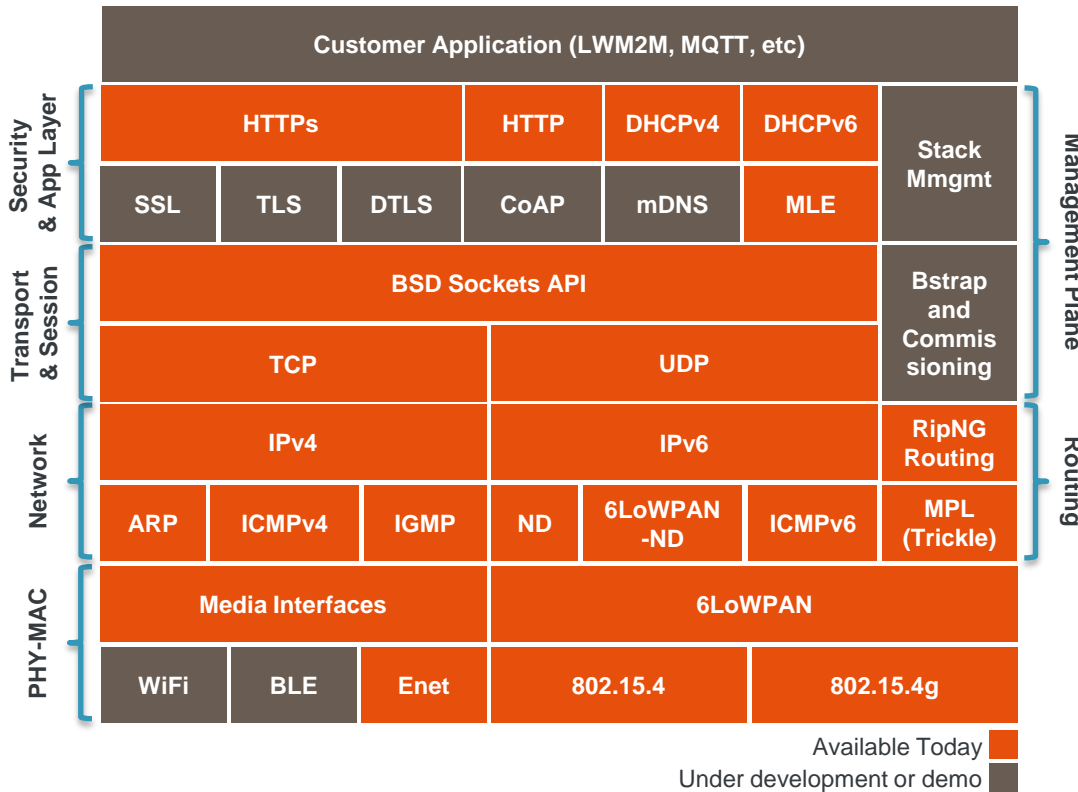

Enables the development of real mesh networks for the connected applications of the future



Lightweight configurable and scalable IPv6 solution which is compliant with IPv6 Logo testing



Easy installation and user friendly out of the box experience



Used as starting point for the Freescale Thread

Product Features:

- **Flexible, configurable and scalable** Dual Stack IPv4 & IPv6 for constrained resources devices
- **Designed for Low Power**, Quick Wake-up Time and Low Memory footprint
- **Multiple interfaces support: 802.15.4 & 802.15.4g with 6LoWPAN**, Ethernet, WiFi and BLE
- **Multiple OS support via Kinetis SDK OSA** and currently running on MQX Lite
- **6LoWPAN and IPv6 stack successfully proven** interoperability with other vendors in various alliances like ZigBeelP, PLC G3 and other.

Supported Features

- **PHY-MAC**
 - IEEE 802.15.4 and 802.15.4g with AES128 MAC security
 - Ethernet and Virtual Ethernet
- **6LoWPAN**
 - RFC4944 – Frame formats, Fragmentation, Mesh and Broadcast Headers (optional)
 - RFC6282 – Stateless and StatefullHeader Compression
- **Network**
 - IPv6 (RFC2460, RFC3484, RFC4291, RFC4862, RFC1981)
 - ICMPv6 (RFC4443), ND (RFC4861) and 6LoWPAN-ND (RFC6775)
 - IPv4 (RFC791, RFC919, RFC922 and RFC950)
 - ARP (RFC826), IGMP (RFC3376) and ICMPv4 (RFC792)
- **Routing**
 - RipNG (RFC2080) → Route Over Ip protocol
 - MPL (RFC6206 and draft IETF Trickle-Multicast)
- **Transport**
 - UDP (RFC768) and TCP (RFC793)
 - BSD Sockets API
- **Application & Management**
 - MLE (IETF draft Kelsey)
 - HTTP (RFC2068)
 - DHCPv4 (RFC2131, RFC2132)
 - DHCPv6 (RFC3315, RFC3633, RFC3646, RFC3736)

Flash and RAM memory Requirements:

Component	Flash [bytes]	RAM [bytes]
Virtual ENET	1741	692
6LoWPAN	10820	936
IPv4	3564	42
IPv6	18643	1498
UDP	1388	46
TCP	5413	74
BSD Sockets	3145	1260
DHCPv4	3042	320
DHCPv6	6729	32
RipNG (Routing)	2425	36
MLE (Mesh Link Establishment)	1906	0
MPL (Trickle – Multicast)	2260	213
Stack Manager	2504	156
Total Flexible IP	63580	5305

Other routing options experience:

- LoadNG
 - IETF
 - implemented for PLC G3
 - it is a reactive Mesh Under protocol that computes the route each time a packet is being sent
- RPL
 - RFC6552, RFC6553 and RFC6554
 - implemented for ZigBeeIP
 - it is a proactive Route Over protocol defined for Low Power and Lossy networks which has a series of drawbacks like single points of failure if the DO-DAG dies





THREAD

for MKW2x

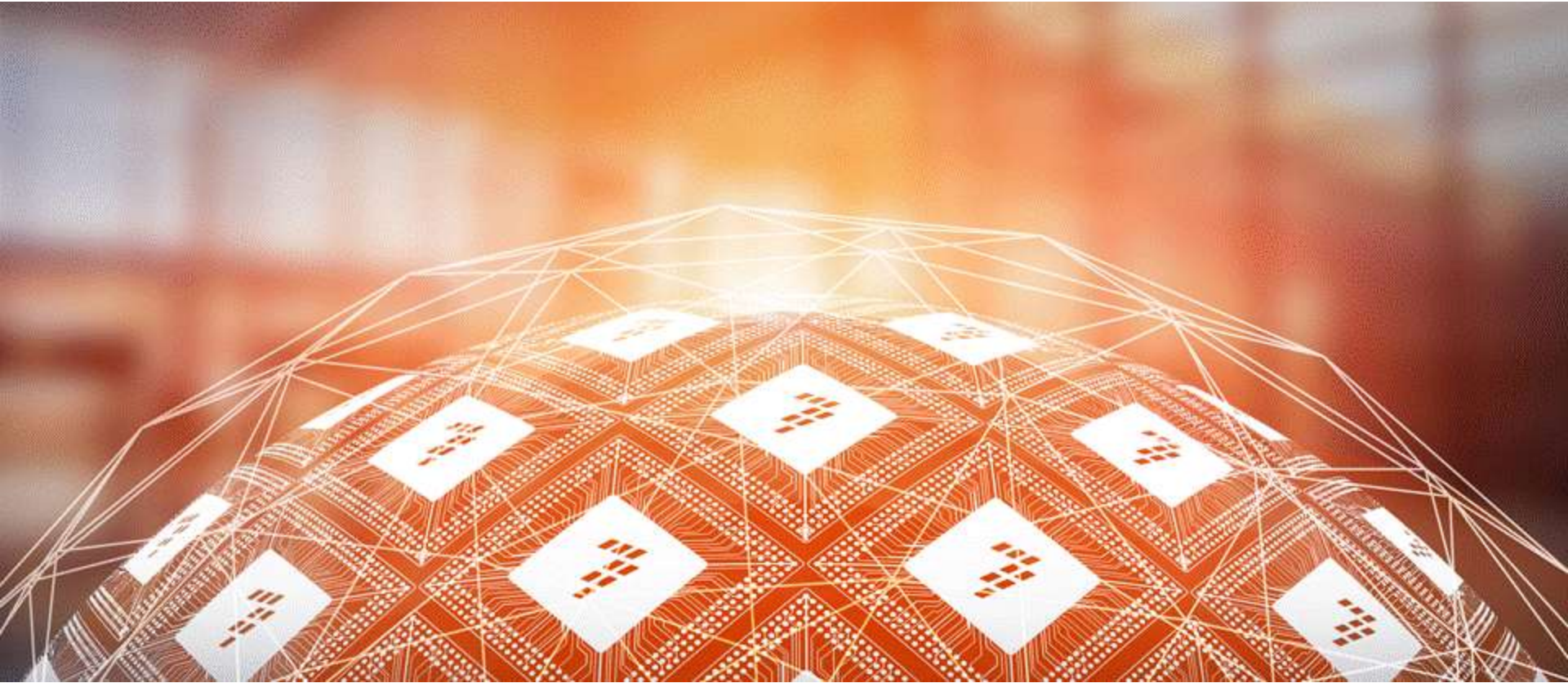



The need for a new wireless network

- We are entering a new era of connected products
 - There needs to be a low power mesh network in addition to Wi-Fi in your home
- We wanted to use an existing wireless mesh protocol
 - But none fit our requirements well enough
 - Some came close but were not suitable for homes and CE products
- After talking with other companies it was clear that they shared the same concerns
 - So we started working on a new wireless mesh protocol. One that was built on existing standards but legacy-free
 - Working as a group of companies to help make Thread better

Requirements:

New wireless home network

- ✓ Low power
- ✓ Resilient (mesh)
- ✓ IP-based
- ✓ Open protocol
- ✓ Secure and user friendly
- ✓ Fast time to market
- ✓ Existing radio silicon



THREAD

What it delivers

- A secure wireless mesh network for your home and its connected products
 - Built on well-proven, existing technologies
 - Uses 6LoWPAN and carries IPv6 natively
 - Runs on existing 802.15.4 silicon - Product development can start today
- Designed with a new security architecture to make it simple and secure to add and remove products
- Supports 250+ products per network
- Designed for very low power operation

Thread can support many popular application layer protocols

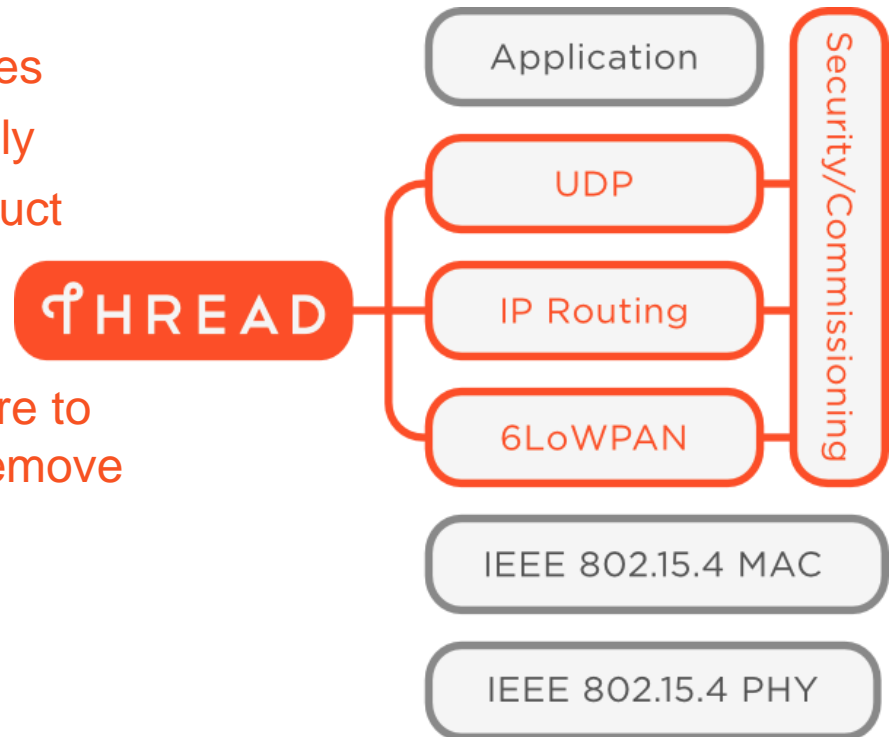

A software upgrade can add Thread to currently shipping 802.15.4 products

THREAD Freescale Involvement

- Freescale is a founding member of the Thread Group
 - We have an officer position on the Board of Directors
- Thread based Freescale solutions
 - Freescale is heavily involved in Organizational, Specification and Certification activities
 - Thread is implemented on Kinetis W (MKW2x)
 - Target is to have an implementation ready when the certification program is released 1H15
 - Alpha customer program in 4Q14
 - Please have customer register interest at www.freescale.com/thread

<https://community.freescale.com/community/wireless-connectivity>

Présentation **Contenu** Personnes Sous-espaces et projets Calendrier

Catégories - effacer la sélection

- <1GHz
- 2.4 GHz
- Bluetooth Low Energy
- IPv6 / 6LoWPAN
- Thread**
- Wireless M-Bus
- ZigBee & RF4CE

Tout le contenu (6) Documents (0) Discussions (6) Sondages (0) Événements (0) Idées (0) Vidéos (0)

Saisissez vos critères Filtrer par tag Trier par activité récente : (commencer par la plus récente) ▼

Freescale products implementing Thread wirel...

Freescale Kinetis KW platforms for 2.4GHz natively support Thread. Kinetis KW2x wireless MCUs running the Thread protocol stack integrate a wireless IEEE 802.15.4 compliant transceiver with an ARM Cortex-M microcontr...

dernière modification effectuée par [Mihai-Andrei Dragnea](#)

1 0 1

Commissioning of Thread devices

Thread uses a secure scheme of commissioning based on the proven DTLS open standard. Users can authorize devices onto a Thread network using smart phones, tablets, or laptops/PCs. Also, GUI rich devices within...

dernière modification effectuée par [Mihai-Andrei Dragnea](#)

1 0 0

Advantages of using IPv6 for Home Automation appl...

Using the Internet Protocol enables applications with connectivity needs to be portable and loosely coupled from the MAC and transport layer technologies (e.g. Thread, Wi-Fi or Ethernet). This is achieved by u...

dernière modification effectuée par [Mihai-Andrei Dragnea](#)

0 0 0

Typical device roles within a Thread network

The Thread specification defines a distributed mesh network topology based on IPv6. It provides the framework for a resilient network with no single point of failure, including self-healing and self-extending ...

dernière modification effectuée par [Mihai-Andrei Dragnea](#)

3 0 0

How Thread compares to ZigBee, Wi-Fi, or Bluetooth ?

Thread is a new, reliable and secure wireless mesh network technology based on the IEEE 802.15.4 MAC and PHY standard and Internet Protocol (IPv6). It can be deployed to IEEE 802.15.4 compliant chipsets such ...

dernière modification effectuée par [Mihai-Andrei Dragnea](#)

1 0 0

Use KW24D512 as Sniffer in Wireshark

Enabling KW2x platform to be used as sniffer with Wireshark Packet Analyzer. SREC: USB-KW24D512_802.15.4_Sniffer.srec Board: TWR-KW24D512 with USB interface (microUSB and jumper J3[2:3]) or USB-KW24D512 dongl...

dernière modification effectuée par [Juan Carlos Pacheco Serrano](#)

1 0 1

Inbox - Boîte aux lettres - Zarader Cyril-R58027 - Outlook

<https://community.freescale.com/thread/334877>



INTERNET of Things

Sense

Process

Communicate

with



freescale





www.Freescale.com